

# Product Specification

108-5238-2

## AMPLIMITE 050 SERIES II CONNECTOR TYPE A

1. Scope :

1.1 Contents

This specification covers the requirements for product performance, test methods and quality assurance provisions of counter -EMI products (Fig. 1) of the AMPLIMITE 050 Series II connector Type A (wire-to-board).

Product part No.	Descriptions	Remarks
□-174731-□	Cap Connector Kit	Wire Side (AWG #28)
□-175707-□	Cap Connector Kit	Wire Side (AWG #30)
□-174726-□	Horizontal Type Plug Header	M 2.5 Screw mount
□-175955-□	Cap Connector Kit	Wire Side (AWG #28)
□-179524-□	Horizontal Type Plug Header	M 2.5 Screw mount
□-179583-□	Horizontal Type Plug Header	Retention Leg

Fig. 1

2. Type of Products :

Connectors of this product line are designed for wire-to-board mass termination. Further, shield effect is applied for prevention of EMI.

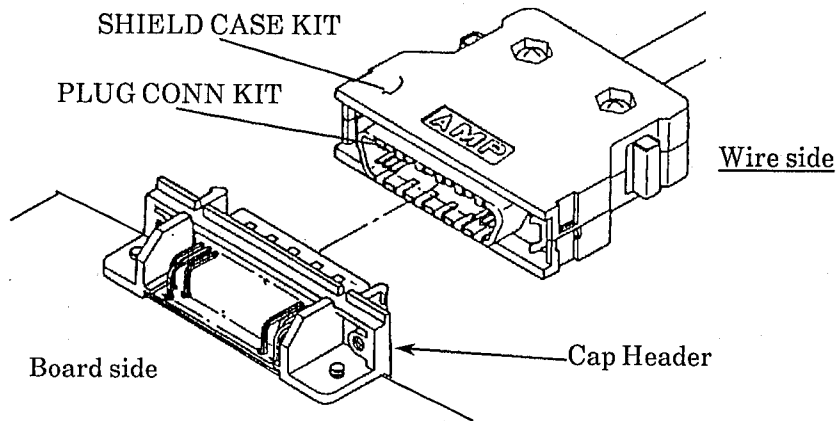

Fig. 2

					DR.	28 Jul. '88	SHEET 1 OF 9	<b>AMP</b> AMP (Japan), Ltd. Kawasaki, Japan				
					Y. Kashiwa	CHK.					28 Jul. '88	LOC
					R.Nishimura				J	A	108-5238-2	C
	C	Revised FJ00-0707-94			APP.	28 Jul. '88	NAME	<b>AMPLIMITE 050 SERIES II                  CONNECTOR TYPE A</b>				
	B	Revised RFA-1804	Y.K	R.N	6/11'91							
	LTR	REVISION RECORD	DR	CHK	DATE							

NUMBER: 108-5238-2

SECURITY CLASSIFICATION: Customer Release

PRINT DIST.

108-5238-2

NUMBER:

Customer Release

SECURITY CLASSIFICATION:

3. Product Specifications :

3.1 Product Design Feature, Construction and Dimensions

The product structure, shape and dimensions shall conform to requirements shown on applicable drawings, unless otherwise specified below.

- (1) Number of Positions ..... 20, 28, 36, 50 and 68 Positions. in 5 types
- (2) Pitch and Row ..... Engaging Side : 1.27 mm pitch × 2.54 mm in 2 rows  
Board Mount Side : 2.54 mm pitch × 1.905 mm in zigzag of 4 rows
- (3) Cap Header Type ..... Horizontal Types / Panel & Board Mount Types
- (4) Mounting on Panel & Board .. Screw Mount (M 2.5 Screws or 4-40 UNC)
- (5) Applicable Panel ..... 1.6 mm max.
- (6) Applicable Board ..... Thickness : 0.8-1.6 mm Solder-Resistance  
Treatment to be applied on soldering face.
- (7) Applicable Wire Size To be specified in Fig. 3.

Wire Size	Conductor (Tin-Plated mild copper wire)		Insulation	
	Composition	Outside Diameter	Outside Diameter	Material
AWG #28	7/0.127	0.38 mm	0.5~0.88	PVC or equivalent
AWG #30	7/0.1	0.3 mm		

Fig. 3

3.2 Material and Finish

- (1) Post Contact Material: Phosphor Bronze  
Finish : 1.3 μm min. thick nickel underplate all over, 0.2 or 0.76 μm min. thick gold-plated for contact area only, and 1.0 μm min. thick solder-plated for termination area.
- (2) Receptacle Contact Material: Phosphor Bronze  
Finish : 1.3 μm min. thick nickel underplate all over, 0.2 or 0.76 μm min. thick gold-plated for contact area only, and 1.0 μm min. thick solder-plated for tine area only.
- (3) Plug, Cap, Cover, Housing and Tine Plate  
Material: Glass – filled Thermoplastic, Polyester UL Flame Retardant  
Grade : UL 94V – 0  
Color : Black/Gray

SHEET 2 OF 9	<b>AMP</b>		AMP (Japan), Ltd. Kawasaki, Japan	
	LOC J	LOC A	NO. 108-5238-2	REV. C
NAME AMPLIMITE 050 SERIES II CONNECTOR TYPE A				

NUMBER: 108-5238-2

Customer Release

SECURITY CLASSIFICATION:

- (4) Cap Metal Shell : Material : Gold Rolled Steel Sheet  
Finish : Bright - tin Plating over Copper Underplate
- (5) Plug Metal Shell : Material : Zinc Die Cast  
Finish : Nickel-plated over Copper Underplate
- (6) Locking Spring : Material : Stainless Steel
- (7) Shield Case : Material : Molded ABS Resin, and Zinc Die Cast  
Finish : Nickel-plated over Copper Underplate

3.3 Appearance

The connectors shall be free from scratches, cracking, deformation, blister, dirt and burrs, that are detrimental to connector functions and merchandising value.

4. Product Performance :

4.1 Rating

- (1) Rated Voltage : AC 100 V
- (2) Rated Current : 1 A max.
- (3) Operating Temperature Range : -55 °C ~ +85 °C

4.2 Quality Assurance Provisions

4.2.1 Test Environments

The performance test shall be made on the environmental conditions listed below, unless otherwise specified.

- Temperature : 15~35 °C
- Relative Humidity : 45~75 %
- Atmospheric Pressure : 650~800 mmHg

4.2.2 Test Samples

- (1) The product samples to be used at the performance test shall conform to applicable product drawings.
- (2) Wires to be used for termination shall conform to those specified in Para. 3.1 (7) and applicable tools shall be used for termination.
- (3) No test sample shall be reused in the test, unless otherwise specified.
- (4) Shield case is excluded from the testing items.

SHEET 3 OF 9	<b>AMP</b>		AMP (Japan), Ltd. Kawasaki, Japan	
	LOC J	LOC A	NO. 108-5238-2	REV. B
NAME AMPLIMITE 050 SERIES II CONNECTOR TYPE A				

D

108-5238-2

NUMBER:

Customer Release

SECURITY CLASSIFICATION:

4.3 Electrical Performance

Para.	Test Items	Requirements	Procedures	
Electrical Requirements				
4.3.1	Termination Resistance (Low Level)	Initial: 20 mΩ max. After test: 30 mΩ max.	To be measured by using open circuit voltage of 50 mV max. with closed circuit current of 50 mA max. flowing through the test circuit shown in Fig. 6.	
4.3.2	Insulation Resistance	<del>1000 MΩ</del> Initial: 1000 MΩ Min. Final: 500 MΩ Min.	Engage connectors, and measure resistance between adjacent connectors per Condition B (500 V ± 10 %), Test Method 302 of MIL-STD-202.	
4.3.3	Dielectric Strength	No abnormalities such as insulation break-down or flashover shall take place during the test.	Engage connectors, and apply AC 500 V (RMS) between the adjacent contacts for 1 min. per Test Method 301 of MIL-STD-202.	
4.3.4	Temperature Rising	30 °C max.	After all the contacts series-wired, mate connectors, and measure temperature rising at the points shown in Fig. 6 by thermocouple method. Use test current of 1 A and from the measured value, deduct the room	
4.4.1	Connector Insertion / Extrsrction Force	# of Pos.	Attach plug and cap assemblies properly to tensile tester, insert and extract at the rate of speed of 100 mm /min., and read the insertion and extraction forces required. * The value regarding grounding indents is to be separately specified.	
		20		2.0 kg max. 0.5 kg min.
		28		3.0 kg max. 0.6 kg min.
		36		5.0 kg max. 0.8 kg min.
		50		6.0 kg max. 1.0 kg min.
68	7.5 kg max. 1.5 kg min.			

Fig. 4 (To be continued)

要変更

添付(次頁に挿入)

参照願います

SHEET	<b>AMP</b>			AMP (Japan), Ltd. Kawasaki, Japan
	4 OF 9	LOC J	LOC A	NO. 108-5238-2
NAME		AMPLIMITE 050 SERIES II CONNECTOR TYPE A		
				REV. B

NUMBER: 108-5238-2  SECURITY CLASSIFICATION: Customer Release	Para.	Test Items	Requirements	Procedures
	4.4.2	Durability (Repeated Mate/Unmating)	(Appearance) No physical problem tolerated. (Low-level Termination Resistance) To meet 4.3.1. (Insertion/Extraction Force) To meet 4.4.1.	Repeat insertion and extraction for 500 cycles in the same manner as specified in Para. 4.4.1.
	4.4.3	Vibration Sinusoidal High Frequency	No electrical discontinuity greater than 1 microsecond shall take place during the test. (Low-level Termination Resistance) To meet 4.3.1 (Appearance) No physical problem tolerated.	Engage the connectors with all the contacts series-wired, apply test vibration changing to reciprocate 10-500-10 Hz one cycle every 15 min. to the connector fixed on the jig. Maximum amplitude shall be 1.52 mm both sides, 10 G at the peak, as specified in Test Condition A, Test Method 204 of MIL-STD-202. Vibration shall be applied to three axial directions 3 hours each, totally 9 hours.
4.4.4	Physical Shock	No electrical discontinuity greater than 1 microsecond shall take place during the test. (Low-level Termination Resistance) To meet 4.3.1. (Appearance) No physical problem tolerated.	Engage the connectors with all the contacts series-wired, and applying test current of 100 mA to the circuit, test in accordance with Test Condition C, Test Method 213 of MIL-STD-202. The vibration shall be : Standard holding time : 6 msec. Max. value : 100 g's Waveform : Semi-sine waveform Directions and Number of Cycles : 3 Drops each in X, Y and Z (total 18 times)	

Fig. 4 (To be continued)

SHEET 5 OF 9	<b>AMP</b>			AMP (Japan), Ltd. Kawasaki, Japan
	LOC J	LOC A	NO. 108-5238-2	REV. C
NAME AMPLIMITE 050 SERIES II CONNECTOR TYPE A				

NUMBER: 108-5238-2

SECURITY CLASSIFICATION: Customer Release

Para.	Test Items	Requirements	Procedures															
4.4.5	Resistance to Soldering Heat	To be free from such physical problems as play in contact, cracking and deformation of housing.	Mount connector on the board, and dip in a molten solder bath so that the underside of the board is held in the bath. Molten solder Temperature : 260 ± 5 °C Dipping time : 3 sec.															
<b>Environmental Requirements</b>																		
4.5.1	Humidity-Temperature Cycling	(Insulation Resistance) 500 M min. (Dielectric Strength) To meet 4.3.3. (Low-level Termination Resistance) To meet 4.3.1.	Engage connectors, and test per Test Method 106 D of MIL-STD-202. Test cycle (24 hrs.) : 25 °C → 65 °C → 25 °C → 65 °C → 25 °C under relative humidity of 80~98%. Repeat this test cycle 10 times.															
4.5.2	Thermal Shock	(Low-level Termination Resistance) To meet 4.3.1. (Appearance) No physical problem tolerated.	Engage connectors, and test 5 cycles on end per Condition A (see table below), Test Method 107 D of MIL-STD-202.															
			<table border="1"> <thead> <tr> <th>Step</th> <th>Temp. (°C)</th> <th>Time (min.)</th> </tr> </thead> <tbody> <tr> <td>1</td> <td>-55 <sup>+0</sup>/<sub>-3</sub></td> <td>30</td> </tr> <tr> <td>2</td> <td>25 <sup>+10</sup>/<sub>-5</sub></td> <td>5 Max.</td> </tr> <tr> <td>3</td> <td>85 <sup>+3</sup>/<sub>-0</sub></td> <td>30</td> </tr> <tr> <td>4</td> <td>25 <sup>+10</sup>/<sub>-5</sub></td> <td>5 Max.</td> </tr> </tbody> </table>	Step	Temp. (°C)	Time (min.)	1	-55 <sup>+0</sup> / <sub>-3</sub>	30	2	25 <sup>+10</sup> / <sub>-5</sub>	5 Max.	3	85 <sup>+3</sup> / <sub>-0</sub>	30	4	25 <sup>+10</sup> / <sub>-5</sub>	5 Max.
			Step	Temp. (°C)	Time (min.)													
			1	-55 <sup>+0</sup> / <sub>-3</sub>	30													
			2	25 <sup>+10</sup> / <sub>-5</sub>	5 Max.													
3	85 <sup>+3</sup> / <sub>-0</sub>	30																
4	25 <sup>+10</sup> / <sub>-5</sub>	5 Max.																
4.5.3	Temperature Life	(Low-level Termination Resistance) To meet 4.3.1. (Appearance) No physical problem tolerated.	Engage connectors, and test for 250 hrs. at 85 ± 2 °C (Condition B) per Test Method 108A of MIL-STD-202.															

Fig. 4 (to be continued)

SHEET 6 OF 9	<b>AMP</b>		AMP (Japan), Ltd. Kawasaki, Japan	
	LOC J	LOC A	NO. 108-5238-2	REV. C
NAME AMPLIMITE 050 SERIES II CONNECTOR TYPE A				

NUMBER: 08 5238-2

SECURITY CLASSIFICATION:

Customer Release

Para.	Test Items	Requirements	Procedures
4.5.4	SO <sub>2</sub> (APPLIED 0.76 $\mu$ m GOLD PL. PRODUCTS)	(Low-level Termination Resistance) To meet 4.3.1	Engage connecrors, and expose to SO <sub>2</sub> on folloing conditions. SO <sub>2</sub> concentration : 10 $\pm$ 3 ppm Relative humidity : 90 % min. Temperature : Room temperature Time : 48 hours

Fig. 4 (end)

SHEET 7 OF 9	<b>AMP</b> AMP (Japan), Ltd. Kawasaki, Japan			REV. C
	LOC J	LOC A	NO. 108-5238-2	
NAME AMPLIMITE 050 SERIES II CONNECTOR TYPE A				

NUMBER: 108-5238-1

Customer  
ReleaseSECURITY  
CLASSIFICATION:

## 5. Test Sequence :

All the tests shall be performed in accordance with the test sequence specified below.

Test Item	Item No.	Test Group								
		1	2	3	4	5	6	7	8	9
Appearance	3.3	1	1	1	1	1	1	1	1	1
Low-level Termination Resistance (Initial)	4.3.1	3	2	2	2	2	2			
Insulation Resistance (Initial)	4.3.2							2		
Dielectric Strength (Initial)	4.3.3							3		
Temperature Rising	4.3.4								2	
Connector Insertion / Extraction Force	4.4.1	2								
Durability	4.4.2	4								
High Frequency Vibration	4.4.3						3			
Physical Shock	4.4.4						4			
Soldering Heat Resistivity	4.4.5									2
Humidity Resistance	4.5.1		3					4		
Thermal Shock	4.5.2			3						
Heat Aging	4.5.3				3					
SO <sub>2</sub>	4.5.4					3				
Low-level Termination Resistance (Final)	4.3.1	6	4	4	4	4	5			
Insulation Resistance (Final)	4.3.2							5		
Dielectric Strength (Final)	4.3.3							6		
Connector Insertion / Extraction Force (End)	4.4.1	5								
Appearance (End)	3.3		5	5	5		6	7	3	3
No. of Test Samples		5	3	3	3	3	3	3	1	1

(Note) 1. To be tested in groups in sequence indicated by encircled figure.

Fig. 5

SHEET 8 OF 9	<b>AMP</b>		AMP (Japan), Ltd. Kawasaki, Japan	
	LOC J	LOC A	NO. 108-5238-2	REV. C
NAME AMPLIMITE 050 SERIES II CONNECTOR TYPE A				



NUMBER: 108-5238-1

SECURITY CLASSIFICATION: Customer Release

[Measurement of Low-level Resistance]

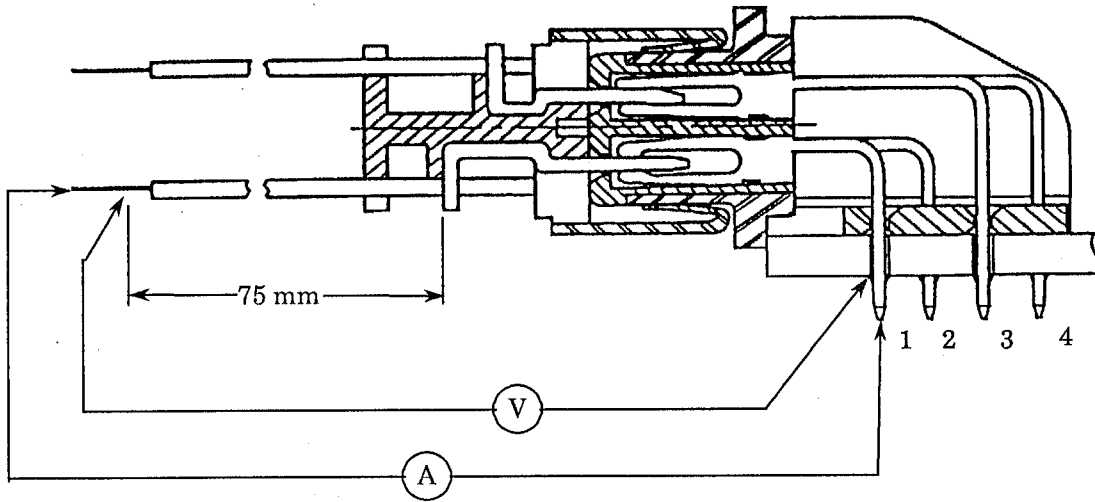

Low-level Resistance = Measured Reading - Wire Resistance (75 mm)

Fig. 6

SHEET 9 OF 9	<b>AMP</b>		AMP (Japan), Ltd. Kawasaki, Japan	
	LOC J	LOC A	NO. 108-5238-2	REV. C
NAME AMPLIMITE 050 SERIES II CONNECTOR TYPE A				