

PRODUCT SPECIFICATION

108-5616

AMP Mini CT HYBRID LATTICE CONNECTOR (1.5mm PITCH)

1. Scope :

1.1 Contents

This specification covers the requirements for product performance, test methods and quality assurance provisions of AMP Mini CT Hybrid Lattice Connector. Applicable product description and part numbers are as shown in Fig.1.

2. Applicable Documents:

The following documents form a part of this specification to the extent specified herein. In the event of conflict between the requirements of this specification and the product drawing, the product drawing shall take precedence. In the event of conflict between the requirements of this specification and the referenced documents, this specification shall take precedence.

2.1 AMP Specifications :

- A. 109-5000 Test Specification, General Requirements for Test Methods
- B. 114-5256 Application Specification
- C. 501-51022 Qualification Test Report

2.2 Commercial Standards and specifications :

- A. MIL-STD-202 : Test Methods for Electronic and Electrical Component Parts.
- B. IEC : International Electrotechnical Commission

3. Requirements :

3.1 Design and Construction :

Product shall be of the design, construction and physical dimensions specified on the applicable product drawing.

THIS DOCUMENT IS THE PROPERTY OF AMP MANUFACTURING (SINGAPORE) PTE LTD. IT IS TO BE USED ONLY FOR THE PURPOSES SPECIFIED IN THE DRAWING. NO PART OF THIS DOCUMENT IS TO BE REPRODUCED OR TRANSMITTED IN ANY FORM OR BY ANY MEANS, ELECTRONIC OR MECHANICAL, INCLUDING PHOTOCOPYING, RECORDING, OR BY ANY INFORMATION STORAGE AND RETRIEVAL SYSTEM, WITHOUT THE WRITTEN AUTHORIZATION FROM AMP MANUFACTURING (SINGAPORE) PTE LTD.

				DR	WL CHOO	 AMP MANUFACTURING (SINGAPORE) PTE LTD 26 ANG MO KIO INDUSTRIAL PARK 2 SINGAPORE 2056 TEL : 4820311 (20 LINES) FAX NO. 65-4821012		
				CHK	J. TANIGAWA			
				APP	SEE LAST PAGE		NO	
B	Revised FP00-0371-01	WJ	14/09/01			108-5616	REV B	LOC DY
A	Revised FP00-0104-00	CWL	30/06/00	PAGE	TITLE	AMP Mini CT Hybrid Lattice Connector (1.5mm Pitch)		
O	Released FJ00-2334-98	S.K.	18/12/99	1 OF 14				
LTR	REVISION RECORD	APP	DATE					

3.2 Materials :

3.2.1 Plug Assembly

A. Signal Contact

Material: Phosphor Bronze

Finish (Mini CT post area):

1µm min. Tin-lead over 2-5µm Nickel underplate.

Finish (Drawer mating area):

i) 0.5µm min. Gold over 2-5µm Nickel underplate, or

ii) 0.05µm min. Gold over 0.5µm Palladium-Nickel over 2-5µm Nickel underplate.

B. Power Contact

Material: Phosphor Bronze

Finish: Pre-plated Tin 0.8µm min.

C. Housing

Material: Nylon 6/6, UL94V-0

3.2.2 Receptacle Assembly

A. Signal Contact

Material: Brass

Finish (Mini CT post area):

1µm min. Tin-lead over 2-5µm Nickel underplate.

Finish (Drawer mating area):

i) 0.5µm min. Gold over 2-5µm Nickel underplate, or

ii) 0.05µm min. Gold over 0.5µm Palladium-Nickel over 2-5µm Nickel underplate.

B. Power Contact

Material: Phosphor Bronze

Finish: Pre-plated Tin 0.8µm min.

C. Housing

Material: Glass-filled PBT, UL94V-0

3.2.3 Accessories & Hardware

A. Dust Cover: Nylon 6/6, UL94V-0

B. Cable Clamp: Cold Rolled Steel, Zinc plated

C. Plug Covers: ABS/PC Polymer Alloy, UL94-HB

D. Screws: Steel, Zinc plated



AMP MANUFACTURING SINGAPORE PTE LTD
No. 26, Ang Mo Kio Industrial Park 2,
Singapore 2056

Page

2

NO

108-5616

REV

B

LOC

DY

3.3 Ratings :

A. Voltage Rating (Signal): 50 VAC/DC

Voltage Rating (Power): 250 VAC

B. Current Rating(Signal): 1A Max.

Current Rating(Power):

AWG #16 : 7A

AWG #18 : 6A

AWG #20 : 5A

C. Temperature Rating : -30°C to +105°C

The upper limit of temperature rating includes the temperature rise resulted from energized electrical current.

3.4 Performance Requirements and Test Descriptions :

The product shall be designed to meet the electrical, mechanical and environmental performance requirements specified in Fig. 2.

All tests shall be performed in the room temperature, unless otherwise specified.

Product Part No.	Description
x-1123915-x x-1318657-x	Plug Assembly Kit, 1.5mm Pitch Mini CT Hybrid Lattice Connector.
x-1123912-x	Plug Assembly, 1.5mm Pitch Mini CT Hybrid Lattice Connector.
x-1318188-x	Receptacle Assembly Kit, 1.5mm Pitch Mini CT Hybrid Lattice Connector.
x-1123909-x	Receptacle Assembly, 1.5mm Pitch Mini CT Hybrid Lattice Connector.
1123907-1	Power Receptacle Contact, Hybrid Lattice Connector.
1123910-1	Power Tab Contact Hybrid Lattice Connector.
x-1123913-x x-1123914-x x-1318655-x x-1318656-x	Plug Covers, 1.5mm Pitch Mini CT Hybrid Lattice Connector.
x-1123919-x x-1318452-x	Dust Cover, 1.5mm Pitch Mini CT Hybrid Lattice Connector.

Fig. 1

	AMP MANUFACTURING SINGAPORE PTE LTD No. 26, Ang Mo Kio Industrial Park 2, Singapore 2056	Page	NO	REV	LOC
		3	108-5616	B	DY

3.5 Test Requirements and Procedures Summary:

Para.	Test Items	Requirements	Procedures
3.5.1	Examination of Product	Meets requirements of product drawing.	Visual inspection No physical damage
Electrical Requirements			
3.5.2	Termination Resistance (Low Level)	Signal Line: 30mΩ Max. (Initial) 40mΩ Max. (Final) Power Line: 10mΩ Max. (Initial) 20mΩ Max. (Final)	Subject mated connectors to 20 mV Max open circuit at 10 mA Refer Fig.4.
3.5.3	Dielectric withstanding Voltage	No creeping discharge nor flashover shall occur. Current leakage : 5mA Max.	Signal Line: 500 VAC for 1 minute. Power Line: 2.2 kVAC for 1 minute. Test between adjacent circuits of mated connectors. MIL STD 202 TEST METHOD 301 IEC 512-2 TEST 4A
3.5.4	Insulation Resistance	500 MΩ Min. (Initial) 100 MΩ Min. (Final)	Apply voltage 500 VDC for 1 minute. Test between adjacent circuits of mated connectors. MIL STD 202 TEST METHOD 302 CONDITION B
3.5.5	Temperature Rise	30 °C Max. under loaded rating current.	Contacts series-wired, apply rated current to the circuit, and measure the temperature rise, after the temperature becomes stabilized. Deduct ambient temperature from the measured value.

Fig.2 (To be continued)

Para.	Test Items	Requirements			Procedures	
Mechanical Requirements						
3.5.6	Crimp Tensile Strength (Power contacts only)	Wire Size		Crimp Tensile (Min)		Apply an axial pull-of load to a crimped wire, with the contact secured to the tester. Operation Speed: 100 mm/min.
		mm ²	AWG	N	Kgf	
		0.51	#20	58.8	6	
		0.87	#18	68.6	7	
		1.27	#16	78.4	8	
3.5.7	Contact-housing Insertion Force (Power contacts only)	9.8 N(1.0 kgf) Max. per contact.			Measure force required to insert contact into housing.	
3.5.8	Contact Mating / Unmating Force (Power Receptacle contacts only)	Mating Force (Max.)		Unmating Force (Min.)		Measure using gage tab (Fig. 6) with operational speed of 100mm/min.
		6.86N (0.7kgf) (Initial ~ 25 th cycles)		0.34N(35gf) (Initial) 0.25N(25gf) (25 th cycles)		
3.5.9	Contact Retention Force	Signal Contact: 14.7 N(1.5 kgf) Min., in direction of mating with Mini CT Receptacle. Power Contact: 41.2N (4.2 kgf) Min.			Measure contact retention force. Operation Speed : 100 mm/min.	
3.5.10	Connector Mating / Unmating Force	Pos. size (Power/ Signal)	Mating Force (Max.)	Unmating Force (Min.)		Operation Speed : 100 mm/min. Measure the force required to mate and unmate connectors. Housing lock is not to be included.
		4/14	41.2N (4.2kgf)	7.2N (0.74kgf)		
		4/22	49N (5.0kgf)	8N (0.82kgf)		

Fig.2 (To be continued)

Para.	Test Items	Requirements	Procedures
3.5.11	Panel Retention Force	156.8 N (16 kgf) Min.	Measure panel retention force using panel of nominal cut-out dimensions as specified in the AMP Customer Drawing. Loading is made from the direction opposite to connector insertion direction.
3.5.12	Housing Lock Strength	98N (10kgf) Min.	Measure connector locking strength. Operational speed: 100mm/min.
3.5.13	Safety Test - exposure of contacts to test finger. (Receptacle Assembly only)	No electrical conductivity between test finger and contacts in housing.	Insert test finger (dimensions per Fig. 19 of IEC-950) into Receptacle Assembly. Check for electrical conductivity between test finger and contacts.
3.5.14	Cable Retention Force (Axial Direction)	98N (10kgf) Min.	Measure cable retention force in axial direction. Operational speed: 100mm/min.
3.5.15	Durability (Repeated Mating & Unmating)	Signal Line: 40mMax. (Final) Power Line: 20mMax. (Final)	Operation Speed : 100 mm/min. No. of Cycles : 25 cycles.

Fig.2 (To be continued)

Para.	Test Items	Requirements	Procedures
3.5.16	Vibration (Low Frequency)	No electrical discontinuity greater than 1μsec. Shall occur. Signal Line: 40mMax. (Final) Power Line: 20mMax. (Final)	Subject mated connectors to 10-55-10 Hz traversed in 1 minute at 1.52 mm amplitude 2 hours each of 3 mutually perpendicular planes. MIL-STD-202 TEST METHOD 201 CONDITION A Mounting : Fig. 5
3.5.17	Physical Shock	No electrical discontinuity greater than 1μsec. Shall occur. Signal Line: 40mMax. (Final) Power Line: 20mMax. (Final)	Accelerated Velocity: 490 m/s ² (50G) Waveform: halfsine shock pulse Duration: 11 msec. Number of shocks: 3 shocks in each direction applied along the X, Y and Z axes, totally 18 shocks. MIL-STD-202 TEST METHOD 213 CONDITION A IEC 68-2-27, Test Ea Mounting : Fig. 5
3.5.18	Hammering Shock	No electrical discontinuity greater than 1μsec. Shall occur. Signal Line: 40 mΩ Max. (Final) Power Line: 20 mΩ Max. (Final)	Subject mated connectors to 10,000 cycles of hammering shocks in set-up as shown in Fig. 7, with test current of 1mA at DC 10V applied to circuits as shown in Fig. 8. During the test, the circuit shall be monitored for fluctuation of electrical resistance.

Para.	Test Items	Requirements	Procedures
Environmental Requirements			
3.5.19	Thermal Shock	Signal Line: 40 mΩ Max. (Final) Power Line: 20 mΩ Max. (Final)	Subject mated connectors to -55°C / 30 min., +85°C/ 30 min. This being 1 cycle, repeat for a total of 25 cycles. MIL-STD-202 TEST METHOD 107
3.5.20	Humidity-Temperature Cycling	Insulation resistance 100 MΩ Min.(Final) Termination resistance Signal Line: 40 mΩ Max. (Final) Power Line: 20 mΩ Max. (Final)	Subject mated connectors to 25~65°C, 90~95% R.H., 10 cycles. With cold shock -10°C. Re-condition in room temperature for 3Hrs before subsequent measurements. MIL-STD-202 TEST METHOD 106 IEC 68-2-38, Test Db.
3.5.21	Salt Spray	Signal Line: 40 mΩ Max. (Final) Power Line: 20 mΩ Max. (Final)	Subject mated connectors to 5 ± 1% salt concentration for 48 hours. After test, rinse samples with water and recondition to room temperature for 1 hour before subsequent measurements. MIL-STD-202 TEST METHOD 101, CONDITION B. IEC 68-2-11, Test Ka.

Fig.2 (To be continued)

AMP	AMP MANUFACTURING SINGAPORE PTE LTD No. 26, Ang Mo Kio Industrial Park 2, Singapore 2056	Page	NO	REV	LOC
		8	108-5616	B	DY

Para.	Test Items	Requirements	Procedures
3.5.22	Temperature Life (Heat Aging)	Signal Line: 40 mΩ Max. (Final) Power Line: 20 mΩ Max. (Final)	Subject mated connectors to 85± 2°C, 500 hours. MIL-STD-202 TEST METHOD 108.

Fig.2 (End)

4. Product Qualification Test Sequence

Test Item	/Test Group																	
	1	2	3	4	5	6	7	8	9	10	11	12	13	14	15	16	17	
	/Test Sequence (a)																	
Examination of Product	1,4,8	1,3	1,3	1,3	1,3	1,3	1,3	1,3	1,3	1,3	1,3	1,6	1,5	1,5	1,5	1,5	1,5	1,5
Termination Resistance (Low Level)	2,5											2,5	2,4	2,4	2,4	2,4	2,4	2,4
Dielectric withstanding Voltage	7																	
Insulation Resistance	6																	
Temperature Rise		2																
Crimp Tensile Strength			2															
Contact-housing Insertion Force				2														
Contact Mating/Unmating Force					2													
Contact Retention Force						2												
Connector Mating/Unmating Force							2											
Panel Retention Force								2										
Housing Lock Strength									2									
Safety Test - Test Finger											3							
Cable Retention Force										2								
Durability (Repeated Mating/Unmating)											4							
Vibration (Low Frequency)												3						
Physical Shock													3					
Hammering Shock														3				
Thermal Shock															3			
Humidity-Temperature Cycling	3																	
Salt Spray																	3	
Temperature Life (Heat Aging)																		3

(a) /Numbers indicate sequence in which the tests are performed.

Fig.3

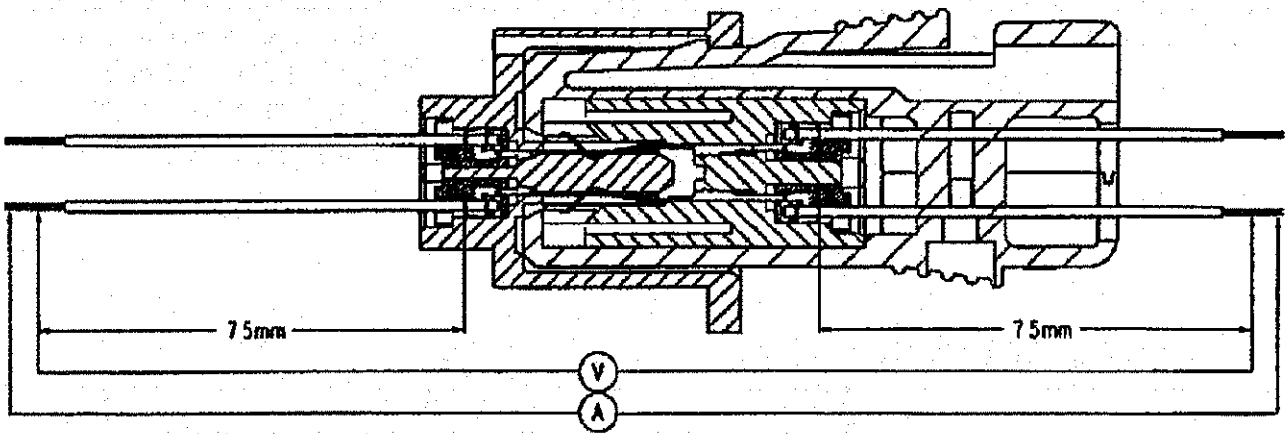

Fig. 4a:
(Signal Line Termination Resistance Measurement Method)

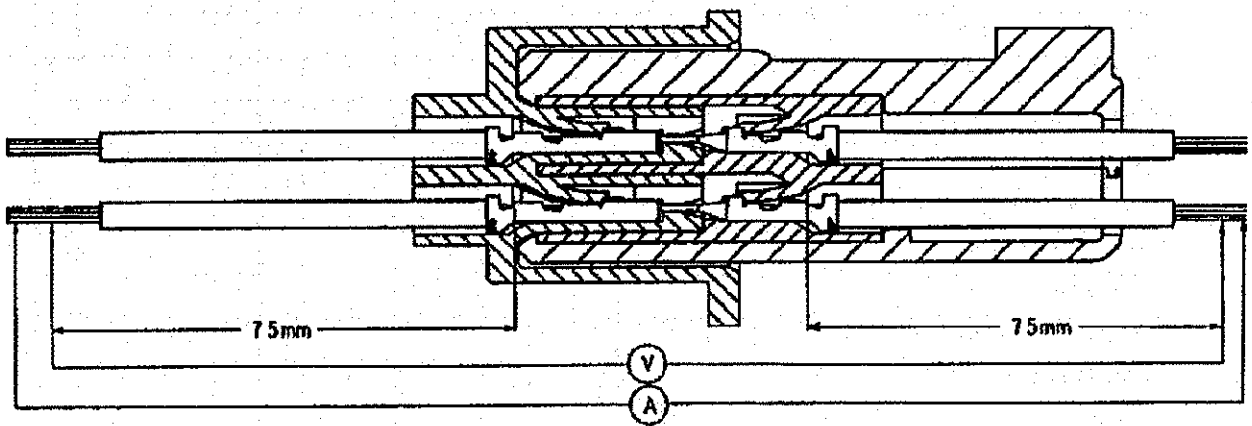

Fig 4b:
(Power Line Termination Resistance Measurement Method)

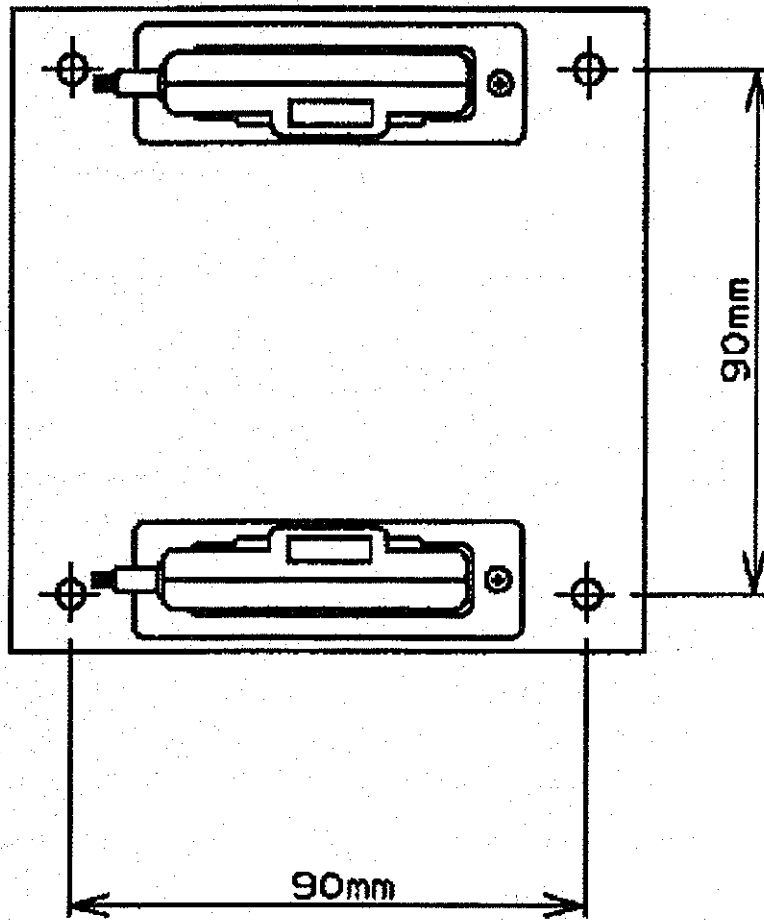

Fig. 5: Vibration Test Mounting

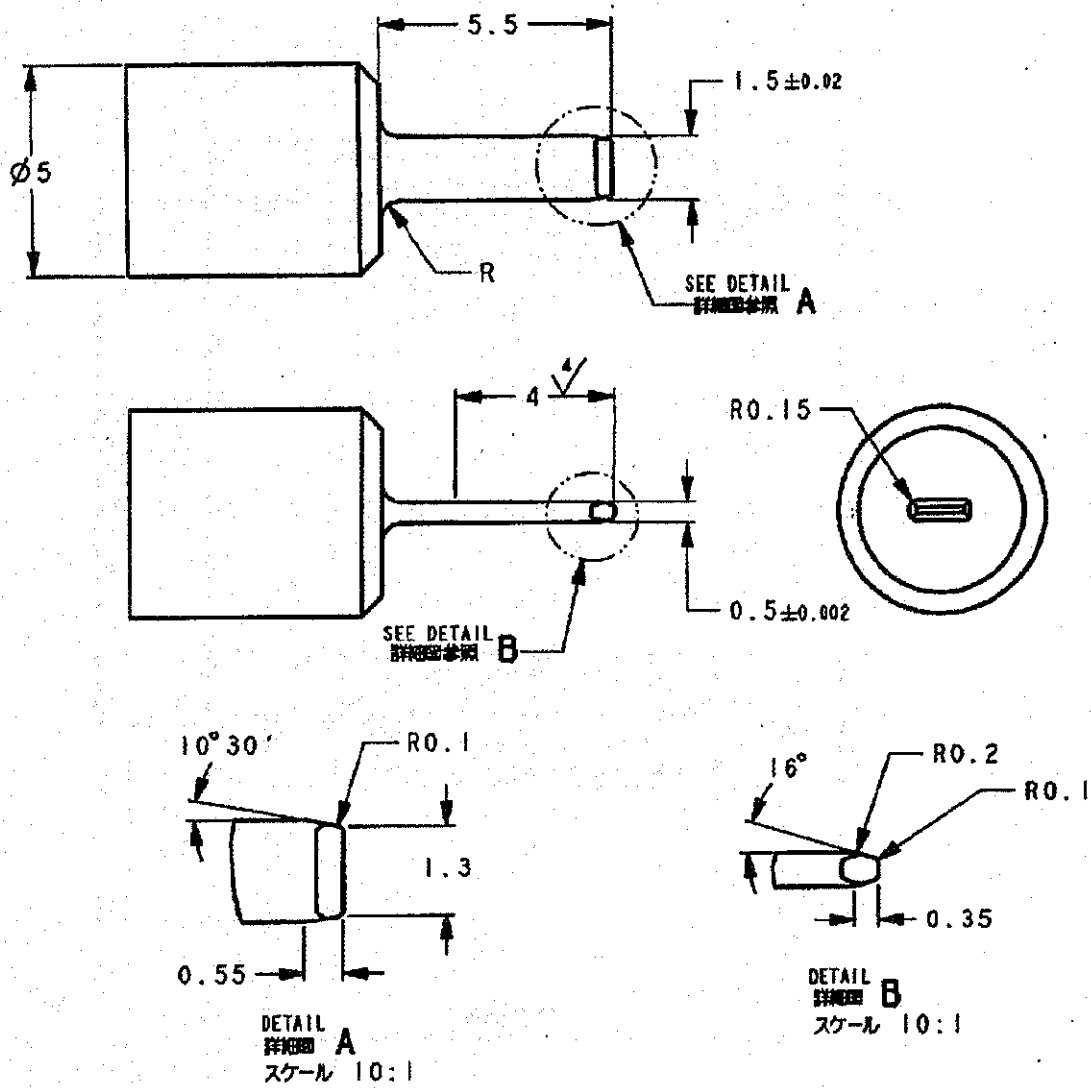

Fig. 6: Contact Mating/Unmating Force Gage

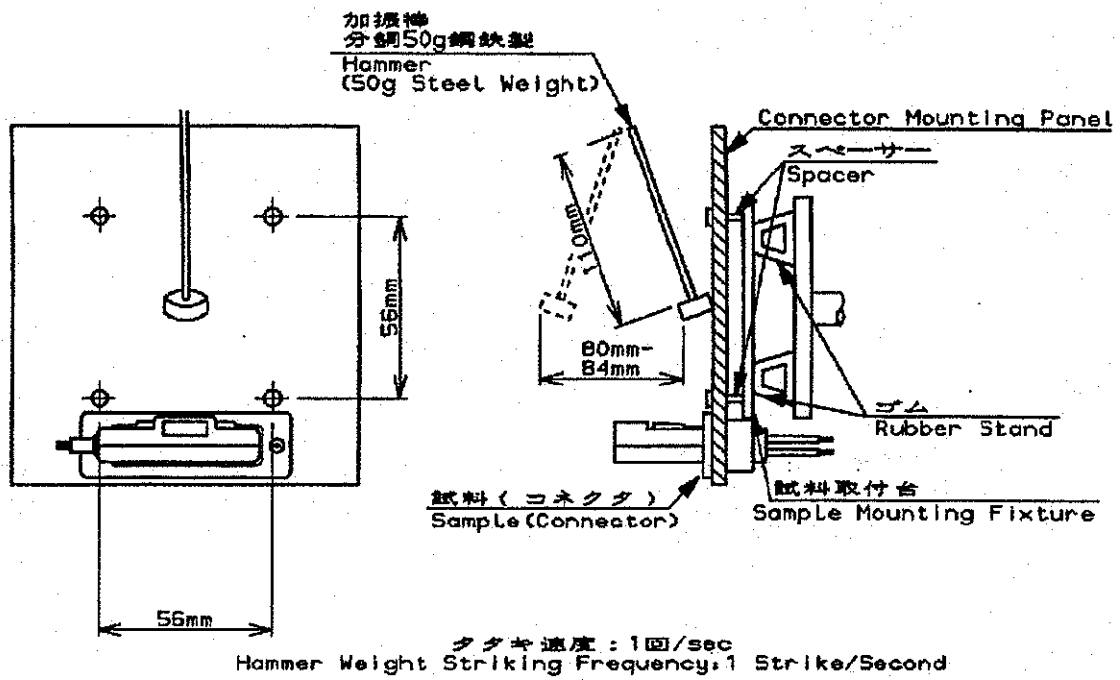

Fig. 7: Hammering Shock Test

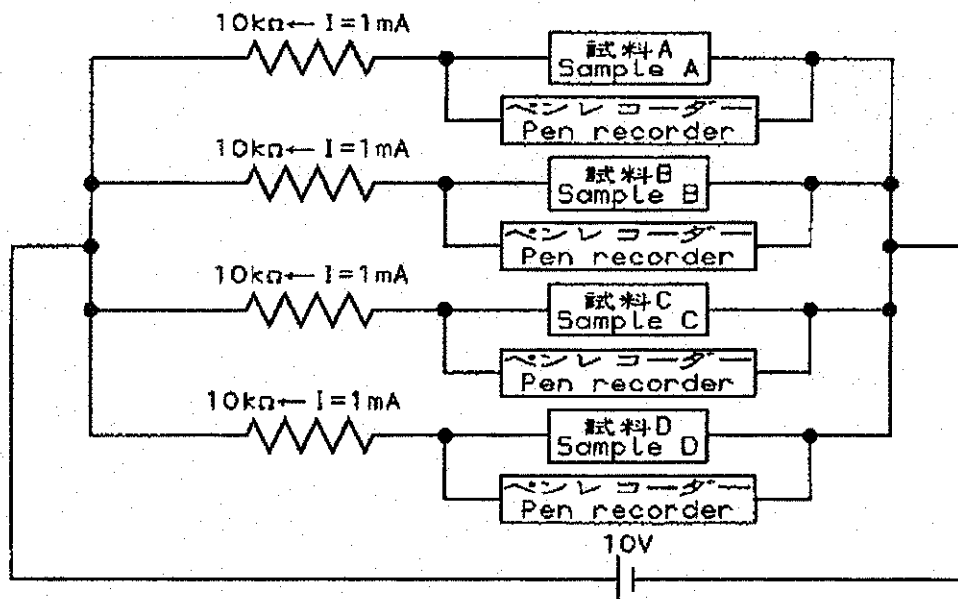

Fig. 8: Electrical Resistance Fluctuation Monitoring Circuit

5.

VALIDATIONS

Prepared by:

L. TAN

17 SEP '01

Tan Lay Peng
Product Engineer
Product Engineering
Tyco Electronics Singapore Pte. Ltd.

Reviwed by:

W. L. CHOO

26 SEP '01

Choo Wing Lian
Product Engineering Manager
Product Engineering
Tyco Electronics Singapore Pte. Ltd.

Approved by:

S F LEONG 20 SEP '01

Leong See Fan
Product Engineering Division Manager
Product Engineering
Tyco Electronics Singapore Pte. Ltd