

MODULAR JACK, RJ45, SIDE ENTRY, LOW PROFILE.

1. SCOPE

This specification covers performance, tests and quality requirements for **MODULAR JACK, RJ45, SIDE ENTRY, LOW PROFILE.**

2. APPLICABLE DOCUMENT

The following documents form a part of this specification to the extent specified herein. In the event of conflict between the requirements of this specification and the product drawing, the product drawing shall take precedence. In the event of conflict between the requirements of this specification and the referenced documents, this specification shall take precedence.

Test Report : 501-57268 REV.O

3. REQUIREMENTS

3.1. DESIGN AND CONSTRUCTION

Product shall be of the design, construction and physical dimensions specified on the applicable product drawing.

3.2. MATERIALS

A. Housing: Thermoplastic High Temperature, UL94V-0.

Contact: Copper Alloy, Gold plating on contact area,
Nickel underplated all over.

3.3. RATINGS

A. Current Rating: 1 A Max.

B. Voltage Rating: 150 VAC Max.

C. Operating temperature: -40°C to +70°C.

3.4. TEST CONDITION

The product is designed to meet the electrical, mechanical and environmental performance requirements specified in Figure 1.

DR	DATE	CHK	DATE	APVD	DATE
Oblic Hu	30-Aug-2002	Jerry Cheng	30-Aug-2002	Jebb Wu	30-Aug-2002
					FZ00-0192-02

3.5. TEST REQUIREMENTS AND PROCEDURES SUMMARY

TEST DESCRIPTION	REQUIREMENTS	PROCEDURES
Examination of product.	Meets requirements of product drawing and AMP Specification.	Visual inspection No physical damage.
ELECTRICAL		
Contact Resistance.	35 mΩ max.	EIA-364-23A See Figure 1.
Insulation Resistance.	1000 MΩ Min.	EIA-364-20A 100 VDC Adjacent circuits of mated connectors.
Dielectric Withstanding Resistance.	No creeping discharge or flashes occur.	EIA-364-09B 1000 VAC rms. , For 1 minute applied between Adjacent contacts. 1500 VAC rms. , For 1 minute applied between Shield and contacts.
MECHANICAL		
Durability.	See Note (a)	EIA-364-09B Operation speed : 10~20 cycles /min. Operation cycles : 750 cycles.
Mating Force.	2.0 Kgf max.	EIA-364-13A The test speed should be 12.5mm per minute.
Connector Normal Force	100 gf min.	Subject gage (φ0.56mm diameter pin) shifted from h2 vertical to the h1 horizontal position, as Figure 2. MIL-STD-1344A, Method 2014
ENVIRONMENTAL		
Humidity Test.	Δ R = 10 mΩ max. Final.	MIL-STD-1344A, Method 1002.2 At a temperature of 40°C± 2°C and relative humidity of 90~ 95% for 96 hours.
Salt Spray.	Δ R = 10 mΩ max. Final.	EIA-364-26A, Condition A. 5% for 24 hours.
Temperature Life.	Δ R = 10 mΩ max. Final.	MIL-STD-1344A, Method 1005.1 Temperature 85°C for 250 hours.
PHYSICAL		
Solderability.	The test area shall be covered more than 95% of immersed area with fresh solder.	MIL-STD-202F, Method 208C. Test temperature : 245± 5°C. Dip tails into flux for 5 second, drain, and then dip into the solder pot and keep for 5 seconds.
Resistance to Soldering heat.	See Note(a)	MIL-STD-202F, Method 208C. 260± 10°C, 5± 1 sec. The terminal of jack tested shall be heated to 2mm from a tip of the terminal by a soldering iron.

Figure 1

3.6. PRODUCT QUALIFICATION AND REQUALIFICATION TEST SEQUENCE

Test or Examination	Test Group					
	A	B	C	D	E	F
	Test Sequence (a)					
Examination of Product	1,8	1,7	4	4	3	
Contact Resistance	3,5,7		1,3	1,3		
Insulation Resistance		2,5				
Dielectric Withstanding Resistance		3,6				
Durability	4					
Mating Force	2					
Humidity Test	6	4				
Salt Spray			2			
Temperature Life				2		
Solderability					1	
Resistance to soldering heat					2	
Contact Normal Force						1

Figure 2

NOTE : (a) Numbers indicate sequence in which tests are performed.

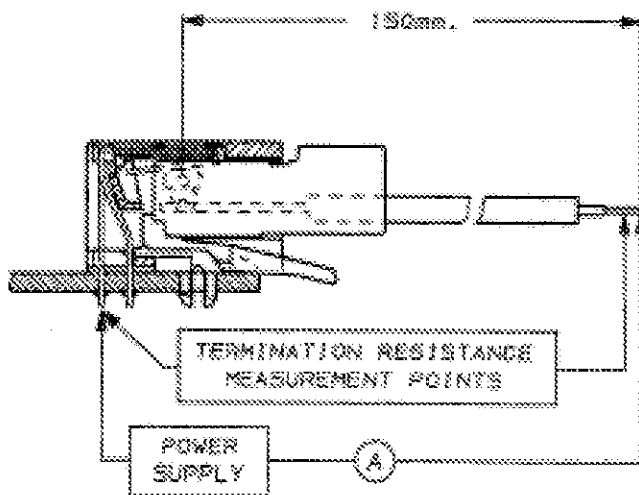
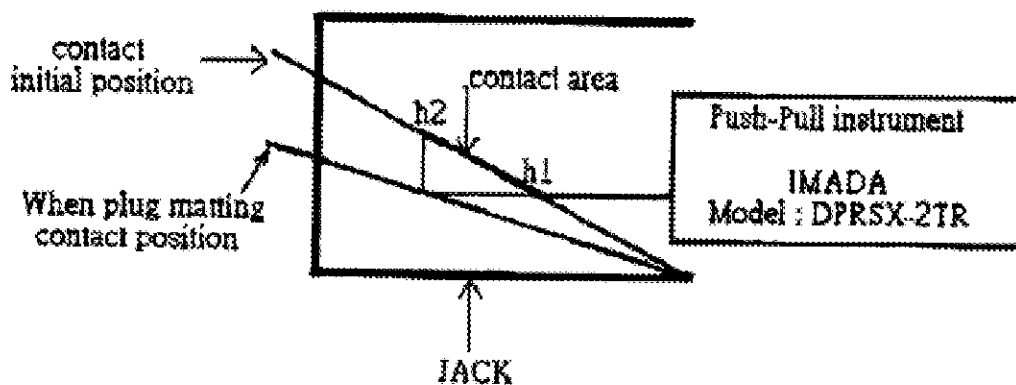

Figure 1



Contact area (from h1 to h2) is the trace of attrition , when plug matting

Figure 2

4.1 QUALIFICATION TESTING

A. Test Samples

The test samples consisted of 30pcs, which were divided into 6 Groups (A, B, C, D, and E, F) with 5pcs. In each group for each corresponding test group defined in Table 2.

B. Test Condition

Unless otherwise specified, all tests shall be performed under any combination of the following test conditions:

Temperature: 15 – 30° C

Relative Humidity: 45 – 75%

Atmospheric Pressure: 650 – 800 mmHg

4.2 RE-QUALIFICATION TESTING

If changes significantly affecting form, fit or function are made to product or manufacturing process, product assurance shall coordinate re-qualification testing, consisting of all or part of original testing sequence as determined by development/product, quality and reliability engineering.

4.3 ACCEPTANCE

Acceptance is based on verification that product meets requirements Spelled in Table 2. Data attributed to equipment; test setup or operator deficiencies shall not disqualify product. When product failure occurs, corrective action shall be taken and samples resubmitted for qualification. Testing to confirm corrective action is required before resubmit.

4.4 QUALITY CONFORMANCE INSPECTION

Applicable AMP quality inspection plan will specify sampling acceptable quality level to be used. Dimension and functional requirements shall be in accordance with applicable product drawing and this specification.