Board-To-Board Connector

1. SCOPE

1.1. Contents

This specification covers the performance, tests and quality requirements for the Tyco Electronics Board-To-Board connector.

1.2. Qualification

When tests are performed on the subject product line, procedures specified in Figure 1 shall be used. All inspections shall be performed using the applicable inspection plan and product drawing.

2. APPLICABLE DOCUMENT

The following documents form a part of this specification to the extent specified herein. Unless otherwise specified, the latest edition of the document applies. In the event of conflict between the requirements of this specification and the product drawing, the product drawing shall take precedence. In the event of conflict between the requirements of this specification and the referenced documents, this specification shall take precedence.

2.1. Tyco Electronics Documents

- TEC-109-201: Component Heat Resistance to Lead-Free Reflow Soldering.
- 501-57880: Qualification Test Report.

2.2. Commercial Standard

- EIA-364: Electrical Connector/Socket Test Procedures Including Environmental Classifications.
- JESD22-B102D: Solderability Test Method.

3. REQUIREMENTS

3.1. Design and Construction

Product shall be of the design, construction and physical dimensions specified on the applicable product drawing.

3.2. Materials

Materials used in the construction of this product shall be as specified on the applicable product drawing.

3.3. Ratings

- A. Voltage: 50 volts AC.
- B. Current: 0.5 amperes.
- C. Temperature: -25 to 85°C.

3.4. Performance Requirement and Test Description

Product is designed to meet the electrical, mechanical and environmental performance requirements specified in Figure 1. Unless otherwise specified, all tests shall be performed at ambient environmental conditions per EIA-364.

3.5. Test Requirements and Procedures Summary

Test Description	Requirement	Procedure
Examination of product.	Meets requirements of product drawing.	EIA-364-18. Visual and dimensional (C of C) inspection per product drawing.
ELECTRICAL		
Low level contact resistance.	40 mΩ maximum initial. 60 mΩ maximum final.	EIA-364-23. Subject specimens to 100 mA maximum and 20 mV maximum open circuit voltage.
Insulation resistance.	100 MΩ minimum initial. 50 MΩ minimum final.	EIA-364-21. Test between adjacent contacts of unmated specimens.
Dielectric withstanding voltage.	1 minute hold with no breakdown, flashover, or 0.5 mA maximum leakage.	EIA-364-20, Condition I. 250 volts AC at sea level. Test between adjacent contacts of unmated specimens.
MECHANICAL		
Mating force.	150 gf per contact maximum.	EIA-364-13. Measure force necessary to mate specimens with test boards at a maximum rate of 25 mm per minute.
Unmating force.	20 gf per contact minimum.	Measure force necessary to unmate specimens with test boards at a maximum rate of 25 mm per minute.
Contact retention force.	200 gf per contact minimum.	EIA-364-29. Apply axial load to contacts in vertical direction.
Durability.	See NOTE	EIA-364-9. Mate and unmate specimens with test boards for 30 cycles at a maximum rate of 25 cycles per minute.
Vibration, sinusoidal.	No discontinuities of 1 microsecond or longer duration. See NOTE	EIA-364-28, Condition I. Subject mated specimens to 10-55-10 Hz traversed in 1 minute with 1.52 mm maximum total excursion. 2 hours in each of 3 mutually perpendicular planes.
ENVIRONMENTAL		
Solderability.	The inspected area of each lead must have 95% solder coverage minimum.	JESD22-B102D, Condition A. Steam Aging Preconditioning: 93 +3/-5°C, 1 hour ±5 min. Reflow Temperature: 230-245°C Reflow Time: 50-70 s.
Humidity-temperature cycling.	See NOTE	EIA-364-31, Method III, Condition A. Subject mated specimens to 4 cycles 96 hours between 25 and 65°C at 90 to 95% R.H.
Resistance to reflow soldering heat.	See NOTE	TEC-109-201, Condition B. Moisture Soak Preconditioning: 85°C and 85% R.H. for 168 hours. Preheat Temp.: 150-200°C, 60-180 s. Time over liquidus (217°C): 60-150 s. Peak Temp.: 260 +0/-5°C, 20-40 s. Duration: 3 cycles.

NOTE Shall meet visual requirements, show no physical damage, and meet requirements of additional tests as specified in the Product Qualification and Requalification Test Sequence shown in Figure 2.

Figure 1

3.6. Product Qualification and Requalification Test Sequence

Test or Examination	Test Group (a)							
	A	B	C	D	E	F	G	H
	Test Sequence (b)							
Examination of product.	1, 6	1, 4	1, 3	1, 5	1, 3	1, 8	1, 5	1, 3
Low level contact resistance.	2, 5			2, 4		2, 7	2, 4	
Insulation resistance.	3					3, 6		
Dielectric withstanding voltage.	4					4		
Mating force.		2						
Unmating force.		3						
Contact retention force.			2					
Durability.				3				
Vibration, sinusoidal.					2			
Solderability.								2
Humidity-temperature cycling.						5		
Resistance to reflow soldering heat.							3	

NOTE (a) See paragraph 4.1.A.
 (b) Numbers indicate sequence in which test are performed.

Figure 2

4. QUALITY ASSURANCE PROVISIONS

4.1. Qualification Testing

A. Specimen Selection

Specimens shall be prepared in accordance with applicable Instruction Sheets and shall be selected at random from current production. All test groups shall each consist of a minimum of 5 specimens.

B. Test Sequence

Qualification inspection shall be verified by testing specimens as specified in Figure 2.

4.2. Requalification Testing

If changes significantly affecting form, fit or function are made to the product or manufacturing process, product assurance shall coordinate requalification testing, consisting of all or part of the original testing sequence as determined by development/product, quality and reliability engineering.

4.3. Acceptance

Acceptance is based on verification that the product meets the requirements of Figure 1. Failures attributed to equipment, test setup or operator deficiencies shall not disqualify the product. If product failure occurs, corrective action shall be taken and specimens resubmitted for qualification. Testing to confirm corrective action is required before resubmittal.

4.4. Quality Conformance Inspection

The applicable quality inspection plan shall specify the sampling acceptable quality level to be used. Dimensional and functional requirements shall be in accordance with the applicable product drawing and this specification.

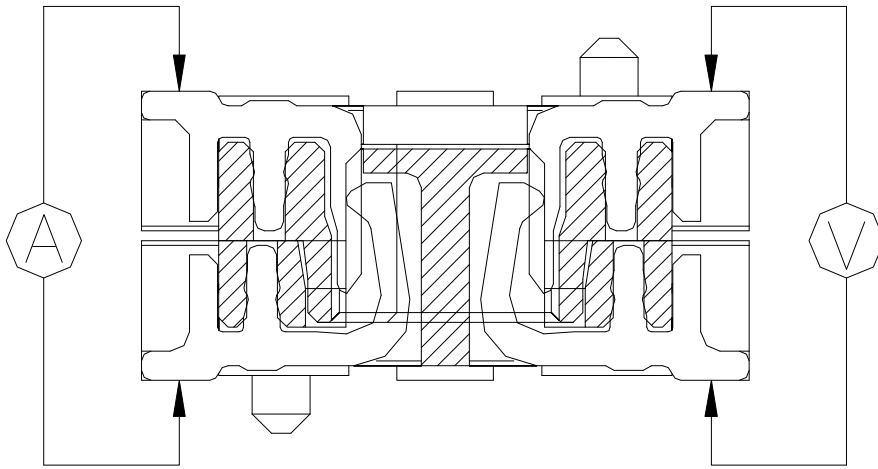

Low Level Contact Resistance Measurement Points

Figure 3

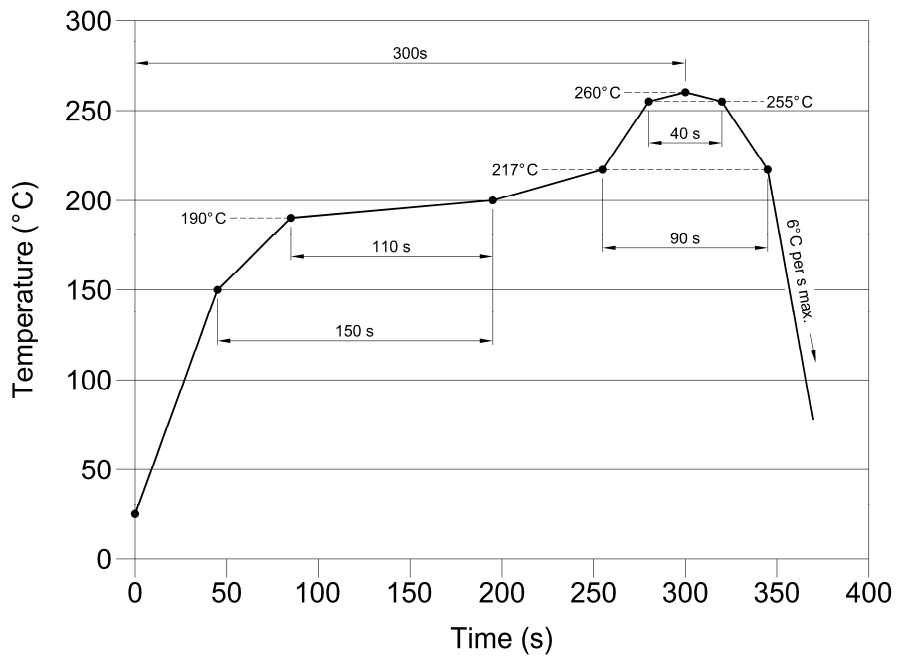

Temperature Profile of Reflow Soldering

Figure 4