

1.Scope :**1.1 Contents**

This specification covers the requirements for product performance, test methods and quality assurance provisions of MICRO SD SOCKET. Applicable product description and part numbers are as shown in Appendix 1.

2. Applicable Documents:

The following documents form a part of this specification to the extent specified herein. In the event of conflict between the requirements of this specification and the product drawing, the product drawing shall take precedence. In the event of conflict between the requirements of this specification and the referenced documents, this specification shall take precedence.

2.1TE Specifications :

- A. 109-5000 : Test Specification, General
Requirements for Test Methods
- B. 501-78508 : Test Report

2.2 Commercial Standards and Specifications :

- A. MicroSD Memory Specification : MicroSD Memory Card application Notes
- B. Military Standard :MIL STD.202

3. Requirements :

3.1 Design and Construction :

Product shall be of the design, construction and physical dimensions specified on the applicable product drawing.

3.2 Materials :

A. Contact :

Material : Copper Alloy

Finish : Gold in Contact area and Soldering area

Nickel under coat all over

B. Housing, Slider : Material : LCP

Flammability : UL94V-0

C. Camrod

Material : Stainless steel

D. Coil spring

Material : SWP

E. Hook spring

Material : Stainless steel

F. Shell

Material : Copper Alloy

Finish : Gold in Soldering area

Nickel under coat all over

3.3 Ratings :

A. Voltage Rating : 10V DC

B. Current Rating : 0.5A MAX,

C. Operating Environment

Operating Temperature Rating : -30 °C to +105 °C

Relative Humidity: 95% Max.(non-condensing)

※High Limit temperature includes Raised Temperature by Operation.

D. Storage Environment

Storage Temperature Rating : -5 °C to +85 °C(with Packing)

Component must withstand in Mobile phone storage -40°C to +85 °C (16h)

3.4 Performance Requirements and Test

Descriptions :The product shall be designed to meet the electrical, mechanical and environmental performance requirements specified in Fig. 1. All tests shall be performed in the room temperature(5~35°C),relative humidity(45~85%)、Air pressure(85~106kPa), unless otherwise specified.

3.5 Test Requirements and Procedures Summary

Para.	Test Items	Requirements	Procedures
3.5.1	Examination of Product	No physical damage	Visual inspection No physical damage
Electrical Requirements			
3.5.2	Contact Resistance (Low Level)	Initial Contact Resistance 40 mΩ Max. Max Contact Resistance after group testing 80 mΩ Max. Initial and final SW Contact Resistance 400 mΩ Max. Contact resistance includes also the bulk resistance due to terminal After any environmental test for every contact	Mate Connector with Dry circuit (20mV, 100mA Max.) at min. deflection position Refer to Fig.3 (IEC 60512-2-1)
3.5.3	Dielectric withstanding Voltage	No voltage breakdown Current leakage : 1mA Max.	Unmated Connector with 500 VAC between adjacent contact for 1 minute (IEC 60512-3-1)
3.5.4	Insulation Resistance	1000MΩ Min. (Initial) 100 MΩ Min. (Final)	Unmated Connector with 500 VDC between adjacent contact for 1 minute (IEC 60512-3-1)
3.5.5	Temperature Rise	30°C Max under loaded rating Current.(0.5A)	Contacts series-, apply test current of loaded rating current of the circuit ,and measure the temperature rising by probing on soldered areas of contacts, after the temperature becomes stabilized Deduct ambient temperature from the measured value Refer to Fig.5

Fig. 1 (CONT.)

Para.	Test Items	Requirements	Procedures
Mechanical Requirements			
3.5.6	Durability	Contact resistance: 80 mΩ Max.	Mating contacts at 4-10 cycles/minute, including pause between mate/unmate to 10000 cycles After every 10 (max.) cycles blow with dry air
3.5.7	Wrongly insertion test Card upside down (signal pads pointing away from PWB)	20 N Min.	Card is guide so that the slider mechanism is pushed inwards and the wrong card insertion prevent feature is by passed
Environmental Requirements			
3.5.8	Dry cold (steady state)	Contact resistance: 80 mΩ Max.	- 40°C for 96hours; recovery period 1-2hours under ambient atmospheric conditions (IEC60068-2-1Ab)
3.5.9	Dry heat (steady state)	Contact resistance: 80 mΩ Max.	+85°C for 96 hours; recovery period 1-2hours under ambient atmospheric conditions (IEC60068-2-2Bb)
3.5.10	Thermal Shock (Change of temperature)	Contact resistance: 80 mΩ Max.	25 cycle at Ta = - 55 °C for 0.5 hours; then change of temp=25°C Maximum 5 min; then Tb=+85°C for 0.5 hours; then cool to ambient Recovery: 2 hours at ambient atmosphere
3.5.11	Dump heat cyclic	Contact resistance: 80 mΩ Max.	Mated Dummy card(PCB)., -10~65°C, 80~98%R.H. 10 cycles MIL-STD-202 Method 106

Fig. 1 (CONT.)

Para.	Test Items	Requirements	Procedures
3.5.12	Salt spray	Contact resistance: 80 mΩ Max.	48 hour spray, at temp. 35°±2°c R/H 90-95% Salt NaCl mist 5% After test wash parts and return to room ambient for 1-2 hours (IEC 60068-2-11 Test)
3.5.13	Mixed Gas	Contact resistance: 80 mΩ Max.	96 hours H2S 0.1 ppm+SO2 0.5 ppm At temp. 25°±1°c R/H 75 ±3 % After test return to ambient temp for 1-2hours (IEC 60068-2-60 Test IEC60512-11-7)
3.5.14	Vibration (random)	Discontinuity during testing < 1 μs with all contacts in series No mechanical damage No change to performance Contact resistance: 80 mΩ Max.	Frequency: 10 - 100 Hz; 3 m2/s3 (0.0132 g2/Hz) ; 100 - 500 Hz; -3dB/Oct. for: 3 x 60 min (X- Y- and Z-axis)
3.5.15	Shock (specified pulse)	Discontinuity during testing < 1 μs with all contacts in series No mechanical damage No change to performance Contact resistance: 80 mΩ Max.	Pulse shape=half sine Peak acceleration =50G Duration of pulse=11ms Apply 3 shocks in each direction along the 3 mutually perpendicular axes (18 shocks) (IEC60068-2-27Ea)
3.5.16	Solderability	Wet Solder Coverage : 90% Min.	Solder Temperature : 245±3 °C Immersion Duration : 3±0.5 seconds Solder : Su-3Ag-0.5Cu Flux : RMA25%
3.5.17	Resistance to Reflow Soldering Heat	Tested housing shall show no evidence of deformation or fusion of housing and no physical damage	Test connector on PCB. Pre-Heat 150~180°C : 90±30sec. Heat 230°C : 30±10sec. Heat Peak 255°C Refer to Fig 4

Fig. 1 (End)

The applicable product descriptions and part numbers are as shown in Appendix. 1.

Product Part No.	Description
2201778-1	Micro SD SOCKET

Appendix 1

Product Qualification Test Sequence

Test Examination	Test Group									
	1	2	3	4	(b)5	6	7	8	9	10
	Test Sequence (a)									
Examination of Product	1	1	1	1	1	1	1	1	1	1
Contact Resistance (Low Level)	2,8	2,5	2,4	2,4	2,6	2,4				
Dielectric withstanding Voltage	4,7									
Insulation Resistance	3,6									
Temperature Rise							2			
Durability						3				
Wrongly insertion force								2		
Dry cold (steady state)		3								
Dry heat (steady state)		4								
Thermal Shock					3					
Damp heat (cyclic)	5									
Salt spray			3							
Mixed Gas				3						
Vibration (random)					4					
Shock (specified pulse)					5					
Solderability									2	
Resistance to Reflow Soldering Heat										2

(a) Numbers indicate sequence in which the tests are performed

(b) Discontinuities shall nit take place in this test group,during tests

Fig. 2

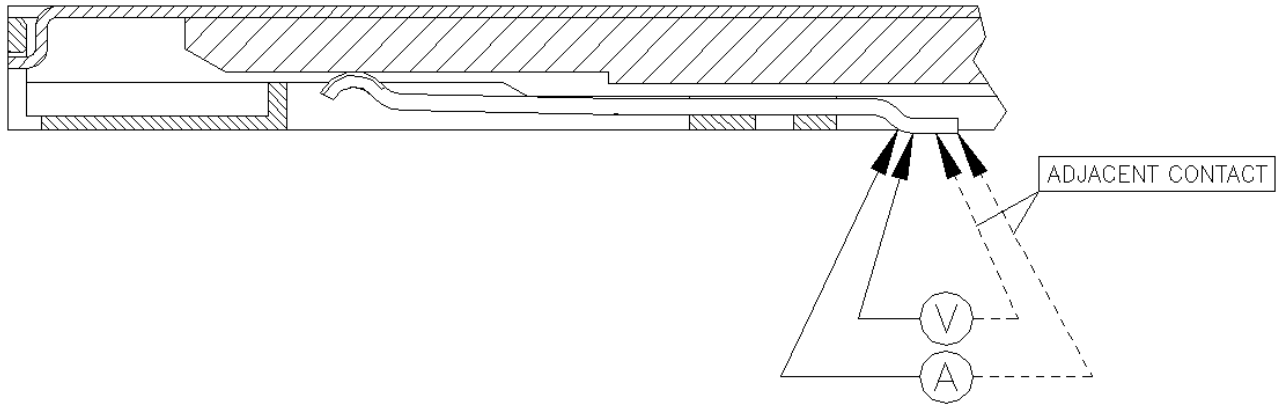

Fig.3 Termination Resistance Measuring points

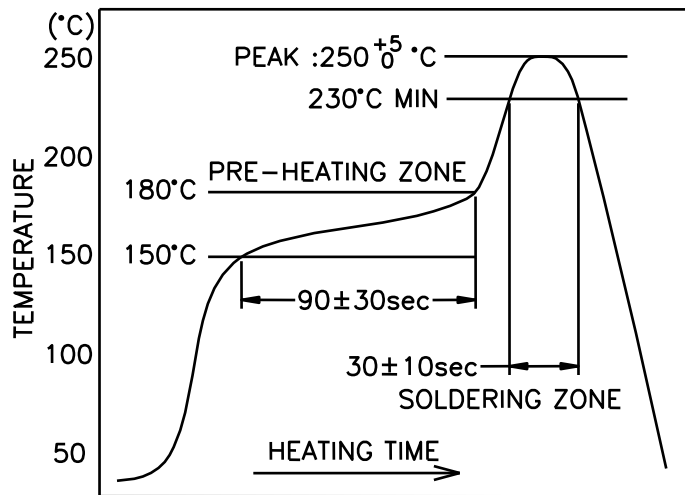

FIG.1 REFLOW TEMPERATURE PROFILE

Fig.4 Reflow temperature profile

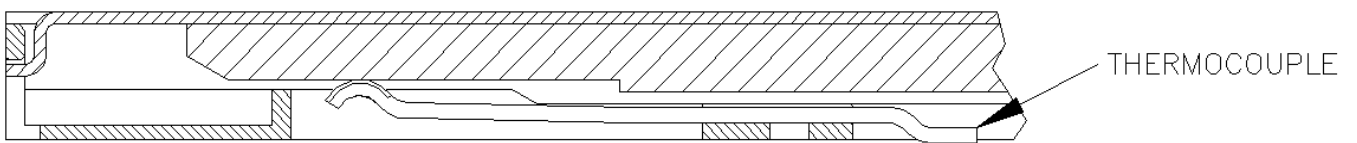

Fig.5 Temperature Resistance Measurement