Rotary Cam Actuated Zero Insertion Force Edge Connector

1. SCOPE

1.1. Content

This specification covers the performance, tests and quality requirements for the AMP* rotary cam actuated zero insertion force edge connector. This connector is a multi-contact, edge board type assembly having .025 square or .016 x .025 posted contacts of various lengths for plug-on, wrap or solder application. This connector has the capability of making sequential or non-sequential contact with the mating printed wiring board.

1.2. Qualification

When tests are performed on the subject product line, the procedures specified in AMP 109 series specifications shall be used. All inspections shall be performed using the applicable inspection plan and product drawing.

2. APPLICABLE DOCUMENTS

The following documents form a part of this specification to the extent specified herein. In the event of conflict between the requirements of this specification and the product drawing, the product drawing shall take precedence. In the event of conflict between the requirements of this specification and the referenced documents, this specification shall take precedence.

2.1. AMP Specifications

- A. 109-1: General Requirements for Test Specifications
- B. 109 Series: Test Specifications as indicated in Figure 1.
(Comply with MIL-STD-202, MIL-STD-1344 and EIA RS-364)
- C. Corporate Bulletin 76: Cross-reference between AMP Test Specifications and Military or Commercial Documents
- D. 118-14002: Cleaning, ZIF Connectors and Printed Circuit Boards

2.2. Military Standard

- MIL-STD-275: Printed Wiring for Electronic Equipment

2.3. Military Specification

MIL-C-21097: Connector, Electrical, Printed Wiring Board, General Purpose

3. REQUIREMENTS

3.1. Design and Construction

Connectors shall be of the design, construction and physical dimensions specified on the applicable product drawing.

3.2. Materials

- A. Contact: Phosphor bronze, gold over nickel
- B. Housing: Thermoplastic, glass filled, UL 94V-O

3.3. Ratings

- A. Current: 3 amperes maximum per contact, see Para 3.5. (a)
- B. Operating Temperature: -55° to 105°C

3.4. Performance and Test Description

Connectors shall be designed to meet the electrical, mechanical and environmental performance requirements specified in Figure 1.

3.5. Test Requirements and Procedures Summary

Test Description	Requirement	Procedure
Examination of Product	Meets requirements of product drawing.	Visual, dimensional and functional per applicable inspection plan.
ELECTRICAL		
Termination Resistance, Rated Current (c)	20 milliohms maximum.	Measure potential drop of mated contacts assembled in housing at 3 amperes maximum, see Figure 3; AMP Spec 109-25, calculate resistance.

Figure 1 (cont)

Test Description	Requirement	Procedure								
Termination Resistance, Dry Circuit (c)	20 milliohms maximum.	Subject mated contacts assembled in housing to 50 mv open circuit at 100 ma maximum, see Figure 3; AMP Spec 109-6-1.								
Dielectric Withstanding Voltage	<table border="1"> <thead> <tr> <th>Centerline Spacing</th> <th>Test Voltage rms</th> </tr> </thead> <tbody> <tr> <td>.100</td> <td>800</td> </tr> <tr> <td>.125</td> <td>1200</td> </tr> <tr> <td>.156</td> <td>1500</td> </tr> </tbody> </table> 5 milliamperes maximum leakage current.	Centerline Spacing	Test Voltage rms	.100	800	.125	1200	.156	1500	Test between adjacent contacts of unmated connector and contacts to mounting hardware; AMP Spec 109-29-1.
Centerline Spacing	Test Voltage rms									
.100	800									
.125	1200									
.156	1500									
Insulation Resistance	5000 megohms minimum initial.	Test between adjacent contacts of unmated connector assembly; AMP Spec 109-28-4.								
MECHANICAL										
Vibration (b)	No discontinuities greater than 1 microsecond.	Subject mated connectors with printed circuit boards to 10 G's, 10-500 Hz with 100 ma current applied; AMP Spec 109-21-2.								
Physical Shock (b)	No discontinuities greater than 1 microsecond.	Subject mated connectors with printed circuit boards to 100 G's sawtooth in 6 milliseconds; 3 shocks in each direction applied along the 3 mutually perpendicular planes total 18 shocks; AMP Spec 109-26-9.								
Contact Retention	Contacts shall not dislodge from the connector; contact sequencing.	Apply axial load to contact posts: .025 square: 10 pounds .016 x .025: 6 pounds; AMP Spec 109-30.								

Figure 1 (cont)

Test Description	Requirement	Procedure
Contact Separating Force	.50 ounces minimum per contact pair.	Actuate 3 times with specified cam key; check with minimum thickness gage .054 inch, with cam key in place but not actuated; AMP Spec 109-35.
Durability	No evidence of physical damage, contact separating force; cam actuating torque; contact sequencing.	Using a polished steel blade per MIL-C-21097, in place open and close for 5000 cycles at a rate of 400 to 600 cycles per hour.
Cam Actuating Torque	.75 inch ounce maximum per contact.	Test unmated connector using full length cam key with specified cross-section.
Contact Sequencing	Contacts make and break contact, with board, in proper sequence.	Using printed wiring board check sequencing per product drawing.
ENVIRONMENTAL		
Thermal Shock	No evidence of physical damage.	Subject mated connectors to 5 cycles between -55° and 105°C; AMP Spec 109-22.
Humidity, Steady State	Insulation resistance; dielectric withstanding voltage.	Subject unmated connectors to steady state humidity at 40°C and 90-95% RH; AMP Spec 109-23, method II, cond A.

- (a) Maximum rated current that can be carried by this product is limited by maximum operating temperature of housings, which is 105°C, and temperature rise of contacts, which is 30°C. Variables which shall be considered for each application are: wire size, connector size, contact material, and ambient temperature.
- (b) Shall remain mated and show no evidence of damage, cracking or chipping.
- (c) Connectors and boards shall be cleaned using the procedures as outlined in Process Specification 118-14002, prior to each mating.

Figure 1 (end)

3.6. Connector Qualification and Requalification Tests and Sequences

Test or Examination	Test Group (a)	
	1	2
	Test Sequence (b)	
Examination of Product	1	1
Termination Resistance, Rated Current	3,16	4,14
Termination Resistance, Dry Circuit	2,15	3,13
Dielectric Withstanding Voltage	5,14	
Insulation Resistance	4,13	
Vibration		11
Physical Shock		12
Contact Retention	17	15
Contact Separating Force	10	5,9
Durability (c)	8	7
Cam Actuating Torque (c)	9	2,8
Contact Sequencing	6,11,18	6,10,16
Thermal Shock	7	
Humidity, Steady State	12	

(a) See Para 4.1.A.

(b) Numbers indicate sequence in which tests are performed.

(c) See Figure 4.

Figure 2

4. QUALITY ASSURANCE PROVISIONS

4.1. Qualification Testing

A. Sample Selection

Connector housings and contacts shall be prepared in accordance with applicable Instruction Sheets. They shall be selected at random from current production. Test groups 1 and 2 shall consist of 6 connectors containing the largest number of contact positions available at time of test, 3 each per group. Test group 2 shall also contain 2 additional specimens from the least number of positions available.

B. Test Sequence

Qualification inspection shall be verified by testing samples as specified in Figure 2.

C. Acceptance

- (1) Test results from development on pre-qualification samples will be used to determine upper and lower one-sided statistical tolerance limits for 99% reliability at 95% confidence, as follows. Let \bar{X} and s denote the sample average and standard deviation, respectively, of the test data. Let k denote the normal distribution one-sided tolerance factor for 95% confidence and 99% reliability. The value of k varies with sample size. Values of k are given in various tables, for example, NBS Handbook 91, Factors for One-Sided Tolerance Limits for Normal Distribution. Suitability of the normal distribution for representing the data shall be verified with normal probability plots, goodness of fit tests, etc.

Then the upper one-sided tolerance limit for 99% reliability at 95% confidence is given by $\bar{X} + ks$. The interpretation of this tolerance limit is as follows: based on the test data, and assuming a normal distribution for the test data, we can be 95% confident that 99% of the population of values represented by the sample data will not exceed $\bar{X} + ks$. For any test parameter for which there is specified an upper requirement which is not to be exceeded, satisfactory performance of the product is achieved when the value of $\bar{X} + ks$ does not exceed the requirement value.

The lower one-sided tolerance limit for 95% confidence and 99% reliability is given by $\bar{X} - ks$. This has a similar interpretation and corresponding application to lower requirement values.

- (2) Failures attributed to equipment, test setup, or operator deficiencies shall not disqualify the product. When product failure occurs, corrective action shall be taken and samples resubmitted for qualification.

4.2. Requalification Testing

Requalification shall be established by the cognizant divisional engineering function and may consist of all or any part of the overall qualification program provided that it is conducted within the required time period.

4.3. Quality Conformance Inspection

The applicable AMP inspection plan will specify the sampling acceptable quality level to be used. Dimensional and functional requirements shall be in accordance with the applicable product drawing and this specification.

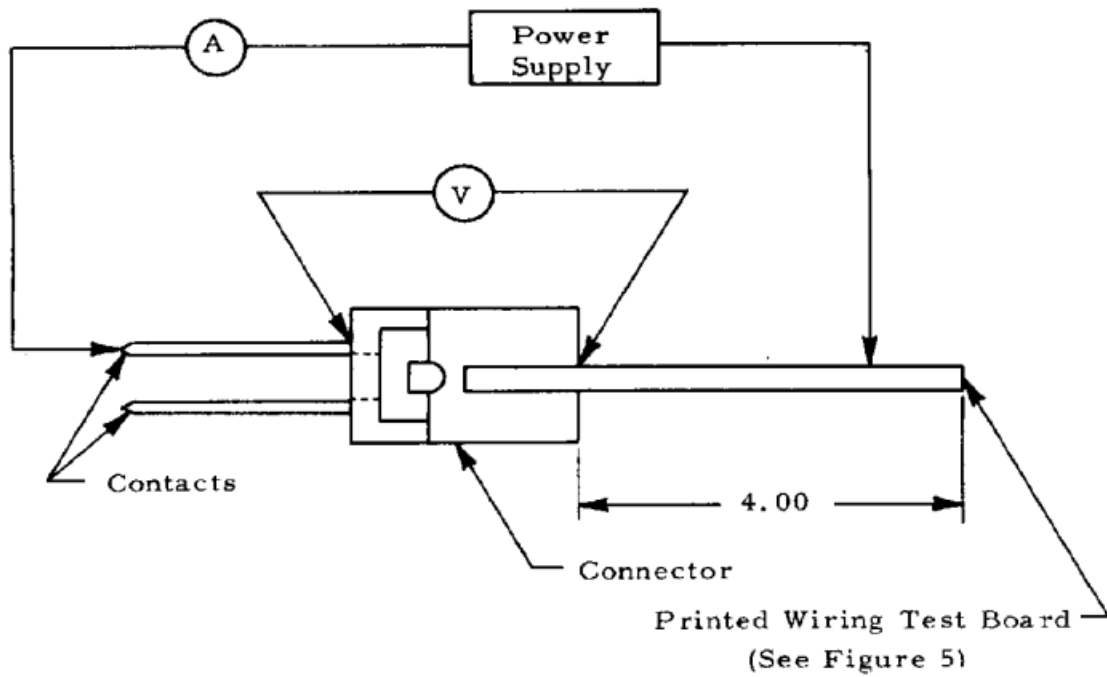
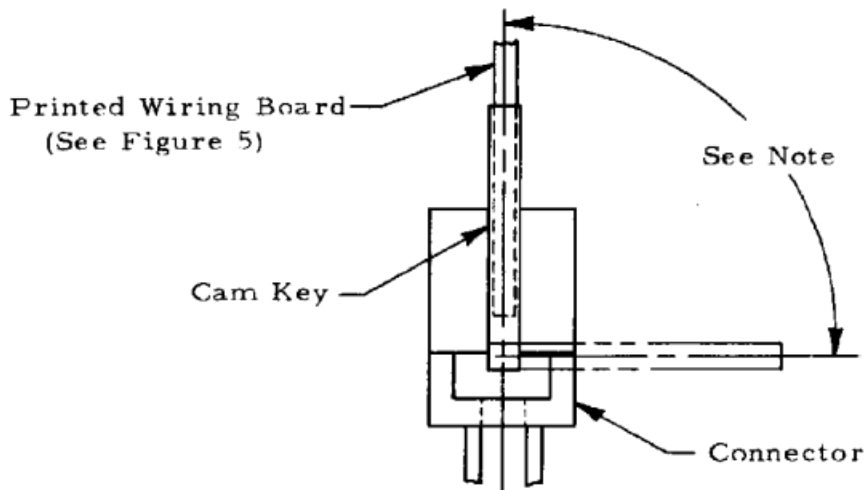

Figure 3

Termination Resistance Test Circuit



Note: One durability cycle constitutes actuation of cam key 90° from vertical in clockwise direction and returning to vertical position and shall be conducted with a printed wiring board in place. Cam actuating torque is conducted without a printed wiring board in place.

Figure 4

Cam Actuating Torque and Durability Test Setup

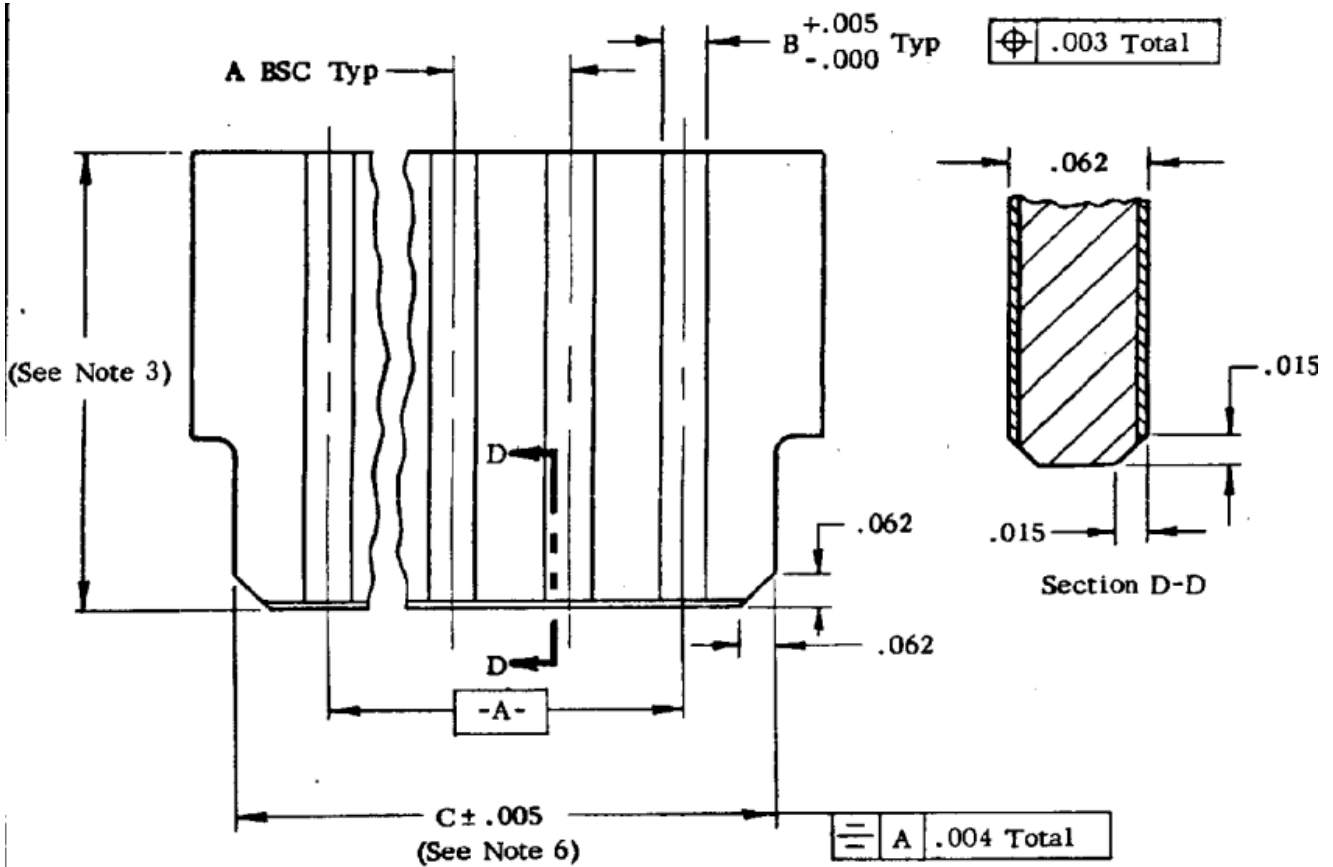

Connector Contact Spacing	A BSC	B
.100	.100	.052
.125	.125	.078
.156	.156	.094

Notes:

1. Dimensions are in inches.
2. Unless otherwise specified, tolerance is $\pm .005$.
3. The test card shall extend $4.00 \pm .02$ from the receptacle after insertion.
4. Number of contacts shall be the same as on the corresponding printed wiring connector.
5. Printed circuit test board shall be 2 oz copper and gold over nickel plated per MIL-STD-275.
6. This dimension shall be the minimum connector card slot length minus .008.
7. Conductor configuration optional beyond card slot depth.
8. Printed wiring shall be identical on both sides.

Figure 5
Printed Wiring Board