

Class 1

| | |
|---|--|
|  | <p style="text-align: center;">CI 1-32/500</p> <p style="text-align: center;">Product Specification Vehicle</p> <p style="text-align: center;">Charge Inlet Type CCS1-120mm²</p> |
|---|--|

TABLE OF CONTENTS

| | |
|--|----|
| 1. Scope..... | 2 |
| 1.1. Introduction..... | 2 |
| 2. APPLICABLE DOCUMENTS | 3 |
| 2.1. TE Connectivity Documents | 3 |
| 2.2. Other Documents..... | 4 |
| 3. REQUIREMENTS..... | 5 |
| 3.1. Design and Construction | 5 |
| 3.2. Material | 5 |
| 3.3. Product Ratings | 5 |
| 3.4. Performance requirements and Test descriptions..... | 7 |
| 3.5. Test Requirements and procedures summary: | 8 |
| 4. Temperature Rise curves:..... | 11 |
| 4.1. 500A T-Rise curve | 11 |
| 4.2. 600A T-Rise curve | 12 |
| 4.3. 700A T-Rise curve | 12 |

PRELIMINARY

1. SCOPE

1.1. Introduction

The TE CCS1 charging inlet was designed to power electric and hybrid vehicles that comply with standard IEC 62196-3.

The maximum rated current for AC is 32A at the maximum voltage of 250V.

The maximum rated current for DC is 500A continuously with cooled connector and 1000V.

The maximum rated current for DC is 600A for 50min with cooled connector and 1000V.

The maximum rated current for DC is 700A for 8min with cooled connector and 1000V.

The maximum rated current for DC is 335A with uncooled connector and 1000V.

The content of this specification covers the technical characteristics, performance and test requirements for the EV CHARGE INLET Combined Charging System Type 1 further mentioned as CCS1.

When tests are performed the following specifications and standards shall be used. All inspections shall be performed using the applicable inspection plan and customer drawing.

2. APPLICABLE DOCUMENTS

The following mentioned documents are part of this specification. Unless otherwise specified, the latest edition of the documents applies. In the event of conflict between the requirements of this specification and the information contained in the referenced documents, this specification shall take precedence.

2.1. TE Connectivity Documents

General Requirements

| Requirement | Description |
|--------------|----------------------------------|
| 109-1 Rev. J | General Requirements for Testing |

Table 1

Drawings

Optinal LED indicators, for more information see CD drawings.

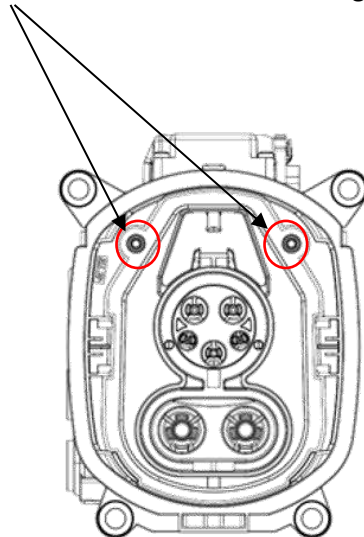

| Drawing | Description |
|------------|--------------------------|
| CD-2402048 | Charge Inlet, Assy, CCS1 |

Table 2

Specifications

| Specification | Description |
|---------------|--|
| 114-94758 | Application Specification EV Charge Inlet CCS1 |
| 114-94842 | Ultrasonic Weld Connection Spec. (180° DC-Contact) |
| 114-13000 | Micro MATE-N-LOK Connectors |
| 108-94519 | Actuator-Specification |

Table 3

2.2. Other Documents

| Specification | Description |
|----------------------|--|
| IEC 62196-1: 2014/06 | General requirements |
| IEC 62196-2: 2016/02 | Dimensional compatibility and interchangeability requirements for AC pin and contact-tube accessories |
| IEC 62196-3: 2014/06 | Dimensional compatibility and interchangeability requirements for DC and AC/DC pin and contact-tube vehicle couplers |
| SAE J1772: 2016/02 | SAE Electric Vehicle and Plug in Hybrid Electric Vehicle Conductive Charge Coupler |

Table 4

3. REQUIREMENTS

3.1. Design and Construction

The product has been designed to withstand its environment and the effects it has on it.

3.2. Material

The Material data is available in the IMDS (International Material Data System of the Automotive Industry).

3.3. Product Ratings

Dimensions

Mating-Face Geometry

compatible with IEC 62196-2 Sheet 2-I
and IEC 62196-3 Sheet 3-IIIa

Screw Points

See Drawing

Environmental conditions

Ambient temperature

-40 °C +50 °C

Max. altitude

5000m above sea-level

Protection degree

IP5KX with flaps closed condition
IP6KX with flaps opened condition
IPX7 Temp. reduce to 85°C

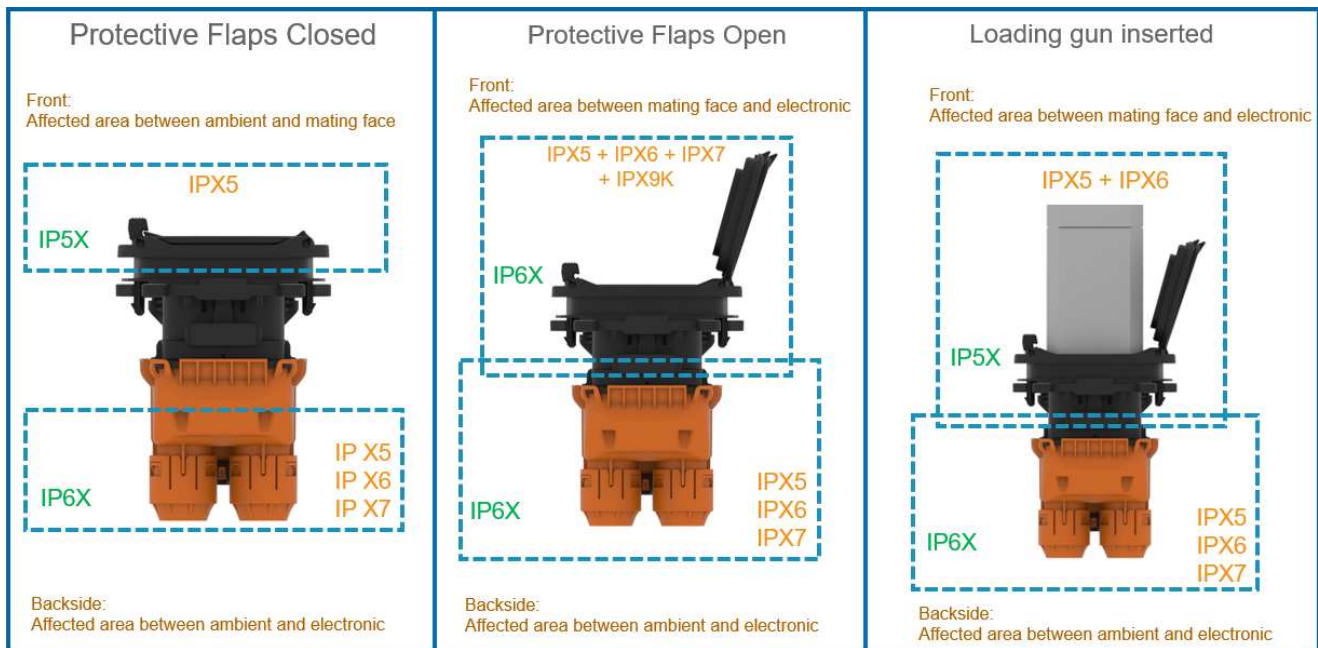

Figure 2

Electrical Properties

| | |
|--|--|
| Max. charging performance | 11 kW (AC) / 500 kW (DC) |
| Type of charging current | AC / DC |
| Number of AC-phases | 1 |
| Number of Terminals | 7 (PE, L1, L2/N, DC+, DC-, CS, CC) |
| Rated current | 32A AC / 500A DC |
| Rated voltage | 250V AC / 1000V DC |
| Signal pin rated current | 2A |
| Signal pin rated voltage | 30V |
| Type of signal transmission | Analog |
| Insulation resistance of adjacent contacts | 200MΩ |
| Resistant coding | acc. IEC 61851-1 |
| Light Option | White/Green/Red/Blue nom. Voltage 11V/20mA Allowed Voltage Range 8...16V |

Mechanical Properties

| | |
|---|--|
| Mating / un-mating endurance | <= 10000 cycles |
| Insertion force | typical <100N (depending on connector) |
| Retention force | typical <100N (depending on connector) |
| Mechanical Stability of charging socket | max. 500N in all directions (max. Lever-Length 100mm) |
| Vibration Level | ISO 16750-3 Test VII |

Temperature Sensing

| | |
|---|--|
| Temperature Sensor Type | PT1000 |
| Type of Sensor | DIN EN 60751 Recommended measuring current nominal 0.1mA / max. 1mA continuous or corresponding pulse/pause ratio |
| Temperature Sensor Offset DC (steady state) | max. -5K |
| Temperature Sensor Offset AC (steady state) | -12K TYP. |
| Proposed Shutdown DC | - continuous monitored dT/dt (Temperature rise per time) > 1,5K/sec • Delta T between DC+ and DC- >12K • 85°C measured temperature at sensor (Equivalent to max. contact temperature 90°C) |
| Proposed Shutdown AC | 78°C measured temperature at sensor (Equivalent to max. contact temperature 90°C) |

Actuator

See TE Actuator-Specification TE-108-94519

Installation

Orientation
Max. Angle

see picture below
180°-60°/+5°

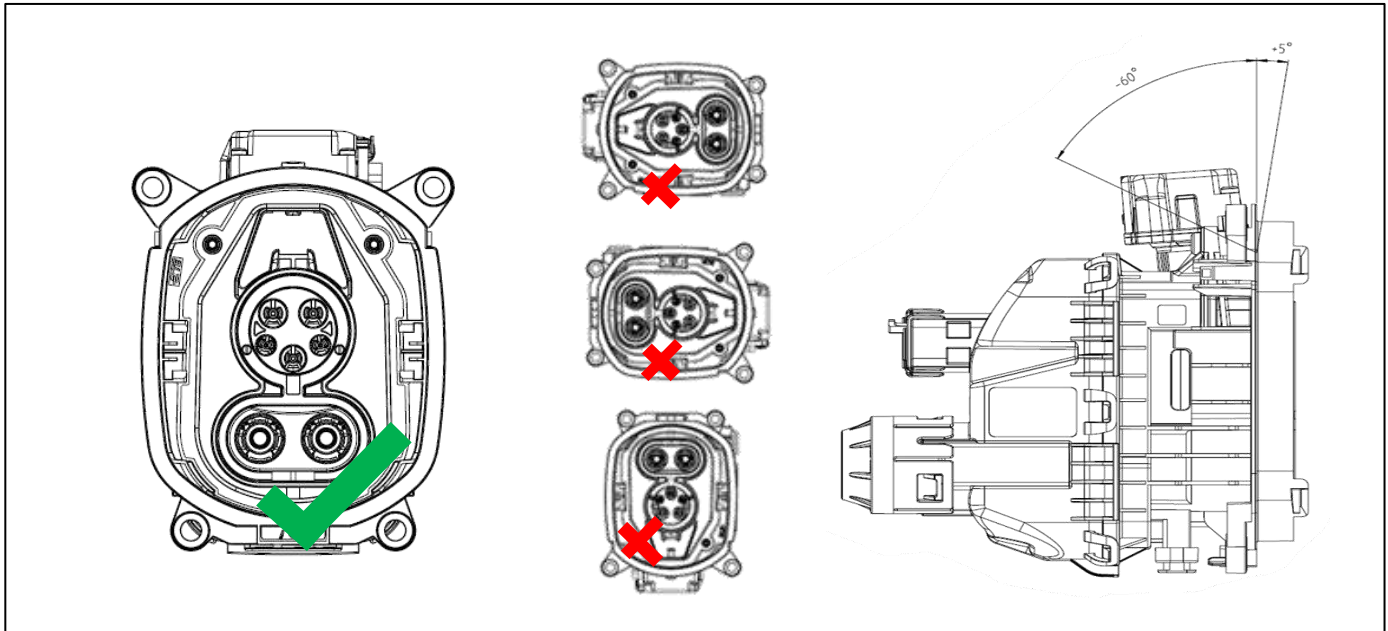

Figure 3

3.4. Performance requirements and Test descriptions

The product shall be designed to meet the electrical, mechanical, and environmental performance requirements specified in table 5. All tests shall be performed in the room temperature, unless otherwise specified.

3.5. Test Requirements and procedures summary:

General Test

| Test Items | Requirements | Procedures |
|---|--|--|
| OPTICAL INSPECTIONS | | |
| Visual and Dimensional examination | Meets requirements of product drawing | Acc. To DIN EN 60512-1-1:2003-01, E 0.1 |
| MECHANICAL INSPECTIONS | | |
| Mechanical stability of the charging socket | Max. Force at initial crack; >500N. | At a mated condition of dummy plug and charge inlet HSG, Max. initial breakage force applied on the dummy plug at 100mm distance recorded. As per Special mechanical test |
| Function of the Primary and Secondary lock / latch play | The latch must be checked by pulling the inserted pins $\leq 10N$ | The primary locking latch device must latch with an audible click while pins insertion and checked by pulling the pins by force $\leq 10N$ Acc. to LV214: 2010-03, E 6.2 |
| | At the final stop, it must be possible to lock the secondary locking device. | At final position of secondary lock, it should be locked. Acc. to LV214: 2010-03, E 6.3 |
| Actuation forces of the secondary lock | Closing forces of the secondary lock Closing Force of Sec. Lock AC $F_C < 50N$ Closing Force of Sec. Lock DC $F_C < 50N$ | The secondary lock actuation from pre-lock to end-lock $F_C < 50N$ Acc. to LV214: 2010-03, E 6.4 |
| | Closing NOK forces of the secondary lock, selectively loaded Closing NOK Force of Sec. Lock AC $F_{C\ NOK} > F_C + 50N$ Closing NOK Force of Sec. Lock DC $F_{C\ NOK} > F_C + 50N$ | The secondary lock actuation from pre-lock to end-lock at contact pin half insertion $F_{C\ NOK} > F_C + 50N$ Acc. to LV214: 2010-03, E 6.4 |

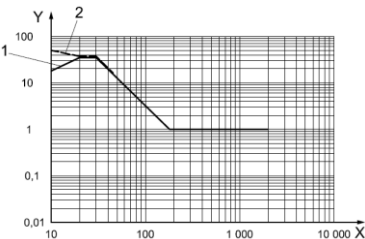
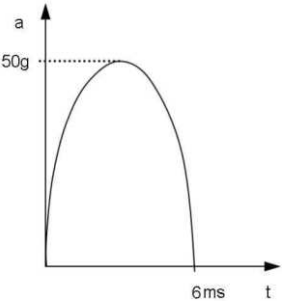
| <p>Contact retention in the charge inlet housing</p> | <p>Contact insertion forces</p> <p>Value Determination</p> <hr/> <p>Contact removal force, Primary lock only</p> <p>Contact Ø3, CP and PP $F_{S \leq 1mm} > 120N$</p> <p>Contact Ø6, PE $F_{S \leq 1mm} > 120N$</p> <p>Contact Ø6, AC $F_{S \leq 1mm} > 120N$</p> <p>Contact Ø8, DC $F_{S \leq 1mm} > 180N$</p> <hr/> <p>Contact removal force, Primary and secondary lock</p> <p>Value Determination</p> | <p>Acc. to LV214:2010-03, E 8.1</p> <hr/> <p>Acc. to LV214:2010-03, E 8.2.1</p> <hr/> <p>-</p> | | | | | | | | | | | | |
|--|--|---|-----------------------|----|----|----|----|----|----|-----|---|-------|---|--|
| <p>Vibration Test</p>  <p>Key X frequency, Hz Y power spectral density, $(m/s^2)^2/Hz$ 1 standard random test profile 2 additional profile in case of $f_n < 30$ Hz</p> | <p>No physical damage of housings and contacts, no derogation of function; the connection may not open during the test.</p> <p>Test VII Commercial vehicle, sprung masses, Table 12</p> <p style="text-align: center;">Table 12 — Values for PSD and frequency</p> <table border="1" data-bbox="557 1209 1044 1457"> <thead> <tr> <th>Frequency Hz</th> <th>PSD $(m/s^2)^2/Hz$</th> </tr> </thead> <tbody> <tr> <td>10</td> <td>18</td> </tr> <tr> <td>20</td> <td>36</td> </tr> <tr> <td>30</td> <td>36</td> </tr> <tr> <td>180</td> <td>1</td> </tr> <tr> <td>2 000</td> <td>1</td> </tr> </tbody> </table> <p>NOTE r.m.s. acceleration value = 57,9 m/s^2.</p> | Frequency Hz | PSD $(m/s^2)^2/Hz$ | 10 | 18 | 20 | 36 | 30 | 36 | 180 | 1 | 2 000 | 1 | <p>Acc. To ISO16750-3:2012, 4.1.2.7</p> <p>(Acceleration 57.9 m/s^2 (5g))</p> |
| Frequency Hz | PSD $(m/s^2)^2/Hz$ | | | | | | | | | | | | | |
| 10 | 18 | | | | | | | | | | | | | |
| 20 | 36 | | | | | | | | | | | | | |
| 30 | 36 | | | | | | | | | | | | | |
| 180 | 1 | | | | | | | | | | | | | |
| 2 000 | 1 | | | | | | | | | | | | | |
| <p>Mechanical shock</p>  | <p>Operation mode not in function</p> <p>Level of sharpness level 2</p> <p>Acceleration 500 m/s^2 (50g)</p> <p>Pulse form half-sinusoidal</p> <p>Pulse duration 6 ms</p> <p>Number of axes 3 axis (X, Y, Z)</p> <p>Shocks per axis 10 shocks (10 per direction)</p> <p>Total number of shocks 30 shocks</p> | <p>Acc. to ISO 16750-1, 4.2.2.2</p> <p>(10 successive shocks in 3 axis X, Y and Z is 30 shocks)</p> | | | | | | | | | | | | |

| ELECTRICAL INSPECTIONS | | |
|----------------------------------|---|--|
| Functional Test | <p>Measure the 4,4kOhm Coding-Resistor, R5</p> <p>Measure the resistance of the signal pins to the related 12pos header pins.</p> <p>Check the PCB socket contacts for wear Measure the three temperature sensors and validate versus actual charge inlet temperature</p> <p>Drive actuator in lock and unlock position as per drawing</p> <p>Measure contact resistance for all power contact terminals (AC, PE, and DC)</p> | As per customer drawing |
| Temperature Shock | <p>The product requirements shall be maintained during the test.</p> <p>T_{min} - 40°C, T_{max} 85°C Dwell Time - 45min each, 144 cycles</p> | <p>Acc. to IEC 60068-2-2 (Vibration)</p> <p>Acc. to IEC 60068-2-14 (Environment)</p> |
| Insulation Resistance | R _{iso} > 200MΩ at 1000V DC | Acc. to ISO 60512-3-1 |
| Temperature Rise | Temperature Rise with HPC (High power charging) cooling system Supplied current 500A to inlet, Monitoring T-rise, terminal temp. 90°C max. | - |
| ENVIRONMENTAL INSPECTIONS | | |
| Aging in Dry Heat | The product requirements shall be maintained during the test. | <p>Acc. To IEC 60068-2-2</p> <p>Temp 85°C Test Duration - 120 h</p> |
| Humidity | <p>The product requirements shall be maintained during the test.</p> <p>The test is concluded with functional test in normal climate.</p> | <p>Acc. to IEC 60068-2-78</p> <p>Temp 65°C 93% humidity 100h</p> |

| | | |
|----------------------|--|--|
| Degree of Protection | Grade | Acc. To below specs |
| | Dust (with flap closed) | ISO 20653 – High velocity water |
| | - IP5KX | |
| | - IP6KX | ISO 20654 – Strong high velocity water |
| | Water (with flap removed) | ISO 20656 – High pressure/steam-jet cleaning |
| | - IPX5 | |
| | - IPX6 | |
| | - IPX7 | ISO 20655 – Temporary Immersion |
| | - IPX9K | ISO 20657 – Dust protection |
| | 1) No medium must penetrate in quantities, which do not impair performance and study (possible use of water finding paste and visual inspection) | ISO 20659 – Dust Tight |

Table 5

4. TEMPERATURE RISE CURVES:

4.1. 500A T-Rise curve

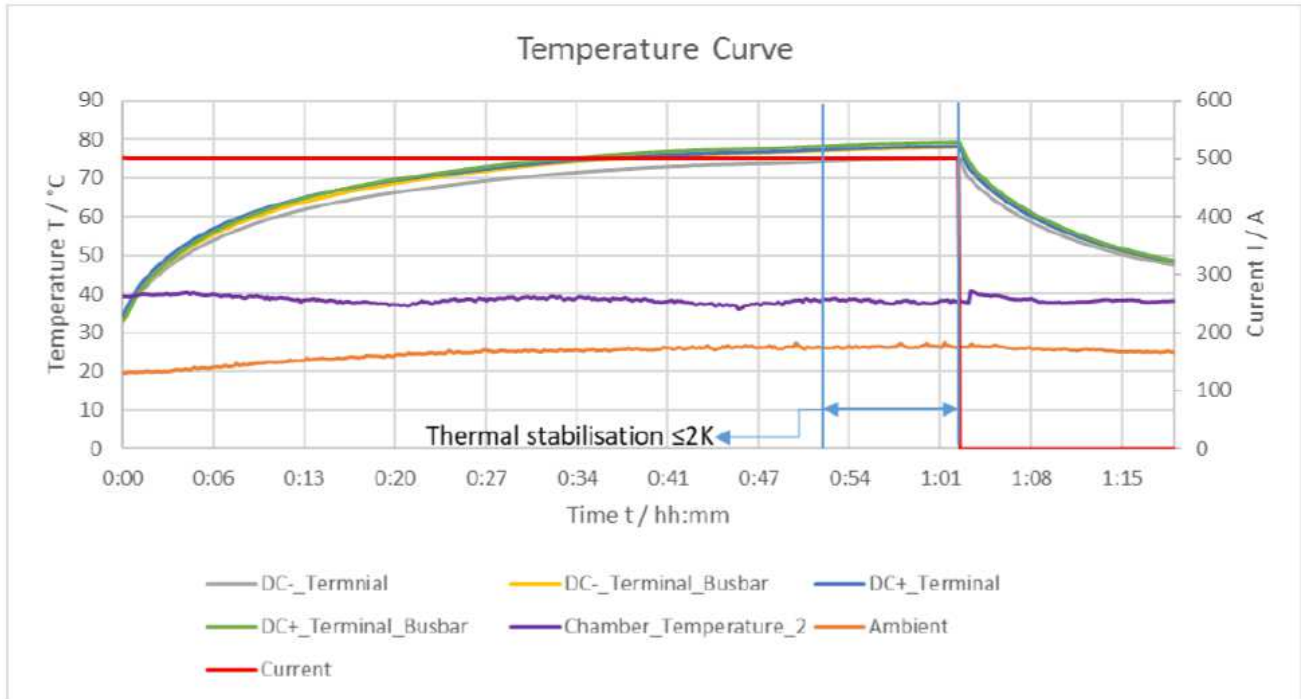

Figure 4

4.2. 600A T-Rise curve

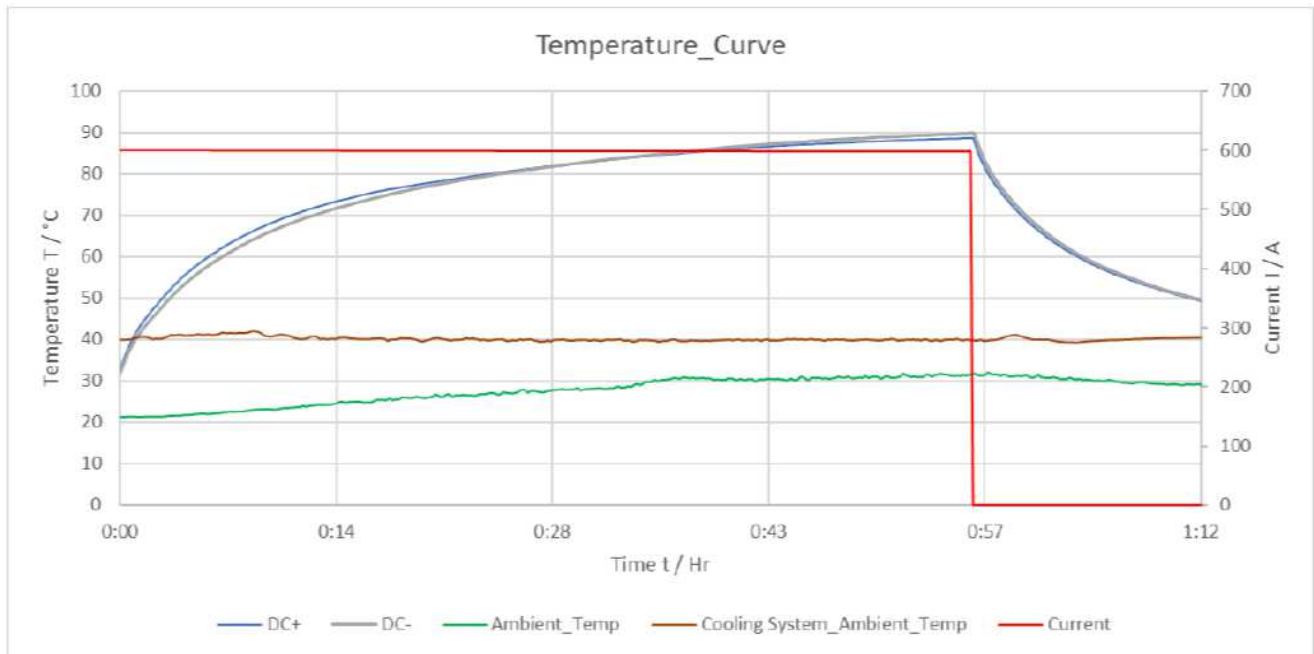

Figure 5

4.3. 700A T-Rise curve

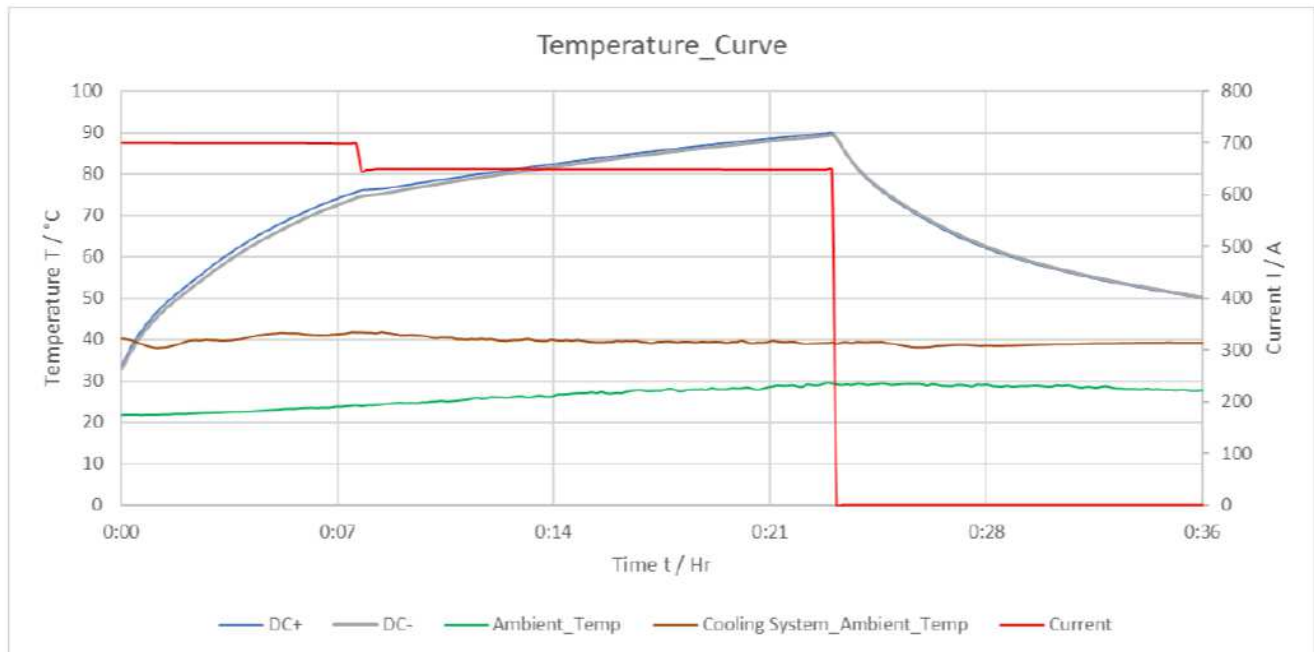

Figure 6

| <u>LTR</u> | <u>REVISION RECORD</u> | <u>DWN</u> | <u>APVD</u> | <u>DATE</u> |
|------------|------------------------|------------|-------------|-------------------|
| A | INITIAL DOCUMENT | SUPRIYA S | KASHYAP P B | 29 SEPTEMBER 2023 |
| | | | | |

| | | | |
|------------------------|--|----------|-----------|
| DWN SUPRIYA S | TE CONNECTIVITY GERMANY GMBH AMPÈRESTRASSE 12-14 D-64625 BENSHEIM GERMANY | | |
| CHK AMRUTHA RAO C H | | | |
| APVD KASHYAP P B | NO 108-94867 | REV A | LOC AI |
| TITLE | PRODUCT SPECIFICATION VEHICLE CHARGE INLET TYPE CCS 1-120MM2 | | |