UAES 65W ECU PLUG ASSEMBLY
MCP 1.5K (15PCS) + MQS 064(50PCS)

Contents/目录

1	GENERAL	2
1	综述	2
1.1	Purpose.....	2
1.1	目的.....	2
1.2	Product Drawing.....	2
1.2	产品图纸.....	2
1.3	Product Specification.....	2
1.3	产品规范.....	2
2	PRODUCT DESCRIPTION	2
2	产品说明	2
2.1	Delivery condition.....	3
2.1	产品交付状态.....	3
2.2	Connector.....	4
2.2	连接器.....	4
2.3	Contact systems.....	5
2.3	端子系列.....	5
3	APPLICATOIN DESCRIPTION	6
3	应用说明	6
3.1	Loading housing with contacts.....	6
3.1	端子的安装.....	6
3.2	Secondary locking device.....	8
3.2	二次锁.....	8
3.2.1	Locking of the secondary locking device.....	8
3.2.1	二次锁的安装.....	8
3.2.2	Unlocking of the secondary locking device.....	9
3.2.2	二次锁的解锁.....	9
3.3	Assemble of cover.....	10
3.3	上盖的安装.....	10
3.4	Extraction of the contacts.....	11
3.4	端子的退出.....	11
3.5	Install connector to Header.....	12
3.5	安装连接器到公端上.....	12
3.6	Mating & Un-mating of the connector.....	15
3.6	连接器的对配&分离.....	15
3.6.1	Connector mating.....	15
3.6.1	连接器的对配.....	15
3.6.2	Connector Un-mating.....	17
3.6.2	连接器的分离.....	17

1. GENERAL

1. 综述

1.1 Purpose

1.1 目的

This specification includes the guidelines for the application and the mounting of the 65W connector and its accessories.

本规范为 65 位连接器及其相关配件的应用和装配提供参考。

1.2 Product Drawing

1.2 产品图纸

Dimensions, materials and surfaces see valid product drawings.

产品尺寸、材料和表面可参看有效的产品图纸。

C-2299987 Customer drawing for Housing assembly.

C-2299987 塑胶本体组装客户图

C-2299988 Customer drawing for Cover assembly.

C-2299988 盖子组装客户图

C-114-101045 Customer drawing for Interface.

C-114-101045 对配界面客户图

1.3 Product Specification

1.3 产品规范

This application specification is valid for the products specified in product specification 108-101460.

This application specification provides a description of the electrical and mechanical properties of this connector. Furthermore, the product and application specifications of the contact systems have to be observed.

本应用规范仅适用于产品规范（108-101460）所涉及的相关产品。本应用规范为此连接器提供了电气和机械性能的描述。此外，还需要遵循所适用端子的产品和应用规范。

2. PRODUCT DESCRIPTION

2. 产品说明

2.1 Delivery condition

2.1 产品交付状态

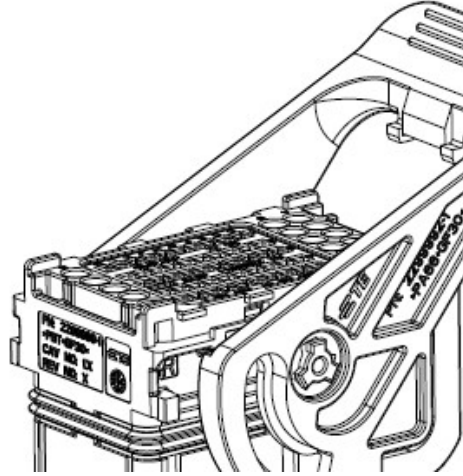
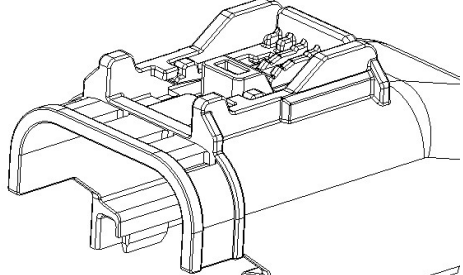
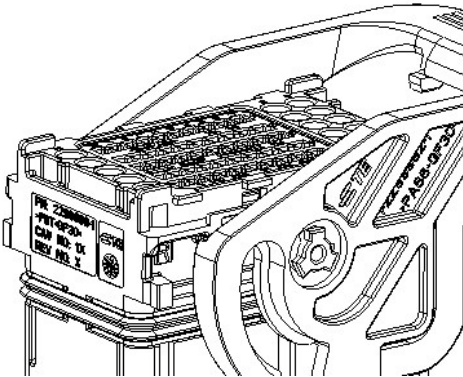
Product Description 产品描述	PART NUMBER 产品料号	Picture 图片
<p>65W HOUSING ASSEMBLY (180 Degree cable exist) 65 位塑胶本体组装品 (180 度出线)</p>	<p>2299987-1 2299987-2 2299987-3 2299987-4</p>	
<p>65W COVER ASSEMBLY (180 Degree cable exist) 65 位盖子组装品 (180 度出线)</p>	<p>2299988-1 2299988-2</p>	
<p>65W HOUSING ASSEMBLY (45 Degree cable exist) 65 位塑胶本体组装品 (45 度出线)</p>	<p>1-2299987-1 1-2299987-2 1-2299987-3 1-2299987-4</p>	

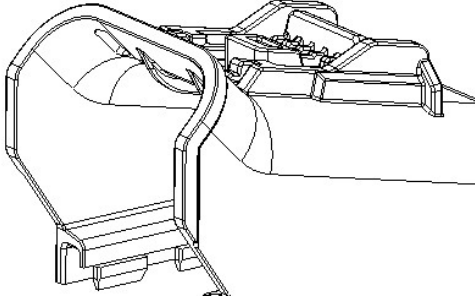
65W COVER ASSEMBLY (45 Degree cable exist) 65 位盖子组装品 (45 度出线)	1-2299988-1 1-2299988-2	
--	----------------------------	--

2.2 Connector

2.2 连接器

The components of 65W connector (180 degree as sample) as shown in Fig.1
 65 位的组装零件（以 180 度出线方向的产品为例）见图片 1.

- 1 ----- Front cover (前盖子)
- 2 ----- 2nd lock (端子 2 次锁)
- 3 ----- Interface seal (O 型密封圈)
- 4 ----- Base housing (塑胶本体)
- 5 ----- Family seal (密封垫)
- 6 ----- Seal cover (密封垫盖子)
- 7 ----- Lever (扳手)
- 8 ----- Cover (上盖)
- 9 ----- CPA (连接器 2 次锁)

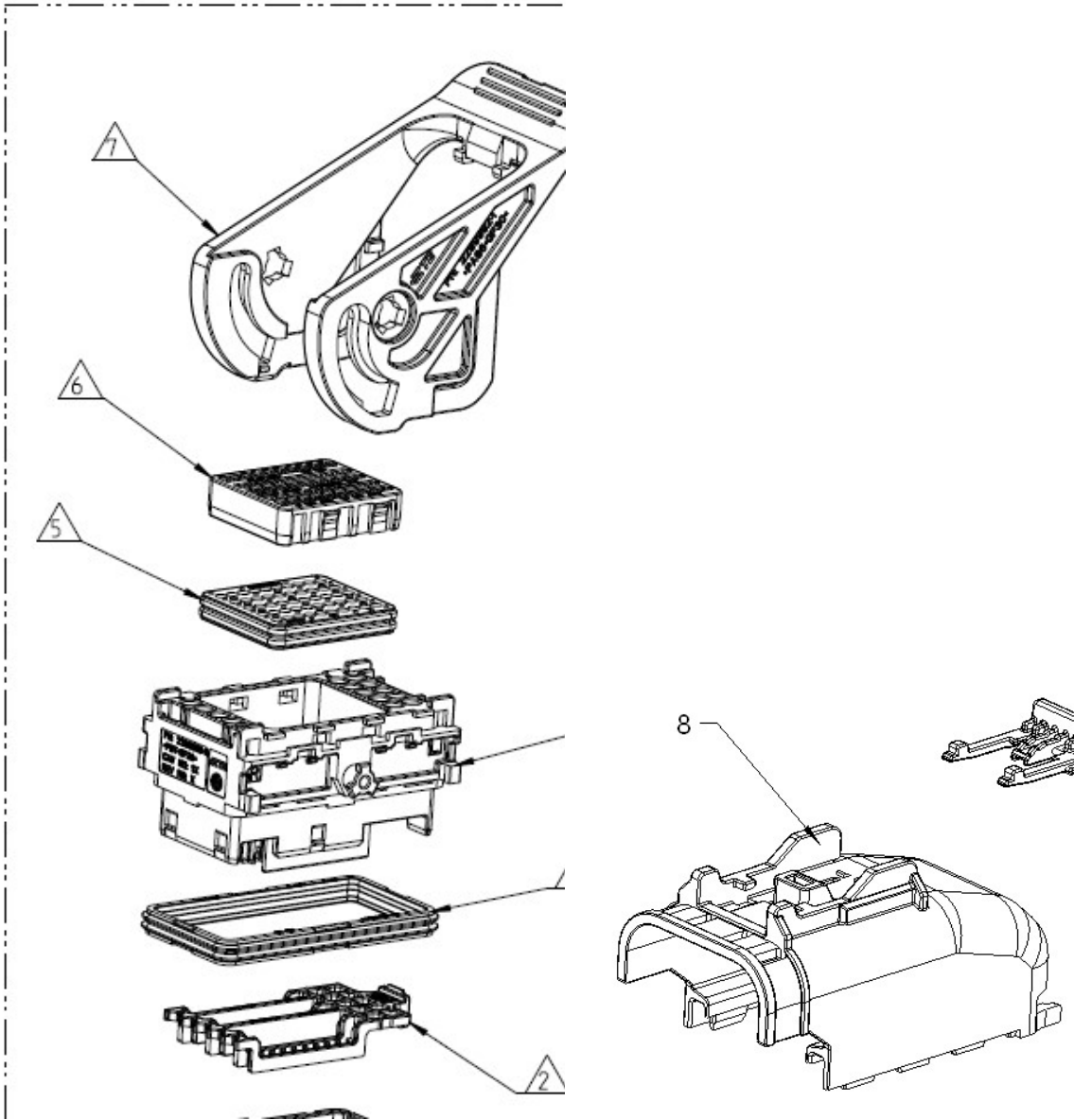

Fig. 1 (图 1)

2.3 Contact systems

2.3 端子系列

Suitable terminals and attached parts see following terminal information table, this 65W connector used 50pcs MQS 064 clear body terminal and 15pcs MCP 1.5K terminal. Any other application wire size and finish spec not shown in this table, please contact TE engineering team for checking. 可适用的端子以及附件信息（盲堵，密封塞）请参考以下表格，65位连接器用了50根MQS 064的端子和15根MCP 1.5的端子。没有列在表格里信息，比如线径，端子电镀等，请跟TE工程团队确认。

TERMINAL INFORMATION TABLE					
TREMINAL INFORMATION	TE P/N	FINISH	WIRE SIZE (MM2)	WIRE SIZE DIAMETER	SWS
MQS 064 CLEAR BODY	968221-1	PRE-TIN	0.5~0.75	Ø1.4~Ø1.9	N/A
MCP 1.5K SWS	1241380-1	PRE-TIN	0.5~1.0	Ø1.4~Ø1.9	963530-
				Ø1.4~Ø1.9	964972-

Performance information about the MQS 064 and MCP 1.5K contact systems and their applications are provided by the related product and application specifications:

关于MQS 064 和MCP 1.5K 端子的性能及应用方面的信息，请参考下列相关的产品规范及应用规范:

MQS 064:

Customer drawing (客户图纸) : C-1355900

Product specification (产品规范) : 108-18030

Application specification (应用规范) : 114-18021

MCP 1.5K:

Customer drawing (客户图纸) : C-1241436

Product specification (产品规范) : 108-18716

Application specification (应用规范) : 114-18386

3. APPLICATOIN DESCRIPTION

3. 应用说明

3.1 Loading housing with contacts

3.1 端子的安装

Contacts can only be inserted if the secondary lock is in the pre-lock position, see Fig.2

只有在二次锁处于预锁位置的情况下才可以进行端子的安装，参见图2

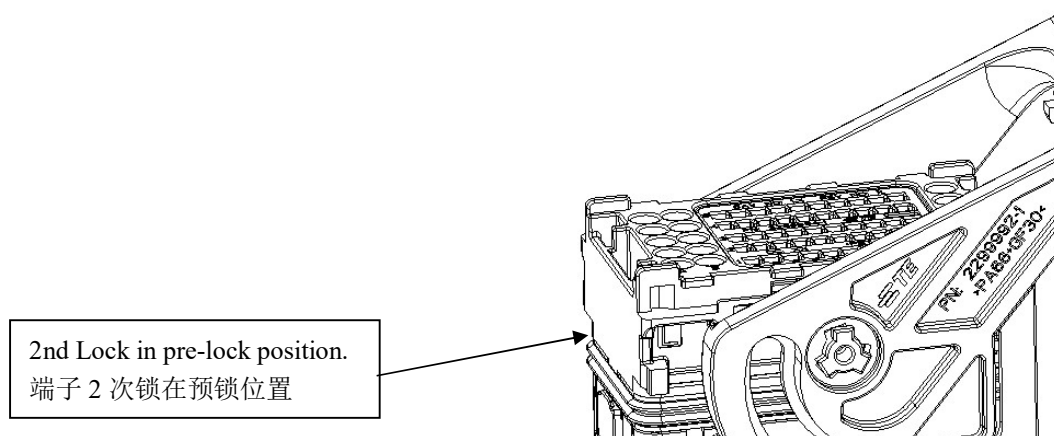

Fig.2 (图2)

Pay attention to the correct orientations of contacts acc. to Fig. 3.4.5

需要注意端子在安装过程中应处于图3图4图5所示的正确安装方向。

MCP 1.5K terminals insertion direction:

MCP 1.5K 端子插入方向:

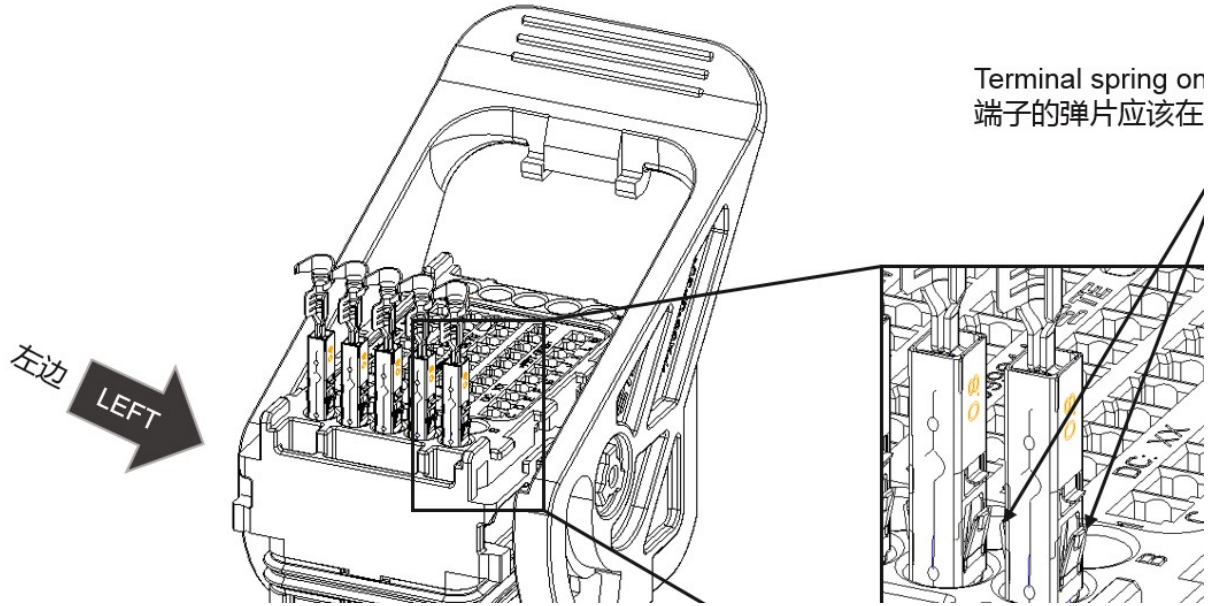

Fig. 3 (图3)

MQS 064 terminals insertion direction:

MQS 064 端子插入方向:

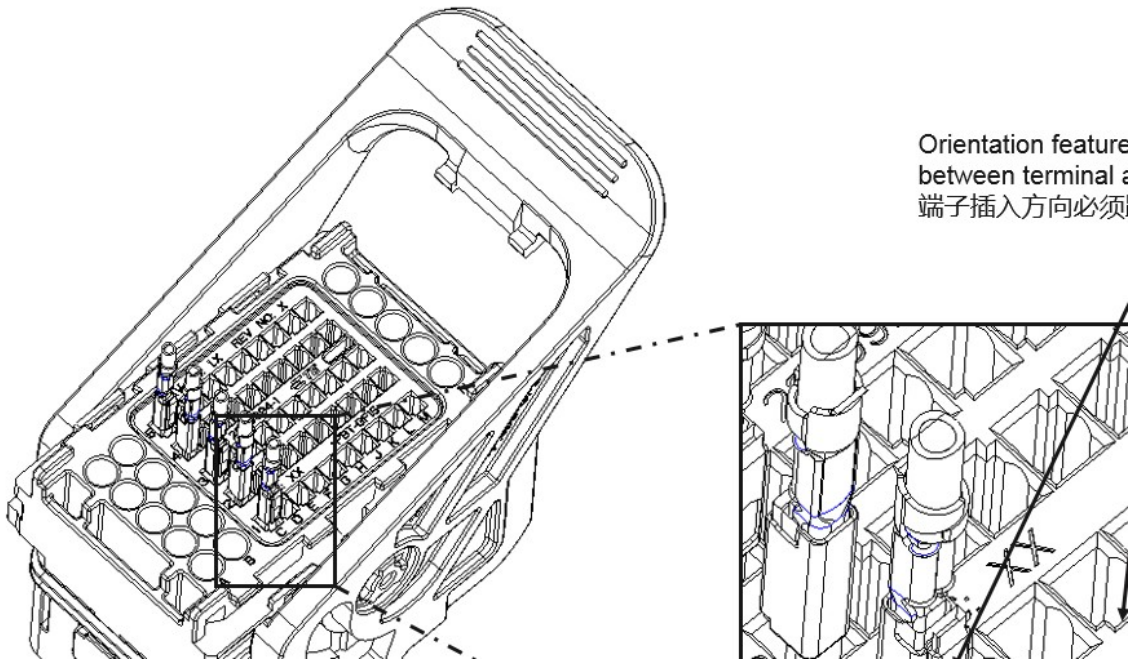

Fig. 4 (图4)

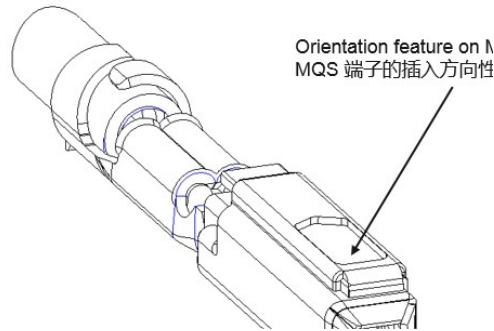

Fig. 5 (图5)

With correct install method, the locking is signaled by a stop (contacts are located in the cavities completely) and a metallic “click” noise.

如果安装方法正确，端子会在一个明显的锁紧位置停止（端子完全插入孔位的内部），并会听到一次“咔”的声音。

After contacts have been rightly loaded, the secondary lock should be moved to the end-locked position, see Fig.6

正确安装完端子后，需将二次锁移至终锁位置，参见图6。

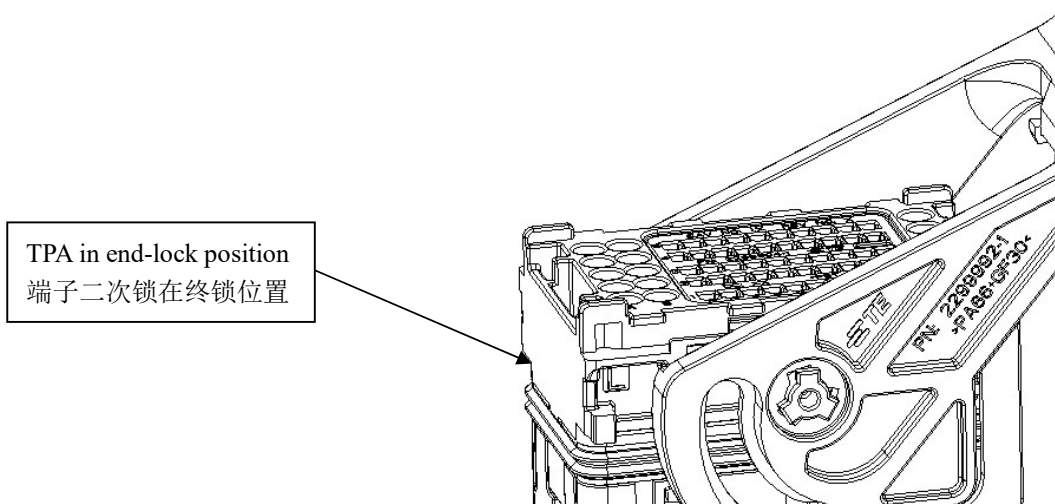

Fig. 6 (图6)

3.2 Secondary locking device

3.2 二次锁

3.2.1 Locking of the secondary locking device

3.2.1 二次锁的安装

The connector described in this specification is equipped with a pre-assembled secondary locking device. The secondary locking device provides an additional retaining force for the terminals if the primary lock fails. Delivery state is the pre-locked position. Only in this position the contacts can be

loaded.

本规范中所描述的连接器上已预先安装好一个二次锁紧装置。此二次锁用于在一次锁失效时对端子提供额外的保持力。其出厂状态是处于预锁紧位置上的。只有在此预锁紧位置上时，端子才可以正确被安装。

After all terminals have been inserted completed, push the secondary locking device into the final locked position (see figure 7).

所有端子安装完成之后，按压二次锁将二次锁移动到最终的锁紧位置（参见图7）。

There is a clear “click” noise can be heard during the locking procedure.

到达锁紧位置过程中，能听到一声“咔”的声音。

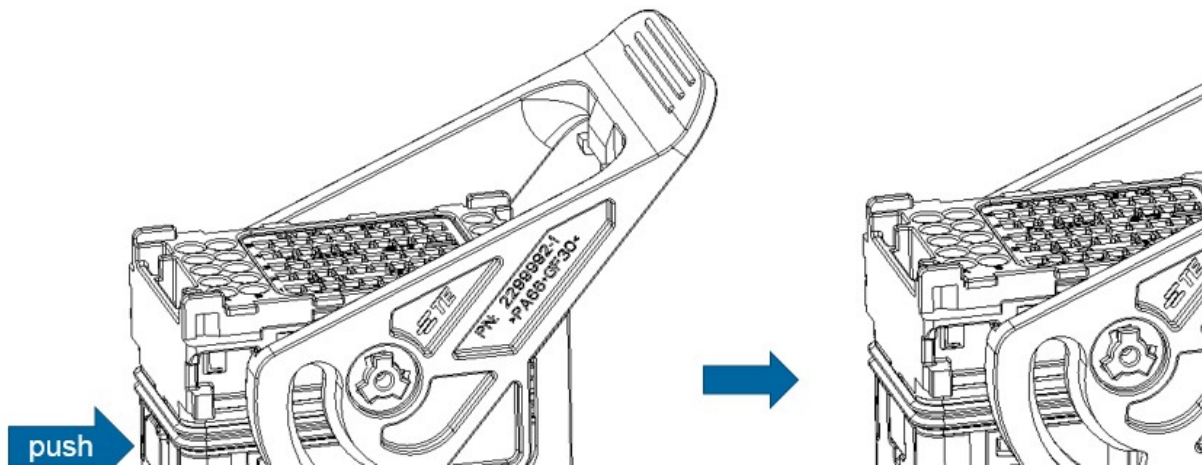

Fig. 7 (图7)

Note:

注意:

The secondary locking device does not stringently detect the correct position of the terminal in the cavity. Correct contact location must be assured before the secondary locking device is activated.

二次锁不能用于检测端子是否安装到正确位置。必须保证二次锁安装到终锁位置之前端子已经都处在正确位置。

Only if both secondary locking devices (receptacle and tab side) are in the closed position can the connector be mated (Poka-Yoke-Feature).

只有当二次锁（母端连接器和公端连接器）都处于终锁位置时，两端连接器才能对配（防错特征）

3.2.2 Unlocking of the secondary locking device

3.2.2 二次锁的解锁

A suitable screwdriver has to be inserted into the provided recess (see figures 8) to unlock the secondary locking device. With a small force, the locking device can be moved into the pre-locked position.

将合适大小的螺丝刀插入如图8所示的凹槽处，用一个较小的力即可将二次锁移动到预锁位置。

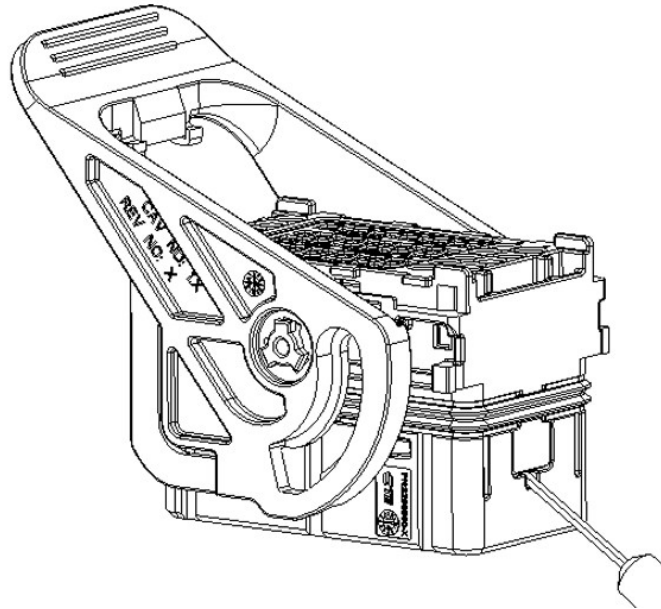

Fig. 8 (图8)

3.3 Assemble of cover

3.3 上盖的安装

Before assembling the cover, the lever must be in pre-lock status. Assemble the cover from up to down as picture (see figures 9) shown position, and then push the cover from back to front till the lockers of cover locked with base housing. This operation will be with a “click”, it means the cover has been assembled success.

在安装上盖之前，需要保证杠杆在预锁状态。在图示（图9）位置从上往下安装上盖，然后从前往后推动上盖，直到上盖两侧的卡扣锁住塑胶本体上，此时会听到清脆的“咔”声，说明上盖安装到位。

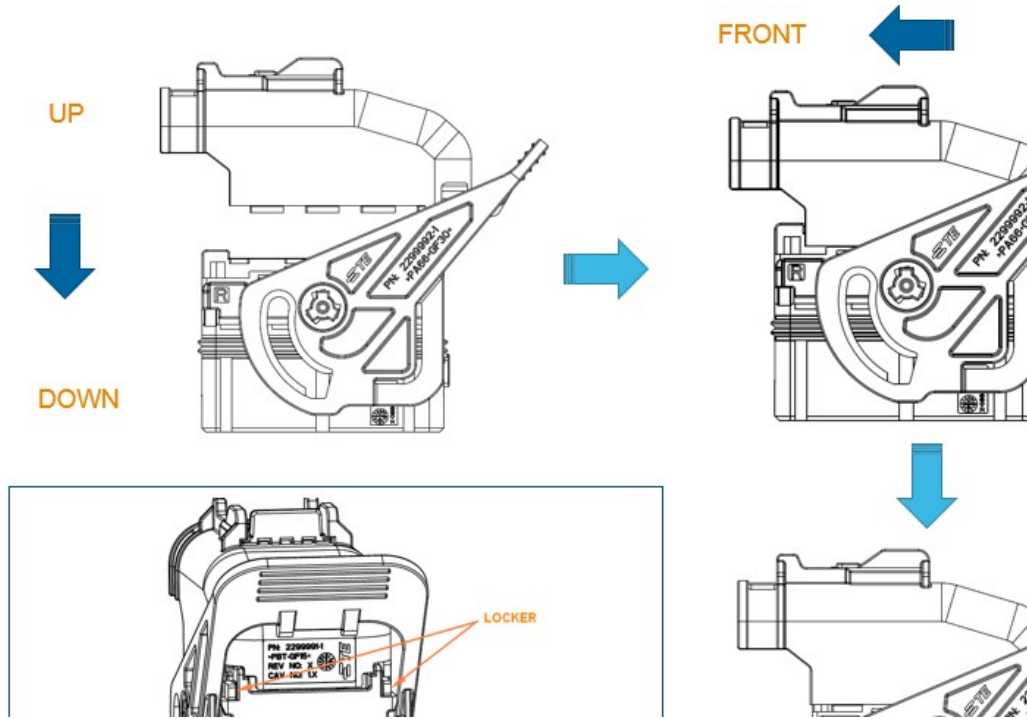

Fig. 9 (图9)

Note:

注意:

1. Before assembling the cover, all the wire assembled into 65way housing assembly must be bound shipshape with packaging tape so as not to be nipped and damaged by cover and housing in cover-assembling process. Please see fig 10 for the right bound way.

1. 请不要在解锁端子之前拉导线，在解锁时可用另一只手将导线往拔出的相反方向轻轻往里推，这样解锁过程会更加顺利。

2. Before assembling the cover, All the wires must be tied regularly shown as below picture, and make sure the width of tied wires is less than 20mm, less than 18mm is the best, so as not to damage the wires when assemble cover.

2. 装上盖前线要将线捆起来，并且线不能捆的太松，如下图所示，捆后的线束宽度不能大于20mm，最好18mm，以免装上盖时，将捆的松散的线损坏。

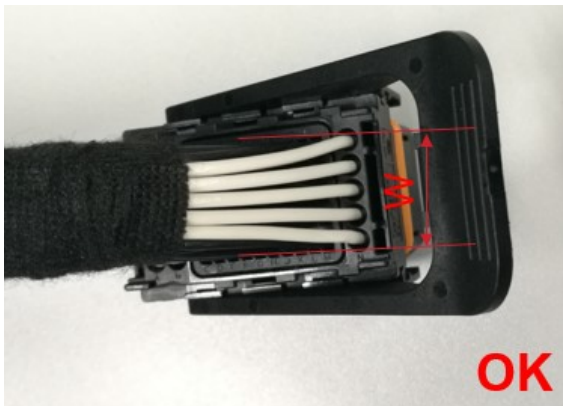

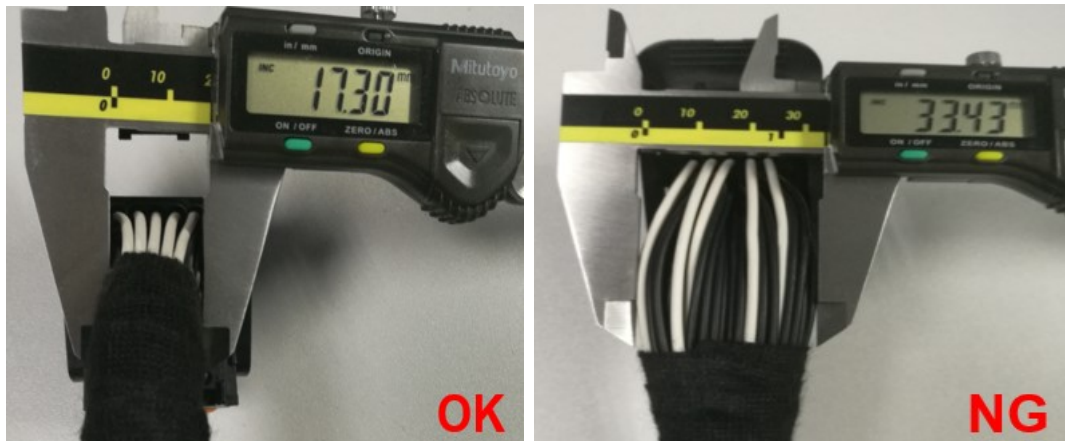

3.4 Extraction of the contacts

3.4 端子的退出

The secondary locking device must be in the pre-locked position before extracting contacts. TE provides a sufficient unlocking and extracting tool (TE P/N FOR MQS: 2-1579008-3, TE PN FOR MCP: 2-1579008-7), see Fig 10.

在退出端子之前，必须保证二次锁已经处于预锁位置。TE 为此提供了一系列的解锁和拔出工具(MQS 端子 TE 料号：2-1579008-3，MCP 料号 TE 料号 2-1579008-7),参见图 10。

The blades of the tool have to be inserted from the connection side into the 2 slots of the according contact cavity until the stop (see figure 11); the contact will be unlocked thereby. The tool remains in that position and the contact can be taken out now by pulling at the cable.

首先将工具的夹片从连接侧插入端子孔位所对应的两个槽内直至停止位置（参见图 11），在此位置上端子将被解锁。将工具保持在此位置，之后可通过向外拉导线将其拔出。

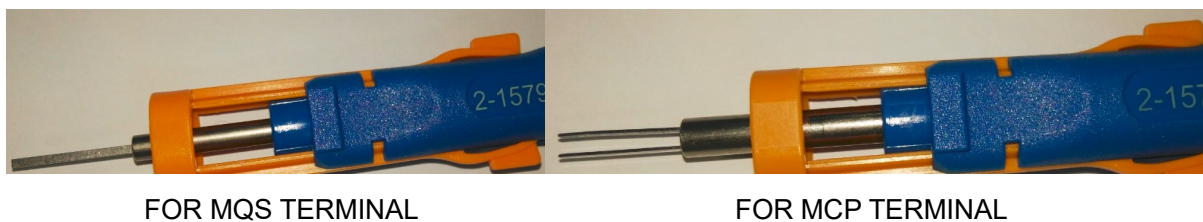

Fig 10: contact extraction tool

图 10: 退 pin 器



FOR MCP TERMINAL

FOR MQS TERMINAL

Fig. 11 (图11)

Note:**注意:**

Do not pull the cable before unlocking the contact; pressing the cable gently against the cable outlet direction by another hand, the unlocking procedure will be facilitated.

请不要在解锁端子之前拉导线，在解锁时可用另一只手将导线往拔出的相反方向轻轻往里推，这样解锁过程会更加顺利。

3.5 Wire pull out direction of connectors**3.5 连接器的出线方向**

65W connector has two types, one is 180 degree cable pull out, and the other is 45 degree up, mated interface header is two pockets for 130W. So normally, there are two application for connectors installation, one is back to back, and the other is same direction of two connectors.

65位产品有两种出线方式，一种是水平出线，另一种是斜45度向上出线。对配公端是由两个框口组成的130位产品，所以通常情况下，连接器有两种出线方向，一种是“背靠背”出线，另一种是两个连接器同方向出线。

3.5.1 Two connectors back to back**3.5.1 连接器“背靠背”出线****a) Two 180 degree connectors**

两个180度出线的连接器组合

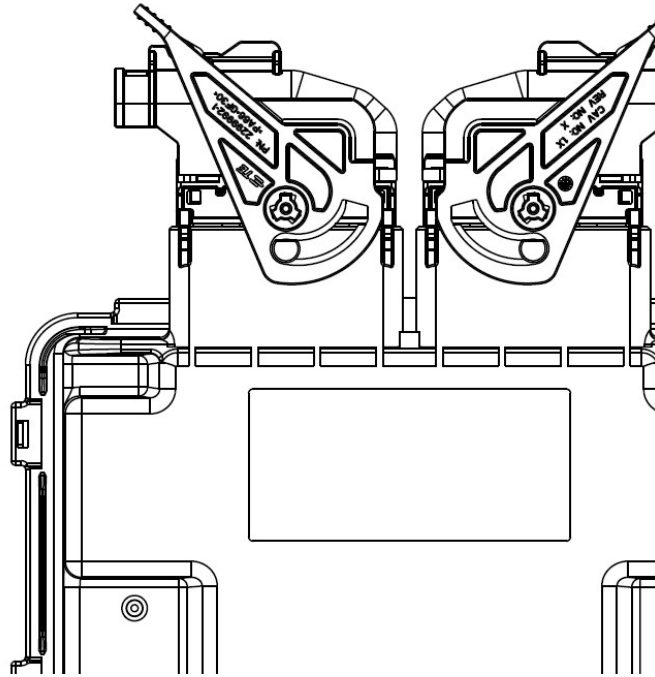

b) One 180 degree connector and one 45 degree connector

Request: Mate 45 degree firstly, and then mate 180 degree one. Un-mate 180 degree firstly, and then un-mate 45 degree one.

一个180度连接器和一个45度连接器组合

要求：在安装的时候，先安装45度连接器，然后再安装180度的连接器。在拔出的时候，先拔出180度的连接器，再拔出45度的连接器。

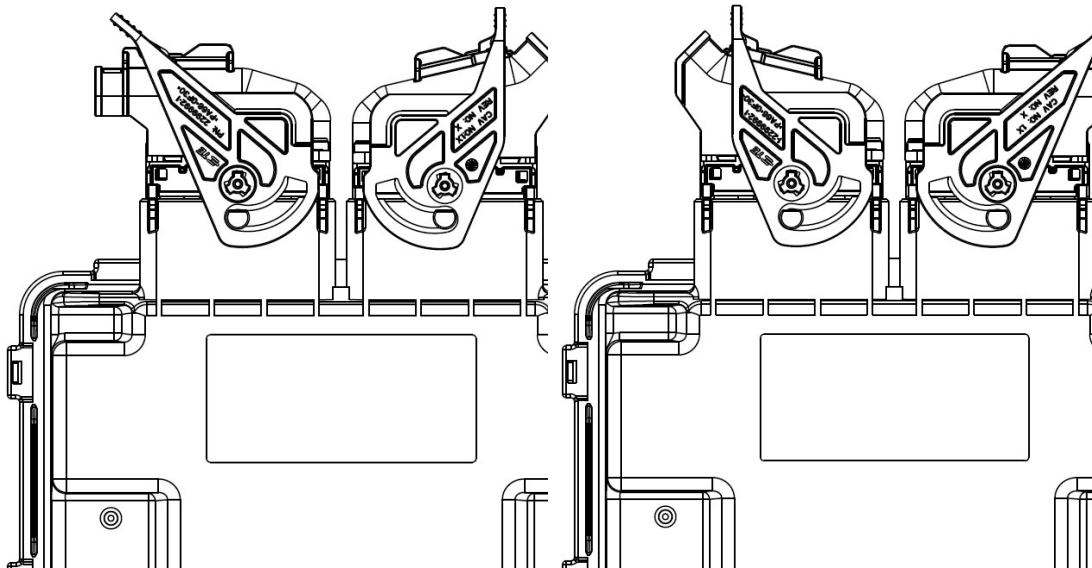

c) Two 45 degree connectors (not allowed because lever operation space limited)

两个45度连接器组合（不能实现两个45度出线的连接器背靠背出线，因为操作空间上的限制）

3.5.2 Two connectors same direction

3.5.2 连接器同方向出线

a) **Two 180 degree connectors (not allowed because lever operation space limited)**

两个**180度**出线连接器（不能实现两个**180度**出线的连接器同向出线，因为空间限制）

b) One 180 degree connector and one 45 degree connector

Request: the back one must be 45 degree. Mate 180 degree firstly, and then mate 45 degree one. Un-mate 45 degree firstly, and then un-mate 180 degree one.

一个**180度**连接器和一个**45度**连接器的组合

要求：背后的一个连接器必须是**45度**的，连接器安装时，先安装**180度**的连接器，然后在安装**45度**的连接器，在拔出时，先拔出**45度**的连接器，再拔出**180度**的连接器。

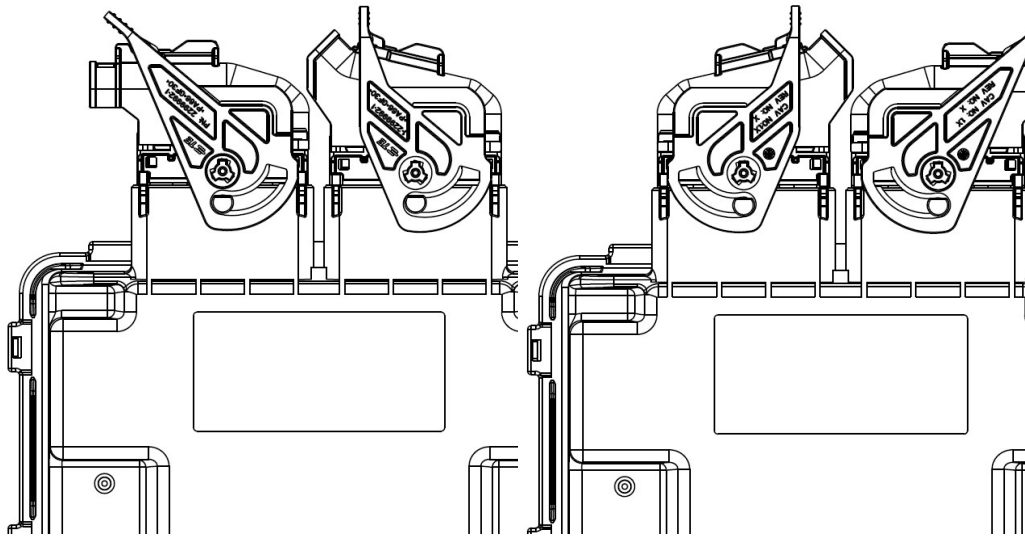

c) Two 45 degree connectors

Request: mate front one firstly. And then mate the other one. Un-mate the back one firstly, and then un-mate the other one.

两个**45度**出线的连接器组合

要求：安装连接器的时候，先安装靠前的一个，在安装靠后的一个，在拔出的时候，先拔出靠后的一个，再拔出靠前的一个。

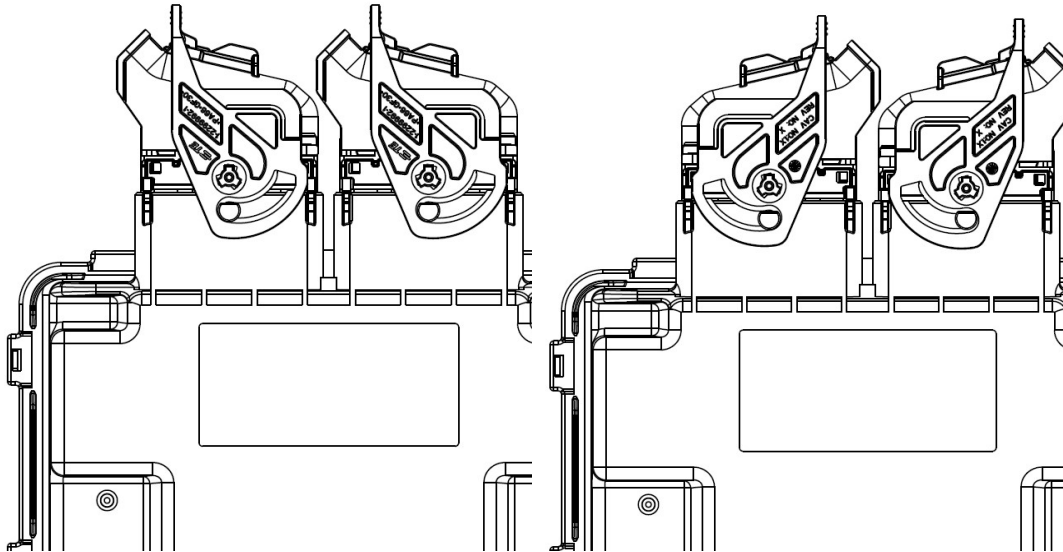

3.6 Mating & Un-mating of the connector

3.6 连接器的对配&分离

Note:

注意:

Before installation, it is necessary to load the connector with contacts.

在安装连接器之前，需先确认连接器上已经安装了端子。

Please make sure the axial seal is in right position before install the connector onto a mounting wall.

在装配前，请确认轴向密封圈处于正确位置！

Delivery state of the secondary lock is in the pre-locked position, only in end-locked position can the tab connector be rightly mated with receptacle connector, please make sure the secondary lock has been moved to the end-lock position before installation.

二次锁在出厂状态下是处于预锁紧位置的，其只有在锁止位置时公端连接器才能正确与母端连接器对配，请在安装前确认连接器的二次锁已被移动到终锁位置。

Before installation, it is necessary to confirm that the coding of connector is matched with interface.

在安装连接器前，需要先确认连接器是否跟对配端匹配。

3.6.1 Connector mating

3.6.1 连接器的对配

The connectors described in this specification are equipped with three protection features.

本规范所描述的连接器的三个防错结构。

- ◆ Coding and polarization (coding防错)

Correct polarization and coding must be chosen for the counterpart or the customer

drawing.

选择对配端时需保证coding正确。

- ◆ **Position control of the secondary locking device (二次锁位置防错)**
If the secondary locking device is not locked position, the connectors can't be mated with normal force.
如果二次锁未处于终锁位置，连接器无法以正常大小力对配。
Correct position of the contacts must be controlled, therefore only if the secondary locking device is locked position can mating be completed
必须管控端子是否装到位，只有当二次锁处于终锁位置时连接器才能完全对配。
- ◆ **Position control receptacle housing to counterpart(母端连接器与公端连接器相对位置防错)**
The receptacle connectors have a lever as a mating and un-mating assist, which is in the pre-locked position as delivered.
母端连接器设计有杠杆助力机构，其出货状态处于预锁位置。
The lever is retained by hooks in the pre-locked position. Without the counterpart the slide can't be actuated with normal force.
此杠杆由挂钩固持在预锁位置上，在没有对配端的情况下无法以正常大小的力拉动此拉杆。
Only after the connector is offered up to the counterpart until arms of lever be expanded, it means the lever is unlocked. And the lever can be actuated and mating completed.
只有将此连接器与其对配端对插至杠杆弹片弹开时，此杠杆才处于解锁状态，转动杠杆连接器可以完全对配。

旋转杠杆直到杠杆跟产品上盖的卡扣自动锁住，此时会有（咔）的响声，说明对配到位，然后向前推动产品二次锁，直到听到（咔）的响声，说明二次锁到终锁位置。

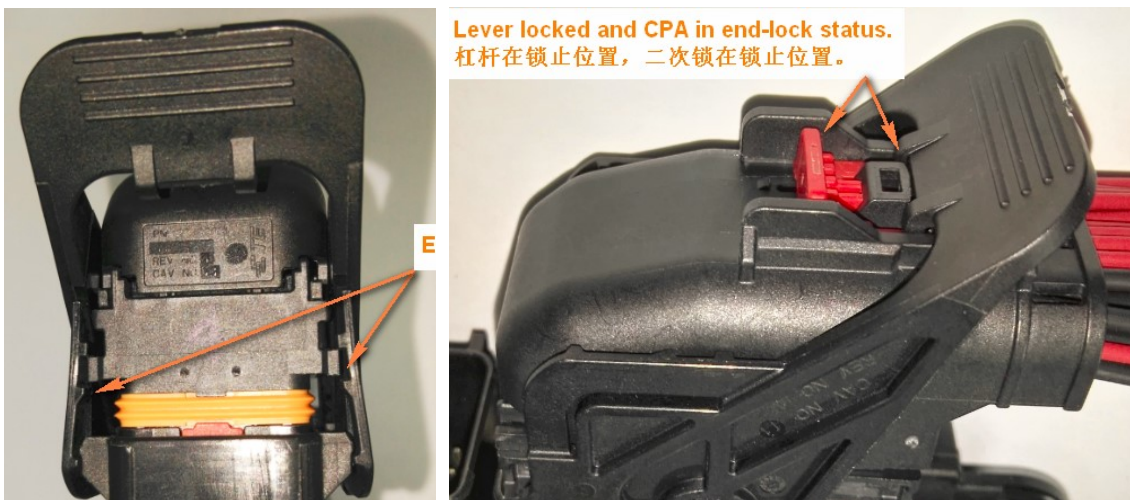

Fig.12
图12

3.6.2 Connector Un-mating

3.6.2 连接器的分离

Firstly, make the CPA to un-lock status, and then press the lock structure of cover until the lever can be rotated. Rotate lever until a mechanical stop happened with a soft “click” noise, that indicate the pre-locked position is reached, un-mated connector. When rotating lever with one hand, the other hand shall press the end of cover, shown as below.

首先，退出连接器二次锁，然后按压上盖的锁止弹片直到杠杆可以解锁，旋转杠杆当感觉到机械停止和听到柔和的“咔”的声音时，说明拉杆已到达预锁位置，拔出连机器。旋转杠杆时，需要一只手按压住上盖尾部，另外一只手旋转杠杆，如下图所示。

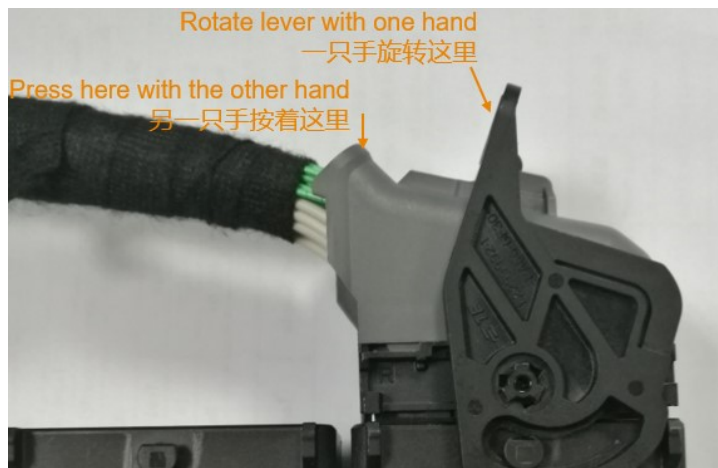

NOTES:

If the large resistance force when rotate lever, it is because a negative pressure exist between male and female connector, DON'T rotate the lever continually, sectional rotation is correct method and it will be easy to make the lever in pre-lock status. Finally un-mated the connector successful.

注意：如果转动杠杆时受到很大的阻力，这是因为产品内部有负压导致，这时不可强行旋转杠杆，需分几次停顿旋转杠杆，直到杠杆到预锁位置，拔出连接器。