



All numerical values are in metric units [with U.S. customary units in brackets]. Dimensions are in millimeters [and inches]. Unless otherwise specified, dimensions have a tolerance of ± 0.13 [± 0.005] and angles have a tolerance of $\pm 2^\circ$. Figures and illustrations are for identification only and are not drawn to scale.

1. INTRODUCTION

This specification covers the requirements for the application of Non-Concentric Twinax Pin and Socket Assemblies. These pin and socket assemblies are applied to cable. The contact assembly contains an outer shell, a two-piece dielectric, two 24 AWG signal contacts, and an inner crimp ferrule. An optional sealing boot/plug is also available. These pin and socket assemblies may be used in connector systems such as Rectangular Quadrax Connectors, ARINC* 600 Connectors, and MIL-DTL-38999 style connectors. Contact TE Connectivity Product Engineering for specific application requirements for these other product lines.

When corresponding with TE Personnel, use the terminology provided on this specification to help facilitate your inquiry for information. Basic terms and features of this product line are provided in Figure 1.

NOTE: Figures and illustrations are for identification only and are not drawn to scale.

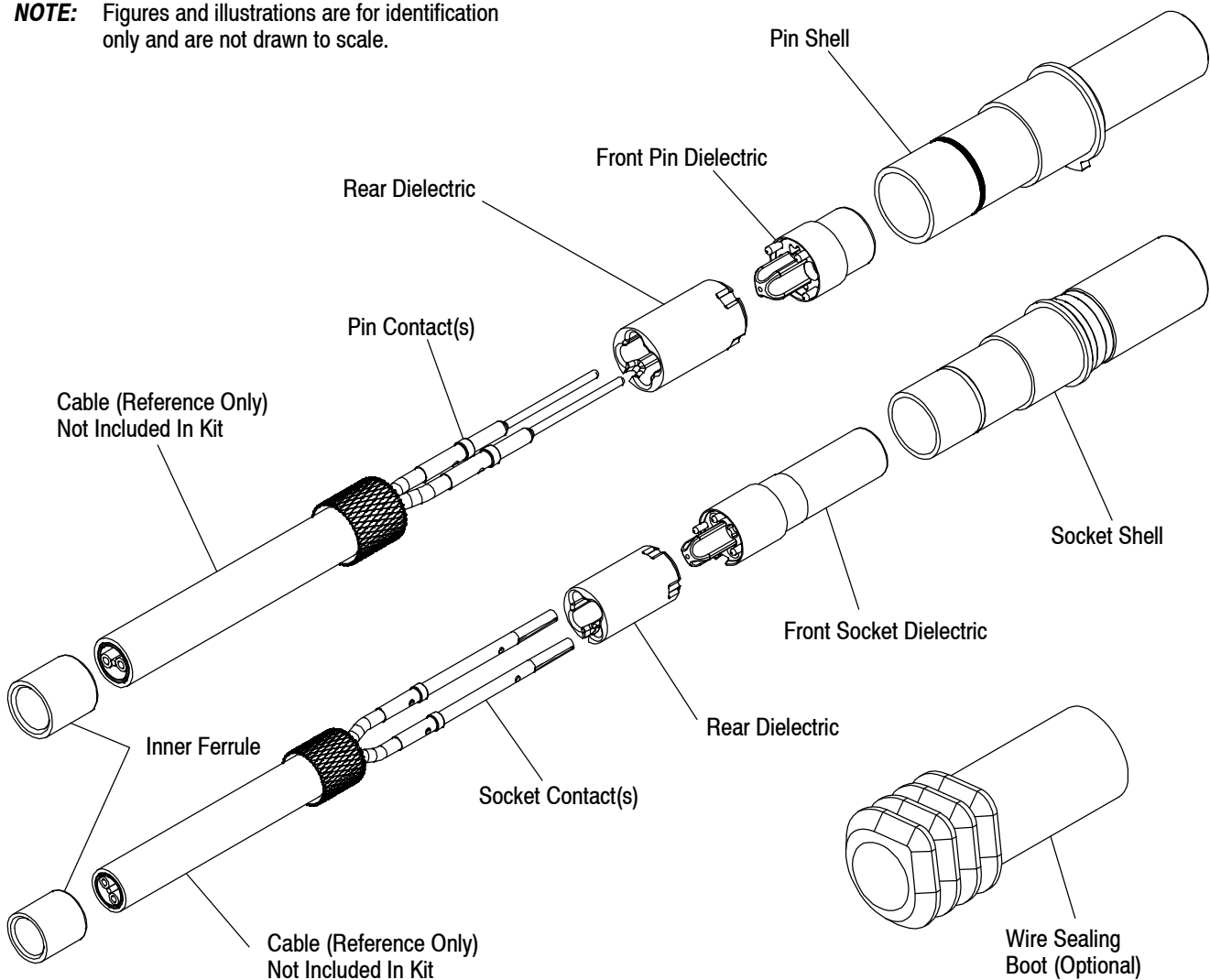

Figure 1

2. REFERENCE MATERIAL

2.1. Revision Summary

- Material changed to PTFE

2.2. Customer Assistance

Reference Base Part Number 1811865, Product Code L132, and Product Line Code 257-ARINC are representative numbers of Non-Concentric Twinax Pin and Socket Assemblies. Use of these numbers will identify the product line and expedite your inquiries through a service network established to help you obtain product and tooling information. Such information can be obtained through a local TE Representative or, after purchase, by calling the Tooling Assistance Center or the Product Information Center number at the bottom of page 1.

2.3. Drawings

Customer drawings for specific products are available from the service network. The information contained in the customer drawings takes priority if there is a conflict with this specification or with any other technical documentation supplied by TE. Contact the Product Information Center number at the bottom of page 1 if such a conflict is encountered.

2.4. Instructional Material

The following list includes available instruction sheets (408-series) that may provide assembly procedures for product, operation, maintenance and repair of tooling.

<u>Document Number</u>	<u>Document Title</u>
408-2766	Coaxial Cable Stripper Cable Kits 603995
408-7424	Checking Terminal Crimp Height or Gaging Die Closure
408-7516	Application Tooling for Screw-Machine Contacts

3. REQUIREMENTS

3.1. Safety

Do not stack product shipping containers so high that the containers buckle or deform.

3.2. Limitations

The connectors are designed to operate within a temperature range of -65° to 200°C [-85° to 392°F].

NOTE	<i>Temperature rating of the cable must be considered when determining operating temperature of the connector and cable assembly.</i>
	

3.3. Storage

A. Ultraviolet Light

Prolonged exposure to ultraviolet light may deteriorate the chemical composition of components used in the contacts or connectors.

B. Shelf Life

The contacts and connector kits should remain in the shipping containers until ready for use to prevent damage. These products should be used on a first in, first out basis to avoid storage contamination.

C. Chemical Exposure

Do not store these assemblies near any chemicals listed below, as they may cause stress corrosion cracking in the components.

Alkalies	Ammonia	Citrates	Phosphates	Citrates	Sulfur Compounds
Amines	Carbonates	Nitrites	Sulfur Nitrites		Tartrates

3.4. Cable Selection and Preparation

Special considerations must be adhered to in the cable stripping operation.

A. Selection

The pin and socket contacts will accept a wire size of 24 AWG in a 2-conductor cable configuration such as Raychem 0024T1426. Contact TE about other cable sizes and compatible contacts.

B. Preparation

1. Proper strip length is necessary to properly apply the cable to the contact. See Figure 2.



Reasonable care must be taken not to nick, scrape, or cut any conductors during the stripping operation.

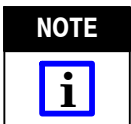

If a wire sealing boot is to be used, install the wire sealing boot onto the wire prior to stripping the wire. Minimize handling of the seal glands as it will reduce the lubricity.



To calculate cable length "L" (for a given total length), refer to the "NOTE" in Figure 2A.

2. Strip cable jacket to length indicated in Figure 2B.
3. Assemble the inner ferrule over the braid as shown in Figure 2C.
4. Comb the braid, dress over the inner ferrule, and trim the braid as shown in Figure 2D.
5. Cut the PTFE Tape (if present), foil and cable fillers to length as shown in Figure 2D.

2A

NOTE: Pin-to-Pin = $L_T - 31.70$ [1.248]
 Socket-to-Socket = $L_T - 36.62$ [1.442]
 Plug-to-Socket = $L_T - 34.16$ [1.345]

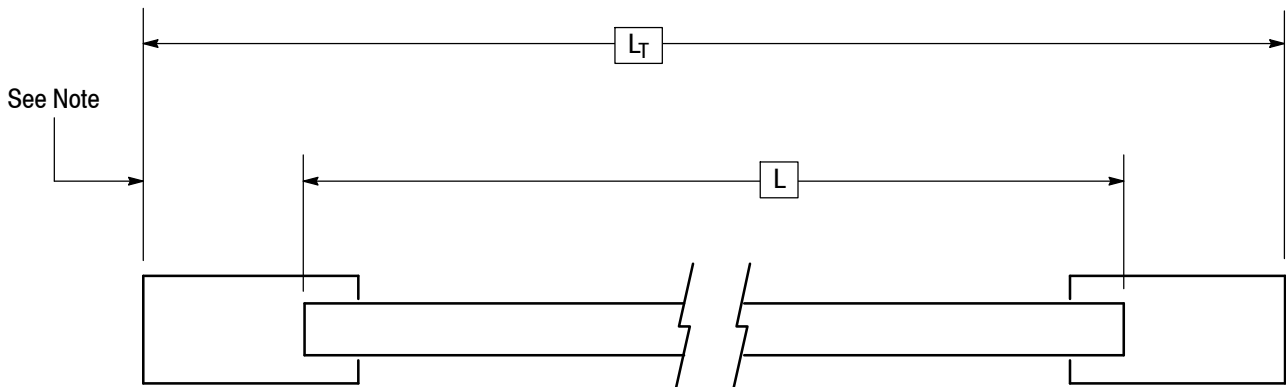
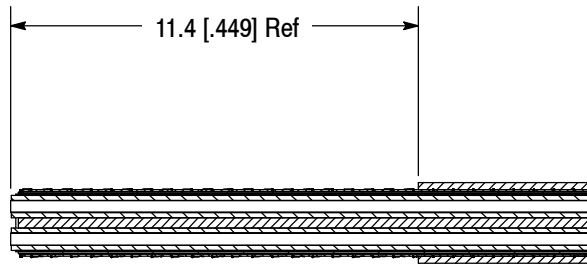
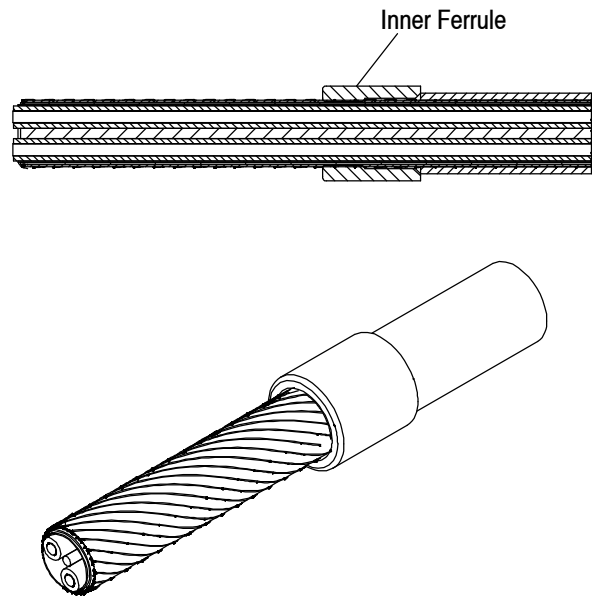

Figure 2 (cont'd)

2B



2C



2D

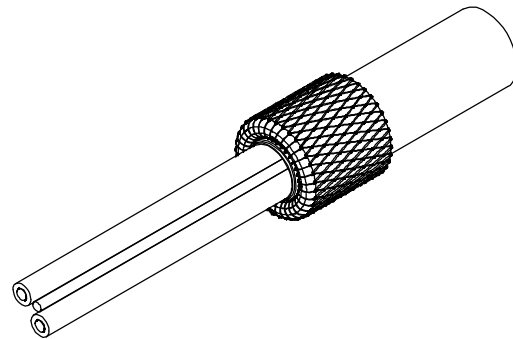
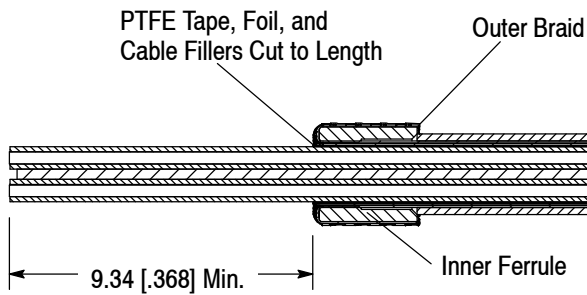

Figure 2 (end)

3.5. Discrete Wire Preparation

1. Fan out the two discrete wire conductors and strip away the insulation to the dimension as shown in Figure 3A.
2. Trim the inner core to the dimension as shown in Figure 3B.
3. Slide the pin or socket contact onto the wire as shown in Figure 3C.

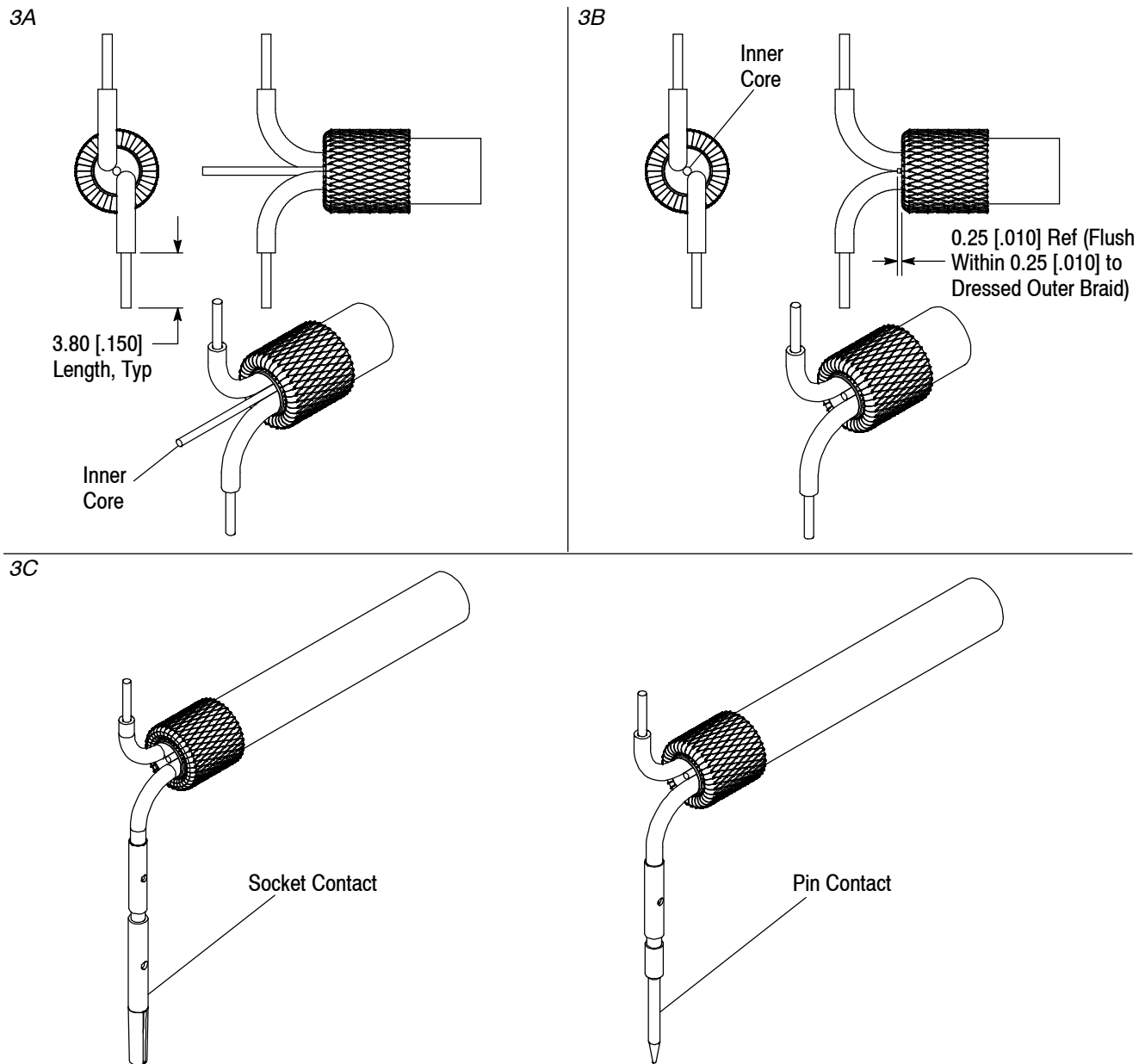

Figure 3

3.6. Crimped Contact Requirements

Crimp the pin or socket contacts, (two required), onto the stripped wires using crimping tool M22520/2-01 with die or positioner K709. Refer to Section 5, TOOLING and Instruction Sheet 408-7516. Refer to instructions packaged with crimp tooling for appropriate procedures.

A. Conductor Barrel Crimp

The crimp applied to the conductor barrel is the most compressed area and is most critical in ensuring optimum electrical and mechanical performance of the crimped contact. The conductor barrel crimp height must be within the dimension provided in Figure 4.

B. Effective Crimp Length

For optimum crimp effectiveness, the crimp must be within the area shown in Figure 4. Effective crimp length shall be defined as that portion of the conductor barrel, fully formed by the crimping tool. Instructions for adjusting, repairing, and inspecting tools are packaged with the tools. See Section 5, TOOLING.

NOTE: Pin contact shown, but requirements apply equally to the socket contact.

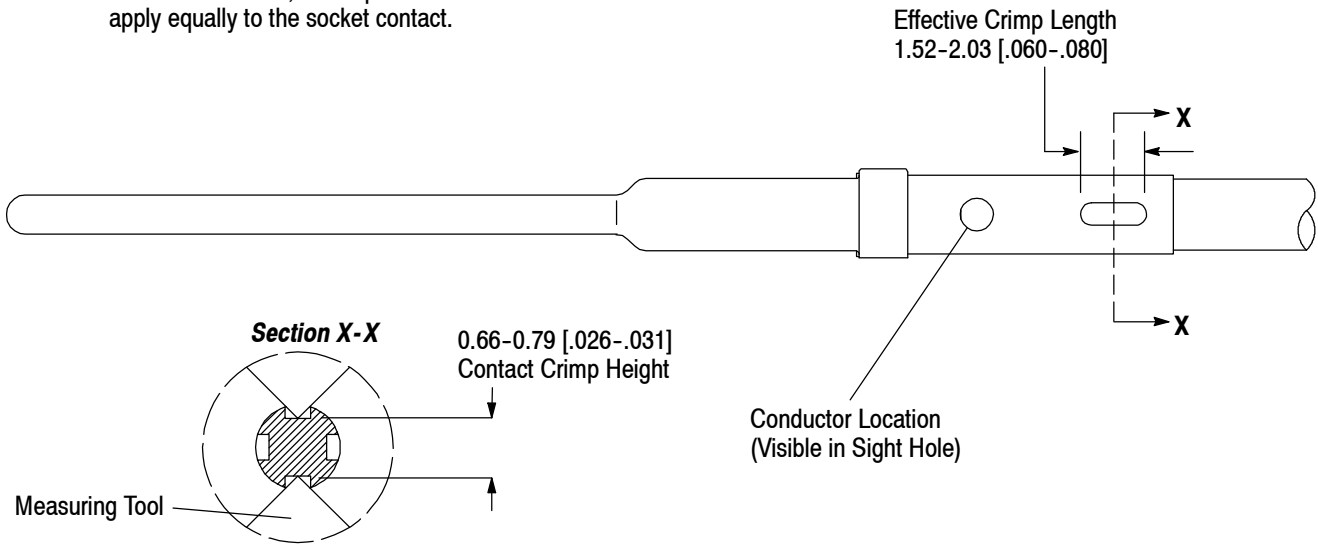

Figure 4

C. Twist and Roll

There shall be no twist, roll, deformation or other damage to the mating portion of the crimped contact that will prevent proper mating.

D. Straightness

The force applied during crimping may cause some bending between the crimped conductor barrel and the mating portion of the contact. Such deformation is acceptable within the limits shown in Figure 5.

1. Up and Down

The crimped contact shall not be bent above or below the datum line more than the amount shown in Figure 5.

2. Side to Side

The side-to-side bending of the contact may not exceed the limits provided in Figure 5.

NOTE

Periodic inspections must be made to ensure crimped contact formation is consistent as shown.



NOTE: Angles are drawn for clarification only and are not to scale.
Pin contact shown, but requirements apply equally to the socket contact.

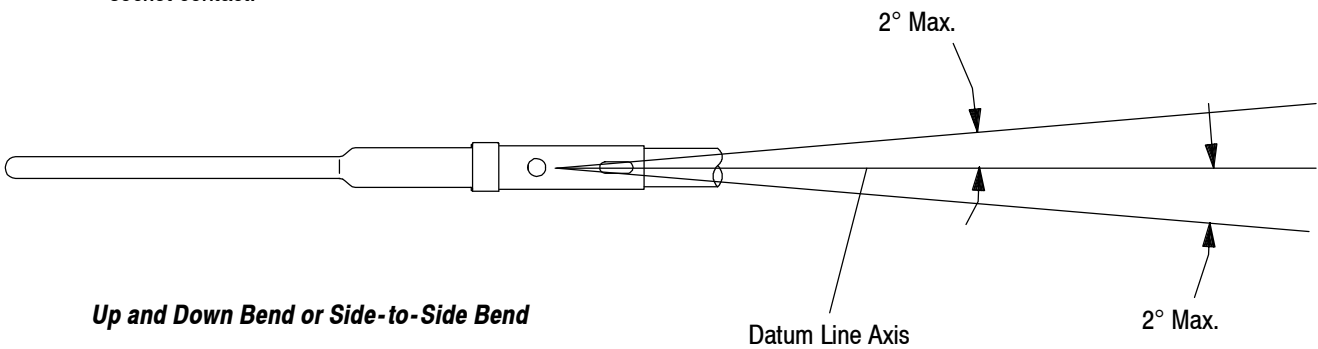

Figure 5

3.7. Pin Contact Assembly (Figure 6)

1. Insert pin contacts into the rear pin dielectric. The contact retention shoulder should extend through the dielectric.
2. Insert pin contacts into the front pin dielectric so that the keying slots on both dielectrics are aligned.
3. The back end of the dielectric should butt up against the inner ferrule/outer braid.
4. Insert and push the dielectric sub-assembly into the shell while keeping the slot on the dielectrics aligned with the wiring key on the outside of the shell.
5. Continue pushing until the dielectric sub-assembly visually bottoms.
6. Crimp the pin shell by placing the crimp portion of the contact into the crimp tooling as provided in Section 5, TOOLING. The hex crimp should measure 5.54 mm [.218 in.] nominal across the flats.
7. After crimping, slide the sealing boot (if used), over the crimp area until the seal bottoms on the contact.

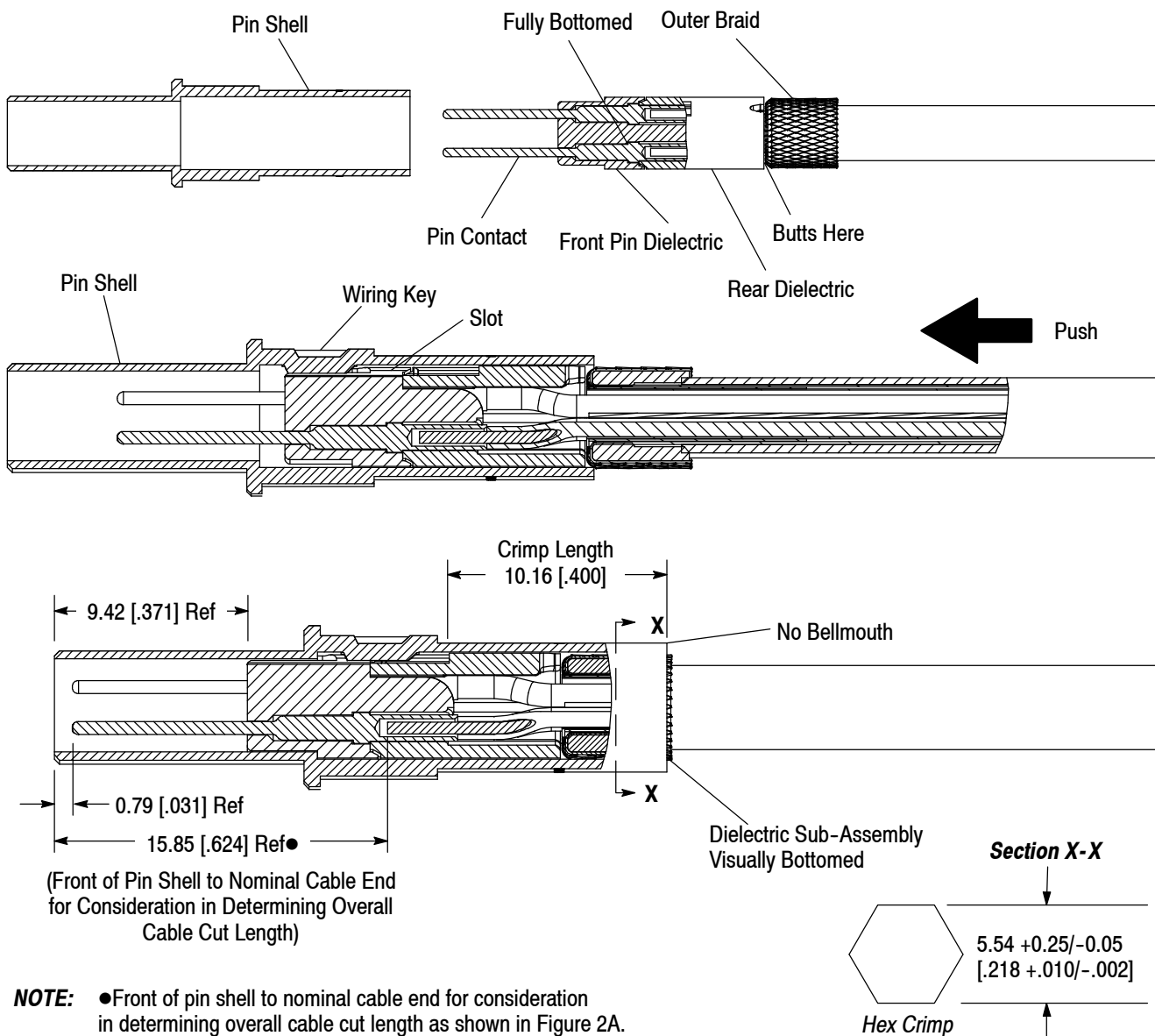
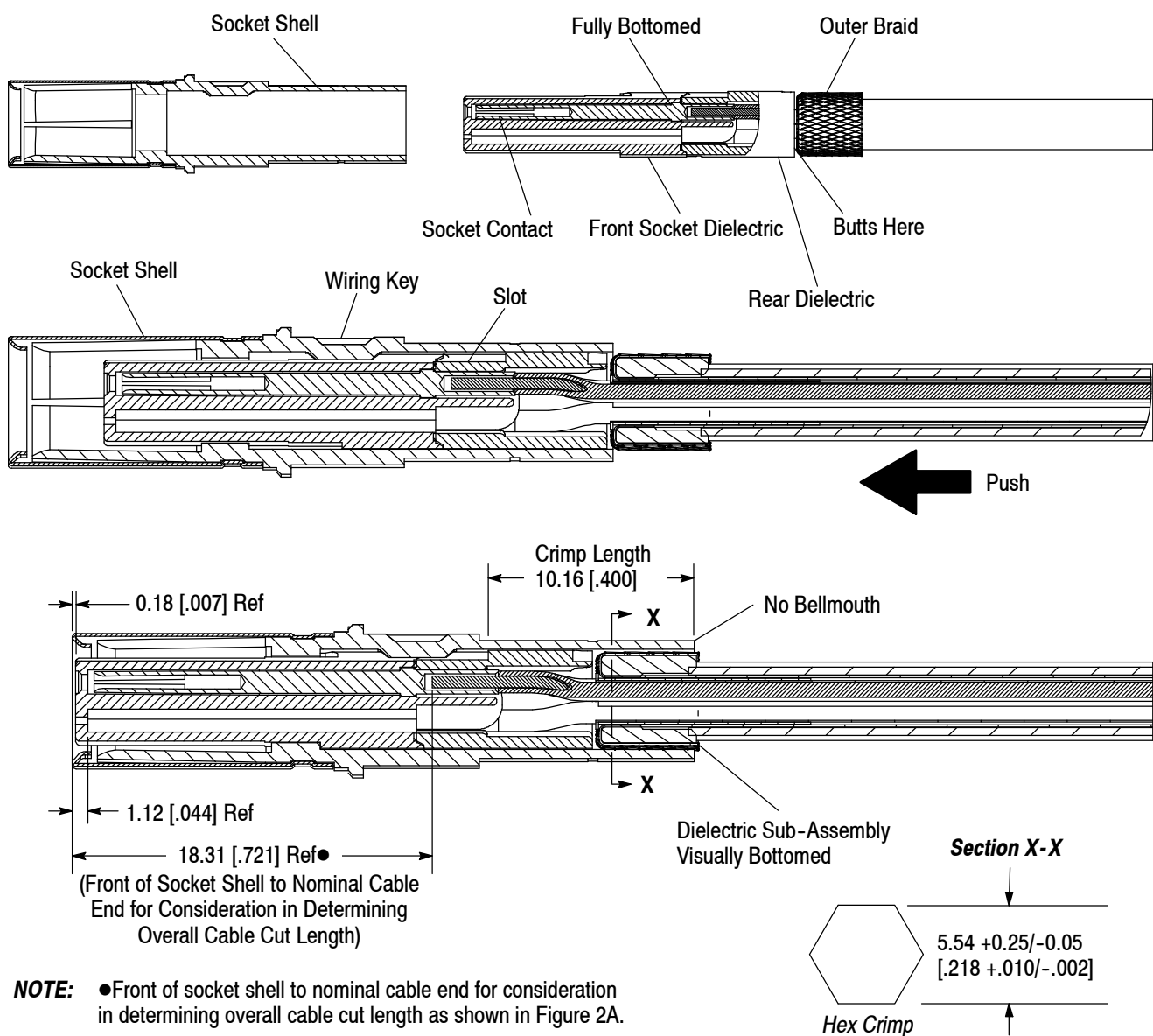

Figure 6

3.8. Socket Contact Assembly (Figure 7)

1. Insert socket contacts into socket dielectric. The contact retention shoulder should extend through the dielectric.
2. Insert pin contacts into the front pin dielectric so that the keying slots on both dielectrics are aligned.
3. The back end of the dielectric should butt up against the inner ferrule/outer braid.
4. Insert and push the dielectric sub-assembly into the shell while keeping the slot on the dielectrics aligned with the wiring key on the outside of the shell.
5. Continue pushing until the dielectric sub-assembly visually bottoms.
6. Crimp the socket shell by placing the crimp portion of the contact into the crimp tooling as provided in Section 5, TOOLING. This hex crimp should measure 5.54 mm [.218 in.] nominal across the flats.
7. After crimping, slide the sealing boot (if used), over the crimp area until the seal bottoms on the contact. Visually orient the sealing boot key with the contact positioning key.



NOTE: ●Front of socket shell to nominal cable end for consideration in determining overall cable cut length as shown in Figure 2A.

Figure 7

3.9. Repair/Replacement



Damaged components must not be used. If a damaged component is evident, it must be removed and replaced with a new one. Terminated contacts and ferrules must not be re-terminated.

4. QUALIFICATIONS

Non-Concentric Twinax Pin and Socket Assemblies have not been sent for agency evaluation and testing.

5. TOOLING

Non-Concentric Twinax Pin and Socket Assemblies and ferrules can be terminated using hand crimping tools that accommodate the wire size specified. Military (DANIELS) tool, positioner, and die sets are available to crimp the screw-machine pin or socket contact, and ferrule. See Figure 8 for recommended tooling.

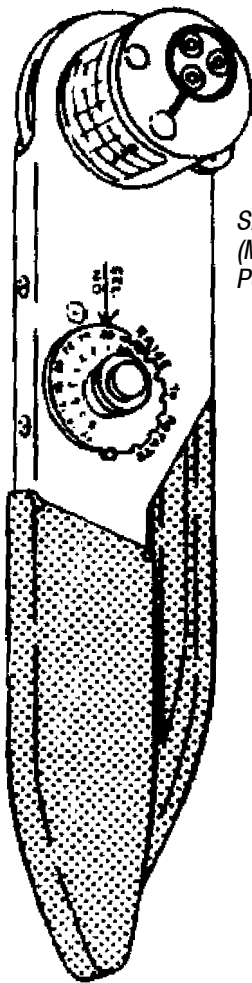

Signal Contact Termination
(Military) DANIELS Tool and Positioner

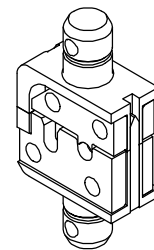
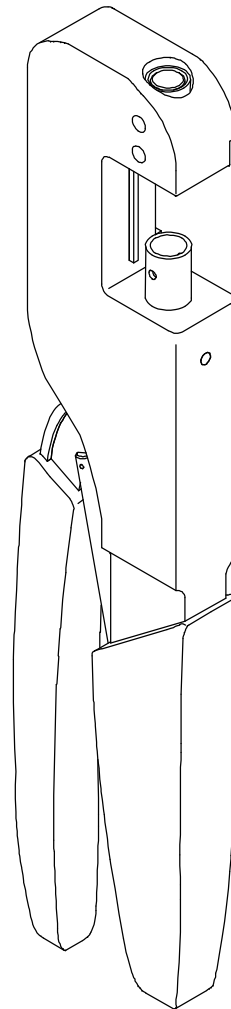

Ferrule Termination
(Military) DANIELS Tool and Die Set

WIRE SIZE (AWG)	CONTACT TYPE	CONTACT TERMINATION TOOLING			FERRULE TERMINATION TOOLING		RECOMMENDED EXTRACTION TOOL	RETENTION NUT TORQUE WRENCH
		HAND TOOL	POSITIONER OR DIE SET	SELECTOR SETTING	HAND TOOL	DIE SET		
24	Pin or Socket	M22520/2-01	K709	5	M22520/5-01 or 608650-1	M22520/5-45	1738894-1	1604972-1
26				4				

Figure 8

6. VISUAL AID

Figure 9 shows a typical application of a Non-Concentric Twinax Pin Assembly. These illustrations should be used by production personnel to ensure a correctly applied product. Applications which DO NOT appear correct should be inspected using the information in the preceding pages of this specification and in the instructional material shipped with the product or tooling.

NOTE: PIN CONTACT SHOWN, SOCKET CONTACT REQUIREMENTS ARE THE SAME.

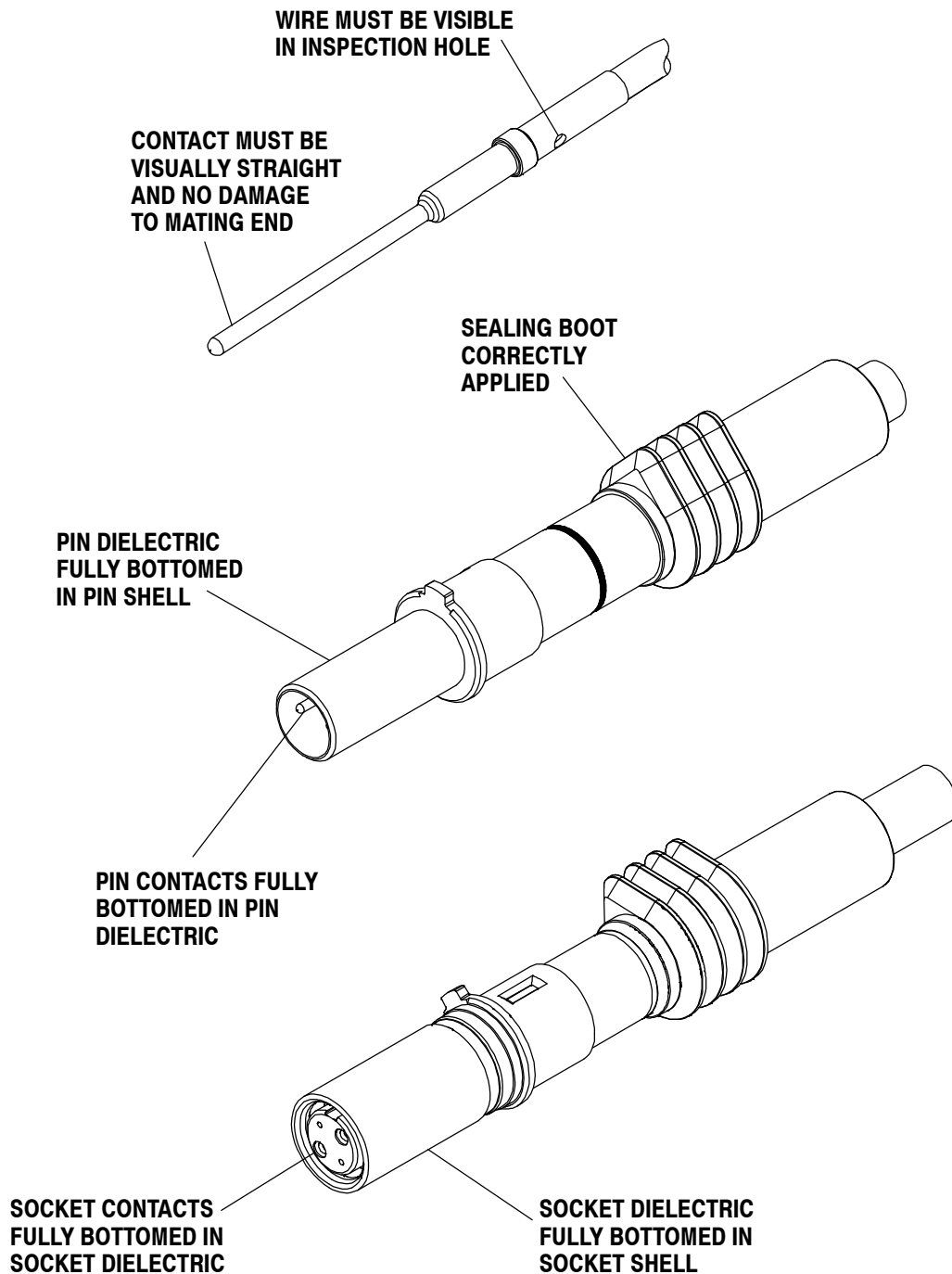

FIGURE 9. VISUAL AID