



**NOTE**

All numerical values are in metric units [with U.S. customary units in brackets]. Dimensions are in millimeters. Unless otherwise specified, dimensions have a tolerance of  $\pm 0.10$  mm and angles have a tolerance of  $\pm 2^\circ$ . Figures and illustrations are for identification only and are not drawn to scale.

**1. INTRODUCTION**

This application guideline covers the requirements for application of the LUMAWISE Drive LED Holder Type Z50: DALI-2 Series (hereafter referred to as LUMAWISE Drive: DALI-2 Series). The LUMAWISE Drive: DALI-2 Series allows direct attachment of the LED to a cooling device using two customer-supplied M3 or No. 4-40 with minimum length of 12mm mounting screws and has a 4 position CT connector (292228-4) to power and regulate the onboard driver. The LUMAWISE Drive: DALI-2 Series can be used in combination with a DALI-2 lighting system.

The LUMAWISE Drive: DALI-2 Series features a COB opening, 292228-4 Mini CT Connector and two screw holes that each accept a screw for mounting. The COB opening accepts the COB, and a visible LED minus (-) & plus (+) polarity indicator on the bottom of the LUMAWISE Drive: DALI-2 Series indicates orientation of the COB, the Light Emitting Surface is visible through the LES opening.

When corresponding with personnel, use the terminology provided in this specification to facilitate inquiries for information. Basic terms and features of this product are provided in Figure 1.

**Example of the LUMAWISE Drive Type Z50 DALI-2 Series**

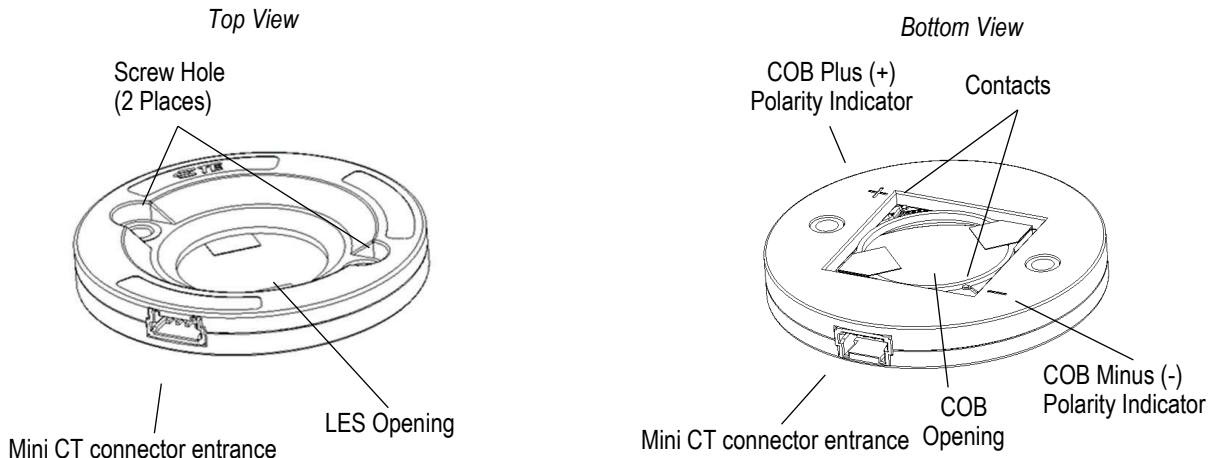

Figure 1

**2. REFERENCE MATERIAL**

**2.1. Customer Assistance**

Reference Product Base Part Number x-231651 1-y is representative of the LUMAWISE Drive LED Holder Type Z50: DALI-2 series. Use of these numbers will identify the product line and help you to obtain product and tooling information. Such information can be obtained through a local Representative, by visiting our website at [www.te.com](http://www.te.com), or by calling PRODUCT INFORMATION or the TOOLING ASSISTANCE CENTER at the numbers at the bottom of this page.

## 2.2. Specifications

Product Specification 108-133109 provides product performance and test information.

## 2.3. Instructional Material

Instruction Sheets (408-series) provide product assembly instructions.

## 2.4. Datasheet

Datasheet 1-1773948-6-LUMAWISE-Drive-LED-Holder-Ty provides general information about the product.

## 3. REQUIREMENTS

### 3.1. Safety

Do not stack product shipping containers so high that the containers buckle or deform.

It is recommended using the LUMAWISE Drive: DALI-2 Series (in combination with the COB) with low-voltage low energy circuits supplied from a class 2 or low-voltage limited energy (LVLE) power source, for EU Class I or II. Input and output of the power supply should be isolated from each other.

### 3.2. Storage

The LUMAWISE Drive: DALI-2 Series should remain in the shipping containers until ready for use to prevent deformation to the contacts. The LED holders must be stored in a temperature range of -20 to 60°C [-4 to 140°F] and used within 1 year from the date code located on the bottom of the holder. The LUMAWISE Drive: DALI-2 Series should be used on a first in, first out basis to avoid storage contamination that could adversely affect performance.

### 3.3. Functional overview

Figure 2 show an overview of the functional blocks of the LUMAWISE Drive: DALI-2 Series.

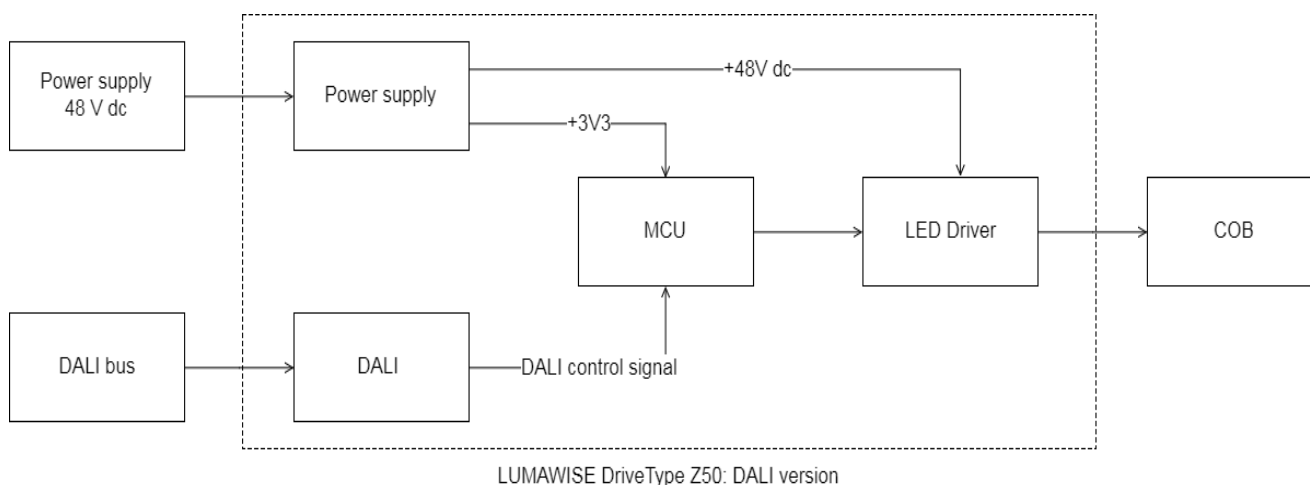

Figure 2

### 3.4. Signal information

Table 1 provide the pin numbers with signal names and description of the Mini CT Connector.

Pin	Signal	Description
1	DA	DALI signal (polarity insensitive)
2	DA	DALI signal (polarity insensitive)
3	U+	+48 V dc from power supply
4	U-	Ground / Common from 48 V dc power supply

Table 1

### 3.5. Power supply

A European class I & II or US NEC class 2 constant voltage supply, with isolated output of 48 V dc  $\pm$  10 % must be used to power the LUMAWISE Drive: DALI-2 Series. Maximum voltage output should not exceed 60 V dc. Input signal needs to be applied to line P3 (U+) and P4 (U-) of the connector. By removing/adding power to the system, the LUMAWISE Drive: DALI-2 Series turns off/on.

### 3.6. Dimming performance

To regulate the LED light intensity, a DALI signal needs to be applied to line P1 (DA) and line P2 (DA). If no signal is applied to P1 and P2, the output current is at maximum level. The actual dimming curve as per DALI standard, EN 62386-102, is shown in Figure 3.

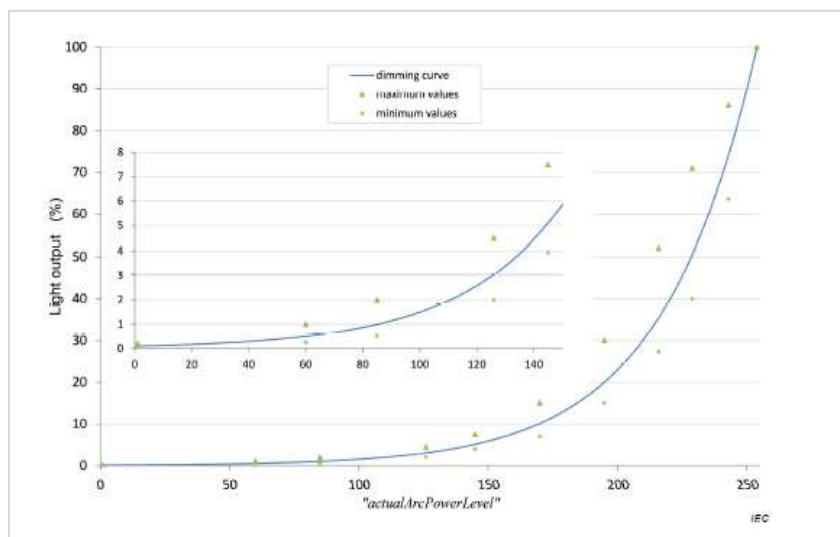

Figure 3

Product is compatible with all DALI controllers which are DALI-2 compliant, no class restrictions. If no control device is connected, output current is at maximum level.

### 3.7. COB

A COB of the following dimensions, 16x19 mm, 19x19 mm, 20x24 mm, 24x24 mm, can be used in combination with the LUMAWISE Drive: DALI-2 Series. The forward voltage range needs to comply with the typical forward voltage of 36 V dc of the LUMAWISE Drive: DALI-2 Series to achieve the efficiency of 92 %. If the forward voltage of the COB does not comply with the typical forward voltage of 36 V dc but is within the output range of 25 - 41 V dc, the LUMAWISE Drive: DALI-2 Series operates with a lower efficiency.

Check if the position of the contact pads corresponds with the position of the contacts of the LUMAWISE Drive: DALI-2 Series as shown in Figure 4. The contact points correspond with the Zhaga Book 12 COB dimensions. The Customer Drawing (C-2316511) includes a list with compatible COBs, for other COB types, please contact TE Connectivity.

**COB contact pads**

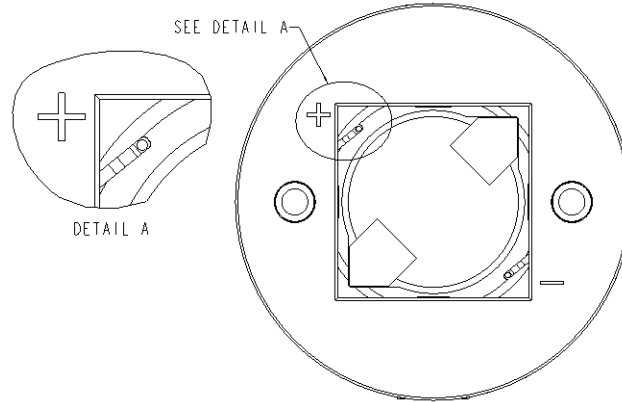

Note: Not to scale

Figure 4

### 3.8. Thermal management

The LUMAWISE Drive: DALI-2 Series is rated for 125 °C maximum operating temperature, measured at the driver chip. A Thermal Interface Material (TIM) is needed in between the cooling device (heatsink) and LUMAWISE Drive: DALI-2 Series with COB. An appropriate cooling device must be used to ensure chip rated temperature of maximum 125 °C is observed. Suggested TIM material is from Laird Technologies PN: AS00444-25 and is available to purchase through distributors.

A development kit is available for customers to perform initial tests and investigations. TE offers several variants of LUMAWISE Drive: DALI-2 Series as development kits. The kit includes, a LUMAWISE Drive: DALI-2 Series, a Mini CT connector cable assembly and a TIM sheet. These kits are available to purchase through various distributors. The available part numbers are listed in Table 2.

A temperature test point (Tc) is provided on the PCBA close to the driver chip (shown in Step 3) for tracking chip temperature. The temperature difference between the driver chip and the Tc is 15 °C. Tc temperature should not exceed 110 °C. Below instruction on how to measure the Tc temperature.

If the Tc point exceed the maximum temperature, the product goes in over-temperature protection mode. The output level will be reduced to 20 % of the maximum output level. The DALI-2 version needs to be switched off and on to exit this state.

The DALI-2 version collects data of every over-temperature event which did take place and this data is only accessible for TE Connectivity.

---

#### Step 1: Removing Top Cover

Push the cover wall inwards with fingers to disengage snaps. Disengage as per below shown order only.

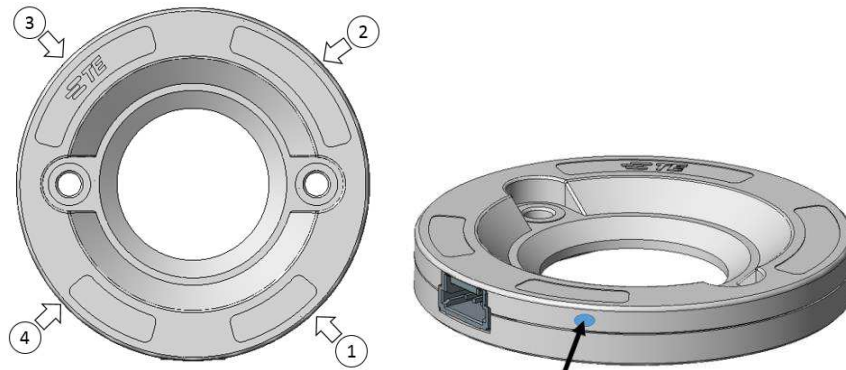

---

#### Step 2: Making hole in Top cover for Thermocouple wire

Drill a hole of approximately 1.2 time the size of the thermocouple wire at the marked location and pass the Thermocouple wire through the hole.

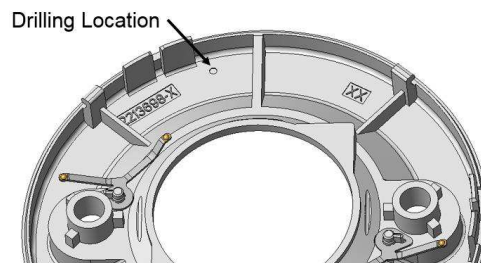



---

#### Step 3: Soldering Thermocouple to Tc point

Solder thermocouple to the Tc point pad on PCBA. Ensure adequate heat is applied for soldering.

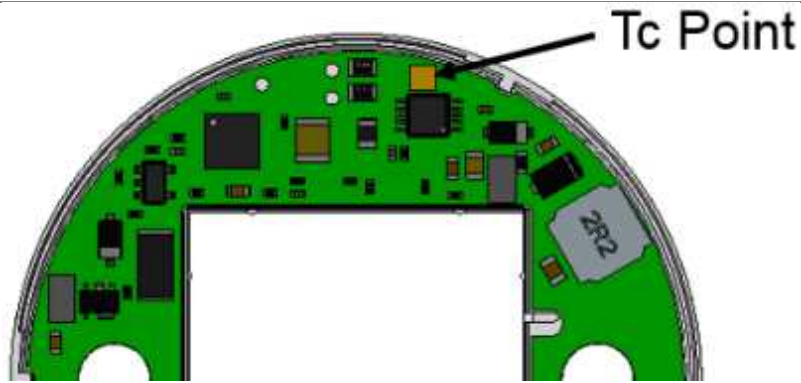
*Recommended thermocouple: Type K welded tip, Tip diameter 0.6 mm*



Re-assemble the Cover and ready for the test.

Kit Part Number	LED size	Output Current
2327915-1	19x19	350
2327915-2	16x19	350
1-2327915-1	20x24	500
1-2327915-2	19x19	500
1-2327915-3	16x19	500
2-2327915-1	24x24	700
2-2327915-2	20x24	700
2-2327915-3	19x19	700
2-2327915-4	16x19	700
3-2327915-1	24x24	1050
3-2327915-2	20x24	1050
3-2327915-3	19x19	1050

Table 2 Kit Part Numbers

<b>Product Part Number</b>	<b>LED size</b>	<b>Output Current</b>	<b>GTIN</b>
0-2316511-1	24x24	350	9421027422100
0-2316511-2	20x24	350	9421027422117
0-2316511-3	19x19	350	9421027422124
0-2316511-4	16x19	350	9421027422131
1-2316511-1	24x24	500	9421027422148
1-2316511-2	20x24	500	9421027422155
1-2316511-3	19x19	500	9421027422162
1-2316511-4	16x19	500	9421027422179
2-2316511-1	24x24	700	9421027422186
2-2316511-2	20x24	700	9421027422193
2-2316511-3	19x19	700	9421027422209
2-2316511-4	16x19	700	9421027422216
3-2316511-1	24x24	1050	9421027422223
3-2316511-2	20x24	1050	9421027422230
3-2316511-3	19x19	1050	9421027422247
3-2316511-4	16x19	1050	9421027422254

*Table 3 Product Part Numbers & GTIN Numbers*

### 3.9. Connecting the LUMAWISE Drive: DALI-2 Series

Connecting the LUMAWISE Drive: DALI-2 Series is done with the below showed cable assembly. The Mini CT mating connector has part number 353908-4.

*Connector overview and connection scheme*

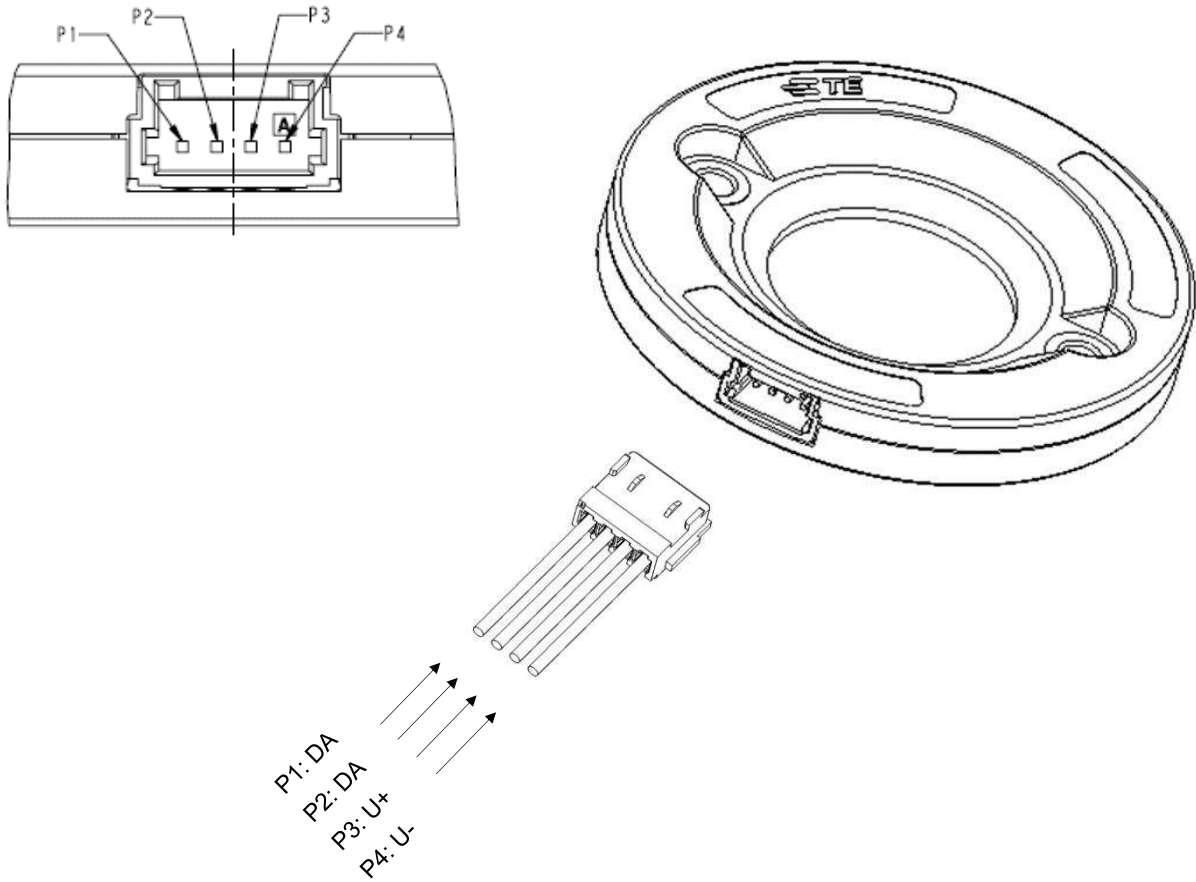

Note: Not to scale

Figure 5



### 3.10. Mounting Hole Pattern

The cooling device must be clean and flat with no crowns or peaks in the mounting area. The recommended mounting hole pattern (not to scale) is provided on the customer drawing for the LUMAWISE Drive: DALI-2 Series and is shown in Figure 6, Mounting Hole Pattern.

After the holes are drilled and tapped, the surface must be cleaned with isopropyl alcohol. It is recommended to install a paste or phase-change type thermal interface material (TIM) onto the COB area of the cooling device.

Please note the holder is designed for flathead screws only.

#### Mounting hole pattern

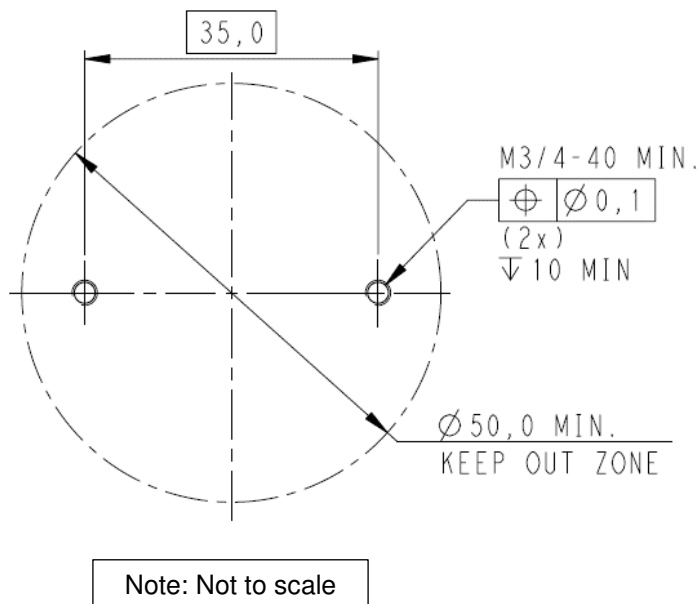

Figure 6

### 3.11. Reflector and optic clip

The LUMAWISE Drive: DALI-2 Series is compatible with the Z50 optic clip type 1 and type 2 (part numbers: 2213194 and 2213349) to attach a reflector to the LUMAWISE Drive: DALI-2 Series in order to create a directional beam of light. For assembly instructions, please refer to the application sheet of the optic clip.

### 3.12. Assembly



#### CAUTION

The LUMAWISE Drive: DALI-2 Series is designed for use in a ventilated environment that allows volatile organic compound (VOC) escaping. To avoid damage to the LED, reflection of LED light from a diffuser directly onto the surface of the LUMAWISE Drive: DALI-2 Series must be prevented as much as possible.

1. The LUMAWISE Drive: DALI-2 Series is suitable for the following COB sizes: 16x19 mm, 19x19 mm, 20x24 mm, 24x24 mm. All with a nominal thickness of 1 mm.
2. Remove release liner of adhesive tape, insert the COB and ensure you do not press the light emitting (yellow part) part of the COB. The LED polarity indicator must be observed when orienting the COB into the COB opening. Light pressure needs to be applied to the bottom of the COB to overcome the resistance of the crush ribs, which ensures centralization of the COB in the LUMAWISE Drive: DALI-2 Series. The COB will stay in place thanks to the adhesive tape. See Figure 7, details A.



#### CAUTION

To avoid damage to the LED, the COB must be properly positioned and seated in the LUMAWISE Drive: DALI-2 Series. If not, the COB could crack when mounting the LUMAWISE Drive: DALI-2 Series to the cooling device.

3. The LUMAWISE Drive: DALI-2 Series (bottom side) must be placed on the cooling device with TIM material recommended phase change style or grease in between, so that the screws holes align over the holes in the cooling device. The LUMAWISE Drive: DALI-2 Series must be secured to the cooling device using two customer-supplied M3 or No. 4-40 with minimum length of 12 mm mounting screws. Each mounting screw should be tightened to a torque between 0.4 Nm and 0.6 Nm [3.45 and 5.31 in.-lb]. See Figure 7, detail B.

4. Insert the Mini CT connector into the socket before energizing, please ensure the keying is in the correct position. See Figure 7, detail C.

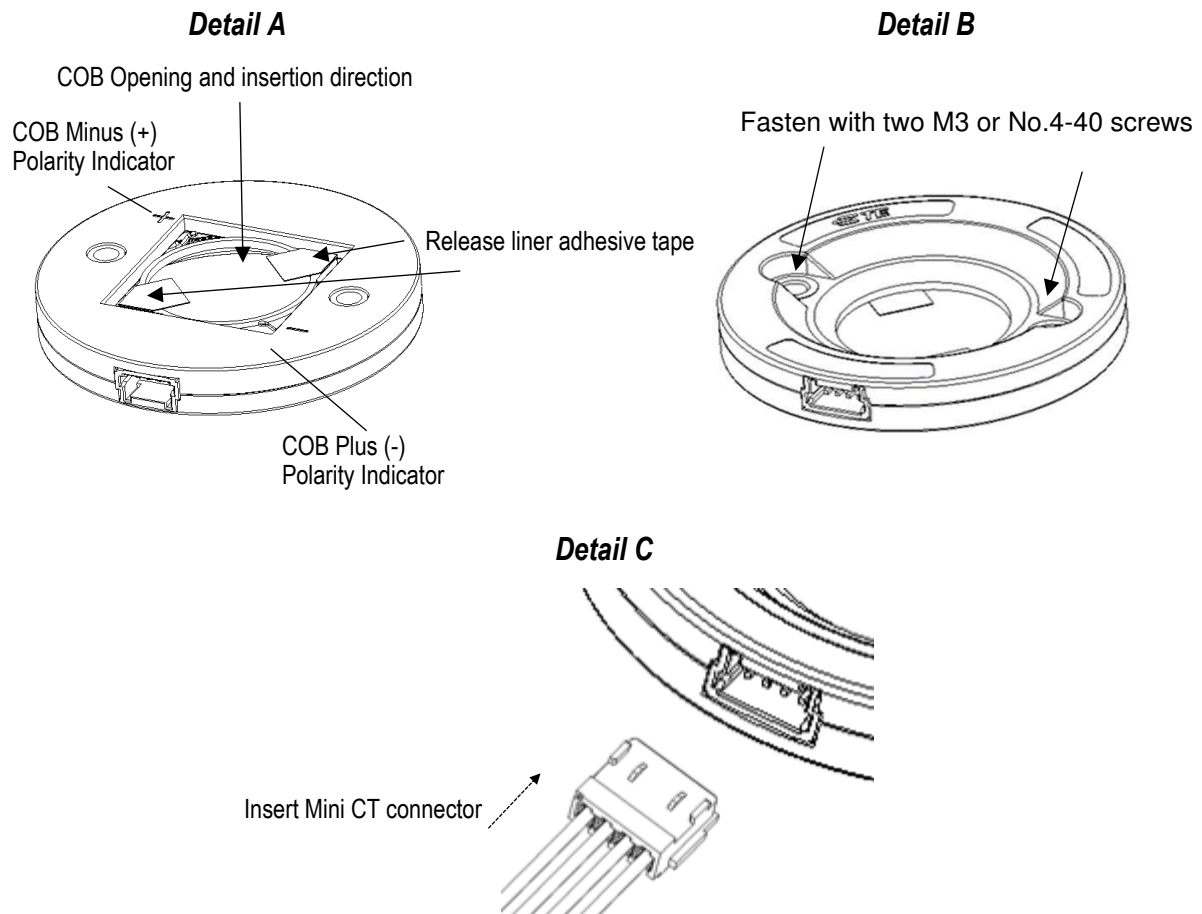

Figure 7

### 3.13. Removal

The LUMAWISE Drive: DALI-2 Series can be removed from the cooling device by removing the customer-supplied mounting screws. TIM material must be removed from heatsink and holder and new need to be applied.

### 3.14. Replacement and Repair

Defective or damaged LUMAWISE Drive: DALI-2 Series products must not be used.

### 3.15. Luminaire

Luminaire needs to be designed in such a way that no dust can accumulate on the holder or LED and humidity will remain within the set limits.

#### 4. QUALIFICATION

501- 19267	TE Connectivity product qualification report
IEC 61347-2-13	Dekra certificate number: 2224069.50
IEC 55015	Dekra certificate number: 2231611.01
IEC 61547	Dekra certificate number: 2231611.01
UL 8754	UL file number: E469276, Vol 1;2
UL 8750	UL file number: E469276, Vol 1;2
DALI-2	<a href="https://www.digitalilluminationinterface.org">https://www.digitalilluminationinterface.org</a>

#### 5. TOOLING

A suitable screwdriver with a torque limitation is required to tighten the customer-supplied mounting screws for mounting the LUMAWISE Drive: DALI-2 Series to the cooling device.

#### 6. COMMISSIONING

In accordance with the DALI standard, the LUMAWISE Drive can be individually configured and the parameters are held in the memory. The parameters that can be configured are:

- a. Light levels
- b. Fade time and rate
- c. Address (up to 64)
- d. Groups assigned to the ballast (up to 16)
- e. Light scene values assigned to the ballast (up to 16)

The two-way communication of the DALI bus enables the feedback on information such as:

- a. Luminaire state (on/off)
- b. Lamp energy level
- c. Lamp and ballast condition

The commissioning of the LUMAWISE Drive in a DALI system depends primarily on the control device used, so the respective manufacturer's instructions must be followed.

This section outlines the basic commissioning procedures as defined by the DALI standard:

- a. Assigning Addresses:

Identification of the of the LUMAWISE Drive is possible as soon as the control device and power supply have been connected. The search for DALI users can be done in two different ways:

- The control device registers all operating devices connected to the DALI system using its own basic ID stored by the manufacturer during production (address length is 24 bit). If two addresses are identical, a random function triggered by the control device can be performed within the ballast, creating a new address.
- The DALI user will be identified by disconnecting the lamp connection at the operating device. (The operating device must be connected to the power at this time.)

In each case, upon their identification, an individual and/or a group address will be assigned to each known DALI user according to the layout requirements.

Addresses can also be assigned prior to installation, allowing harmonization of all DALI operating devices

- b. Using Individual Addresses:

The assignment of an individual address will enable each operating device to be checked and/or error-detected.

- c. Using the Group Address:

Group addresses can be assigned to any combination of operating devices. This provides combined control of a group. Each ballast can belong to as many as 16 groups. Group addresses can be assigned by the user via control device during the identification phase. detailed in the preceding Section "Assigning Addresses".

Grouping can be easily changed later as occupancy or room usage changes.

- d. **Creating and Storing Lighting Scenes:**  
Once the individual operating device has been identified or groups have been assigned, lighting scenes can be created by setting the individual lighting levels for the individual devices or groups. The individual scenes are programmed via the controller and sent to the individual DALI operating devices (ballasts) where they are actually stored. A maximum of 16 scenes or light levels can be stored for each user. Scenes can be easily changed later as occupancy or room usage changes.
- e. **Commissioning after System Modification:**  
Whenever new devices are added, or existing devices replaced, the new users of the control device need to be identified according to the procedure detailed in Section “Assigning Addresses”. This can be done by changing all the addresses or just the selected addresses in accordance with the particular control system. Operating instructions for the control device should be followed.

For more information on DALI commissioning and control please be referred to following standards:

- [1] International Standard IEC 62386-101:2014 Digital addressable lighting interface Part 101: General requirements – System components
- [2] International Standard IEC 62386-102:2014 Digital addressable lighting interface Part 102: General requirements – Control gear.