H3A IP65 Hood and Housing series

Table of contents

1. INTRODUCTION	2
2. SUPPORTING DOCUMENTS	2
2.1. Customer drawings	2
2.2. Product specification	2
2.3. Standards	2
3. DESCRIPTION.....	3
3.1. Hood types	4
3.2. Housing types- Bulkhead mounted housing	4
3.3. Housing types– Surface mounted housing	5
3.4. Housing types– Cable-to-Cable Housing	5
4. REQUIREMENTS	6
4.1. Panel cut-out	6
4.2. Locking	6
4.3. Inserts assembly	7
5. ACCESSORIES	7
6. STORAGE.....	7

1. INTRODUCTION

This specification contains the regulations for assembly of various H3A Metal Hood and Housing. The following components are available in this system:
Hood and housing: H3A (metal hood & housing)

2. SUPPORTING DOCUMENTS

2.1. Customer drawings

Please refer to the relative customer drawing of H3A Metal Hood and Housing.

2.2. Product specification

The product specifications of the used articles are to be taken into account. The product specification describes the technical data as e.g. regulations, temperature range and degree of protection. For further reference refer Product spec. 108-137012.

2.3. Standards

- EN 61984: Connectors - Safety requirements and tests
- IEC 60664-1: Insulation coordination for equipment within low-voltage systems (Part 1)
- EN 60529: Degrees of Protection Provided by Enclosures (IP Code)
- EN 60068: Environmental testing

3. DESCRIPTION

This application specification describes Hood and Housing series.
The following picture in figure 1 shows a complete assembly H3A Hood and Housing with locking.

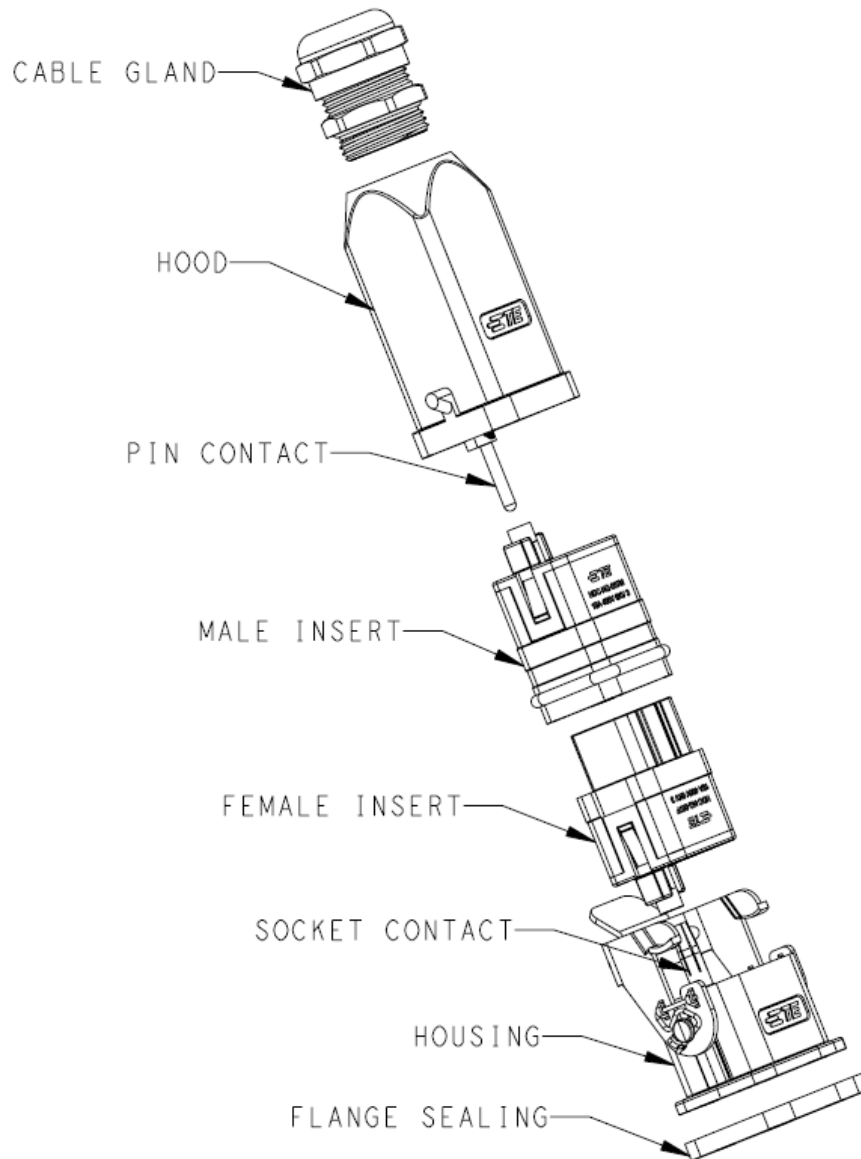
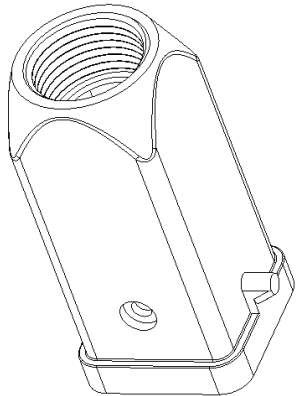

Figure: 1

The product consists of the following components (see Figure 1):

- Hood and Housing
- Male and female inserts
- Pin and socket contact
- Cable gland
- Flange seal

3.1. Hood types



H3A-MTG
Top entry
with 2 bolt

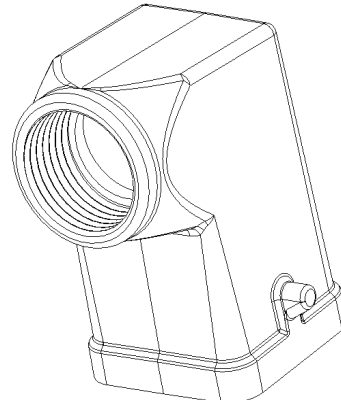

H3A-MTS
Side entry
with 2 bolt

3.2. Housing types- Bulkhead mounted housing

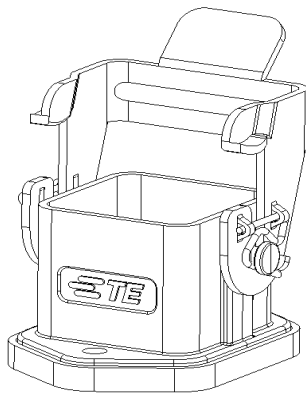

H3A-MAG
Bottom entry
with 1 level locking

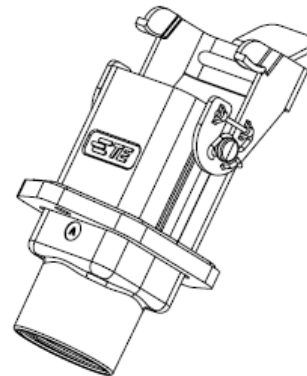

H3A-MAG-PG/M
Bottom entry with PG/M thread
with 1 level locking

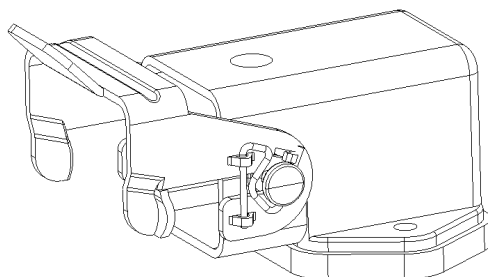

H3A-MAGS
Side entry
with 1 level locking

3.3. Housing types– Surface mounted housing

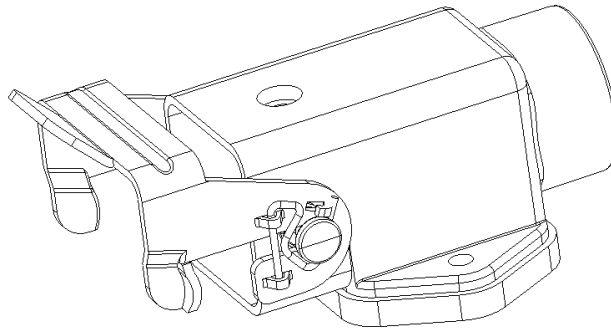

H3A-MAGSV
Side entry
with 1 level locking

3.4. Housing types– Cable-to-Cable Housing

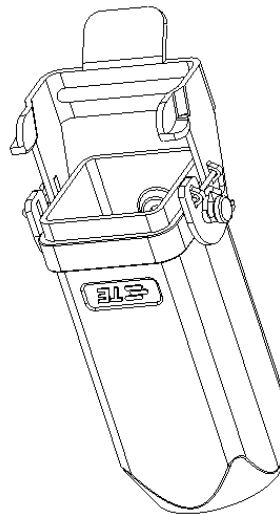

H3A-MTGVB
with 1 level locking

4. REQUIREMENTS

4.1. Panel cut-out

For information concerning the panel cut-out for the use of bulkhead mounted housing or surface mounted housings on panels please refer to the customer drawings. For example as shown in Figure 2 and related dimension refer to the customer drawings.

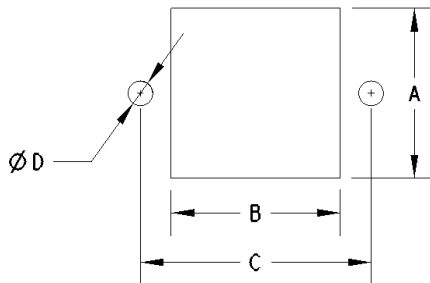

Figure 2

Note: Fixing screws for the assembly housings on panel are not part of the scope of delivery. It can be chosen suitable type according to size of hole on panel. Initial and test-torque values can be chosen from the following table:

M3	0.5 Nm
----	--------

4.2. Locking

A complete locking system with locking consists of the following components, as shown in Figure 3. The locking is used for the locking of the housing and hood. The locking is fixed on the housing and have to be pushed up to lock the hood.

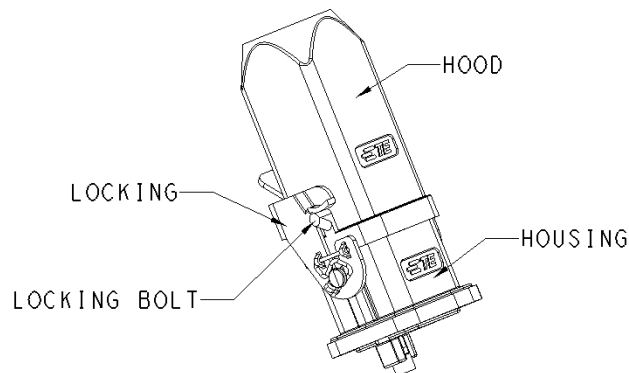

Figure: 3

4.3. Inserts assembly

The inserts are fixed into the hood/housing with M3 fixing screw and O-ring. And these M3 fixing screw and O-Ring are components on inserts. For example as shown in Figure 4.

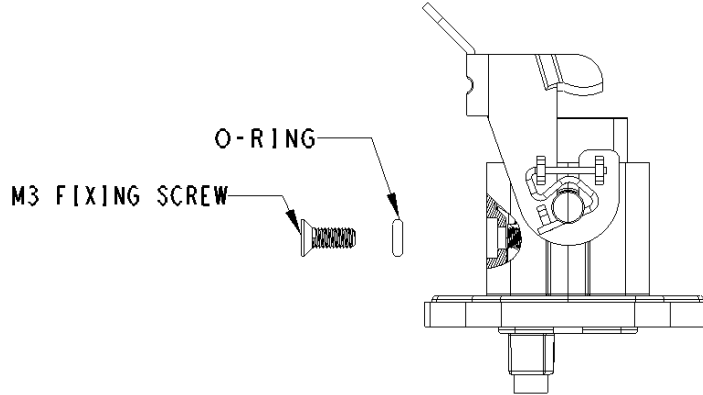

Figure: 4

Initial and test-torque values can be chosen from the following table:

M3	0.5 Nm
----	--------

5. ACCESSORIES

For the selection and specification of cable glands, please refer to our catalogue.

The possible arrangement of fitting depends on the hood selection. All hood versions have M-threads and PG-threads. For example, the hood and housing can be assembled with the adaptors and cable gland (plastic or metal). As shown in Figure 5.



Figure: 5

6. STORAGE

The connectors should be stored in the air ventilation, no corrosive gas, no rain and no snow in the warehouse. Relative humidity: less than 85% RH.