



All numerical values are in metric units [with U.S. customary units in brackets]. Dimensions are in millimeters. Figures and illustrations are for identification only and are not drawn to scale.

### 1. INTRODUCTION

This specification covers the requirements for application of the Industrial Din Rail Type Screw Clamp Terminal Block Connector Series in production and manufacturing environments. The connector series includes the products shown in table 1. All of the connectors in this product line are Din Rail Type Screw Clamp Terminal Block per UL1059 and IEC60947-7-1, IEC60947-7-2, IEC60947-7-3

When corresponding with TE Connectivity Personnel, use the terminology provided in this specification to facilitate your inquiries for information. Basic terms and features of this product are provided in Figure 1.

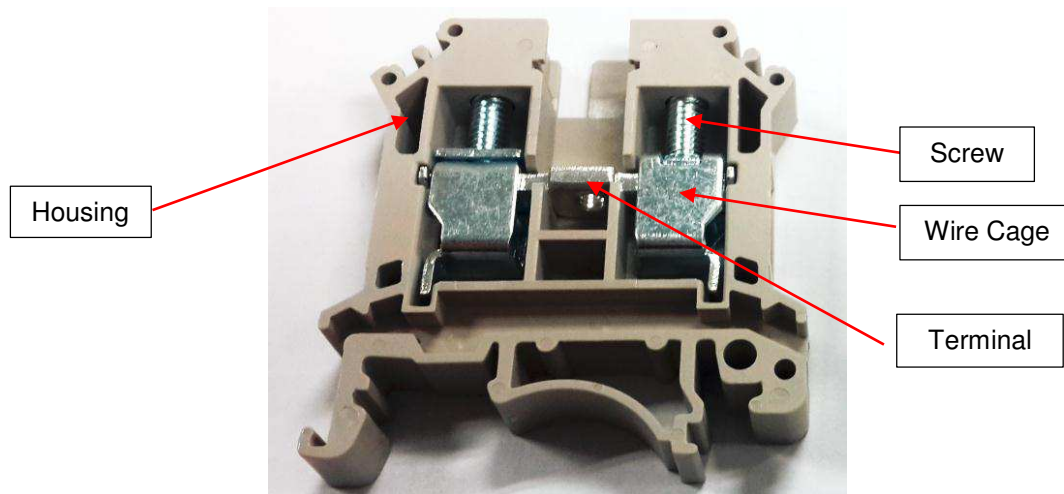

Figure 1.1

### 2. REFERENCE MATERIAL

#### 2.1 Revision Summary

Initial release of document

#### 2.2 Customer Assistance

Reference Product Base Part Numbers in TE's product C-drawing for every series. Use of these numbers will identify the product line and help you to obtain product and tooling information. Such information can be obtained through a local Representative, by visiting our website at [www.te.com](http://www.te.com), or by calling **PRODUCT INFORMATION** or the **TOOLING ASSISTANCE CENTER** at the numbers searched in the website.

#### 2.3 Drawings

Customer Drawings for specific products are available from the responsible Engineering Department via the service network. The information contained in the Customer Drawings takes priority if there is a conflict with this specification or with any other technical documentation supplied by TE.

#### 2.4 Specifications

Design Objective 108-137172, 108-137173 and 108-137182 provides expected test and performance requirements.

### 3. REQUIREMENTS

#### 3.1 Safety

Do not stack product shipping containers so high that the containers buckle or deform.

#### 3.2 Storage

##### A. Ultraviolet Light

Prolonged exposure to ultraviolet light may deteriorate the chemical composition used in the connector housings material.

##### B. Shelf Life

The connectors should remain in the shipping containers until ready for use to prevent deformation to those components. The components should be used on a first in, first out basis to avoid storage contamination that could adversely affect signal transmissions.

##### C. Chemical Exposure

Do not store connectors near any chemicals listed below as they may cause stress corrosion cracking in the contacts.

Alkalies/Ammonia Citrates/Phosphates Citrates/Sulfur Compounds  
Amines Carbonates Nitrites/Sulfur Nitrites/Tartrates

### 4. ASSEMBLY INSTRUCTION

Din rail spring type products and accessories should be assembled to rail when customer using them, below picture is the overview for the general assembly (see figure 2).

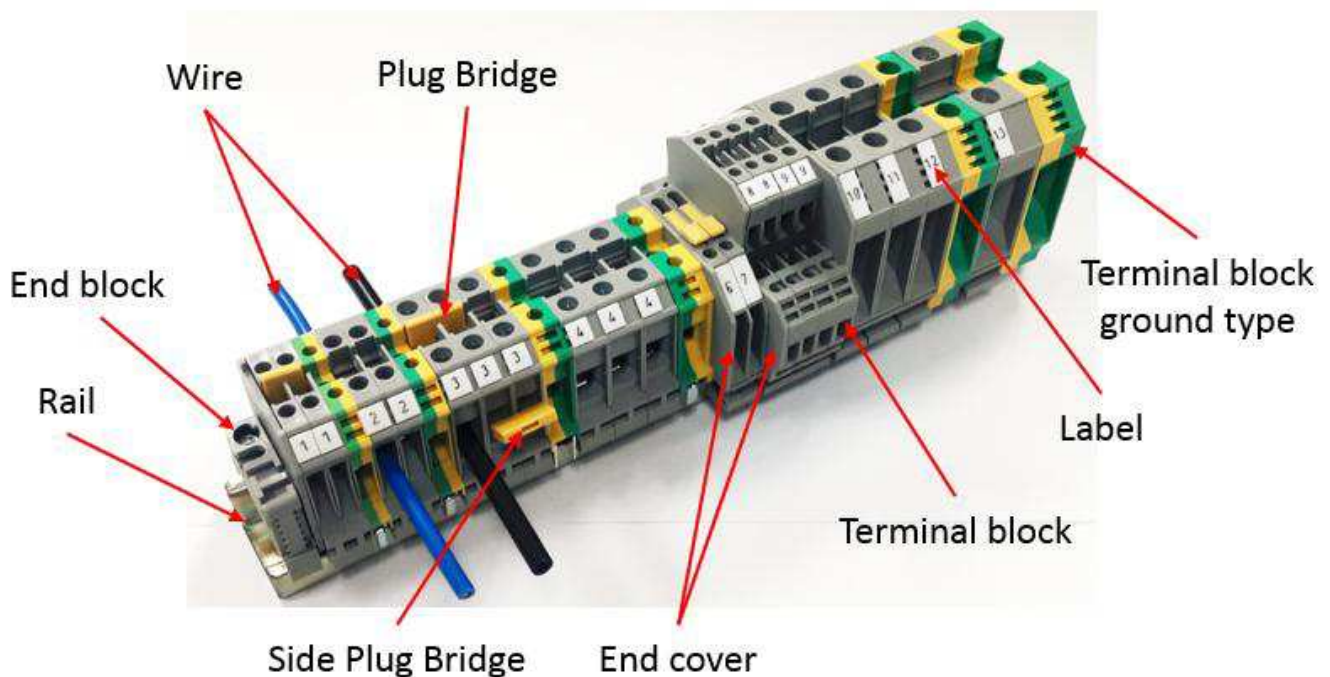

**Figure 2**

#### 4.1 Wire Field Assembly

**The recommended wires which are applicable for spring terminal block should be solid wire or 7 stranded wire.**

A. Wire stripped

Selecting the wire of suitable size recommended in product customer drawings or the remark on product for Preprocessing as figure 3. The wire must be stripped the plastic, the length of bare wire can follow table 1 or follow the customer drawings. The wire should have no sharp edges or corners that can damage conductor insulation with which it may come in contact.

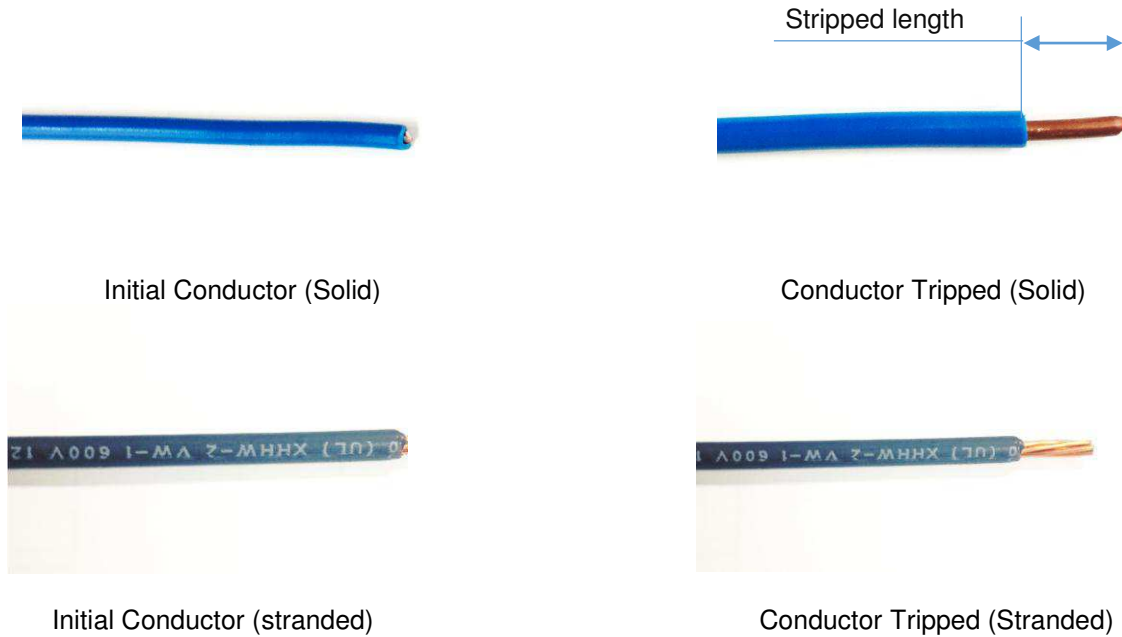

Figure 3 Wire stripped

Table 1 Wire stripped length

Conductor Section	TE Product Series	Stripped length of Wire
2.5mm <sup>2</sup>	DTC2.5, DTC2.5*	8-10mm
4mm <sup>2</sup>	DTC4, DTC4-G, DTC 4 DO, DTC 4 DOC	8-10mm
	DTC 4-PL, DTC 4-SW, DTC4-SSW, DTC 4-FU*	10-12mm
6mm <sup>2</sup>	DTC 6, DTC 6-G, DTC 6-EL	10-12mm
10mm <sup>2</sup>	DTC10, DTC10*	10-12mm
16mm <sup>2</sup>	DTC16	15-17mm
16mm <sup>2</sup>	DTC16-G	14-18mm
35mm <sup>2</sup>	DTC35	16-18mm
35mm <sup>2</sup>	DTC35*	14-18mm

B. Wire connection

The detail function of the holes see Figure 4, tools see figure 5.

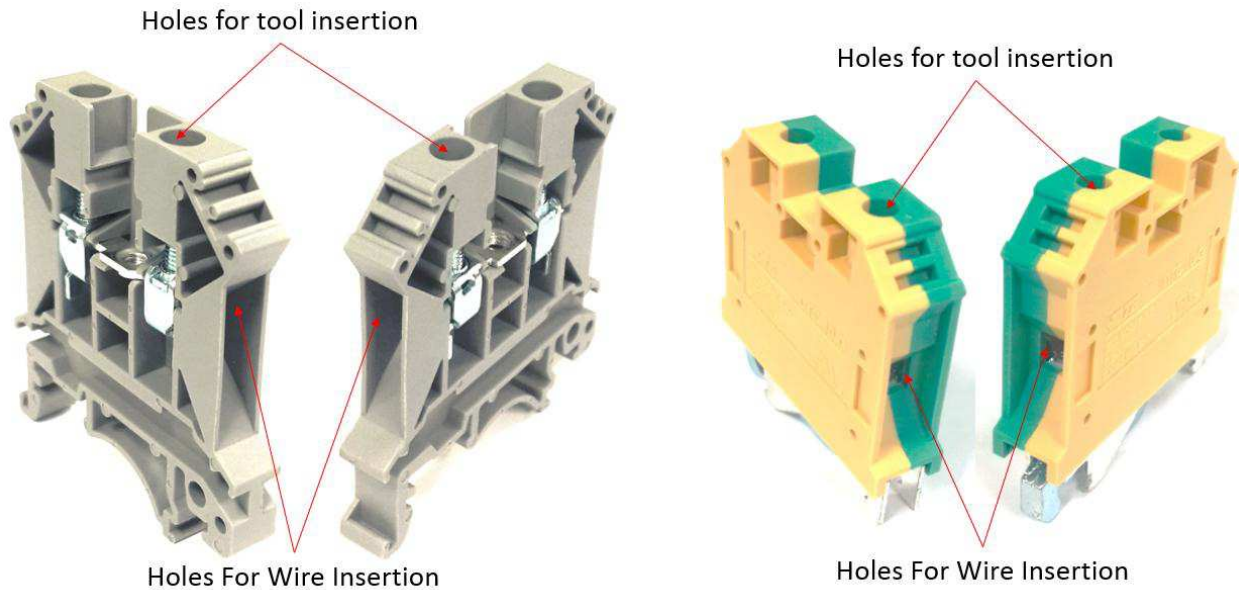

Figure 4



Figure 5 Tools

After finishing stripping the conductor, then insert the conductor into the hole of clamp using the tool, detail conductor connection process see below steps: (Figure 6):

- 1> Insert the wire into the right hole for wire insertion
- 2> Insert the tool to the hole of terminal block for tools insertion
- 3> Tightening the screw with the torque stated in customer drawings.
- 4> Pull out the tool from the hole of product



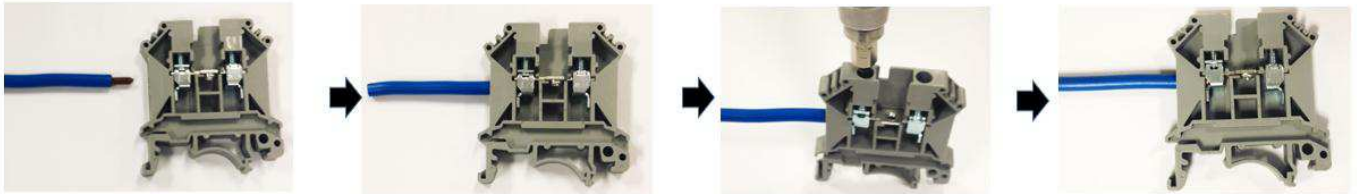

Figure 6 Wire connection

Follow the same steps, insert other conductors into the other holes of clamps (figure 7), then inspect the connection of conductor to ensure the wire is connected correctly.

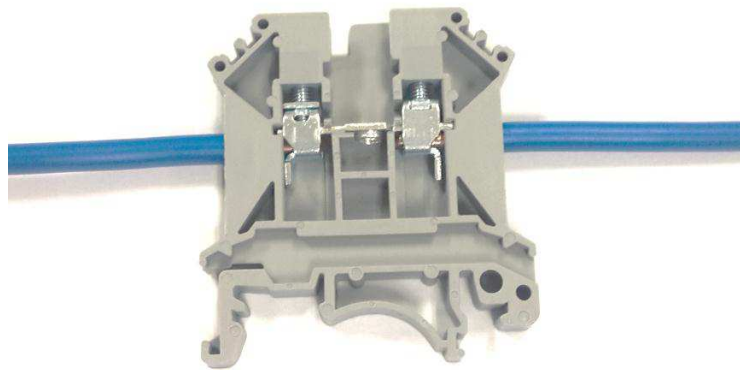

Figure 7

C. Wire removing

Using the suitable tool to removing the wire. Detail process should refer to below steps:

- 1>Insert the tool into the hole for tools insertion and loose the screw
- 2>Pull out the wire from the connection hole of product completely
- 3>Repeat the same action as 1> and 2> to remove the other wires

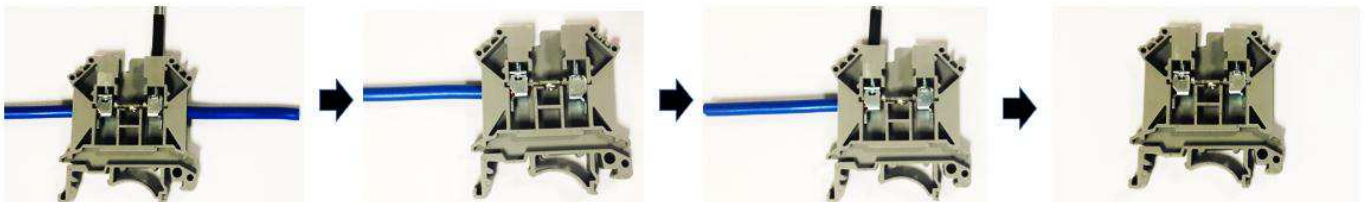

Figure 8 Wire removing

**4.2 Products fixing to Din rail and removing**

Products includes terminal block connectors and end block need to assembly to DIN rail.

The recommended mounting Din Rail should be TE product 2271573-1/2271573-2 or the rail meet IEC60715 standard.

A. Terminal block connector fixing to Din Rail.

For terminal block product, the fixing process of product to Din rail should follow below steps (figure 9.1& 9.3):

- 1> Inserting the rail edge into the right side of product latching space which has no elasticity;
- 2> Pressing the product to make the left latch which has elasticity lock the rail.

For Protective conductor terminal blocks, the fixing process of product to Din rail should follow below steps:

- 1>Inserting the rail edge into the right groove of product latching space as figure 9.2&9.4;
- 2>Tightening the screw with the torque stated in customer drawings.

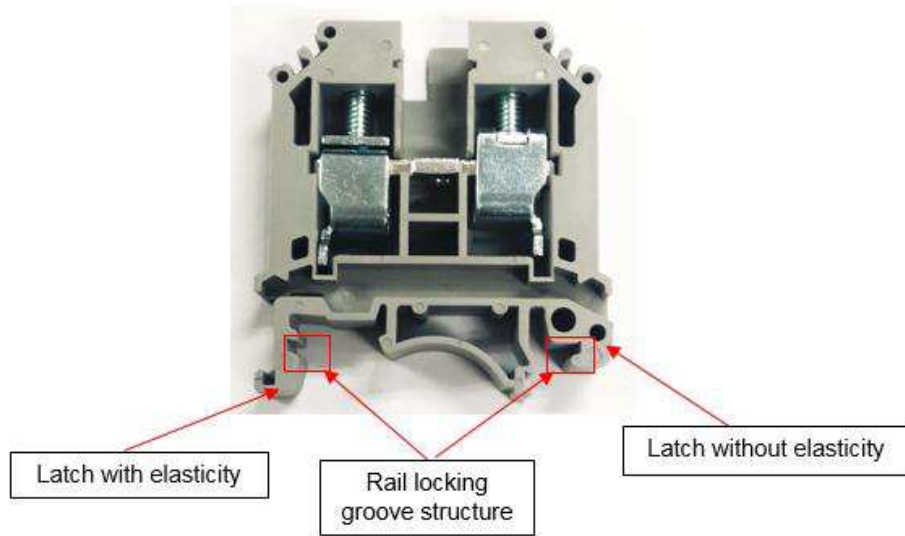

Figure 9.1 Terminal block without ground function

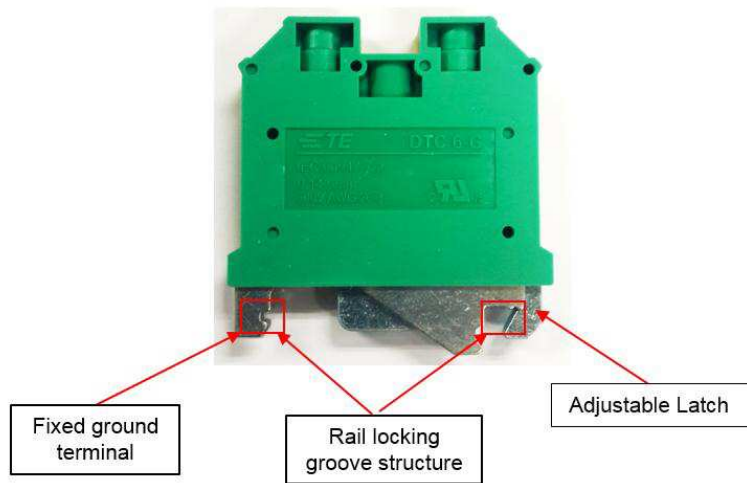

Figure 9.2 Protective Conductor Terminal block (With ground function)



Figure 9.3 Product (without ground function) fixing to Din Rail

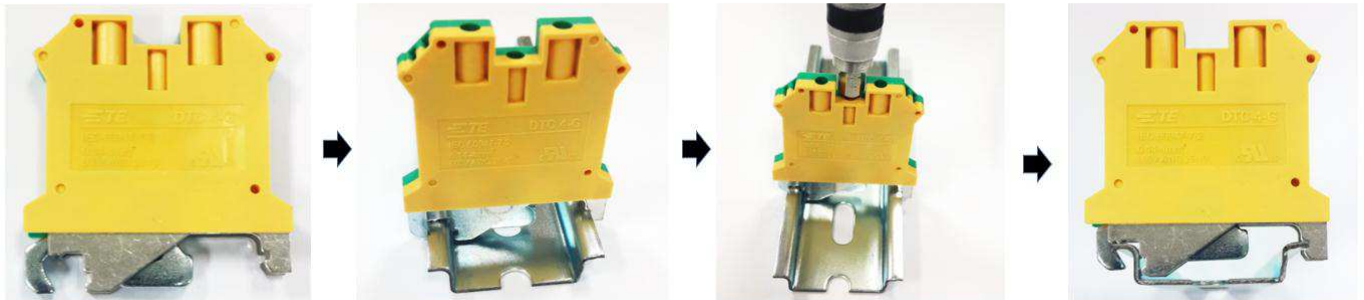

Figure 9.4 Protective conductor terminal block(with ground function) fixing to Din Rail

**B. Products removing from Din Rail.**

Removing terminal blocks from Din Rail, below instruction will help to operate it more conveniently and effectively.

For removing terminal block without ground function, use the applicable tool to insert into the groove of elastic latch and unclench it from the rail, detail see figure 10.1;

For removing protective conductor terminal block (with ground function), use the applicable tool to insert into the tool holes of product and loose the fixing screw , detail see figure 10.1;

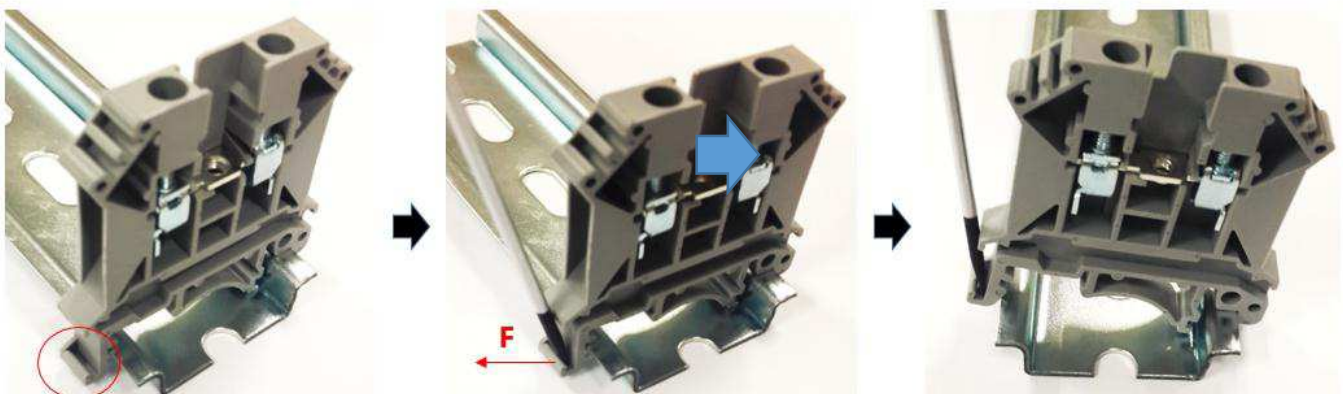

Figure 10.1 Product (without ground function) removing from Rail

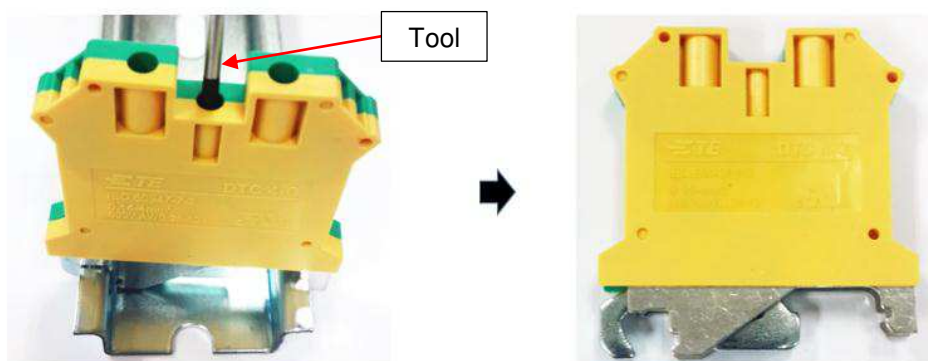

Figure 10.2 Product (with ground function) removing from Rail



**4.3 End block usage instruction**

**A. End block fixing to rail**

End block product has the function of limiting terminal block products on rail, makes them fixed on rail stably, and avoid the unnecessary movements of products. When user finish loading terminal blocks on rail, it should take end blocks to fixing on the each ends of rail leaning against the first and last product on rail (see figure 11)

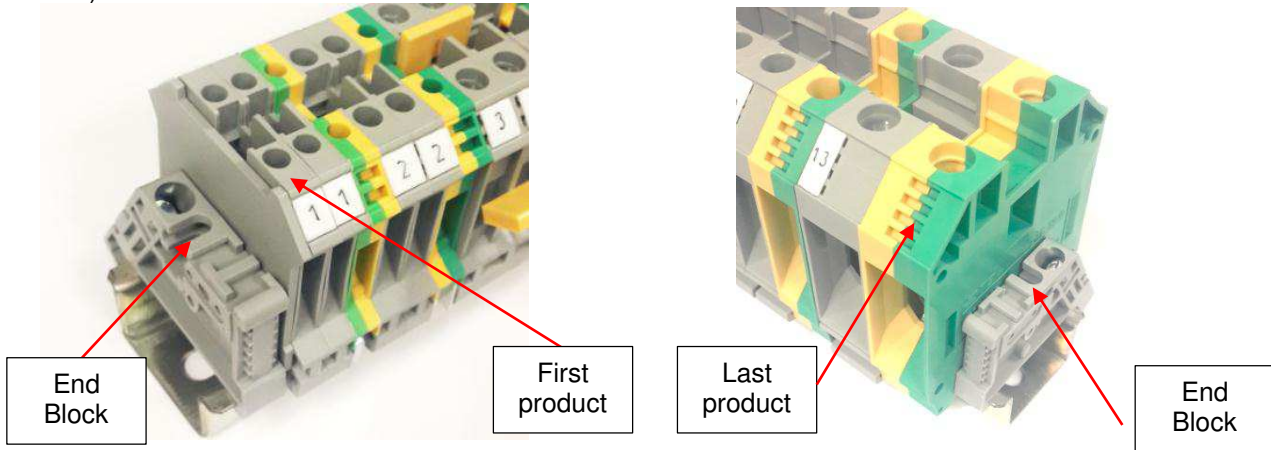

Figure 11

For end block, the fixing process of product to Din rail should follow below steps (see figure 12):

- 1>Inserting the rail edge into the lock space of end block latch.
- 2>using suitable tool to tighten the screw with the torque stated in customer drawing.

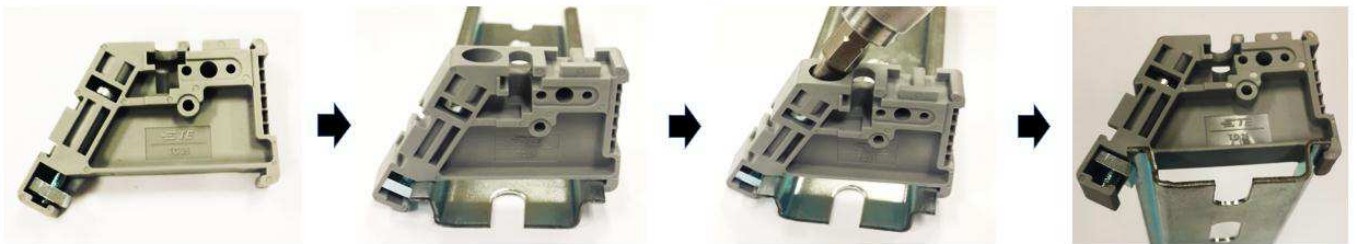

Figure 12 End block fixing to rail

**B. For end block removing from Din Rail, below instruction will help to operate it more conveniently and effectively.**

Using the applicable tool to loosen the screw and remove the end block from the rail, detail see figure 13:

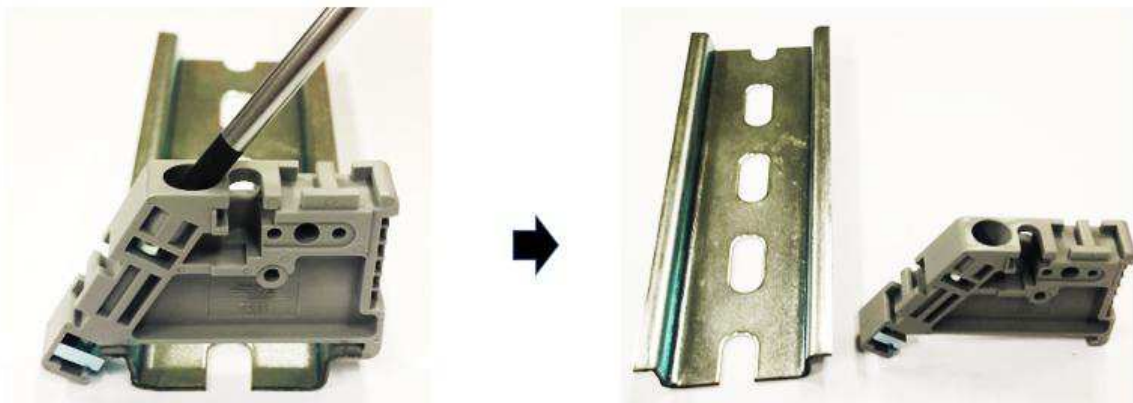

Figure 13 End block removing from Rail



#### 4.4 Plug bridge use instruction.

TE has many series plug bridge products, each series are applicable different terminal block products. Customer should refer to table 2 to select correct plug bridge for really application.

Table 2 Plug bridge

Plug Bridge Part Number	Plug Bridge Series	Continuous Current	Torque (Lbs-in)	Applicable Product Series (Wire section)
2271718-*	TFBC*-5	32/32A	3.5-6	2.5mm <sup>2</sup> series
2271719-*	TFBC*-6	41/32A	4.3-6	4mm <sup>2</sup> series
2271720-*	TFBC*-8	50/50A	4.3-6	6mm <sup>2</sup> series
2271721-*	TFBC*-10	57/57A	4.3-6	10mm <sup>2</sup> series
2271722-*	TFBC*-12	85/76A	10-15	16mm <sup>2</sup> series
2271723-*	TFBC*-16	138/112A	10-15	35mm <sup>2</sup> series

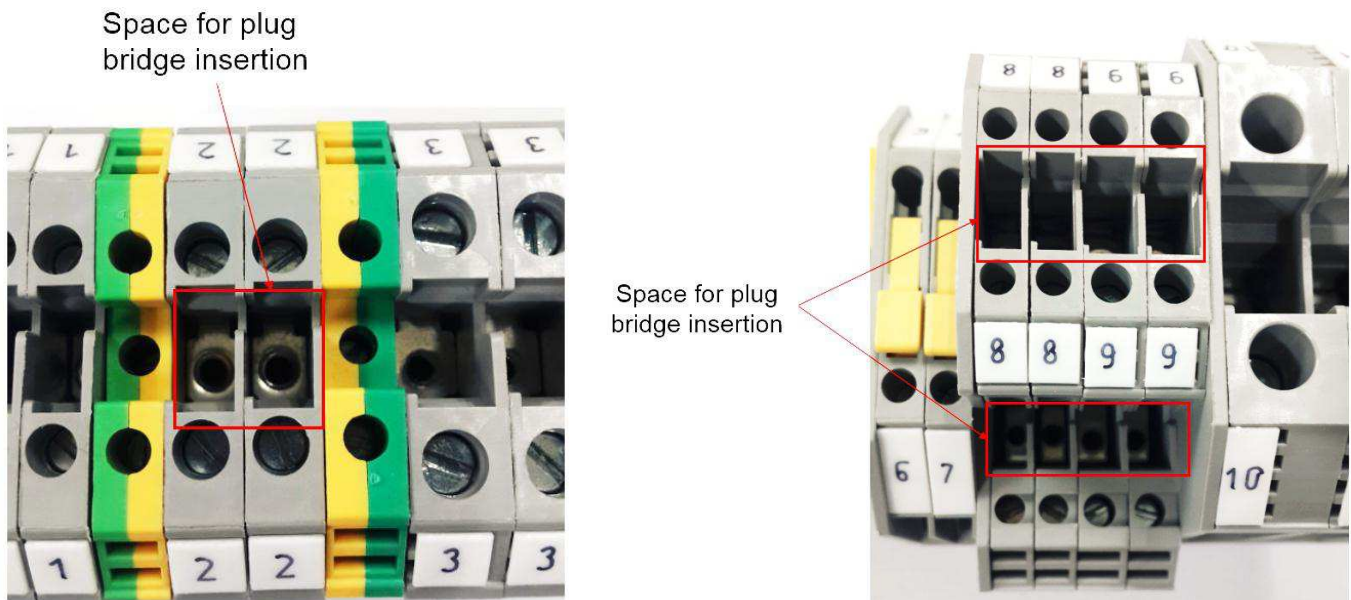

Figure 14.1 Hole of product for bridge insertion

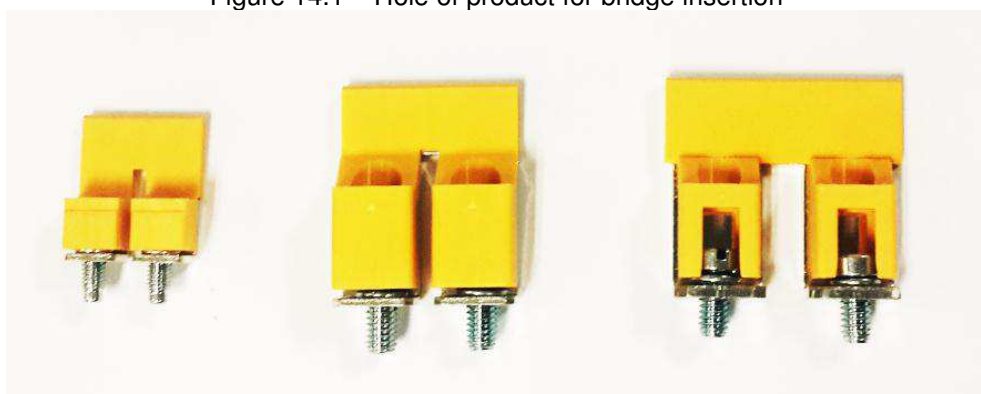
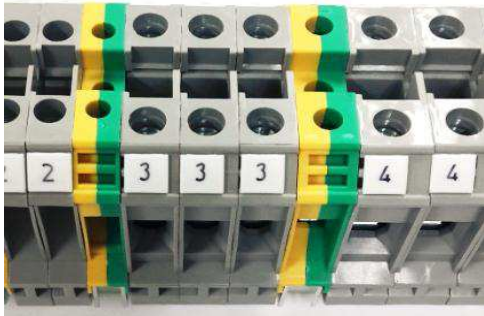

Figure 14.2 Plug Bridge

#### A. Plug Bridge fixing to product.

As shown on figure 14, each terminal block product have holes for plug bridge insertion, so if we selection the applicable plug bridge meeting the requirements, then insert the contact to two or more adjacent terminal block products following below steps to connect the related products together(See figure 15).

- 1> Select the plug bridge with two poles or more poles, ensure their electrical parameters are correct;
- 2> Inserting the plug bridge into the hole of terminal block which for plug bridge insertion;
- 3> Tighten the screw with the torque stated in customer drawing or table 2.



Step 1

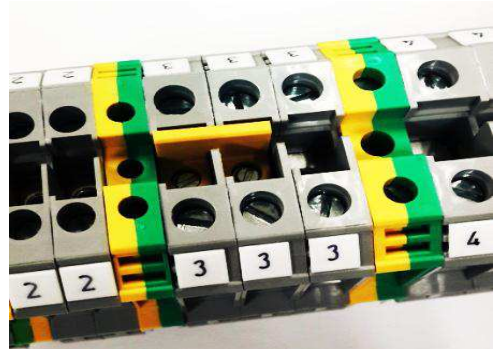

Step 2



Step 3

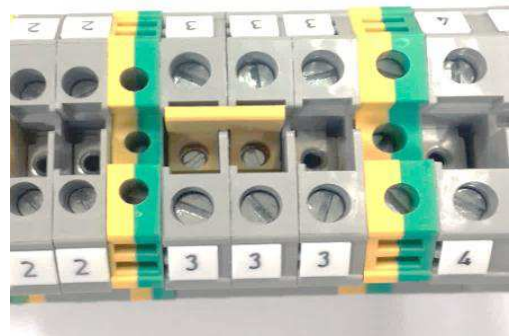

Figure 15

### B. Plug Bridge removing from product.

If the users need to remove the plug bridge from the products, it is necessary to use tools.

Taking appropriate tool and insert the hole of the plug bridge, loose the screw and then pull out the plug bridge from the product. (See figure 16).

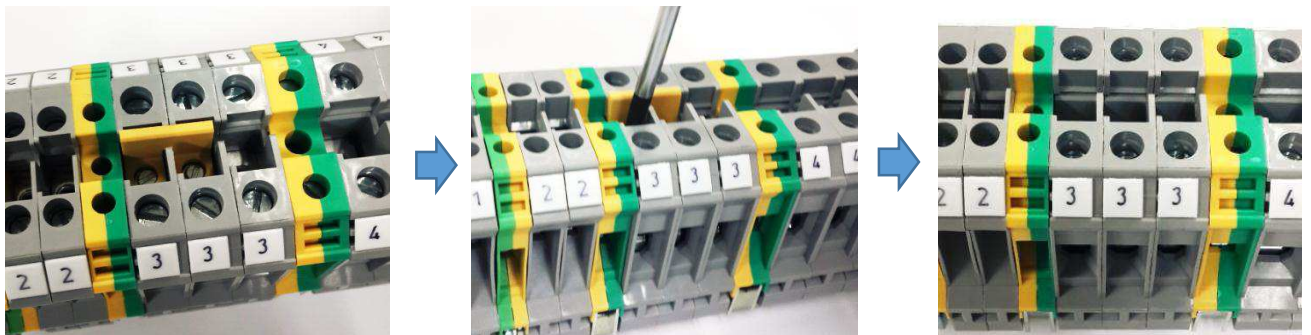

Figure 16 Plug Bridge removing

### 4.5 Side Plug Bridge use instruction.

TE has many series Side plug bridge products, each series are applicable different terminal block products. Customer should refer to table 3 to select correct plug bridge for really application.

Table 3 Side Plug Bridge

Plug Bridge Part Number	Plug Bridge Series	Continuous Current	Applicable Product Series (Wire section)
2271745-1	TFBCS 2-5	24/24A	2.5mm <sup>2</sup> series
2271746-1	TFBCS 2-6	32/32A	4mm <sup>2</sup> series
2271747-1	TFBCS 2-8	41/41A	6mm <sup>2</sup> series
2271748-1	TFBCS 2-10	57/57A	10mm <sup>2</sup> series

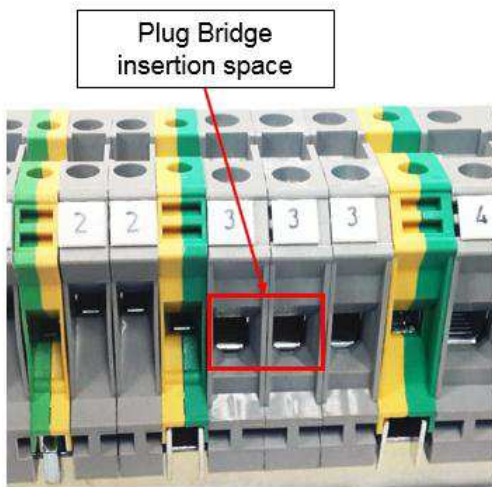

Figure 17.1 Plug bridge insertion space

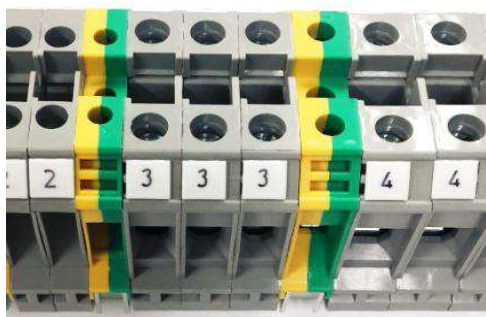

Figure 17.2 Side Plug Bridge

#### A. Plug Bridge fixing to product.

As shown on figure 17, each terminal block product have holes for side plug bridge insertion, so if we selection the applicable side plug bridge meeting the requirements, then insert the contact to two adjacent terminal block products following below steps to connect the related products together(See figure 18).

- a> Select the plug bridge with two poles or more poles, ensure their electrical parameters are correct;
- b> Inserting the plug bridge into the hole of terminal block which for plug bridge insertion;
- c> Tighten the screw with the torque stated in customer drawing for wire connection use proper screw-driver.



Step a

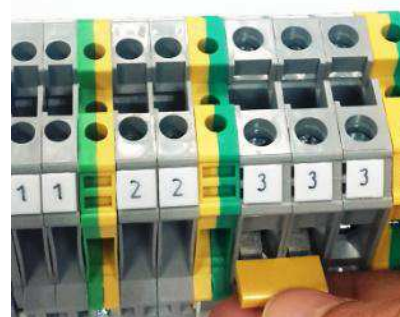

Step b



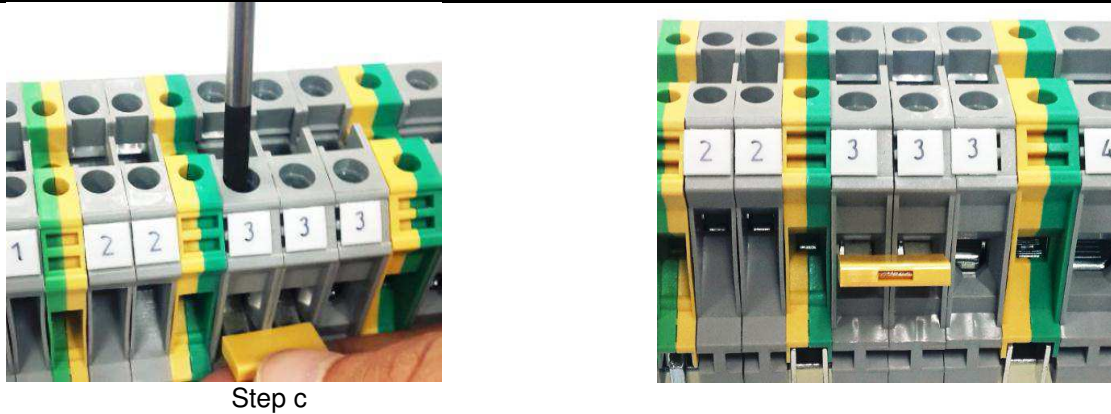

Figure 18

**B. Side Plug Bridge removing from product.**

If the users need to remove the plug bridge from the products, it is necessary to use screw-driver. Taking appropriate screw-driver and insert the hole of the terminal block, loose the screw and then pull out the Side plug bridge from the product. (See figure 19).

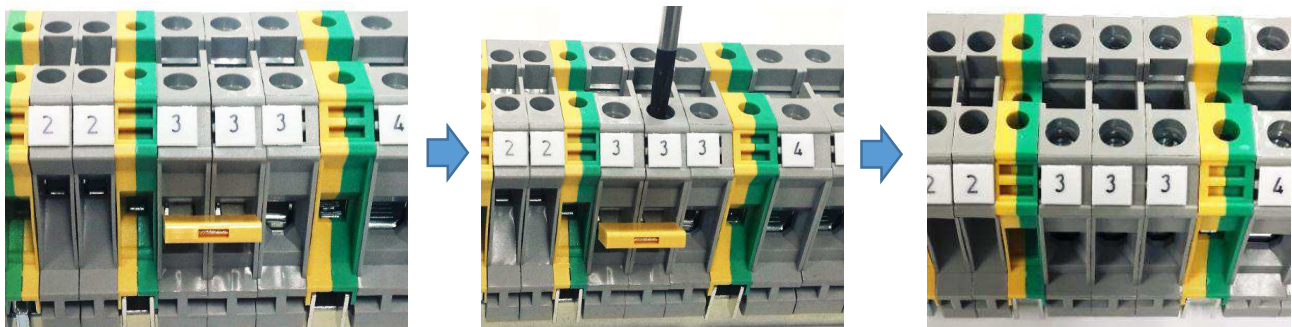
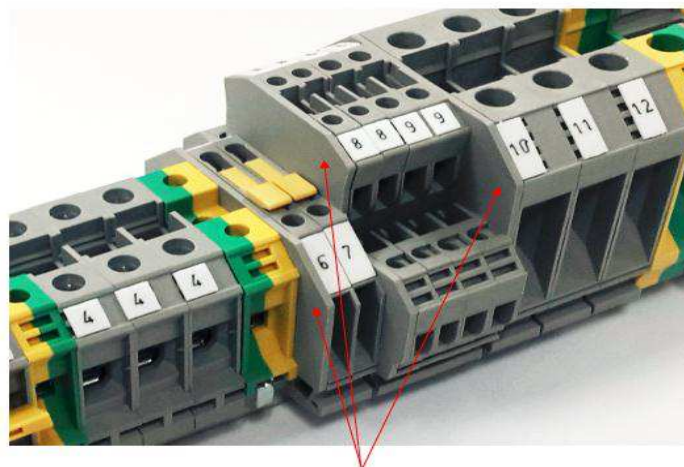

Figure 19 Plug Bridge removing

**4.6 End cover use instruction**

End cover provide insulation function and severance function for different series products on Din rail. Shown as below picture (figure 20):



End Cover

Figure 20



Cover mounting to product should make sure to press the posts or embossing of end cover into the holes or groove of terminal block product, detail shown as below (see figure 21):

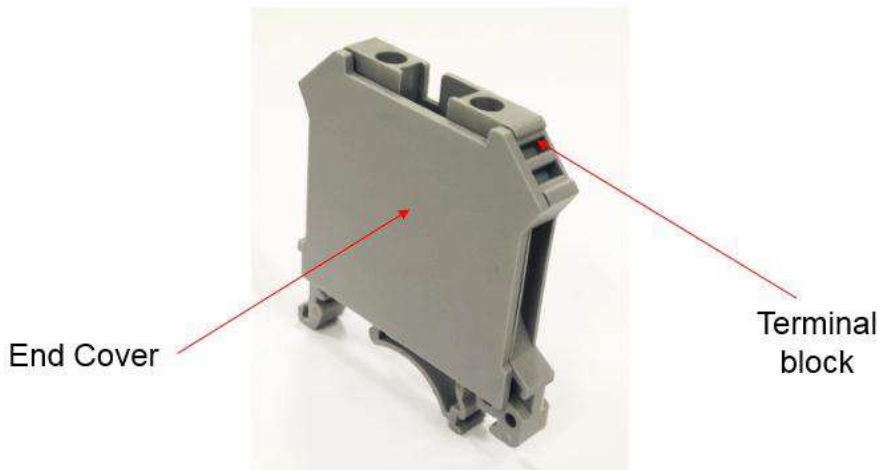
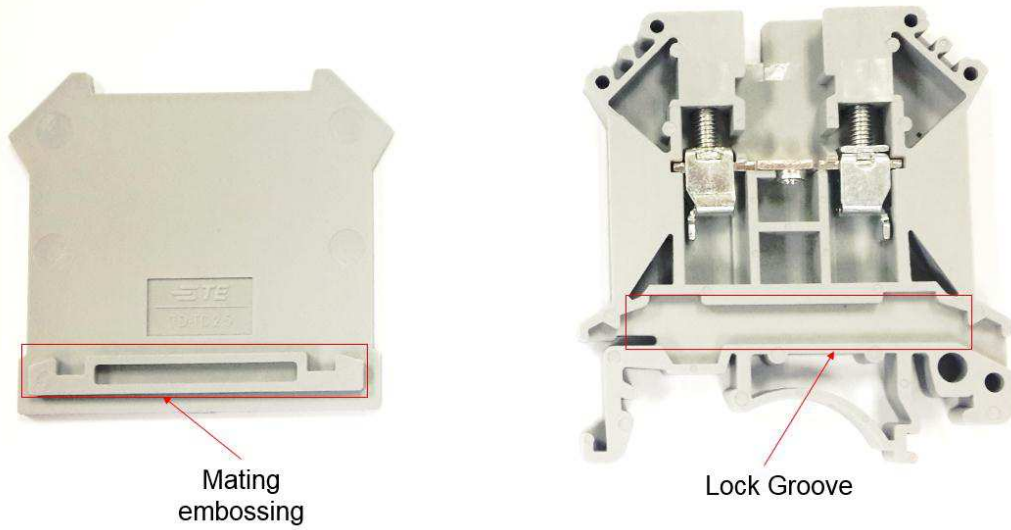
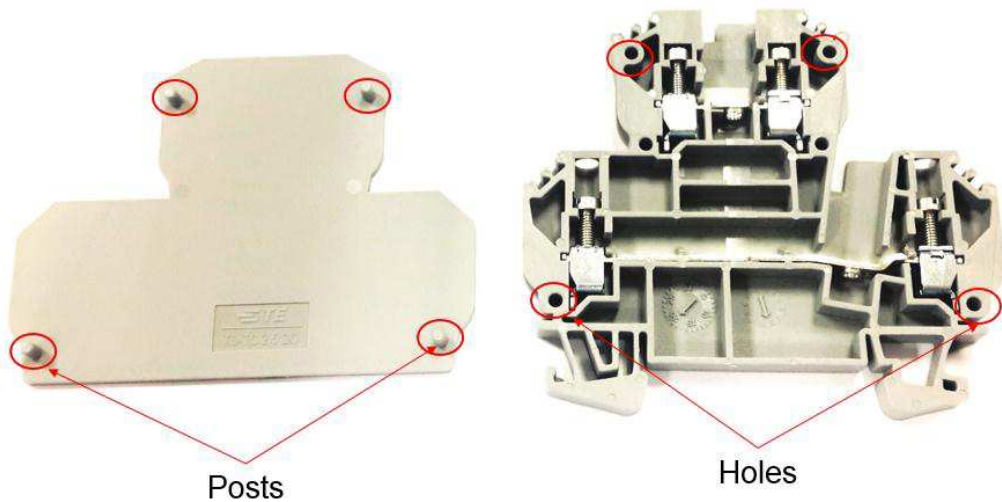

Figure 21.1



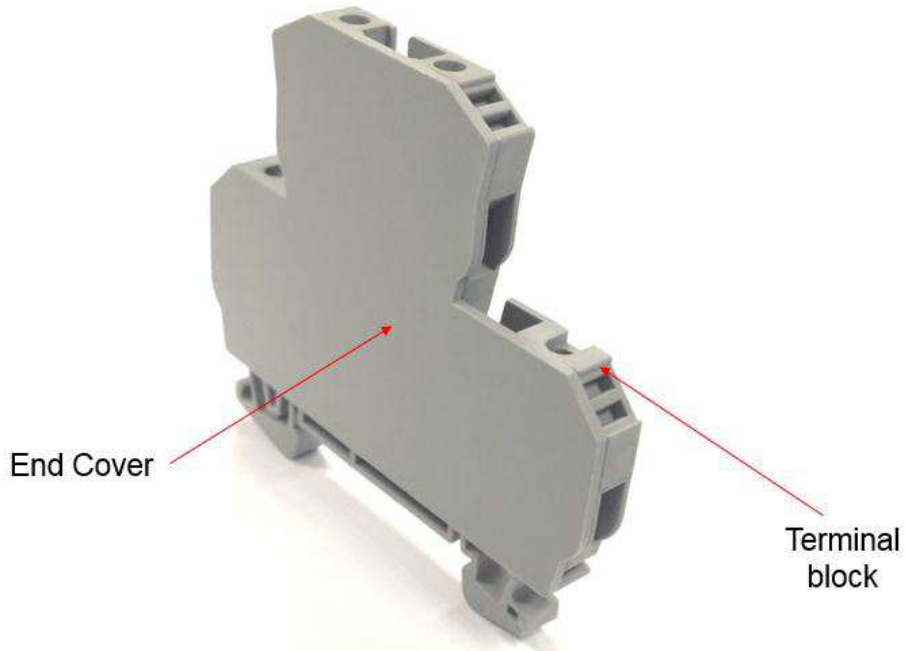

Figure 21.2

If need to separate the cover from the product, it is very easy to operate it. It only need to add a pull force on the correct area of end cover pointed as shown (see figure 22)

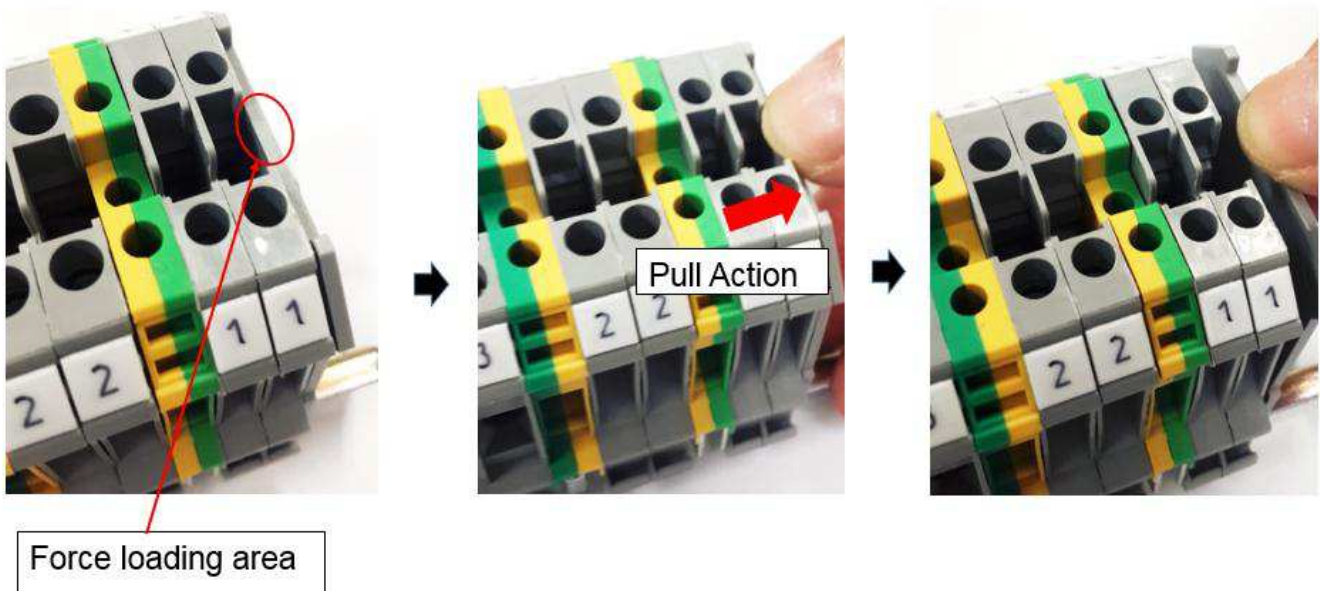

Figure 22 End Cover removing

#### 4.7 Label usage instruction

All the label should be selected following table 4 to ensure the labels meet the requirements of user. Before fixing to products, the label should finish printing the Arabic numerals or other comments needed using professional printer machine (see figure23).

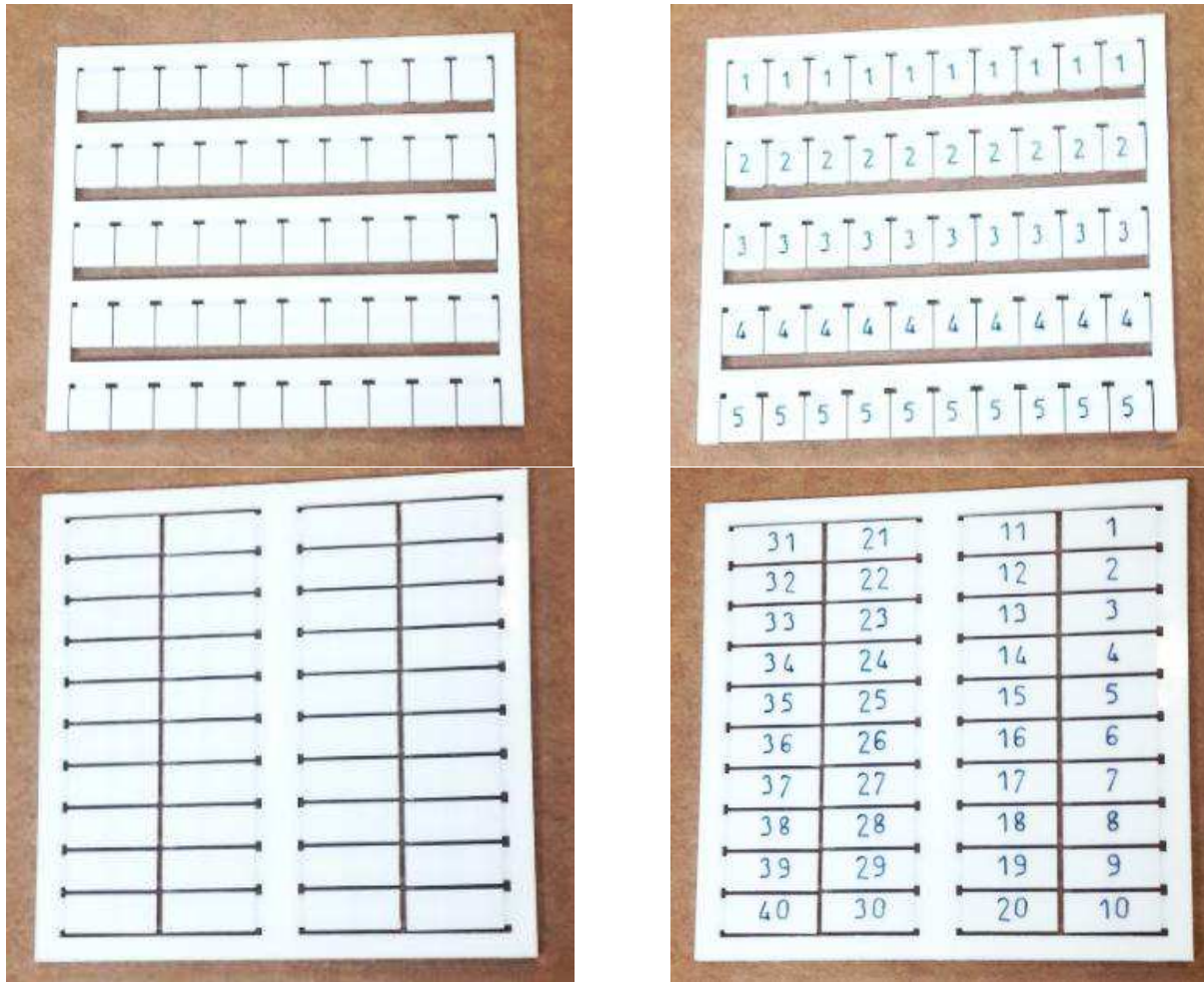

Figure 23 Label printing

**Table 4 Label List**

Type	TE Series	Applicable product series	Part Number
Label	TU-TM5	DTC 2.5*	2271724-1
	TU-TM6	DTC 4*, DTC 6*, DTC 10*	2271725-1
	TU-TM7	DTC 2.5 SW	2271726-1
	TU-TM8	DTC 16, DTC 16-G, DTC 35, DTC 35-G	2271727-1

After printing the required marking, take the suitable number of labels to fixing to the products. The latches of label must put into the groove of terminal block, detail see figure 24



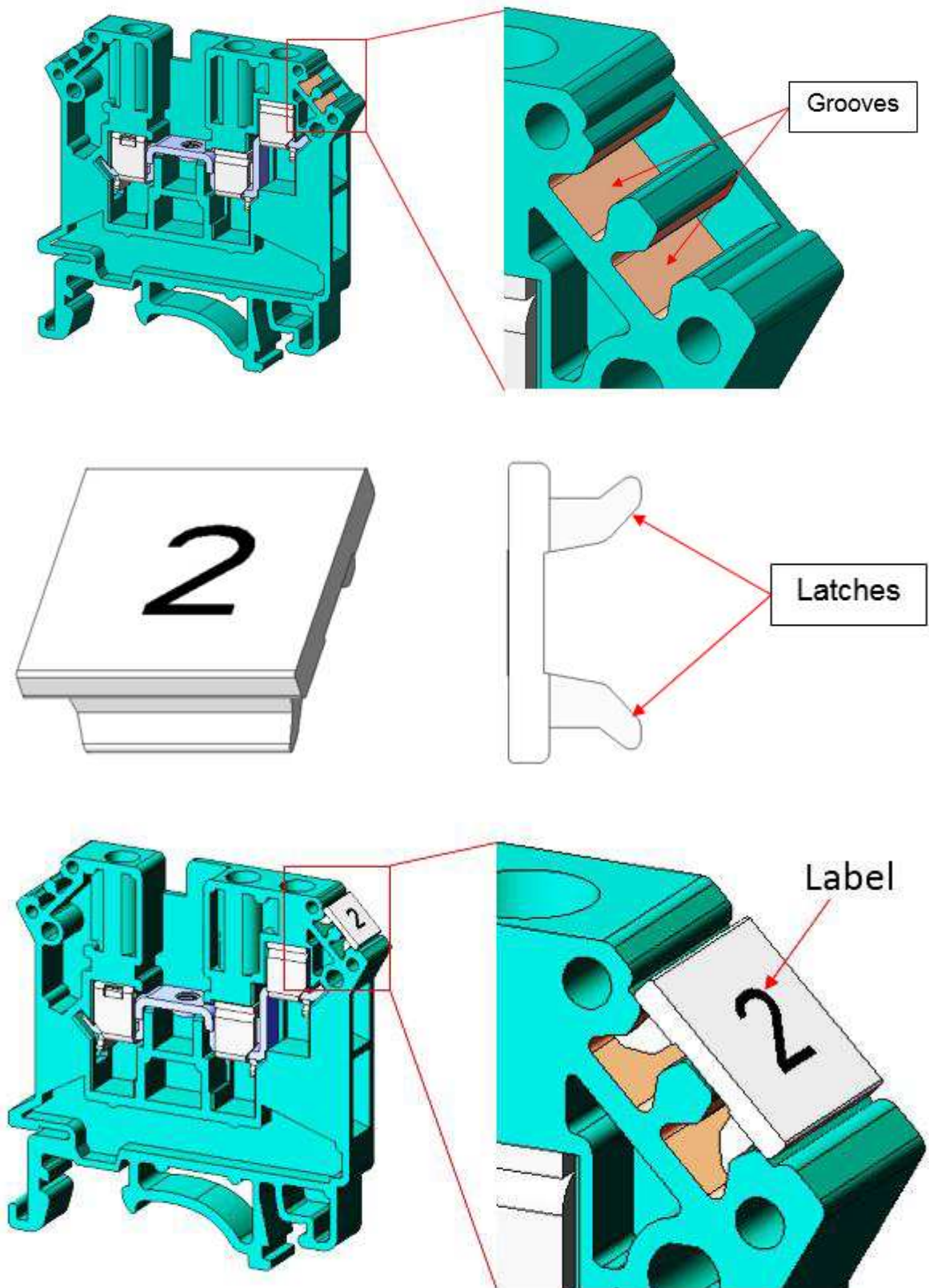

Figure 24 Label Fixing to product



**4.8 Fuse type screw terminal block usage instruction**

Fuse type terminal blocks have the same hole structures as other types terminal block connectors for wire insertion and connection, tooling insertion. follow 4.1 process to assemble wire and remove wire

Fuse type (with LED) terminal block is a special type terminal block. Its rated current should follow fuse's specification. Its rated Voltage should follow LED's specification, detail see the mark area shown in figure 25.

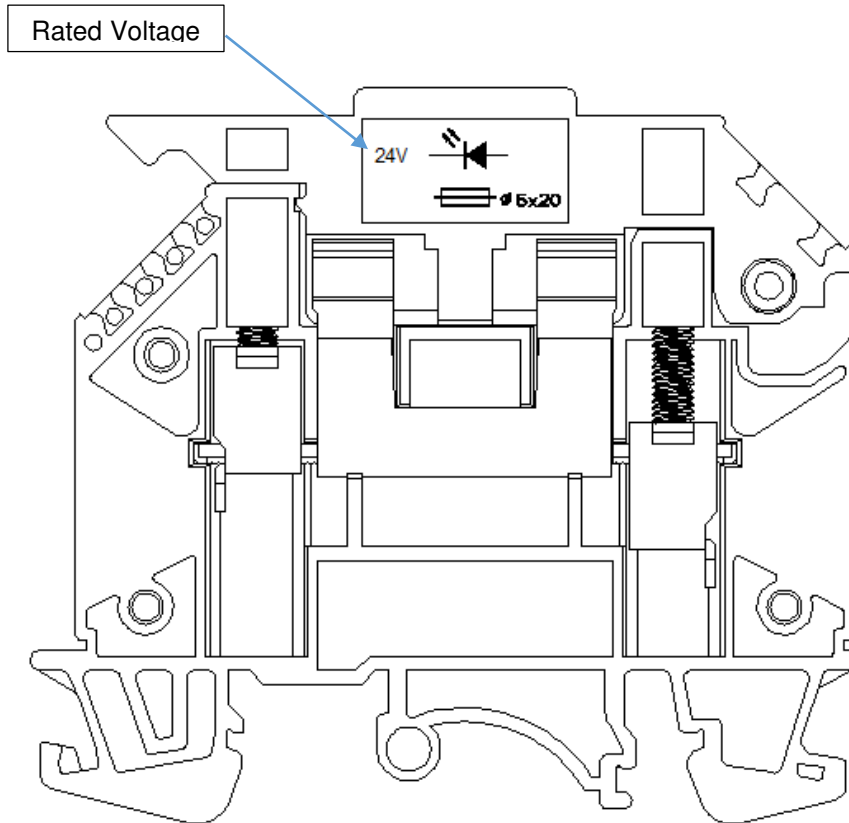
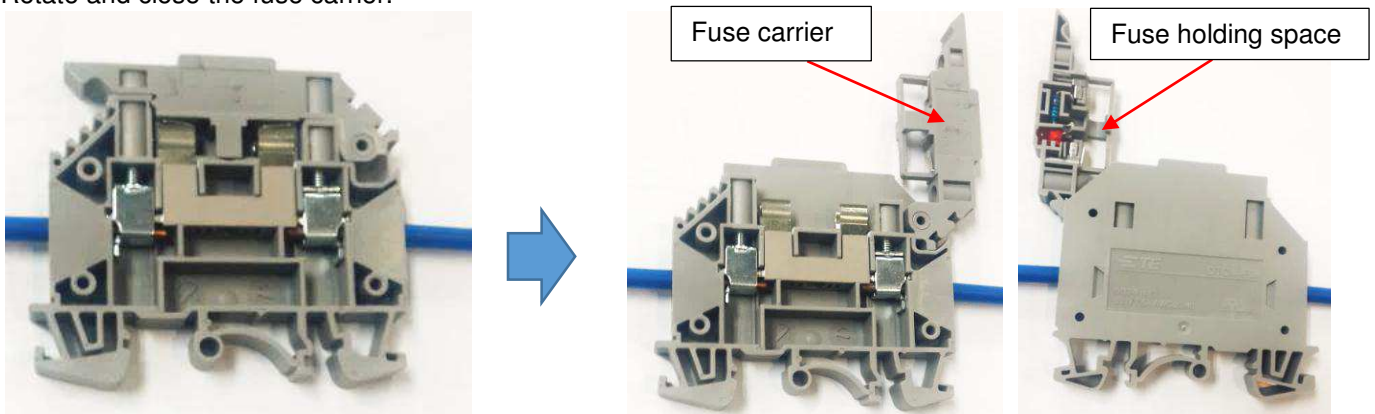

Figure 25

When customer using the fuse (G/5X20) to fix to product, below steps should be followed, detail see figure 25 for reference:

- 1> Rotate the fuse carrier and release the space for fuse insertion;
- 2> Insert the fuse into the space for holding the fuse of product
- 3> Rotate and close the fuse carrier.



Step 1

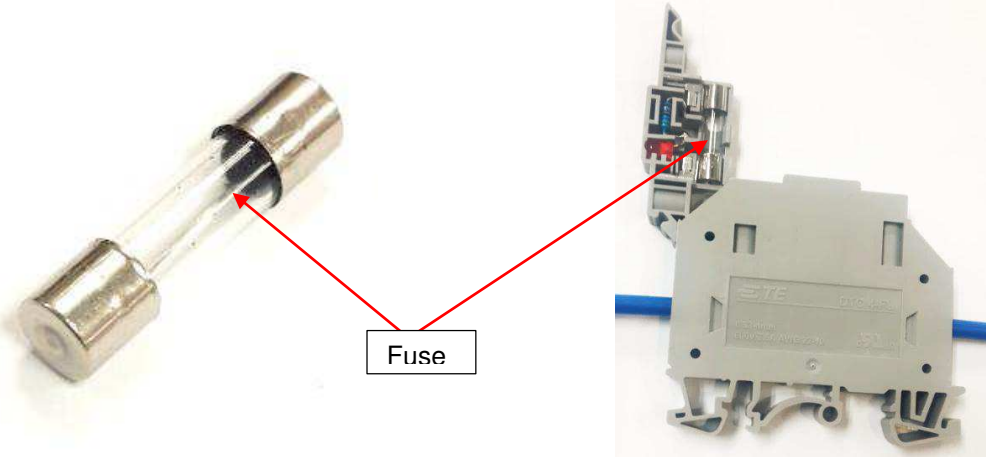

Step 2

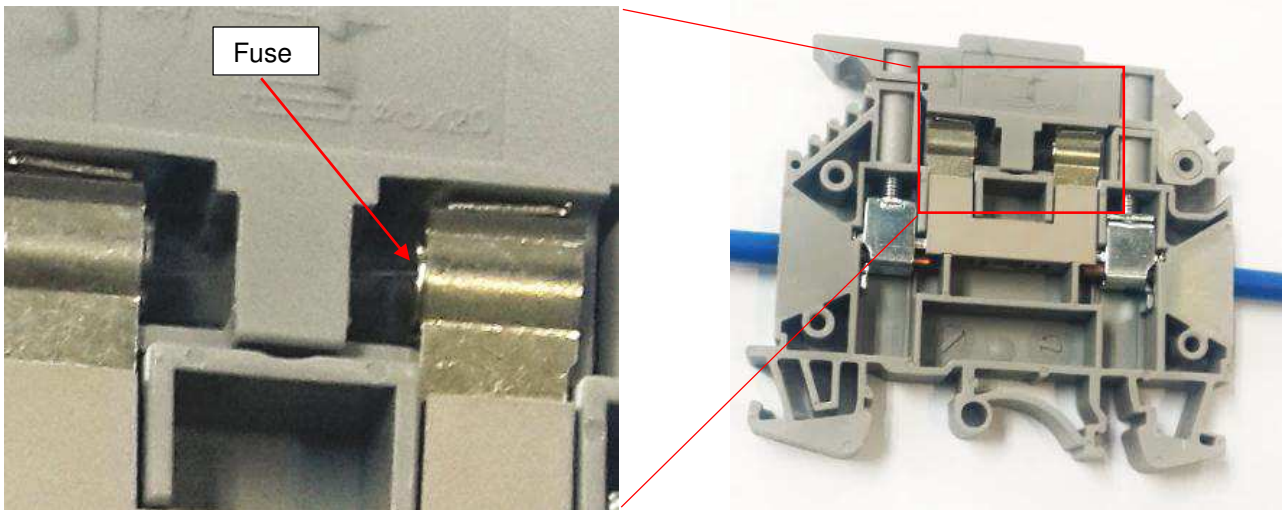

Step 3

Figure 26 Fuse Assembly

**4.9 DTC 6-EL usage instruction:**

Current test terminal block DTC 6-EL has the same hole structures as other types terminal block connectors for wire insertion and connection, tooling insertion, follow 4.1 process to assemble wire and remove wire (see figure 27)

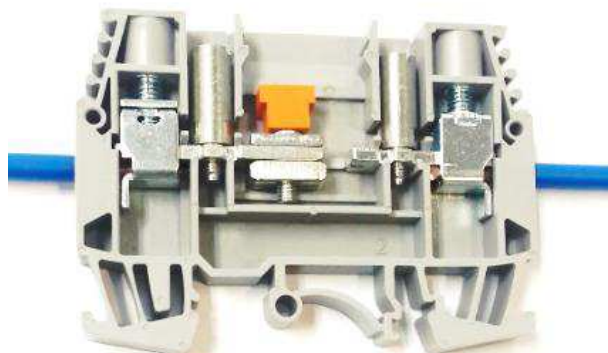
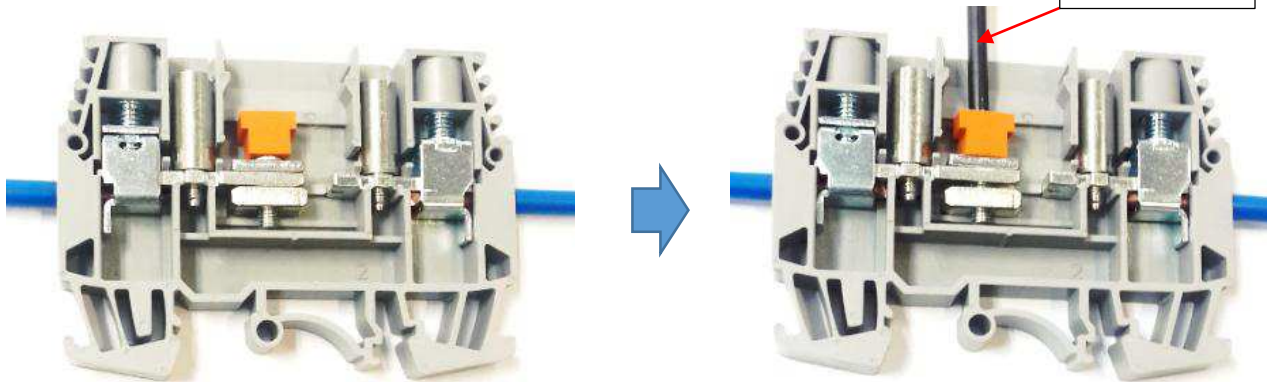

Figure 27 wire connection

When need to connect the circuit, the disconnect unit should be operated follow below steps(figure 28):

- 1> Loose the screw of disconnect unit
- 2> Move the disconnect unit to right side
- 3> Tighten the screw with stated torque to ensure the connection reliability.

Screw driver



Step 1

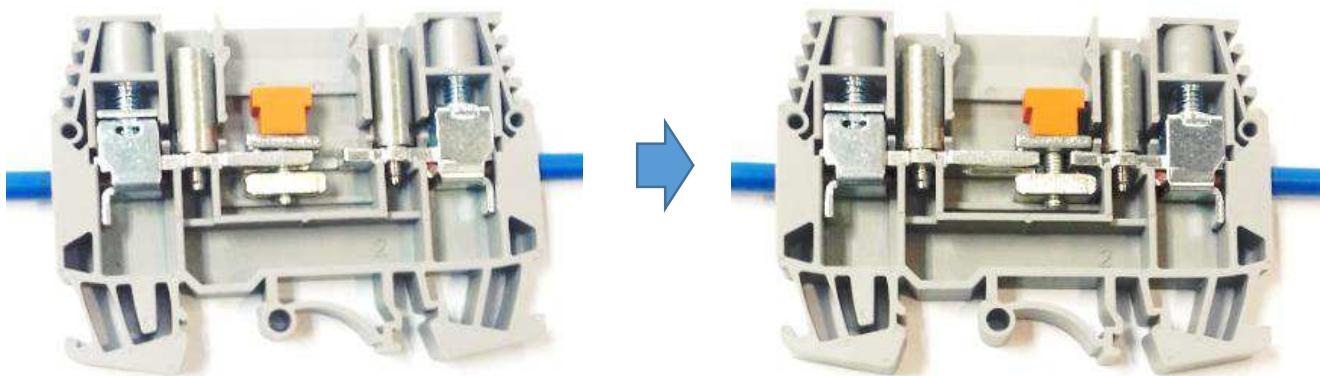

Step 2

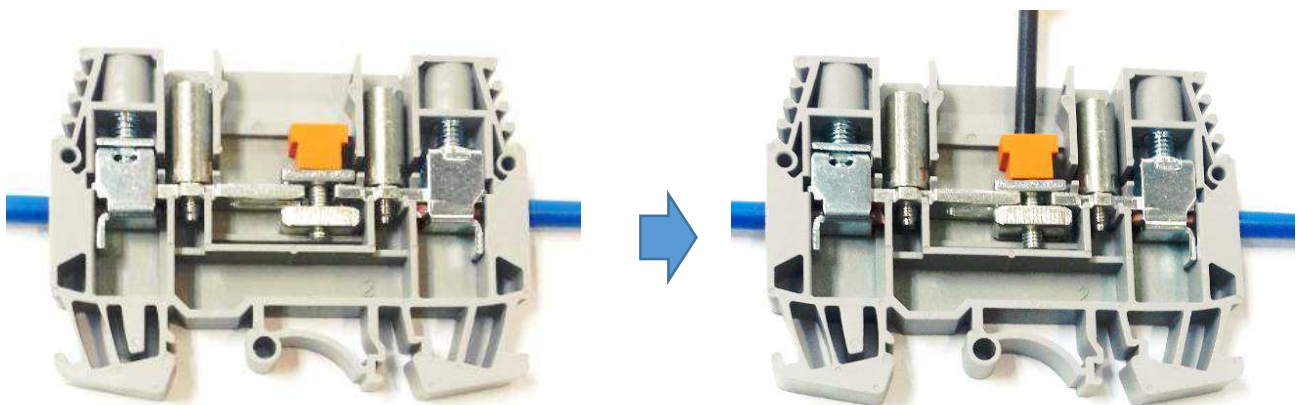

Step 3  
Figure 28

If need to disconnect the circuit, user should reverse the above process to operate.



Consideration must be given to toxicity and other safety requirements recommended by the solvent manufacturer. Refer to the manufacturer's Material Safety Data Sheet (MSDS) for characteristics and handling of cleaners. Trichloroethylene and Methylene Chloride can be used with no harmful affecting to the connectors; however TE does not recommend them because of the harmful occupational and environmental effects. Both are carcinogenic (cancer-causing) and Trichloroethylene is harmful to the earth's ozone layer.