

CODINGS
Kodierungen
2:1

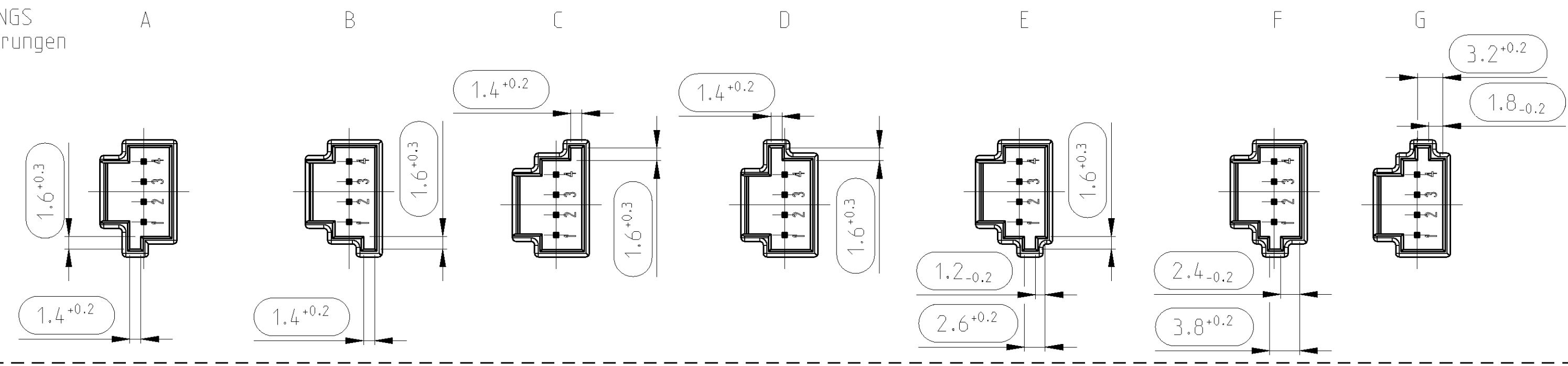

| LOC | DIST | REV | DATE | DWN | APVD |
|-----|------|-----|-----------|-----|------|
| A1 | - | 1 | 08JUL2010 | SBL | HHC |

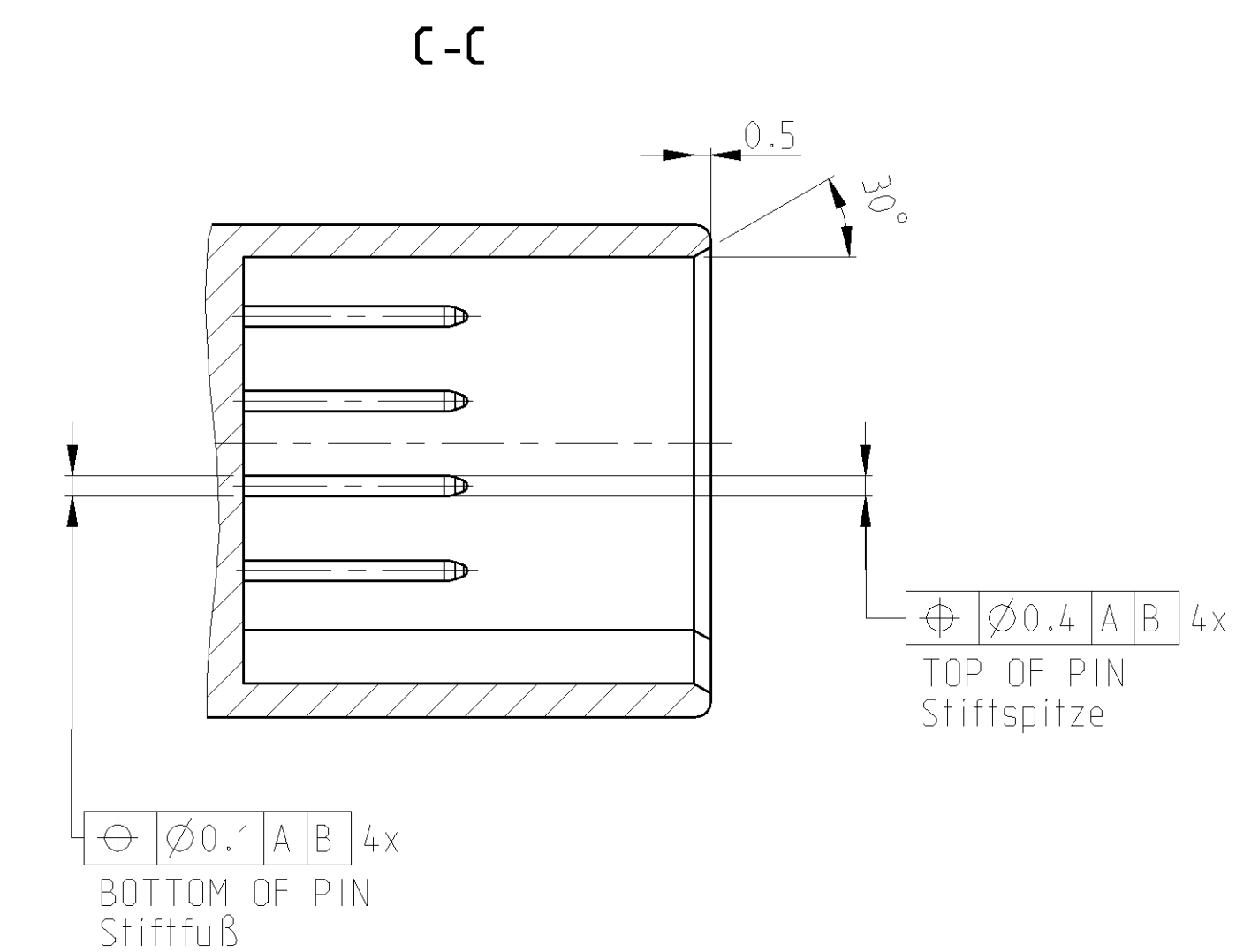
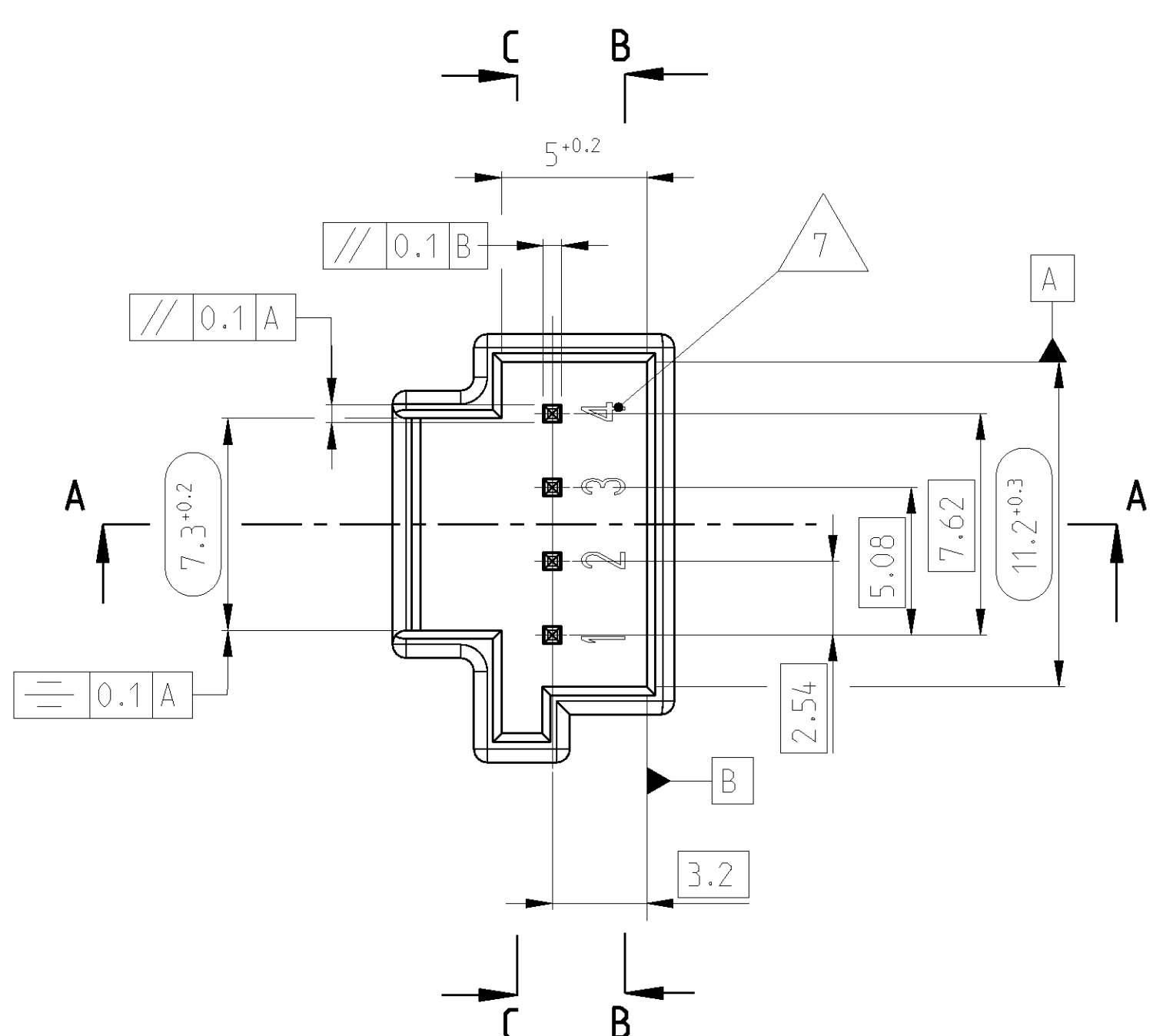
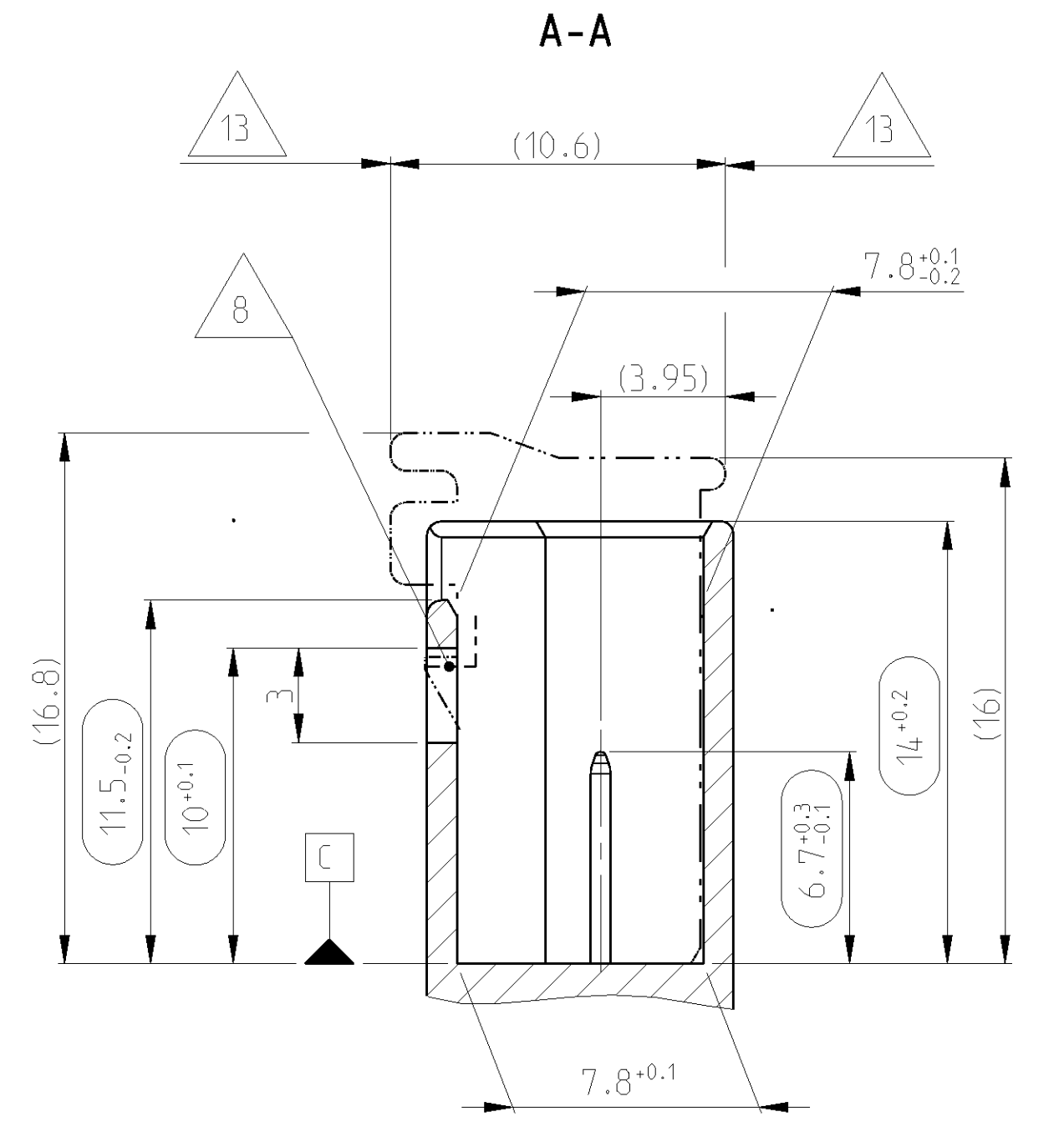

- NOTES:**
Bemerkungen
- ONLY THE GERMAN LANGUAGE VERSION IS AUTHORITATIVE
Massgebend ist nur der deutsche Text
 - CODING A AS SHOWN
Kodierung A wie gezeichnet
 - REFERENCES [A],[B], FOR CENTERLINE DEFINITION
1 mm ABOVE REFERENCE [C]
Bezugslinien [A],[B], zur Ermittlung der Mittellinien
1 mm ueber Bezug [C] definieren
 - FUNCTIONAL MEASUREMENTS
Funktionsbestimmende Masse
 - ALL SYMMETRIC DIMENSIONS
Alle Symmetriemasse
 - NO SPECIFIED RADII R0.5 mm
Unbemaste Radien R0.5 mm
 - CAVITY MARKING, CHARACTERS DEEP
(CHARACTERS SIZE AFTER CHOISE OF THE MANUFACTURER)
Kammer Nummern, Schrift vertieft
(Schifthoehe nach Wahl des Herstellers)
 - IN THIS AREA MAX. 0.03MM BURRS PERMITTED
in diesem Bereich max. 0.03mm Grat zulaessig
 - AREA FOR SURFACE PLATING Au SEE SPECIFICATION OF CONTACT PIN
Bereich fuer Oberflaeche Au siehe AV fuer Kontaktstift
 - MAX. DEPTH IN THE FRONT PLATE OF THE UNIT
Max. Versenkungstiefe in der Frontplatte des Aggregates
 - THE USED MATERIAL IS TO BE SELECTED IN SUCH A WAY THAT
THE REQUIRED MECHANICAL AND ELECTRICAL CHARACTERISTICS ARE FULFILLED
ACCORDING TO THE VALID DESIGN GUIDELINES AND SPECIFICATIONS.
Das verwendete Material ist so auszuwaehlen dass die geforderten
mechanischen und elektrischen Eigenschaften nach den gueltigen
Konstruktionsrichtlinien und Spezifikation eingehalten werden.
 - NO SPECIFIED WALL THICKNESS MIN. 1 MM
Unbemaste Wandstaerken min. 1 mm
 - SPACE OF ACTIVITY MIN 15MM
Betaetigungsfreiraum min. 15mm

| NOTE | FEATURE | Tyco Electronics - No. |
|------|--|------------------------|
| 14 | INTERFACE DRAWING CONTACT PIN Ausfuehrungsvorschrift Kontaktstift | 114-18063, Typ A or B |

| | | | |
|---|--|---|---|
| <p>THIS DRAWING IS UNPUBLISHED. RELEASED FOR PUBLICATION BY TYPED ELECTRONICS CORPORATION. ALL RIGHTS RESERVED. COPYRIGHT 2008 BY TYPED ELECTRONICS CORPORATION. ALL RIGHTS RESERVED.</p> | | <p>DWN: S. Bludan 24MAR2010</p> <p>CHK: H. Holland-Cuduz 24MAR2010</p> | <p>Tyco Electronics Tyco Electronics AMP GmbH 64625 Bensheim (Germany)</p> |
| <p>PRODUCT SPEC: -</p> <p>APPLICATION SPEC: -</p> | | <p>NAME: -</p> <p>SIZE: A1</p> <p>CASE CODE: 00779</p> <p>DRAWING NO: 114-18063-169</p> | <p>RESTRICTED TO NEW FLEX: -</p> <p>SCALE: 5:1</p> <p>SHEET: 1 OF 1</p> <p>REV: A</p> |