















Ausfuehrung / VERSION		ELO Buchsen- und Stiftkontakt / ELO SOCKET- AND PIN TERMINAL									
Querschnitt CROSS SECTION	(mm ²)	0.22	0.35	0.5	0.6	0.75					
Leitungsdurchmesser FLR (Leitung mit red. Isolierung) WIRE DIAMETER FLR (WIRE WITH THIN INSULATION)	(mm)	1.2 -0.1	1.4 -0.2	1.6 -0.2	1.8 +0.10 -0.05	1.9 -0.2					
Leitungsdurchmesser FLU (Leitung mit ultradünnen Isolierung)  WIRE DIAMETER FLU (WIRE WITH ULTRA THIN INSULATION)		-	1.2 -0.1	1.4 -0.1	-	-					
ELO Kontakt ELO TERMINAL TE	Buchsenkontakt SOCKET TERMINAL	*-1411550-* / *-1411552-* / *-1411558-* *-1411560-* / *-1411566-* / *-1411574-* / *-1411576-*				*-1411551-* / *-1411553-* / *-1411561-* *-1411567-* / *-1411575-*					
	Stiftkontakt / PIN TERMINAL	*-1411580-* / *-1411582-*									
	Adercrimp WIRE CRIMP Schnitt A-A SECTION A-A	Mass H DIM. H (mm) 	0.87 ±0.03	0.92±0.03		1.0±0.03		1.11 ±0.03	1.05±0.03	1.17 ±0.03	1.15±0.03
		Mass W DIM. W (mm) 	1.40 F	1.40 F 	1.47±0.03 	1.40 F 	1.47±0.03 	1.57 F 	1.76±0.03 	1.57 F 	1.76±0.03 
	Isolationscrimp INSUL. CRIMP Schnitt B-B SECTION B-B	Auszugskr. n. DIN EN 60352-2 EXT. FORCE ACC. TO DIN EN 60352-2	>=30N	>=50N		>=60N		>=70N		>=80N	
		Mass X DIM. X FLR (mm) 	1.4 ±0.1	1.5 ±0.1		1.75 ±0.1		2.0 ±0.1 			
Mass X DIM. X FLU (mm) 		-	1.4 ±0.1		1.55 ±0.1		-				
Werkzeug TOOL TE	Crimp-Schnell- wechsel- werkzeug APPLICATOR	Applicator TE	2151153-X (1528284-X) (9-0541100-X)				2151877-X (1528290-X) (9-0541101-X)				
		frueher Siemens EC FORMER SIEMENS EC	V23599-E5004-C4				V23599-E5004-C11				
	Crimp-Handzange HAND TOOL		5-1393462-3				5-1393462-2				

Masse ohne Toleranzangabe sind Richtmasse
DIMENSIONS WITHOUT TOLERANCE ARE PROPOSUAL

THIS INFORMATION IS CONFIDENTIAL AND YOU MAY NOT DISCLOSE IT TO OTHERS WITHOUT WRITTEN AUTHORIZATION FROM AMP INCORPORATED, HARRISBURG, PA

LOC
AI
DIST

Schneidueberstand
CUT OFF LENGTH
dargestellt / SHOWN *-1411580-*

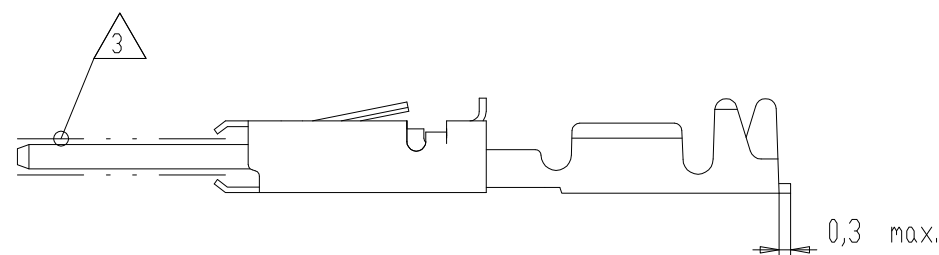

Absolierlaenge
STRIPPING LENGTH

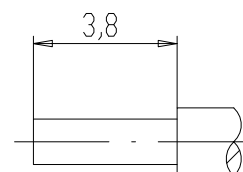

Crimpgeometrie
CRIMP GEOMETRIE
dargestellt / SHOWN *-1411552-*

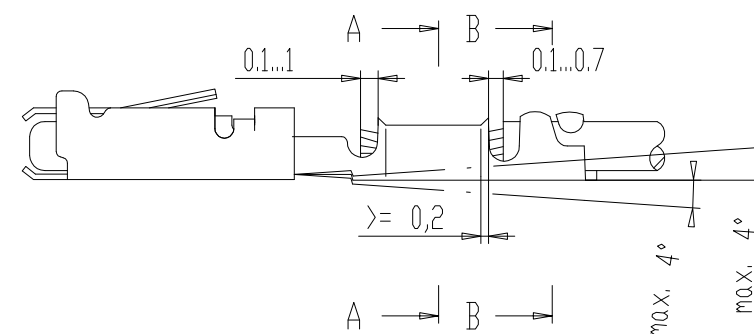

Schnitt A-A
SECTION A-A

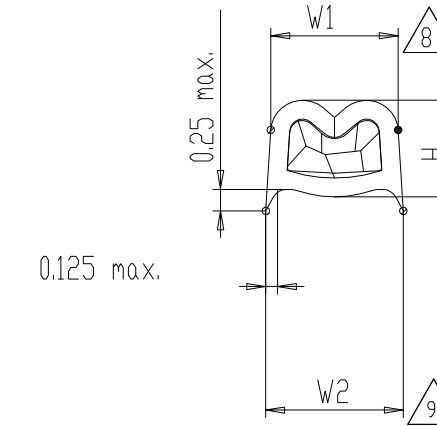



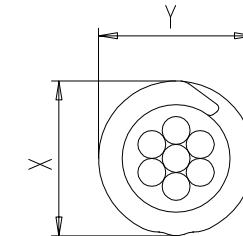



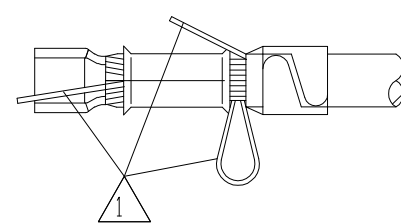



Schnitt B-B
SECTION B-B



Nicht zulaessig:
NOT PERMISSIBLE:



-  Draehnte ausserhalb der Crimpung
STRANDS OUTSIDE CRIMP
-  Fehlen einzelner Draehnte
MISSING OF INDIVIDUAL STRANDS
-  Stift nicht mit blosser Hand beruehren
DO NOT TOUCH PIN WITH BARE HAND
-  fuer Handzange ±0.04 Tol.
FOR HAND CRIMPING TOOL ±0.04 TOL.
-  fuer Handzange ±0.06 Tol.
FOR HAND TOOL ±0.06 TOL.
-  nach Spezifikation 114-18022
ACCORDING TO SPECIFICATION 114-18022
-  fuer seitlich polarisierte Kontakte Mass X max. 2.05
POLARIZATION ON SIDE, CONTACTS DIM. X MAX. 2.05

-  theoretische Crimpbreite W1
THEORETICAL CRIMP WIDTH W1
-  messbare Crimpbreite W2
MEASURABLE CRIMP WIDTH W2
-  FLU-Leitungen nur fuer PN 0-1411574-2
und *-1411566-* freigegeben
FLU WIRES RELEASED FOR PN 0-1411574-2
AND *-1411566-* ONLY

P	LTR	REVISION RECORD	DATE	DVN	APVD
A8	FLU WIRE ADDED		01SEP2015	Moh.	Leim.
A7	OCEAN APPLICATOR ADDED		25FEB2013	Leiming	Goep
A6	NOTE *-1411576-* ADDED		16.06.09	Meyer	Goep
A5	HDI APPLICATOR AND NOTE 7 ADDED		03.07.08	Abr	Goep

DIMENSIONS		TOLERANCES UNLESS OTHERWISE SPECIFIED	
MM		0 PLC	± -
		1 PLC	± -
		2 PLC	± -
		3 PLC	± -
		4 PLC	± -
ANGLES ± 1°			
SURFACE TEXTURE		-	

DVN	24.04.03	MATERIAL	-	HEAT TREAT	-
G.Abraham					
CHK	25.04.03				
C.Göppel					
APVD	25.04.03				
M.Bleicher					
NAME: Verarbeitungsanweisung / WORKING INSTRUCTIONS ELO Crimpkontakte / ELO CRIMP TERMINALS					
SCALE	SIZE	DRAWING NO	SHEET	OF	REV
-	A2	114-18433	1	1	A8

