

LOC	DIST	REV	DESCRIPTION	DATE	BY	APPV
A1	-	A	NEW DRAWING	12.JUN2002	NEB	-
		A1	CODING TABS CHANGED. WAS EGAUTO2109-002	09.JUL2002	NEB	-
		A2	NOTE CHANGED. DC-NO. ADDED	18.JUL2002	DME	-

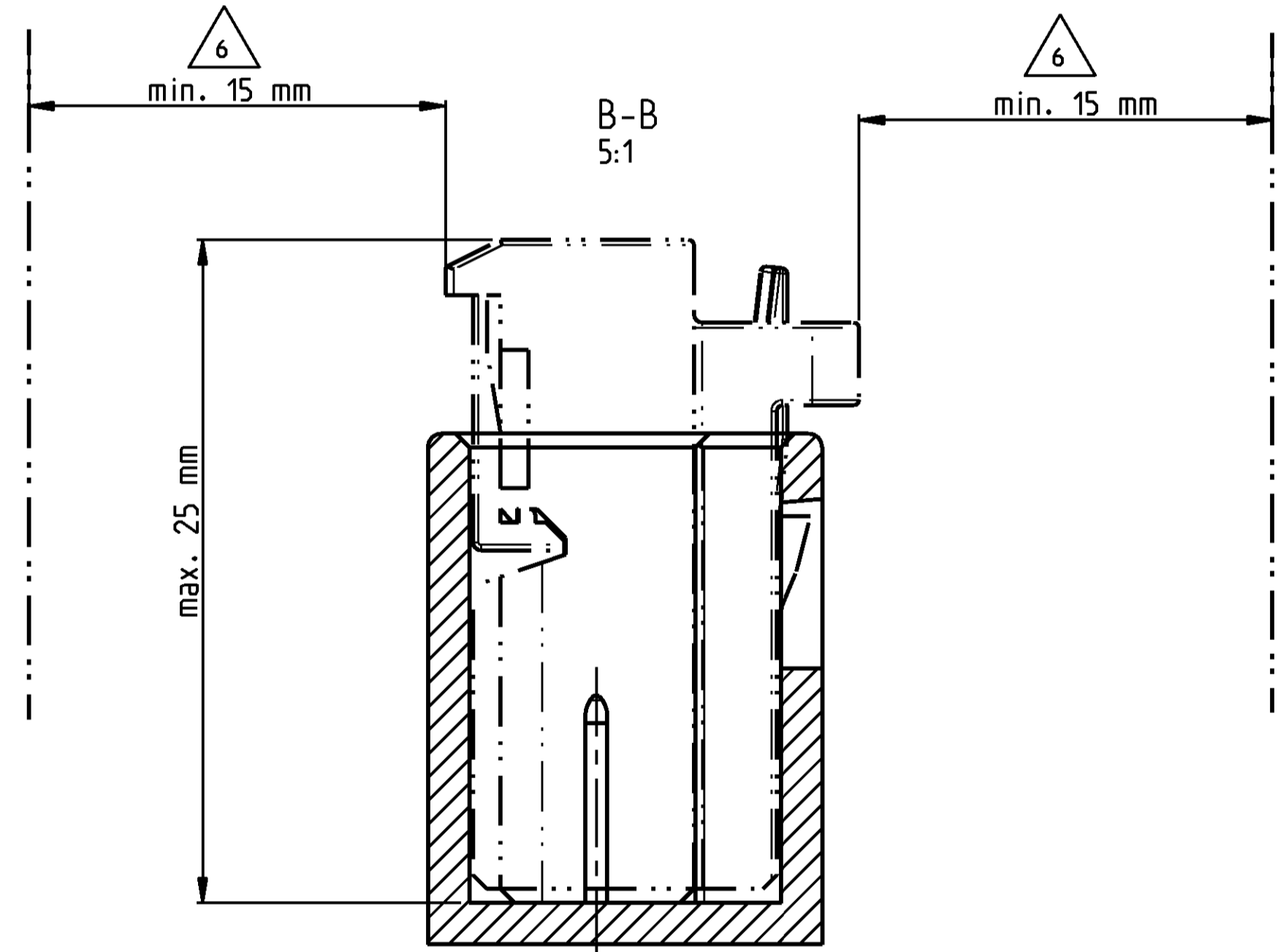

- NOTES  
Bemerkungen
- ACCORDING TO SOCKET HOUSING (2POS)  
SEE DRAWING. TYCO NO.: 1418506  
DC NO.: A048 545 62 28  
Passend zu TB Kupplung (2fach)  
siehe Zeichnung. Tyco No.: 1418506  
DC-Nr.: A048 545 62 28
  - MARKING DEEP  
Schrift vertieft
  - IN THIS AREA MAX. 0.03MM BURRS PERMITTED  
In diesem Bereich max. 0.03mm Grat zulässig
  - NOT SPECIFIED RADIUS R0.5  
Unbenannte Radien R0.5
  - NOT SPECIFIED WALL THICKNESS MIN. 1.3 MM  
Unbenannte Wandstärken min. 1.3 mm
  - SPACE OF ACTIVITY  
Betätigungsfreiraum
  - POSITION TOLERANCE OF THE RELATION LAYER  
[A] AND [B] MEASURED AT THE BOTTOM OF THE PIN HEADER  
Bezugslinie für Positionstoleranz  
[A] und [B] am Grund der Stiftwanne
  - ONLY THE GERMAN LANGUAGE SHALL BE BINDING  
Maßgebend ist der deutsche Text
  - MAX. SINKING DEPTH IN THE FRONT PLATE OF THE UNIT  
Max. Versenkungstiefe in der Frontplatte  
des Aggregates

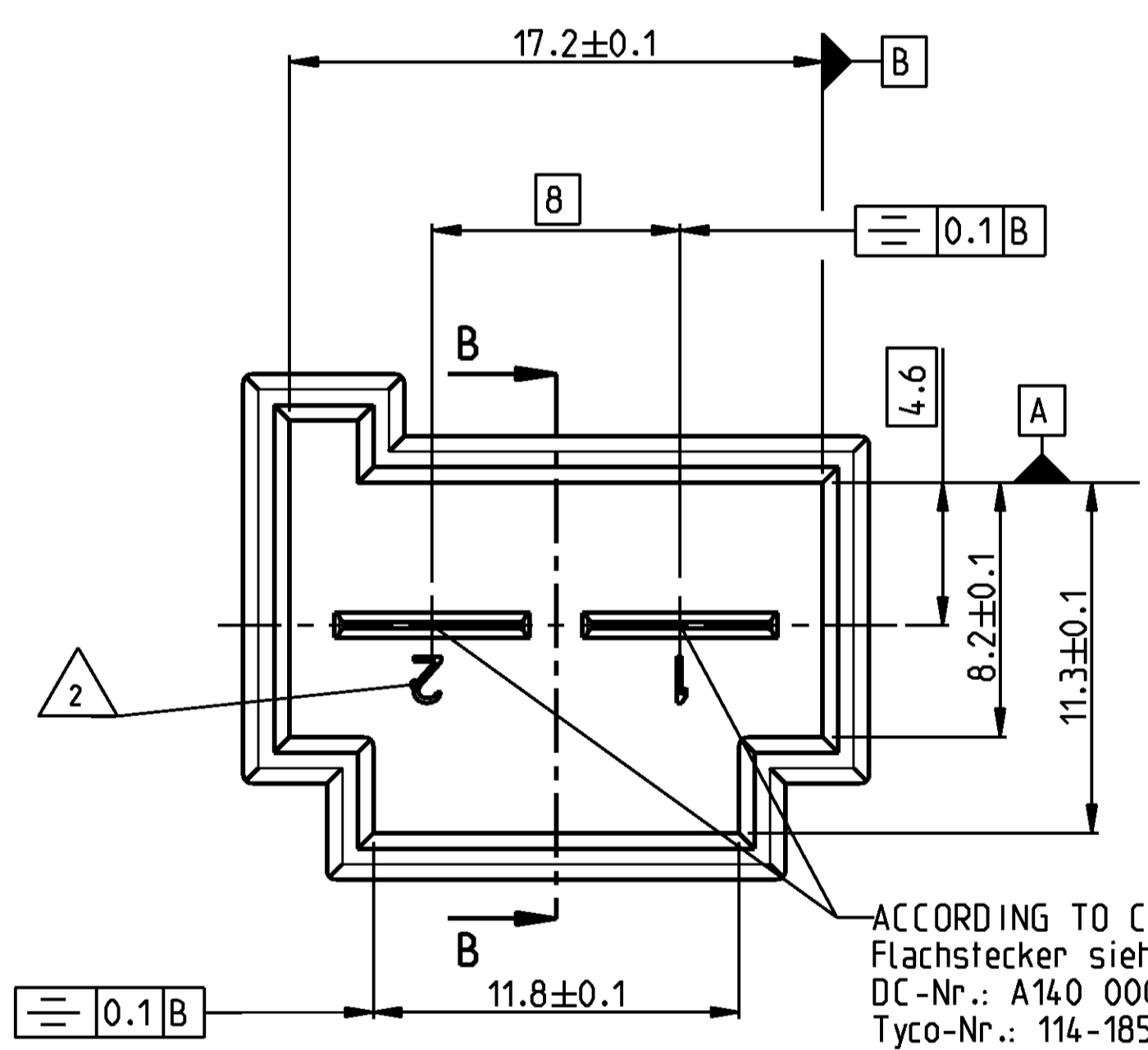
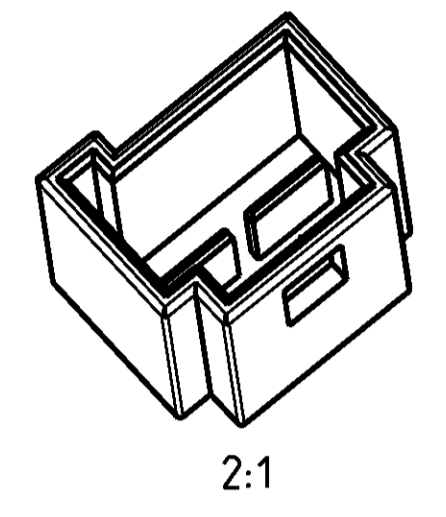
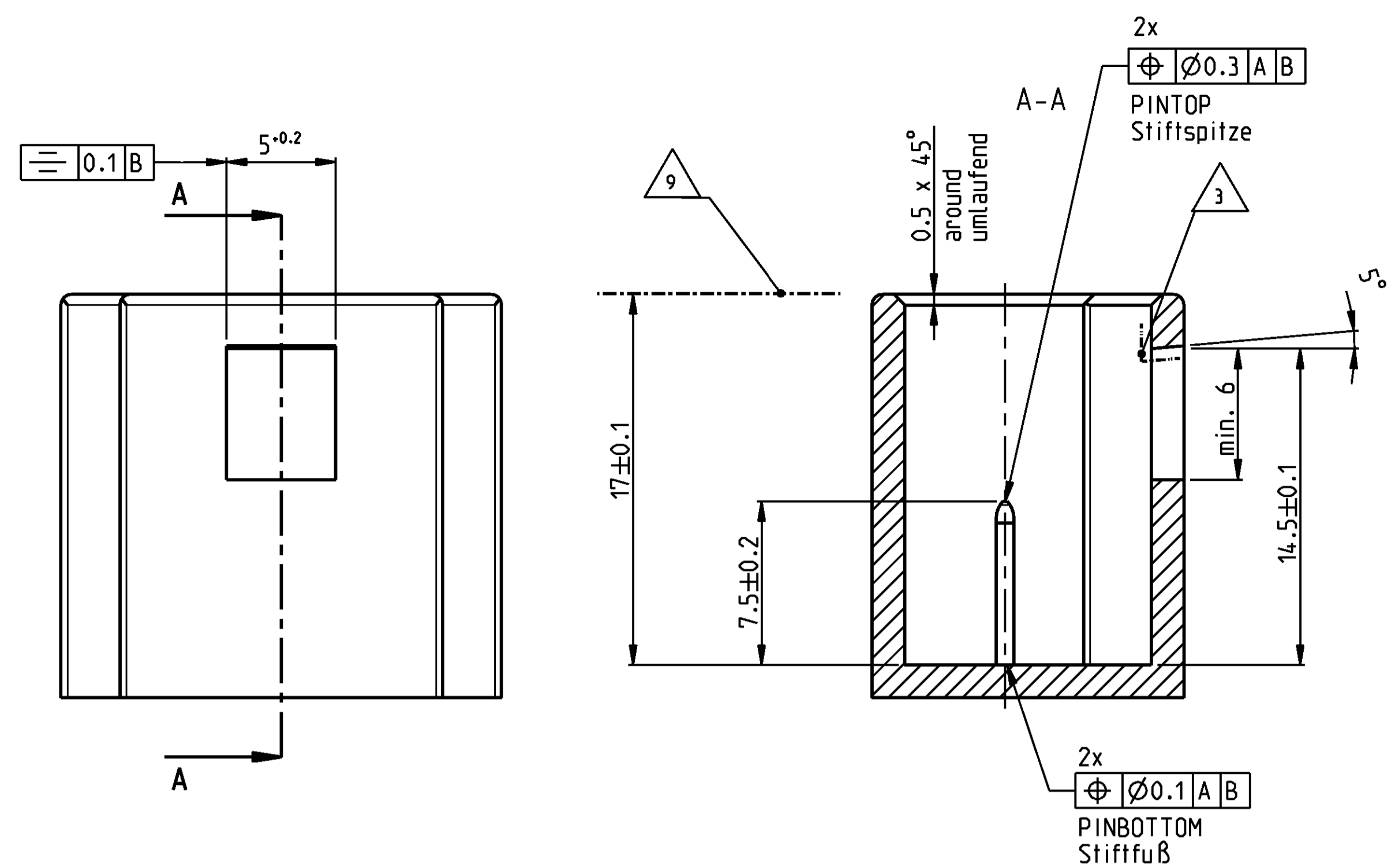
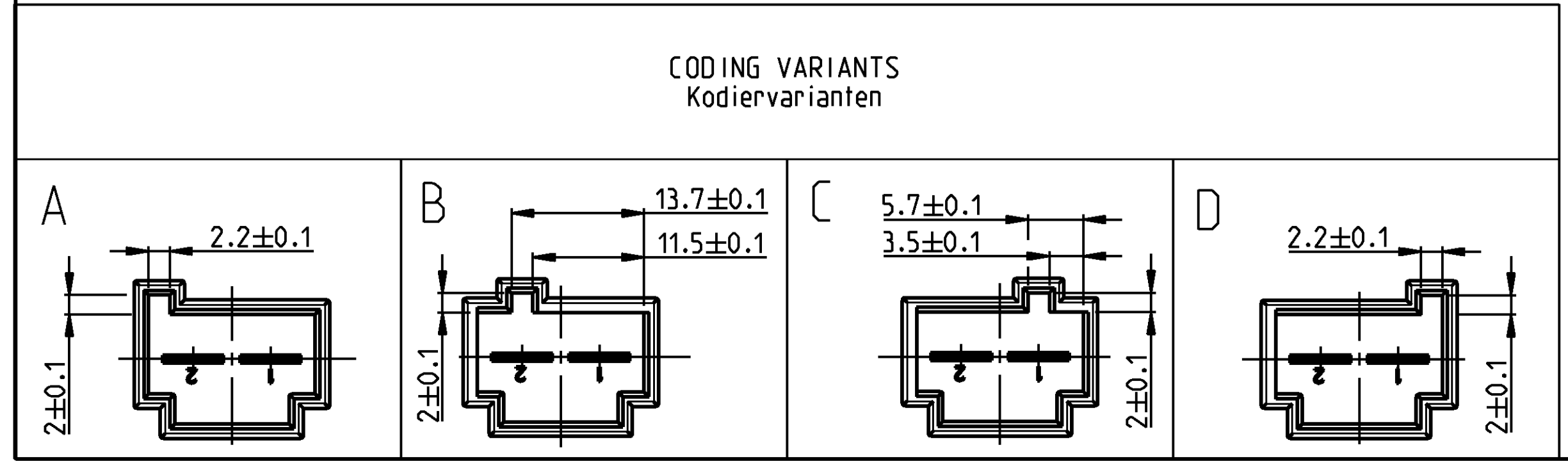

Lieferung nur nach Zeichnung und/oder CAD-Daten sowie erprobtem, freigegebenem Muster.  
Keinerlei Änderung ohne vorherige Freigabe durch die mit Änderungsvermerk der  
DaimlerChrysler AG versehene(n) Zeichnung/CAD-Daten.  
Delivery only in accordance with drawing and/or CAD data, and tested and approved  
sample. No change without advance approval by the drawing/CAD data identified with the  
modification note by DaimlerChrysler AG.

Prüfer/Checker	Datum/Date	Norm./Standard	Datum/Date	Abt./Dept.	Name	Datum/Date
DaimlerChrysler						

Benennung/Titel  
Ausführungsvorschrift (2fach)

DaimlerChrysler	Sach-Nr./Basic number	System	Formal	Blatt/Sheet
A	221 000 67 99			

NUR FÜR DAIMLERCHRYSLER

DATE	BY	APPV	NAME
12.JUN2002	H. Richardt		
18.JUL2002	H. Holland-Cunz		

TYCO ELECTRONICS	TYCO ELECTRONICS
AMP 4805 REV 31MAR2000	AMP 4805 REV 31MAR2000

PRODUCT SPEC	PRODUCT SPEC
2 POS CONNECTOR WITH TAB 6.3 X 0.8	2-pol. Anschluss, mit Flachstecker 6.3x0.8

SCALE	SCALE
1:1	1:1