

Application Specification

1. INTRODUCTION

This specification covers the requirements for application of the low-profile Ampulse Helicase solar junction box used as the primary electrical interface or junction for panel-based photovoltaic (PV) modules (solar panels) for off-grid connected power generation. The Solar Junction Box is attached at the back of the solar panel. The solar junction boxes collect the power generated by the solar cells and biases against reverse flow of current to prevent any damage to the panel. The junction box has an ingress protection rating of IP65 and is available in standard (non TÜV certified, PN 2286016-1, -3 & -4) and certified by TÜV Rheinland (PN 2286016-2) according to international standard DS/EN50548.

The solar junction box consists of a housing and a cover. The housing holds 3 rail contacts (ie., PN's 2286016-1, -2 & -4, Fig. 1A, 1C & 3 respectively, each with a solder cup) and 2 diodes (each with 2 legs that support it in place on the rail contacts). The PN 2286016-3 makes use of 1 diode and 2 Rails (Fig. 2) The staggered placement of the diodes provide optimum thermal management. The housing features 2 cable exit ports (each fitted with a single-lipped grommet) and a defined open attachment area used to electrically connect the solar junction box to the solar panel. The open attachment area allows the foil tabs of the solar panel to reach the interface tabs while maintaining a seal between the junction box and solar panel. The bottom of the housing has 4 standoffs used to ensure proper cohesion with the solar panel.

When corresponding with personnel, use the terminology provided in this specification to facilitate inquiries for information. Basic terms and features of this product are provided in Figure 1 (A), (B) & (C).

Figure 1 (A)

TE Part No: 2286016-1 (Non TÜV Certified)

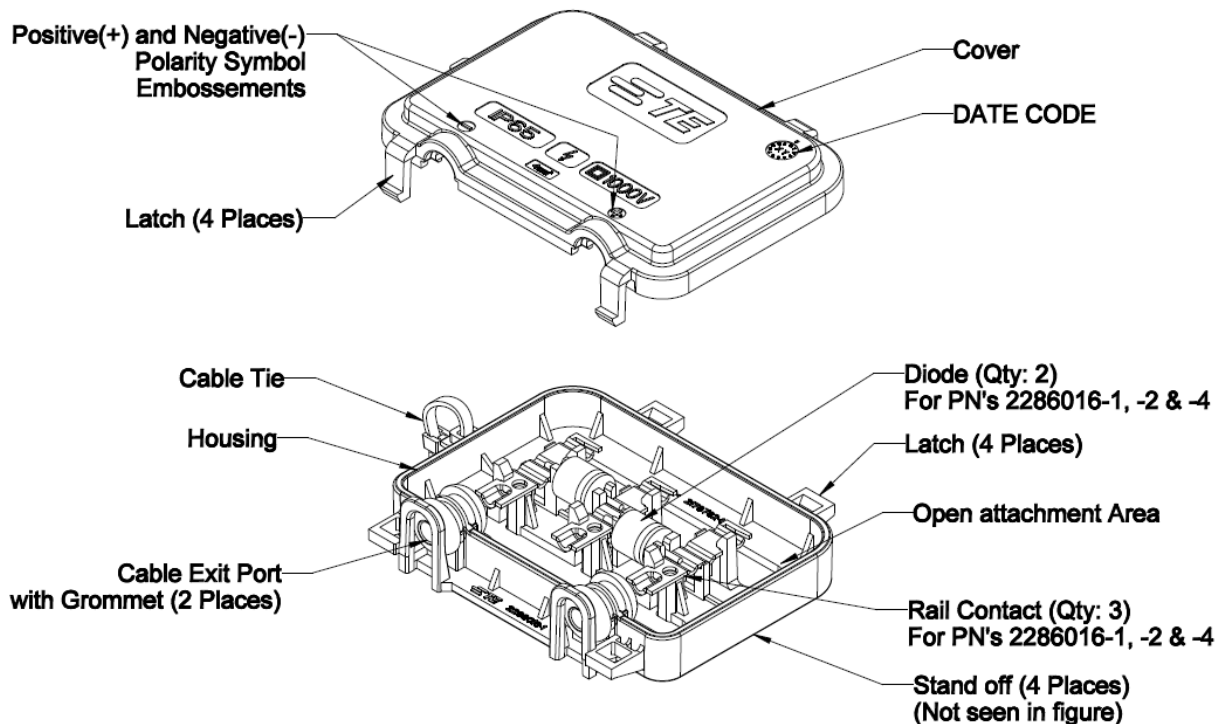

Figure 1 (B)

Bottom housing 2178782-1 of 2286016-1 (Non TÜV Certified) – Shown upside down

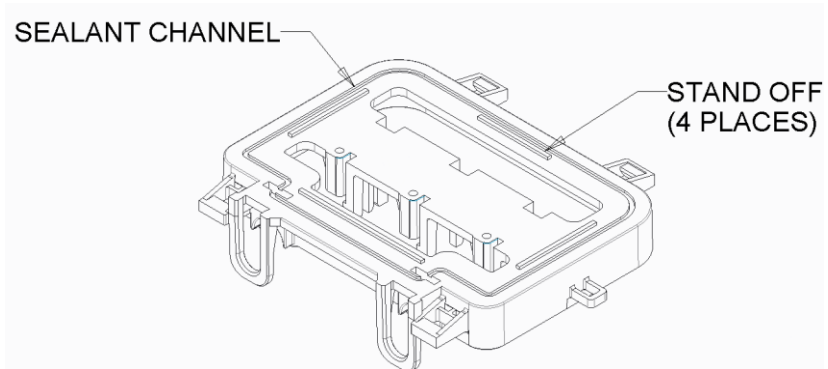
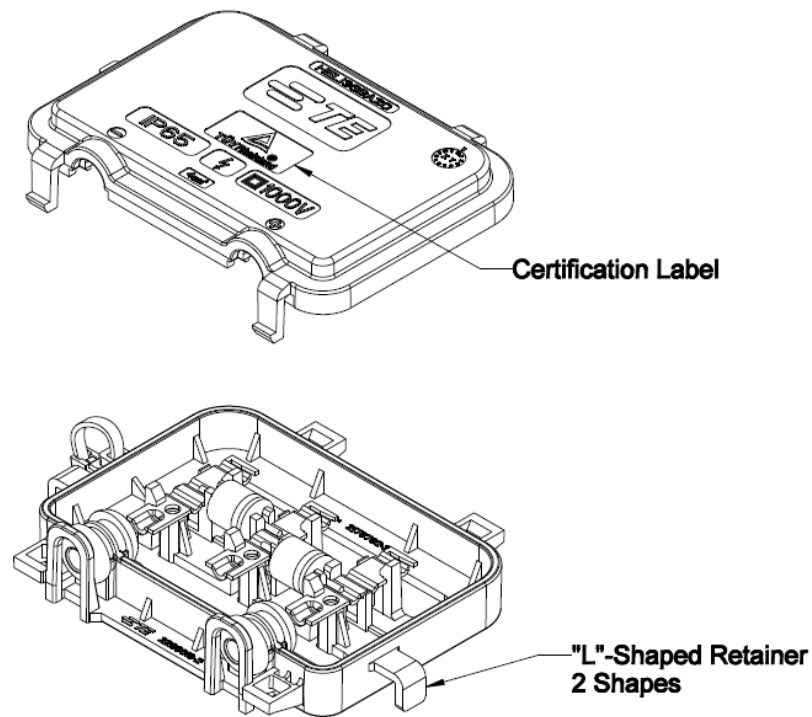

Figure 1 (C)

TE Part No: 2286016-2 (TÜV Rheinland Certified)



A cable tie, looped onto the side of the solar junction box, is used to prevent the cover from falling during installation. The certified solar junction box includes “L”-shaped cable retainer features to ensure robust cable retention.

The cover has an inner perimeter seal that, when the cover is closed, helps to prevent dust and water ingress.

The cover is closed by pressing the cover and housing together until the 4 latches engage. The cover is embossed with the IP65 rating, voltage, and positive and negative diode polarity symbols used to indicate proper cable connection. A date code is seen in-mold on the top surface of the Cover part.

Figure 2
TE Part No: 2286016-3 (Non TÜV)

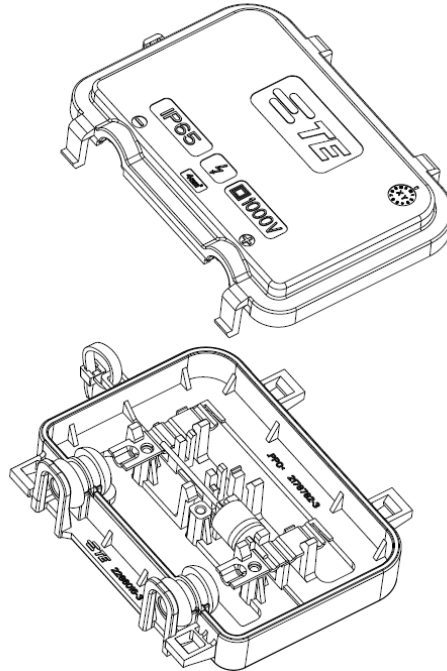

The housing holds 2 rail contacts (each with a solder cup) and 1 diode which contains long lead on +ve (Approx. 25.4mm nominal) polarity of Diode and short lead (Approx. 6 mm nominal) on -ve polarity of Diode. Each Diode leads are secured between the plastic slits which momentary hold the Diodes in place before soldering.

Figure 3
TE Part No: 2286016-4 (Non TÜV)

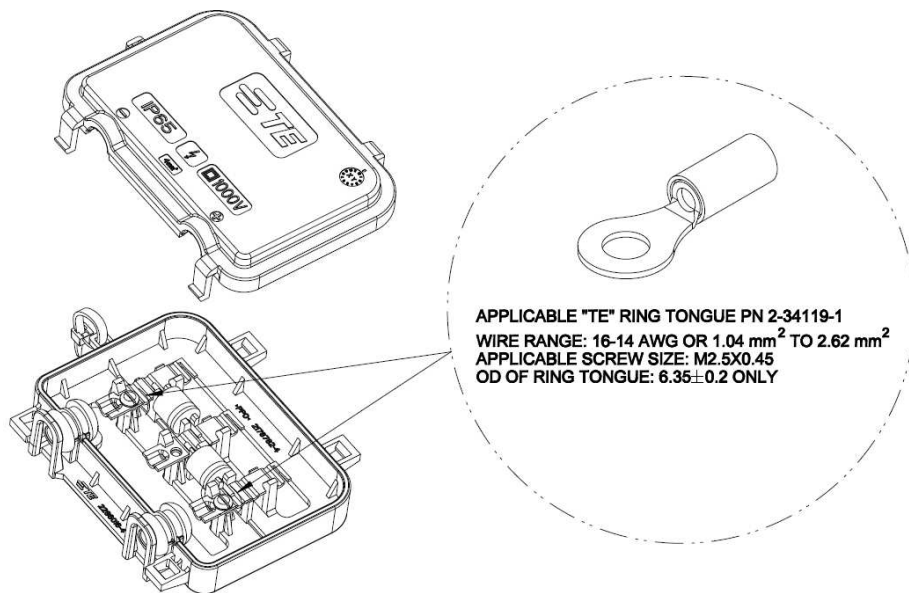

This Non-TÜV variant of JB allows Ring Tongue termination along with M2.5x0.45 screw combination. The recommended TE Ring Tongue PN has been provided for the user or otherwise equivalent Ring Tongue shall be considered. This variant shall be used if the wire size is 2.5 mm² only, thus meeting insulation diameter per Table 2.

Parameters of the solar junction boxes are:

Table 1

Parameter	Standard (Non-Certified)	TÜV Rheinland Certified
Current Rating	6 A	8 A
Grommet Color	Black	Blue

2. REFERENCE MATERIAL

2.1. Revision Summary

Revision	Date	Description of change	Checked	Approved
A	15OCT2015	Initial release	Rakshith Nayak R	Praneeth P Shetty
A1	24MAR2017	Date code updated, Addition of new variants ie., 2286016-3 & -4	Gururaj S	Nimbennappa G

2.2. Customer Assistance

Reference Product Base Part Number 2286016 and Product Code E46 are representative of the low-profile Ampulse Helicase solar junction box. Use of these numbers will identify the product line and help you to obtain product and tooling information. Such information can be obtained through a local Representative, by visiting our website at www.te.com, or by calling Product Information or the Tooling Assistance Center at the numbers at the bottom of page 1.

2.3. Drawings

Customer Drawings for product part numbers are available from the service network.

If there is a conflict between the information contained in the Customer Drawing 2286016 and this specification or with any other technical documentation supplied, call the Product Information Center

2.4. Specifications

Product Specification 108-32067 provides product performance and testing procedure with testing sequence.

2.5. Standards and Publications

DS/EN 50548, "Junction Boxes for Photovoltaic Modules"

IEC 60529, "Degrees of Protection Provided By Enclosures (IP Code)"

3. REQUIREMENTS

3.1. Safety

Do not stack product shipping containers so high that the containers buckle or deform.

3.2. Material

The cover and housing are made of ultra-violet (UV) resistant material, the grommets and seal are made of silicone, and the rail contacts are made of copper alloy.

3.3. Storage

A. Shelf Life

The product should remain in the shipping containers until ready for use to prevent deformation to components. The product should be used on a first in, first out basis to avoid storage contamination that could adversely affect performance.

B. Chemical Exposure

Do not store product near any chemical listed below as they may cause stress corrosion cracking in the material.

Alkalies	Ammonia	Citrates	Phosphates	Citrates	Sulfur Compounds
Amines	Carbonates	Nitrites	Sulfur	Nitrites	Tartrates

3.4. Limitations

The solar junction box is designed to operate in a temperature range of -40 to 85°C. Maximum operating voltage is 1000 VDC.

3.5. Cable Selection and Preparation

The solar junction box accepts cable conductor size range of 2.5 to 4 mm² with an insulation diameter as given in Table 2.

The cable must be stripped to the dimension given in Figure 4.

Figure 4

Note: Not to Scale



Table 2

SOLAR JUNCTION BOX	WIRE INSULATION DIAMETER RANGE
Standard (Non-Certified)	Min 4.5 mm- Max 5.5 mm
TÜV Rheinland Certified	

3.6. Installation



DANGER

To avoid personal injury, the circuit load must be disconnected before connecting cable. Cable must not be connected under electrical load.

The following requirements must be met when installing the solar junction box.

1. The environment area for installation is clean and dry.



CAUTION

Exposing the internal components of the solar junction box to any type of contaminants (such as moisture, dust, humidity, environmental pollution, etc.) can negatively affect function of the solar junction box over the duration of use. The internal components must be protected.

2. Adhesive sealant applied to the housing is securing the solar junction box to the back of the solar panel. Dow Corning PV-804 neutral high-performance silicone adhesive sealant or equivalent is recommended.

NOTE

It is recommended that the cover of the solar junction box be removed before applying the adhesive sealant.
 — The adhesive sealant fills (and it is not necessary to go beyond) the open attachment area of the housing.



CAUTION

It is important that the adhesive sealant is not anywhere on or near the perimeter of the housing or latches that prevents a tight closure or removal of the cover.

— The diodes, diode legs, and rail contacts should not be mishandled or pressed when securing the solar junction box to the solar panel.



CAUTION

Mishandling or pressing the diodes, diode legs, or contact rails can cause mechanical stress on the components and result in malfunction of the solar junction box and hence the solar panel.

3.7. Connection

The following requirements must be met when connecting the solar junction box.

NOTE

The adhesive sealant that secures the solar junction box to the solar panel must be fully cured before connecting cable or testing.

Following are the steps to attach the AMPULSE HELICASE solar junction box to the solar panel.

1. Open the box with the help of a flat screw driver, by disengaging all 4 latches. Take care not to apply too much force on the latch, so to avoid any damage to the latches. A 3 mm standard flat bladed screwdriver must be used to open the cover of the solar junction box. Figure 5 (A) and (B) shows the appropriate method to open the junction box

Figure 5 (A)

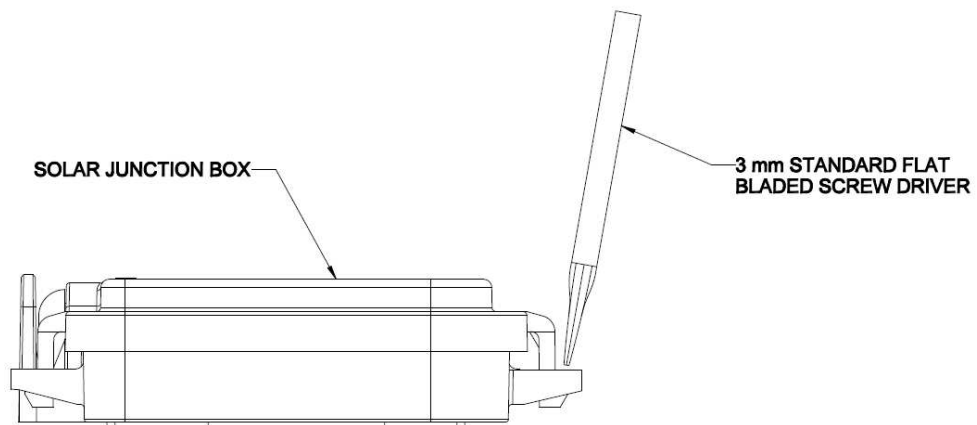
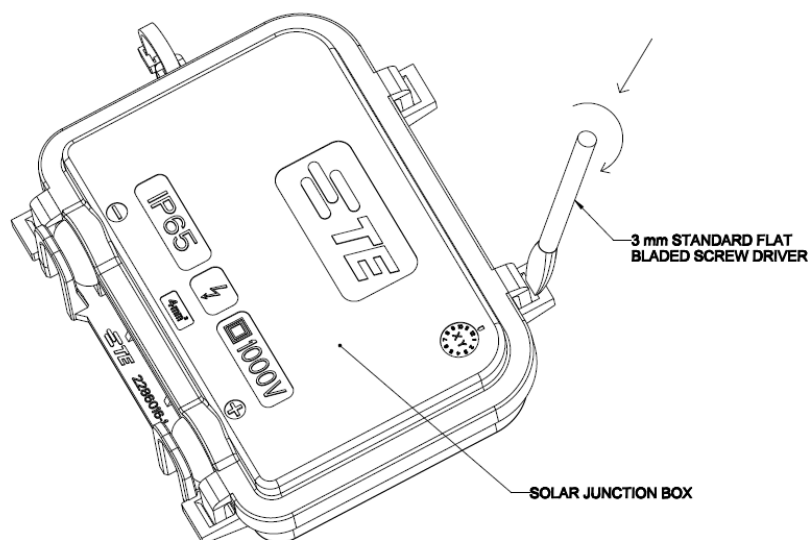

Figure 5 (B)



2. The foils from the solar panel are pulled through the open attachment area and soldered on to the contact rails
3. Apply adhesive on the back of the junction box along the sealant channel in an amount such that the bead would exceed the height of standoff but not such that it would spread and interfere with latch engagement after the junction box is pressed onto the back of the panel.

NOTE

For the TÜV certified junction box, care shall be taken while applying the adhesive, such that the adhesive shall not interfere with wire routing through the “L” feature. Take care to ensure minimum stress on the grommets so as not to compromise its IP rating.

4. Allow the adhesive/sealant to cure as guided by the manufacturer of the adhesive.

After the adhesive is cured, now the product is ready to be connected to the system.

5. Strip the cable per Figure 4.
6. Route the cable through the arch, then through the grommet by carefully considering the polarity ('+' and '-') embossed on the top cover of the junction box.
 - Cables are not bent, stretched, crushed, or confined in any way. A minimum bend radius of greater than 5 times the diameter of the largest cable is maintained.
 - The cables are routed so that tensile stress on the connection is prevented
7. Ensure the grommet is properly seated on the “U” shaped platform of the bottom housing.

**CAUTION**

To avoid risk of dust and water ingress, the grommets and seal must not be damaged in any way.

8. Solder the wire to the contact rail.
Each cable is soldered to a rail contact. The solder cup of the rail contact is full. The cables match the polarity markings embossed on the cover.

The junction box also provides an option to terminate wire using terminals (Ring Tongue) crimped to the wire after routing through grommet. The termination can be done by fastening using a M2.5x0.45 screw to the tapped Contact Rails and through the Hole feature provided in the bottom housing of the junction box. Please refer to Figure. 3.

9. The junction box is designed to have its top cover and the bottom housing to be self-aligning.
 - Firstly, Secure the latches on the No-Grommet side (2 audible clicks and tactile feedback)
 - Then, Secure the latches on the Grommet side of junction box (2 audible clicks and tactile feedback)

Ensure the cover is evenly seated around the perimeter of the housing, and the four latches are fully seated.

**CAUTION**

To avoid risk of water and dust ingress, the inner perimeter seal must be seated in the groove of the housing, must not be damaged in any way, and must not be visible after the cover is closed.

Figure 6

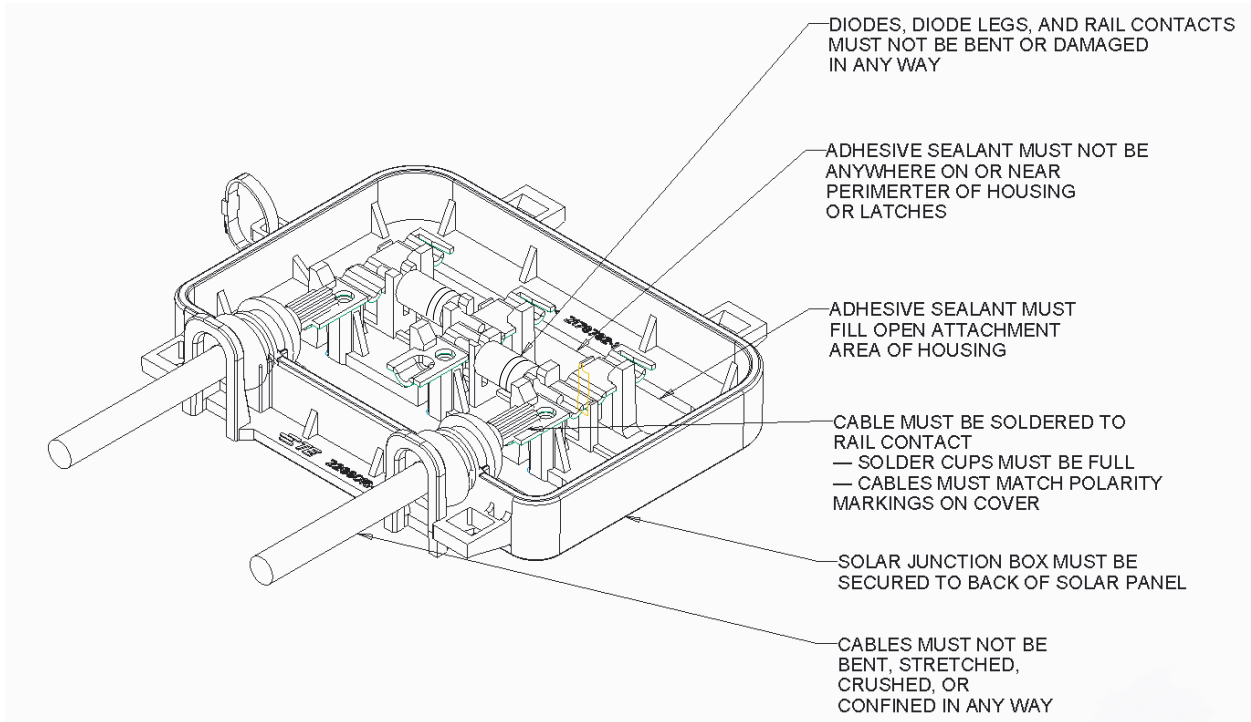

3.9. Removal and Repair



DANGER

To avoid personal injury or death, the cover of the solar junction box must **never** be opened while it is under electrical load. Components inside the solar junction box may be electrically charged and capable of causing severe injury or death. **Extreme caution** must be taken when opening the cover of the solar junction box.

The solar junction box and components of the junction box are not repairable. Removing the solar junction box from the solar panel will cause damage to the junction box and solar panel. Damaged or defective product must not be used.

If a diode becomes separated from the contact rails, the solar junction box must be replaced.

There is no defined cleaning process. During service condition care shall be taken that junction box is opened in clean atmosphere. (Dust & Moisture free)

4. QUALIFICATION

Agency evaluation for low-profile Ampulse Helicase solar junction box has been successfully completed and the certificate is being awaited at the time of publication of this application specification.

5. TOOLING

No special tooling is required for installation or connection. A 3 mm standard flat bladed screwdriver must be used to open the cover of the solar junction box.

6. VISUAL AID

The illustration below shows a typical application of the low-profile Ampulse Helicase solar junction box - TE Part No: 2286016-2 (TÜV Rheinland Certified). Please note that the adhesive is not shown in the figure. This illustration should be used by production personnel and in the field to ensure a correctly applied product. Applications which do not appear correct should be inspected using the information in the preceding pages of this specification.

Figure 7

