

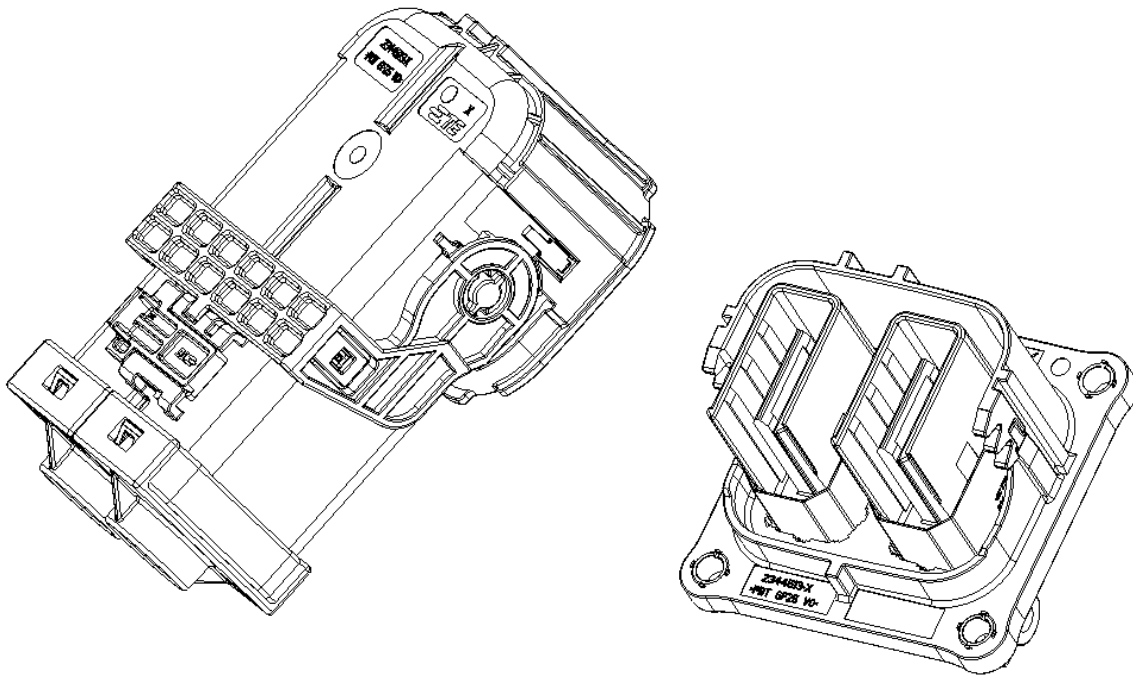

PCON21 2POS 90DEG Application Specification

PCON21 两位 90 度高压大电流连接器 应用规范



A5	Add New Cable	A.L	15NOV2023	PR: D.DI DATE:20JUN2019	 TE Connectivity Shanghai, China	Document No.: 114-32326	LOC: ES	REV: A4
A4	Add Terminal PN	A.L	30OCT2023					
A3	Updated part No.	A.L	02DEC2022	CHK: E.JIANG DATE:31AUG2019				
A2	Updated cable	W.Z	10MAY2022					
A1	Updated Spec	W.Z	21JAN2022	APP: I.YIN DATE:31AUG2019				
LTR	REVISION RECORD	PR	DATE					



CONTENT 目录

1. SCOPE 适用范围	3
1.1 Content 内容	3
1.2 Processing notes 加工说明	3
2. APPLICABLE DOCUMENTS 适用文件	3
2.1 TE Connectivity Documents 泰科电子文件	3
2.1.1 Customer drawings 客户图纸	4
2.1.2 Specifications 规范	6
2.2 General Documentation 通用文档	6
2.2.1 Cable Specification 线缆规格	6
3. CONDITION OF DELIVERY AND PACKAGING 交货和包装状态	7
3.1 Components 零部件	7
3.2 Packaging and Storage 包装和贮存	8
4. APPLICATION TOOLS 应用工装	9
4.1 PCON21 contact 90deg / PCON21 90 度端子	9
4.2 Shielding 屏蔽	9
5. ASSEMBLY INSTRUCTIONS 组装说明	10
5.1 Overview of all parts should be assembled 全部部件总览图	10
5.2 Shielded cable, contact, and inner housing assy 屏蔽线、端子、内壳体	11
5.2.1 Contact crimp 端子压接	13
5.2.2 Insert crimped contact into Inner Housing 端子与内部塑件的组装	13
5.2.3 Shielding crimp 屏蔽压接 (shielding version)	15
5.3 Plug Housing 母端壳体	17
5.3.1 Insert cable assembly into the Plug Housing 线缆组件装入母端壳体	17
5.3.2 Assemble cable seal assembly 组装线材密封组件	18
5.3.3 Press TPA to end-lock position TPA 压到终锁位	18
6. FINAL EXAMINATION 终检	18
6.1 Visual Examination 外观检查	18
6.2 Electrical Tests 电气测试	18
7. HEADER ASSY AND PLUG ASSY INSTRUCTIONS 公母端安装说明	19
7.1 Header assembly 公端安装	19
7.2 Plug assembly 母端安装	20
8. APPENDIX 附录	23
8.1 Data sheets 数据表	23
8.1.1 XinHongYe shield cable 70 to 90mm ² 鑫宏业 70 到 95 平方屏蔽线	23
8.1.2 Force shield cable 50 to 95mm ² 福斯 50 到 95 平方屏蔽线	23
8.1.3 KBE shield cable 95mm ² KBE50 到 95 平方屏蔽线	23
8.1.4 Force un-shield cable 70mm ² Force70 到 95 平方非屏蔽线	23



- ◆ This connector is intended for use in high-voltage applications. Special care must be applied to ensure that the connector functions as intended.
- ◆ If you suspect that the connector has been modified, damaged, contaminated or other wise compromised, please discontinue it use immediately.
- ◆ This connector should only be serviced by a trained and qualified technician.

1. SCOPE 适用范围

1.1 Content 内容

This specification covers the requirements for application of the sealed PCON21 2POS 90DEG High Voltage connector. The PCON21 connector system is designed to meet LV215-1 specifications and for a metric wire size range of 50mm² up to 95mm² (acc. to LV216-2). The connector incorporates conductive EMI shields to reduce radiated emissions in the application.

The PCON21 connector is available for 4 different keying or polarizing configurations with a lever for low mating / unmating forces. The connector system incorporates the 21mm power contacts and an integrated High Voltage Interlock (HVIL) System. The housings are molded in orange to denote a high voltage system.

该规范涵盖了密封PCON21 2POS 90DEG高压连接器的应用要求。PCON21连接器系统的设计符合LV215-1规范，公制线径范围为50mm²至95mm²（符合LV216-2标准）。该连接器采用导电EMI屏蔽，以减少应用中的辐射。PCON21连接器有4种不同的键位，采用杠杆齿轮结构来降低配合力。连接器系统包含21毫米电源链接和集成的高压互锁（HVIL）系统和高压手指防护(IPXXB, UL)要求。外壳采用橙色模制，表示高压系统。

1.2 Processing notes 加工说明

The processor is responsible for ensuring the quality of the manufacturing process and the proper function of the system. The warranty and liability is excluded, if quality deficiency or damages occurs by failing compliance to this specification or using not specified, not released tools or not released connector components.

加工者负责确保制造过程的质量和系统的正常功能。如果由于未遵守本规范或使用未定义的、未发布的工装或未发布的连接器组件而导致质量异常或损坏，则不承担保修和责任。

2. APPLICABLE DOCUMENTS 适用文件

The following mentioned documents are part of this specification. If there is a conflict between the information contained in the documents and this specification or with any other technical documentation supplied, the last valid customer drawings takes preference.

以下提到的文件是本说明书的一部分。如果文档中包含的信息与本规范或提供的任何其他技术文档之间存在冲突，则最新有效的客户图纸优先。

2.1 TE Connectivity Documents 泰科电子文件

This Application Specification based on the latest valid customer drawings.

本应用规范基于最新的有效客户图纸。



2.1.1 Customer drawings 客户图纸

Table 1: Customer drawings 客户图纸

Shielding Header side (Include interface) / 屏蔽公端(包括应用面板)	
2344512	2POS,21MM,HEADER HSG,ASSY
2357574	
2384721	
2393017	
2391644	

Unshielding Header side (Include interface) / 非屏蔽公端(包括应用面板)	
2396301	2POS,21MM,HEADER HSG,ASSY

Shielding Plug side / 屏蔽母端	
2344520	2POS,21MM,PLUG HSG,90 DEG,ASSY,SEALED
2344525	2POS,21MM,UPPER HSG,90 DEG,ASSY
2344529	2POS,21MM,LOWER HSG,90 DEG,ASSY
2317017	90DEG PCON21 CONTACT
OR 2425991	90DEG PCON21 CONTACT(Localization of China)
2344532	GASKET RING
2344533	SHIELD CRIMP FERRULE
2367292	2POS,21MM,PLUG HSG,90 DEG,ASSY,SEALED



2367295	2POS,21MM,CABLE SEAL COVER
---------	----------------------------

Unshielding Plug side / 非屏蔽母端	
2396300	2POS,21MM,PLUG HSG,90 DEG,ASSY,SEALED, UNSHIELDING
2344527	2POS,21MM,UPPER HSG,90 DEG
2396428	2POS,21MM,LOWER HSG,90 DEG
2317017	90DEG PCON21 CONTACT
OR 2425991	90DEG PCON21 CONTACT(Localization of China)
2367292	2POS,21MM,PLUG HSG,90 DEG,ASSY,SEALED
2367295	2POS,21MM,CABLE SEAL COVER

Application tools / 应用工装	
2326139-1	PCON21 contact 90deg crimp tool(for 70mm ² to 95mm ² cable)
2305470-1	HV die holder for HV20 or HF20
2358771-1	Shield crimp tool for 70mm ² cable
2371490-1	Shield crimp tool for 95mm ² cable
2383675-1	Shield crimp tool for 70mm ² cable (COFICAB)
2374313-1	Shield crimp tool for 95mm ² cable (COFICAB)
2151491	MQS contact crimp tool



x-878591-x	
3-1579001-5 5-1579001-72	MQS Hand crimp tool
2326138-1	PCON21 contact 90deg crimp tool(for 25mm ² to 50mm ²)

2.1.2 Specifications 规范

Table 2: TE-specifications / 泰科规范

Specifications	Description
108-94638	Product Specification PCON21 Contact 90DEG
108-18030	Product Specification MQS Contact system
108-32326	Product Specification PCON21 2Pos 90DEG
114-32326	Application Specification PCON21 2Pos 90DEG
114-94511	Application Specification PCON21 Contact 90DED
114-18021	Application Specification MQS Contact system

2.2 General Documentation 通用文档

2.2.1 Cable Specification 线缆规格

The connector is designed to meet LV216-2 specification for metric wire range 50 up to 95mm². Cable Specification acc. To the appendix.

连接器设计符合LV216-2规范，适用于公制线缆范围50至95mm²，线缆规格见附录。



3. CONDITION OF DELIVERY AND PACKAGING 交货和包装状态

3.1 Components 零部件

Table 3 shows the required components for assembly of PCON21 2POS 90DEG Plug

Description 描述	Usage 用量	PN for 70mm ² 70 平方线部件号	PN for 95mm ² 95 平方线部件号	PN for 50mm ² 50 平方线部件号	PN for 95mm ² (COF) 95 平方线部件号
Plug housing assy	1	*-2344520-*			
		(Definite PN see customer drawing)			
90DEG contact	2	2317017-2 OR 2425991-1		2317017-1	2317017-2 OR 2425991-1
Upper housing assy	2	2344525-1	2-2344525-1	5-2344525-1	3-2344525-1
Lower housing assy	2	2344529-1	2-2344529-1	5-2344529-1	3-2344529-1
Gasket ring	2	2344532-1			
Shield crimp ferrule	2	2344533-1	2-2344533-1	5-2344533-1	3-2344533-1
Cable seal assy	2	2367292-1	2-2367292-1	5-2367292-1	3-2367292-1
Cable seal cover	2	2367295-1	2-2367295-1	5-2367295-1	3-2367295-1



Description 描述	Usage 用量	PN for unshielding 70mm ² 70 平方非屏蔽线部件号
Plug housing assy	1	*-2396300- (Definite PN see customer drawing)
90DEG contact	2	2317017-2 OR 2425991-1
Upper housng	2	6-2344527-1
Lower housing	2	2396428-1
Cable seal assy	2	6-2367292-1
Cable seal cover	2	6-2367295-1

3.2 Packaging and Storage 包装和贮存

The products should be used on a “first in, first out” basis to avoid storage contamination, see latest valid customer drawings too.

为避免存储污染，产品应以“先进先出”的原则使用，也请参见最新的有效客户图纸。

4. APPLICATION TOOLS 应用工装

The Application tools are only valid for the specified cables at appendix. More tooling information can be obtained through a local TE Representative, or after purchase, by calling the product information Center.

应用工装仅对附录中的指定电缆有效。可通过当地TE代表获取更多工装信息，或者在购买后，拨打产品信息中心电话。

4.1 PCON21 contact 90deg / PCON21 90度端子

Table 4. Required application tools contact crimp

Application tools / 应用工装	
2326139-1	PCON21 contact 90deg crimp tool(for 70mm ² to 95mm ² cable)
2305470-1	HV die holder for HV20 or HF20
2326138-1	PCON21 contact 90deg crimp tool(for 25mm ² to 50mm ²)



Figure1: PCON21 contact 90deg crimping applicator

4.2 Shielding 屏蔽

The following table contains the required order numbers for application tools.

下表包含所需应用工装的订货号。

Table 5: Application tools

Application tools / 应用工装	
2305470-1	HV die holder for HV20 or HF20
2374313-1	Shield crimp tool for 95 mm ² (Coficab cable)
2371490-1	Shield crimp tool for 95 mm ² (LV216 cable)
2383675-1	Shield crimp tool for 70 mm ² (Coficab cable)

2358771-1	Shield crimp tool for 70 mm ² (LV216 cable)
2385669-1	Shield crimp tool for 50 mm ²

5. ASSEMBLY INSTRUCTIONS 组装说明

The following procedures show the details of the cable assembly and insertion instructions of the cable assembly into the plug housing subassembly. The processing is only valid for the specified cable at appendix and only these combinations have been validated by TE. Alternative cables may be used after ensuring performance through validation testing.

下述步骤显示了线缆组件的细节和线缆组件插入母端壳体子组件的插入说明。该制程仅对附录中的指定线缆有效，并且仅这样的组合通过TE验证。在通过验证测试性能之后，可以使用替代电缆。

5.1 Overview of all parts should be assembled 全部部件总览图

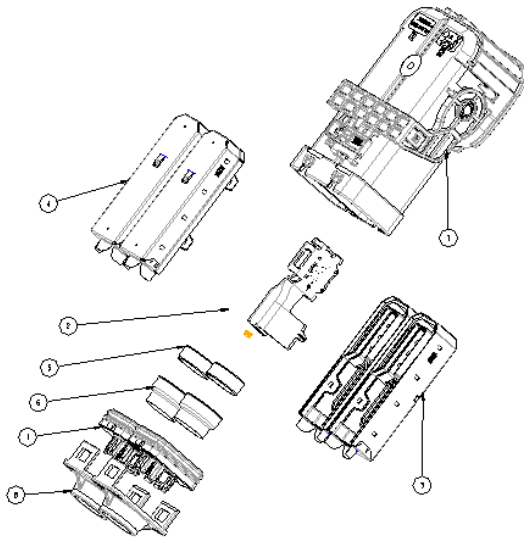
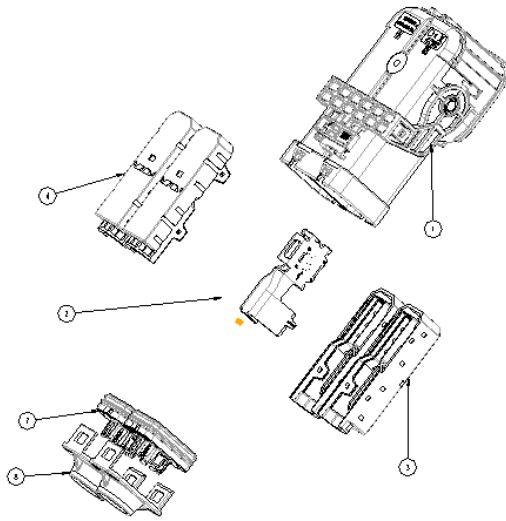

Figure2: PCON21 contact 90deg overview(shielding)

Table 6: Components cable assembly

2	2POS, 21MM, CABLE SEAL COVER	8
2	2POS, 21MM, CABLE SEAL CLIP, ASSY	7
2	SHIELD CRIMP FERRULE	6
2	GASKET RING	5
2	2POS, 21MM, LOWER HSG, 90 DEG, ASSY	4
2	2POS, 21MM, UPPER HSG, 90 DEG, ASSY	3
2	90DEG TERMINAL ASSY	2
1	2POS, 21MM, PLUG HSG, 90 DEG, ASSY, SEALED	1
QTY	DESCRIPTION	ITEM



2	2POS, 21MM, CABLE SEAL COVER	6
2	2POS, 21MM, CABLE SEAL CLIP, ASSY	5
2	2POS, 21MM, LOWER HSG, 90 DEG, ASSY	4
2	2POS, 21MM, UPPER HSG, 90 DEG, ASSY	3
2	90DEG TERMINAL ASSY	2
1	2POS, 21MM, PLUG HSG, 90 DEG, ASSY, SEALED	1
QTY	DESCRIPTION	ITEM

Figure2: PCON21 contact 90deg overview(unshielding)

5.2 Shielded cable, contact, and inner housing assy 屏蔽线、端子、内壳体

Safety information, avoid prolonged or repeated skin with conductor or shieldings (wear protective gloves). Please note, the procedure of assembly the shielded cable is provided in two documents, the following steps shows the assembly without contact processing.

安全提醒，避免皮肤长时间或重复与导体或屏蔽接触（戴防护手套）。
请注意，屏蔽线缆的组装步骤在两个文档中提供，以下组装步骤不包含端子。

In order shown in figure 3, slide Cable seal assy and Shield crimp ferrule (屏蔽版本) onto cable sheath, so that they are not in crimp work area.

按照图3所示的顺序，滑动密封组件和屏蔽压接(屏蔽版本)套管到电缆护套上，使它们不在压接区域。

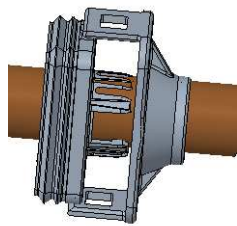

Unshielding Version

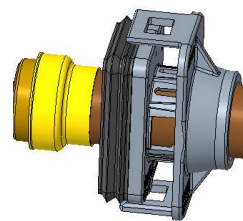

Shielding Version

Figure 3: Before processing slide components onto cable

Strip and remove outer sheath, screening braid (if present screening foil), inner sheath and conductor from the end as shown in figure 4.

如图4所示，从末端切开并去除外护套，屏蔽编织物（如果存在屏蔽箔），内护套和导体。

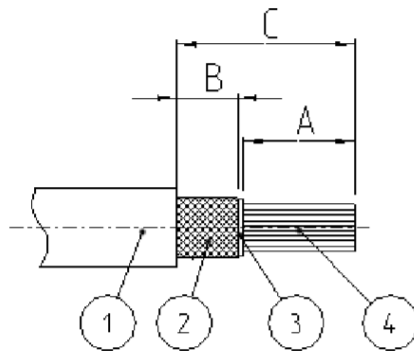

Figure 4: Cutting cable to length

Stripping dimensions for exposing cable.



Attention: Cable sheath and shielding braid shall not be cut or broken during the cutting procedure.
注意：切割过程中不得切割或破坏电缆护套和屏蔽编织层。

Table 7: Cutting dimensions 剥线尺

Shielding Version

(ID)	Cable Design	A [mm]	B [mm]	C [mm]
1	Outer sheath	--	--	38.5±0.5
2	Screening braid	--	(15)	--
3	Inner sheath	--	(20.5)	--
4	Conductor	18±0.5	--	--

Unshielding Version

(ID)	Cable Design	A [mm]
1	Outer sheath	--
4	Conductor	18±0.5

Comb out screening braid and assemble gasket ring.



Attention: Shielding braid shall not be broken.
注意：屏蔽编织不得被破坏

Comb out and turn over screening braid to the cable sheath, and slide gasket ring in front of braid (do not cover braid)
梳理并翻折到屏蔽编织到线材外护套上(以便翻回到屏蔽壳上), 并把衬环套到编织的前部(不用压住编织)。

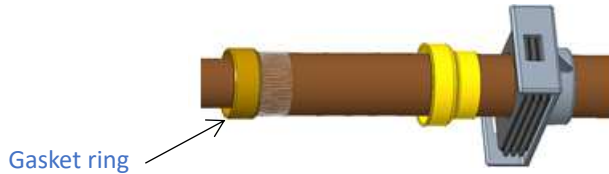

Figure 5: Comb out screening braid and assemble gasket ring

5.2.1 Contact crimp 端子压接

See latest TE-Application specification 114-94511. The cable should be as defined in the SPEC or connector.
详见最新的泰科应用规范114-94511. 电缆应是SPEC或连接器中定义的。

Please note, in this processing, gasket ring must keep away with contact and close to braid. (shielding version)
请注意, 压接过程中, 衬环必需远离端子靠近编织. (屏蔽版本)

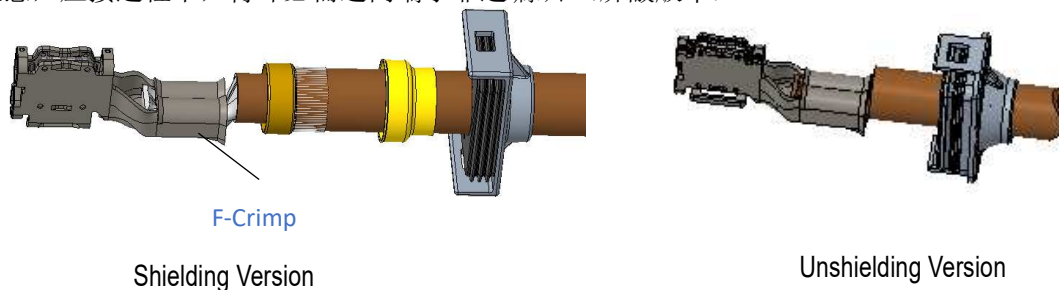

Figure 6: Contact crimp

5.2.2 Insert crimped contact into Inner Housing 端子与内部塑件的组装

Please note, in this processing, gasket ring must keep away with contact and close to braid (shielding version)
请注意, 此过程中, 衬环必需远离端子靠近编织. (屏蔽版本)

Insert contact into upper housing assy until it stops against upper housing.
压接后端子插入上盖组件直到止位。

Gasket ring slide to inside-contact area of upper shield as shown in figure 7.
如图7所示,衬环滑动到上屏蔽的内接触区.

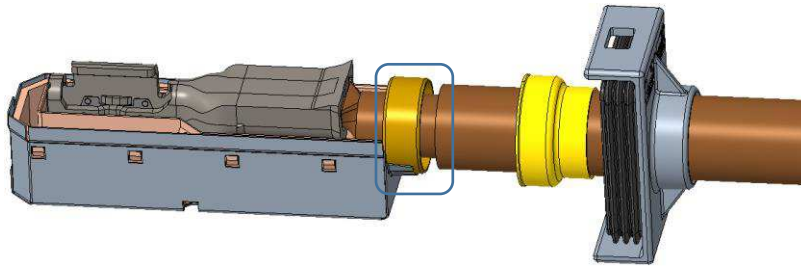

Shielding Version

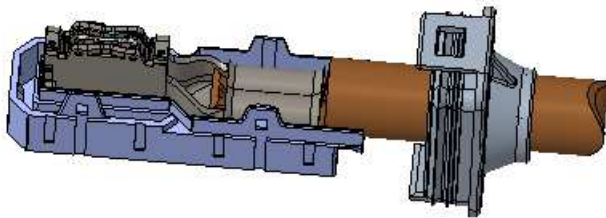

Unshielding Version

Figure 7: Insert contact and prepare gasket ring

Assemble lower housing assy until it makes “click”, and inside-contact area of upper shield touch with gasket ring as figure 8 shown.

如图8所示, 组装下盖组件知道发出“咔嚓”声, 且下屏蔽的内接触区与衬环接触

Please note, upper shield and lower shield contact area mating overlap as figure 9 shown.

请注意, 如图9所示上屏蔽与下屏蔽接触区的重叠区

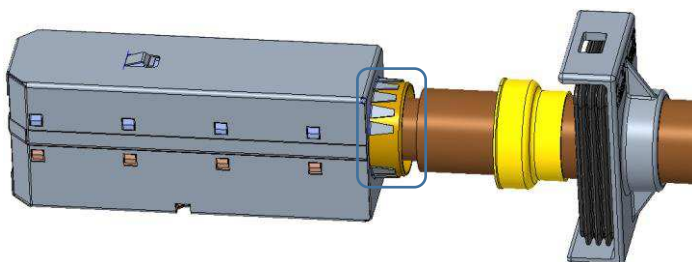

Shielding Version

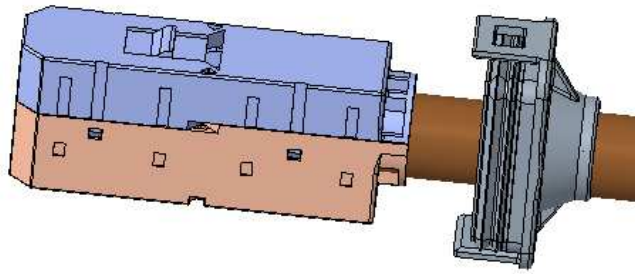

Unshielding Version

Figure 8: Insert contact and prepare gasket ring

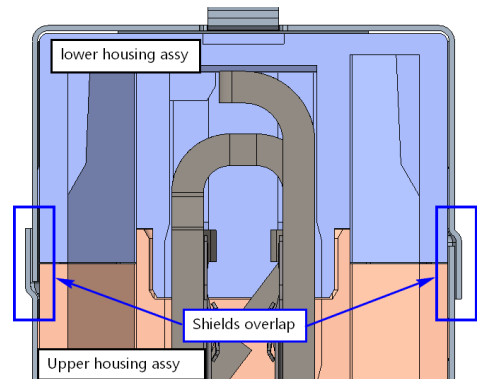

Figure 9: Shields overlap

5.2.3 Shielding crimp 屏蔽压接 (shielding version)

Raising screening braid equally over perimeter.
沿四周等长的翻起屏蔽编织。

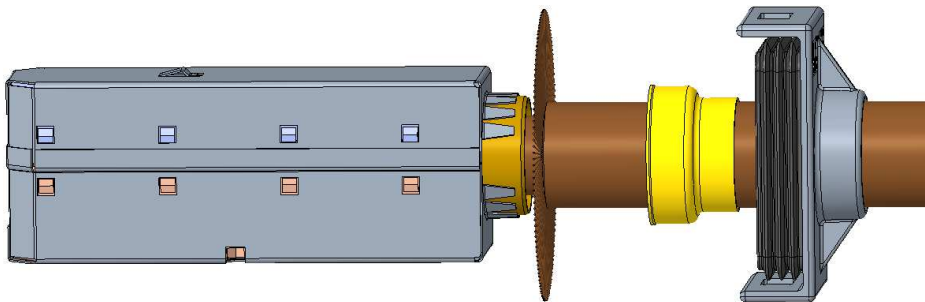

Figure 10: Raising screening braid

Insert Shield crimp ferrule oriented to contact until it stops against and keep touch with the upper shield and lower shield. And turn over screening braid by lateral movement.
沿端子方向套上屏蔽环直到与抵住屏蔽壳。并横向翻折屏蔽编织。

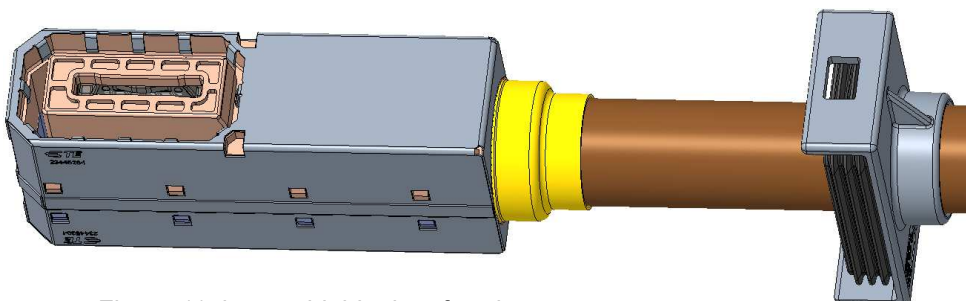

Figure 11: insert shield crimp ferrule



It is essential that there are no mistakes in this step because there will be no chance to re-work the parts.
在这一步中没有错误是至关重要的，因为无法重新加工。

The following items at minimum must be inspected and verified, before shield crimp process.

- All components are present, and parts are crimped in correct orientation and location
- No visible cracking of the shielding parts and no loose cable shield strands
- Hex or Round crimp dimensions per figure 10 and table 8
- Excess length of screening braid must be visible max. 1mm
- Allocation of screening braid should be equal over perimeter

在屏蔽压接前，必须至少检查并验证以下项目：

- 所有部件完整，部件以正确的方向和位置进行压接
- 屏蔽部件没有明显的开裂，也没有松散的电缆屏蔽线
- 每个压接尺寸依据图12和表8的六角形或圆形
- 屏蔽编织的长度必须可见最大1毫米
- 屏蔽编织应该均匀分配在四周

Shield crimp specification

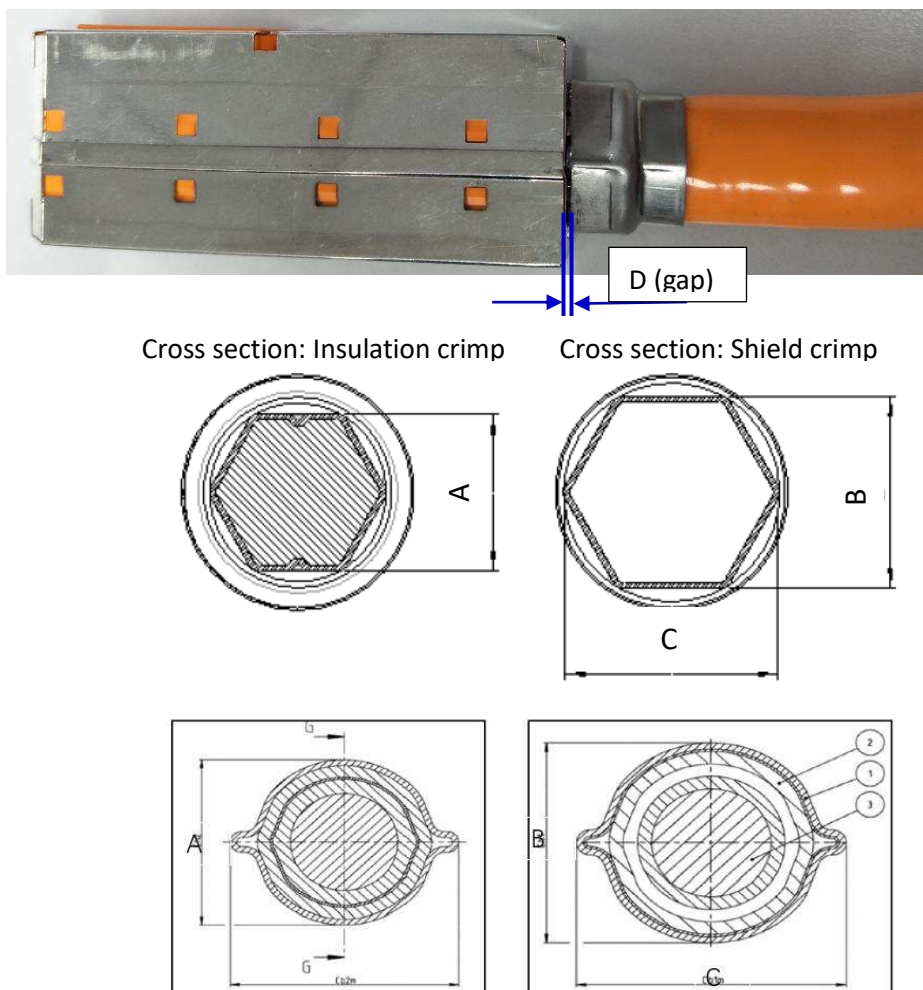

Figure 12: Crimped shield crimp ferrule

Table8: Shield crimped dimensions

Cross Section (mm ²)	A ± 0.15 (mm)	B ± 0.15 (mm)	C (mm)	D (mm)	Type
70	17.9	20.9	Max. 26	Max. 1	Hexagon
95	20.2	21.5	Max. 26	Max. 1	Hexagon
70	17.00	21.30	Smaller than shielding shell	Max. 1	Round
95	19.75	21.50	Smaller than shielding shell	Max. 1	Round
50	15.4	20.6	Max. 26	Max. 1	Hexagon

5.3 Plug Housing 母端壳体

5.3.1 Insert cable assembly into the Plug Housing 线缆组件装入母端壳体

Note the alignment of plug housing subassembly and cable assembly as shown figure 13.
注意，如图13所示，线缆组件与母端壳体组件界面对齐

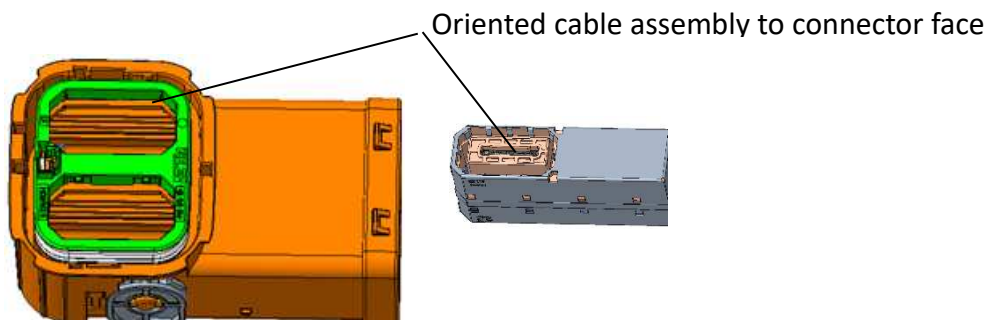

Figure 13: Oriented cable assembly to housing

Insert aligned the cable assembly into the plug subassembly until it stops against the inside of the housing and it makes "Click".

插入将线缆组件插入母端壳体组件，直到抵住外壳内部并发出“咔嚓”声。

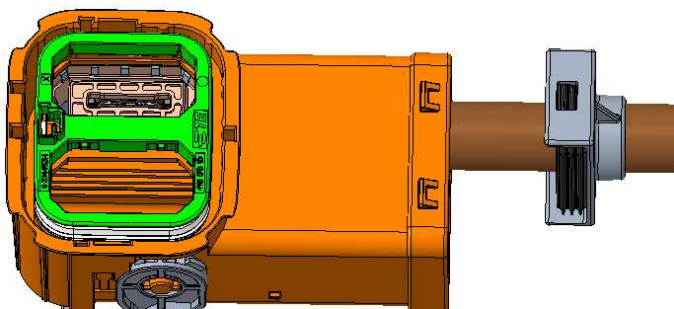

Figure 14: Insert cable assembly into the plug housing

5.3.2 Assemble cable seal assembly 组装线材密封组件

Slide cable seal assy onto plug housing until it is fully locked and makes "click". The following items at minimum must be inspected and verified:

Visual Examination of correct assembling cable seal assy into housing.

滑动线缆密封组件到母端壳体上知道完全扣住并发出“咔嗒”声。必须至少检查并验证以下项目：
目视检查正确组装线缆密封组件到外壳。

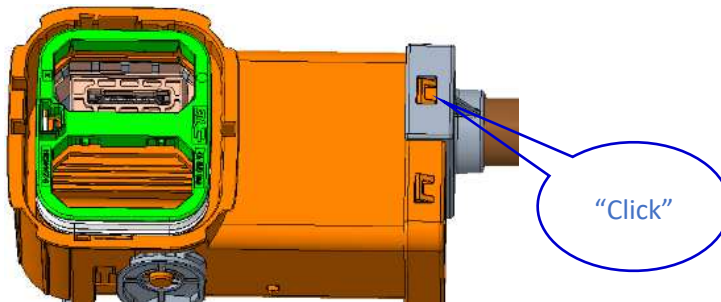

Figure 15: Assemble cable seal assy

5.3.3 Press TPA to end-lock position TPA 压到终锁位

Please note, after two position cable assy were fully assembled. Press TPA until it stops against the plug housing. Pressing smoothly indicates that the cable assy has been assembled in the correct position, otherwise the cable assembly and TPA status should be checked.

请注意，两位线缆组件安装完成后。下压TPA到终止位置。下压顺利说明线缆组件已安装到正确位置，反之需检查线缆组件和TPA状态。

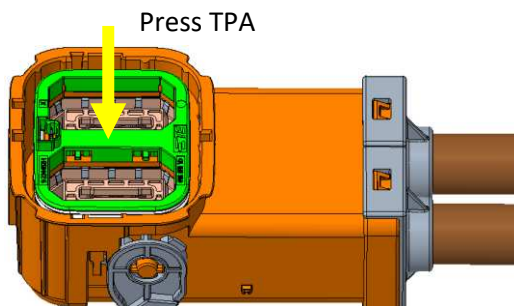

Figure 16: Press TPA

6. FINAL EXAMINATION 终检

6.1 Visual Examination 外观检查

After processing the connector assembly has to be checked of completeness, correctness acc. customer drawings and free of damage.

在装配连接器后，必须根据客户图纸进行完整性、正确性检查，且不能损坏。

6.2 Electrical Tests 电气测试

Electrical characteristic values according product specification TE-108-32326 / chapter 3.4 are ensured by applicator. The test parameter should be not exceeding the values shown in point 3.4/ TE-108-32326.

使用方依据产品规范TE-108-32326第3.4章保证电气特性。测试参数不应超出规范3.4章的值。

7. HEADER ASSY AND PLUG ASSY INSTRUCTIONS 公母端安装说明

7.1 Header assembly 公端安装

Application system requires installation panel, interface dimensions see latest customer drawing.
应用系统需有安装面板，界面尺寸请见最新客户图纸。

Following two steps can be adjusted depending on the actual application.
接下来的两个步骤可以根据实际应用进行调整。

1. Header assembled to the panel with 4 pieces M5 screw. The mounting screw with screw head / washer $\varnothing 9\text{mm}$ to $\varnothing 11\text{mm}$. Recommended tightening torque is $6\pm 0.5\text{NM}$
使用4枚M5螺丝固定公端到面板上。螺丝头和垫片的直径9~11毫米。建议安装扭矩 6 ± 0.5 牛米。

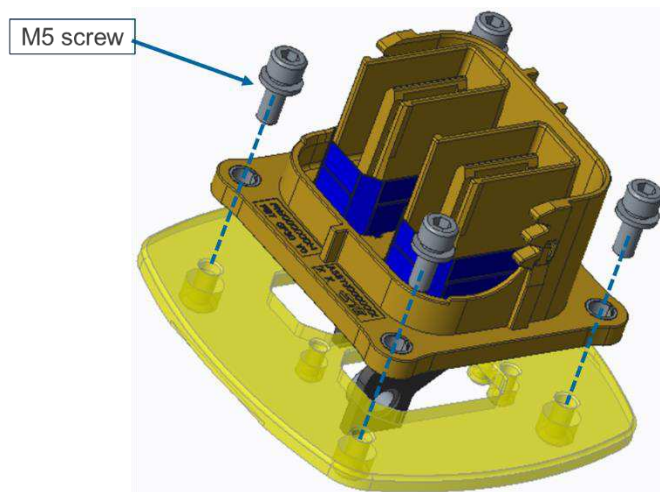

Figure 17: Assemble header to the panel

2. Inserting HVIL housing into the header. PNs of the HVIL housing and the HVIL contact please see customer drawing
安装高压互锁壳体，壳体和端子料号请见客户图纸。

After HVIL contacts crimped and assembled into HVIL housing, insert HVIL housing into header until it stopped.
高压互锁端子压接并插入高压互锁壳体后，插入公端直到止位。



Attention: HVIL need to be installed once, not two or more installations.
高压互锁需一次安装完成，不可二次或多次安装

HVIL the installation direction should be as parallel to HVIL housing as possible to avoid oblique insertion
高压互锁安装方向需尽可能平行于高压互锁壳体，避免倾斜插入

PS: If the above cannot be achieved due to space limitations during the installation process, a tool can be added to assist in completing the installation. The tool needs to be confirmed with TE

PS: 若安装过程中受空间限制无法做到以上，可增加治具辅助完成安装，治具需要与TE确认

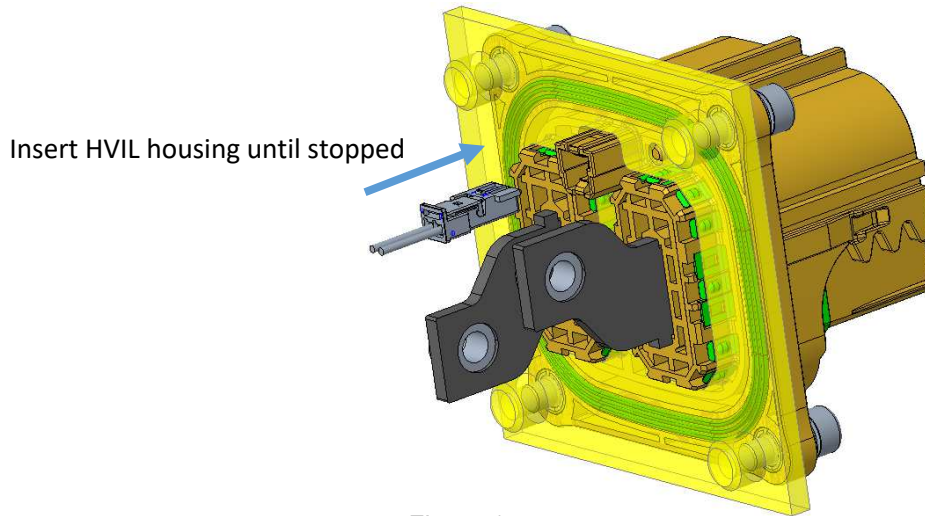

Figure 17: Insert HVIL housing

7.2 Plug assembly 母端安装

Delivery condition with lever and CPA are in locked position. Release of the CPA by shifting CPA along the arrow-direction.

杠杆和CPA的交付条件是处于锁定位置。通过沿箭头方向移动CPA来打开CPA。

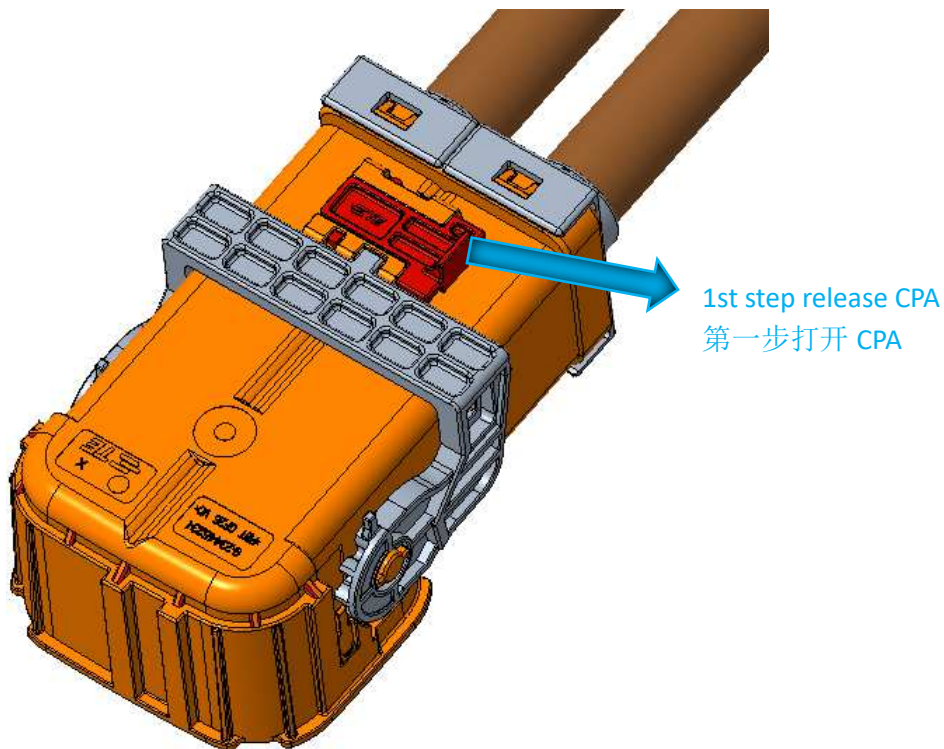

Figure 17: Delivery condition – CPA & lever locked

Rotate lever into plug position until vertical to plug housing and make audible “Click”, keep lever in open position.
旋转杠杆到插入位置直到与母端壳体垂直且发出“咔嗒”声,确保杠杆在起始位置.

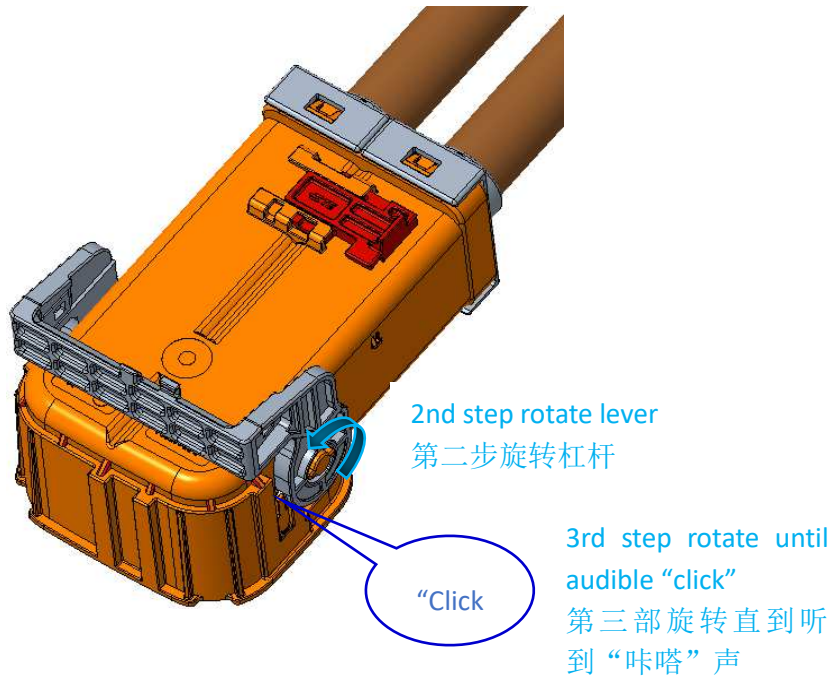

Figure 18: rotate into plug position

Mating of connector
连接器互配

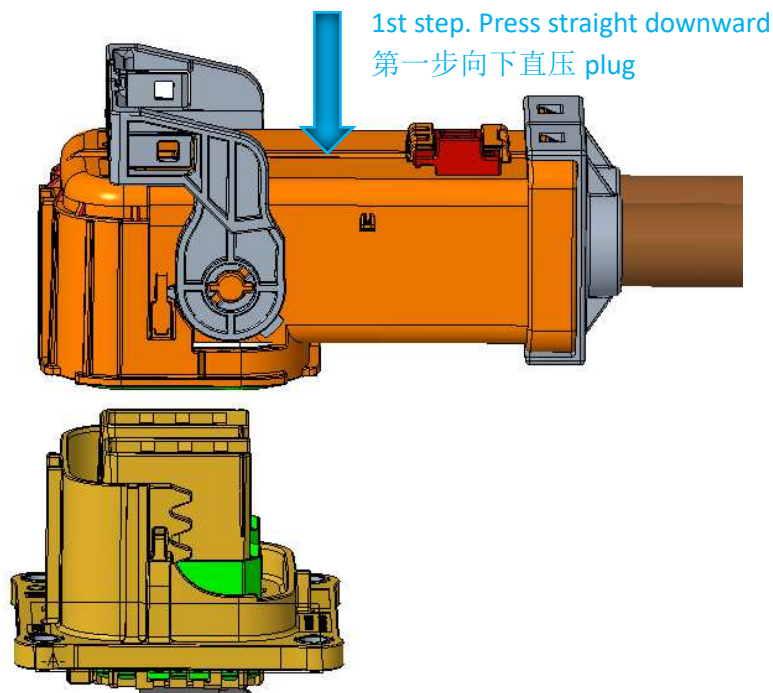

Figure 19: press plug downward

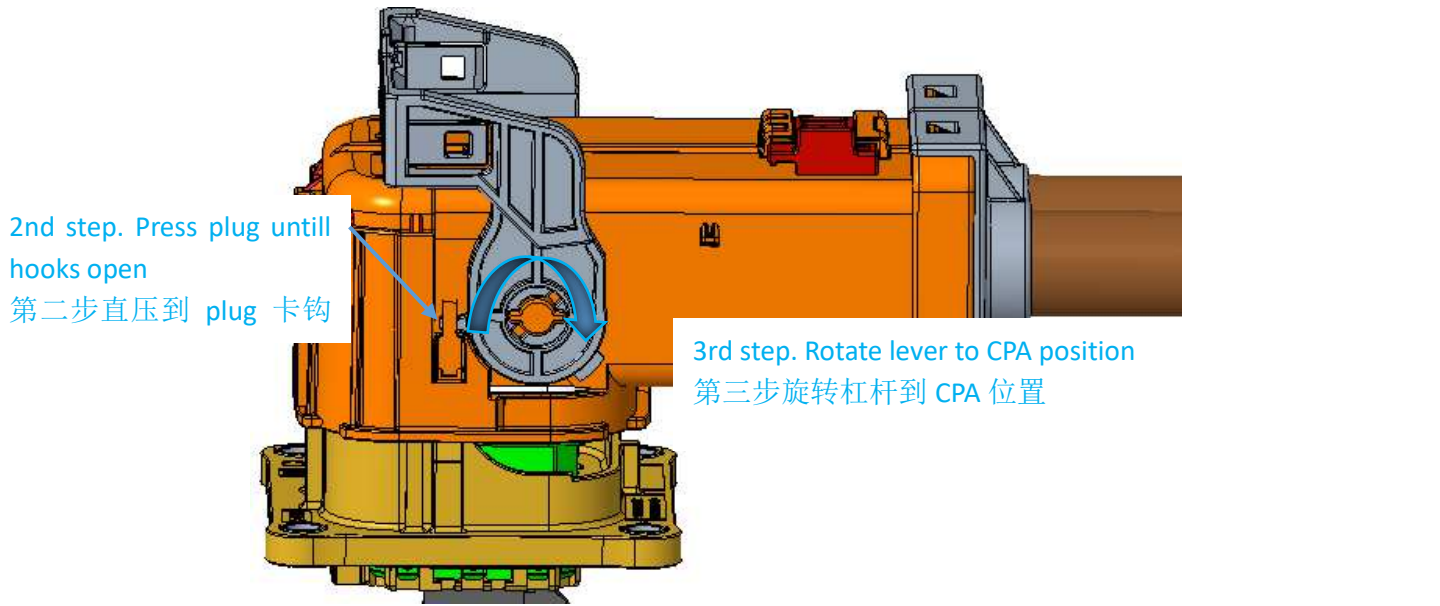

Figure 20: Rotate lever

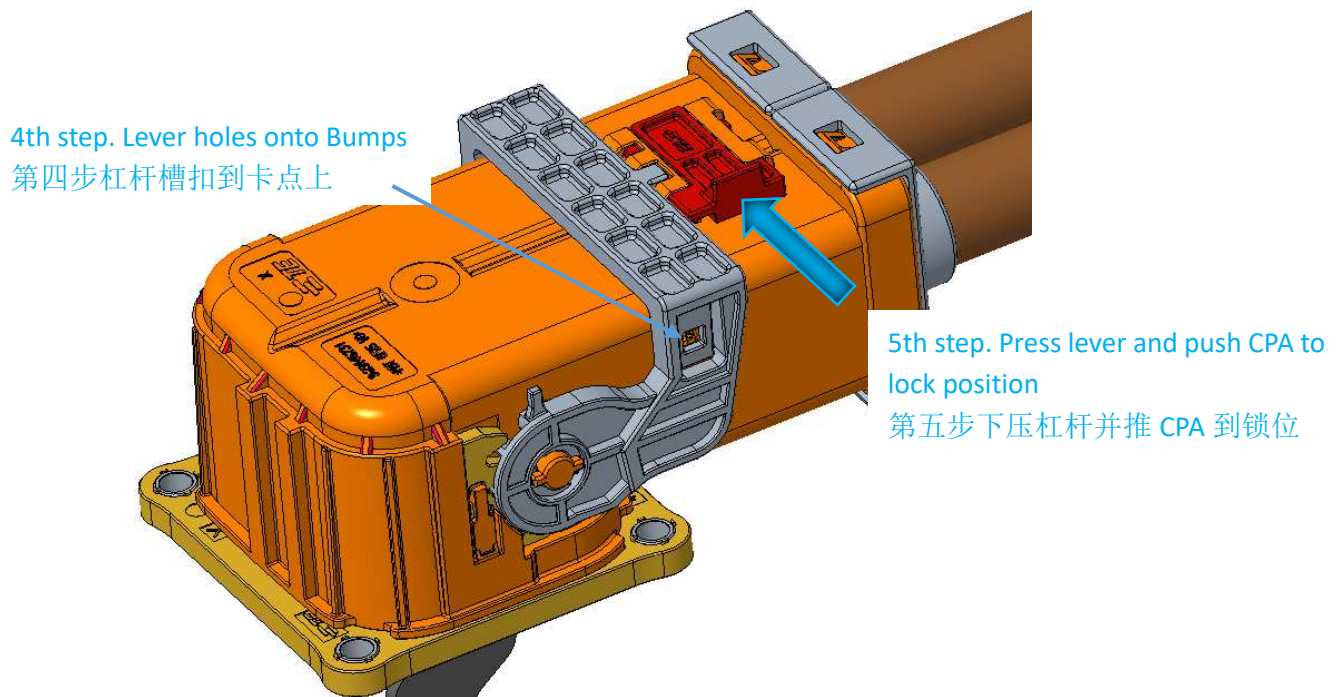

Figure 20: Lock CPA

8. APPENDIX 附录

8.1 Data sheets 数据表

8.1.1 XinHongYe shield cable 70 and 90mm² 鑫宏业 70 和 95 平方屏蔽线

No. TEVBA70-04-310 70mm² and 95mm² shield cable for PCON21 connector.
PCON21连接器采用物料编号TEVBA70-04-310 70mm²和95mm²屏蔽线

8.1.2 Force shield cable 50 and 70 and 95mm² 福斯 50 和 70 和 95 平方屏蔽线

No. FHLR2GCB2G 50mm² and 95mm² shield cable for PCON21 connector.
PCON21连接器采用物料编号FHLR2GCB2G 50mm²和70mm²和95mm²屏蔽线

8.1.3 KBE shield cable 70mm² KBE 70 平方屏蔽线

No. FHLR2GCB2G 70mm² shield cable for PCON21 connector.
PCON21连接器采用物料编号FHLR2GCB2G 70mm²屏蔽线

8.1.4 Coficab shield cable 70 and 95mm² COF 70 和 95 平方屏蔽线

No. FHLR91XC91X T4 ISO 70mm² and 95mm² shield cable for PCON21 connector.
PCON21连接器采用物料编号FHLR91XC91X T4 ISO 70mm²和95mm²屏蔽线

8.1.5 Force un-shield cable 70 and 95 mm² 福斯 70 和 95 平方非屏蔽线

No. GAC-QZJ-D 70mm² and No. FHL2G 95mm² unshield cable for PCON21 connector.
PCON21连接器采用物料编号GAC-QZJ-D 70mm²和FHL2G 95mm²非屏蔽线

8.1.6 HuaCheng shield cable 70mm² 华澄 70 平方屏蔽线

No. FHLR2GCB2G T180 70mm² shield cable for PCON21 connector.
PCON21连接器采用物料编号FHLR2GCB2G T180 70mm²屏蔽线

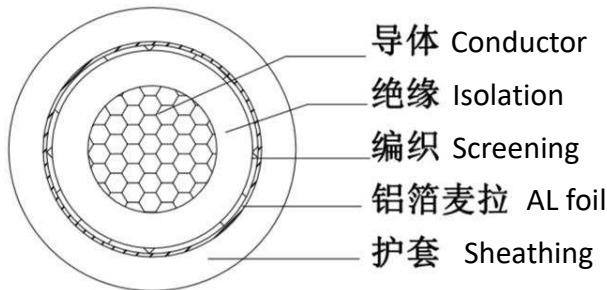

Region	Outer diameter(mm)				
	50mm ²	70mm ²	95mm ²	70mm ² (COF)	95mm ² (COF)
Conductor	Max.10.5	Max.12.5	Max. 14.8	Max.12.5	Max. 14.8
Isolation	11.85±0.35	13.7±0.7	16.5±0.7	13.7±0.7	16.0±0.7
Sheathing	15.5±0.3	17.8±0.4	20.5±0.4	17.0±0.4	19.5±0.4

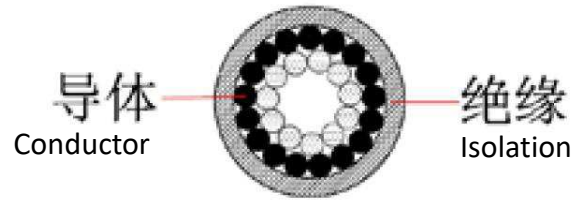

Region	Outer diameter(mm)	
	70mm ²	95mm ²
Conductor	Max.12.5	Max. 14.8
Sheathing	14.7±0.4	16.9±0.5