

NOTE

All numerical values are in metric units [with U.S. customary units in brackets]. Dimensions are in millimeters [and inches]. Unless otherwise specified, dimensions have a tolerance of ± 0.13 [.005] and angles have a tolerance of $\pm 2^\circ$. Figures and illustrations are for identification only and are not drawn to scale.

1. INTRODUCTION

This specification covers the requirements for application of AMPLIMITE III Series 318 and 590 All-Plastic Right-Angle Plug and Receptacle Connectors that are designed for printed circuit (pc) board applications. Each connector consists of an all-plastic housing and formed solder post contacts. The plugs contain pin contacts and receptacles contain socket contacts. These connectors are designed to be positioned on a pc board by hand or by robotic equipment.

There are plug and receptacle connectors available in 9, 15, 25, and 37 positions. All are available with or without nonremovable threaded inserts, screwlocks, and boardlocks. Refer to Figure 1 for connector features that will be referred to throughout this specification. Use these terms when corresponding with AMP Representatives to facilitate assistance. Note that the illustrations represent a composite of available mounting options. On a typical connector, hardware and mounting configurations will be identical on both sides.

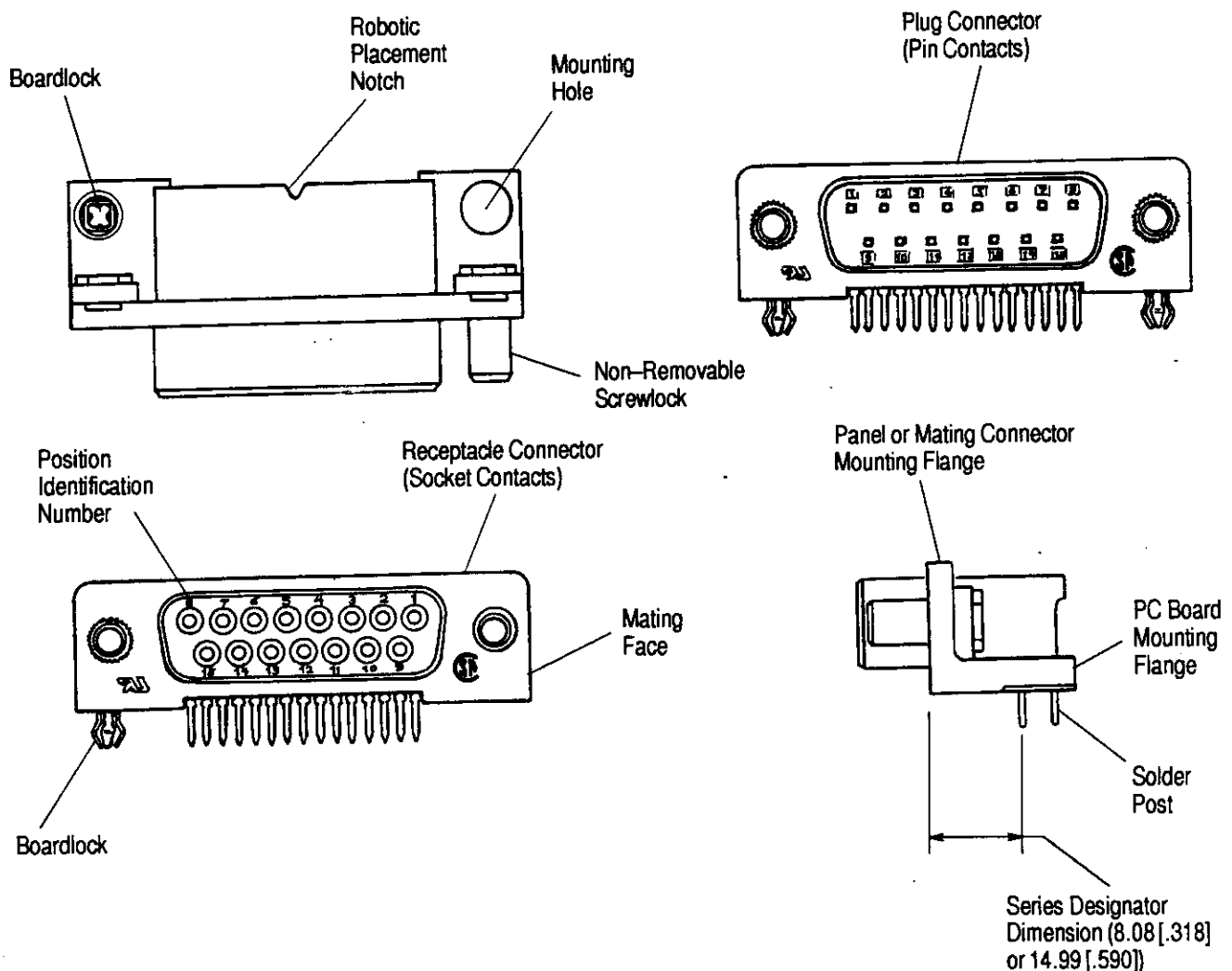

Figure 1

115-147

2. REFERENCE MATERIAL

2.1. Revision Summary

This paragraph is reserved for a revision summary covering the most recent additions and changes made to this specification which include the following:

Per EC 0020-0947-94:

- Added torque limits to Paragraph 3.8.A and 3.8.B

Per EC 0990-7823-92

- Updated format
- Added metric units
- Added Revision Summary to Section 2
- Renumbered Sections 2 and 3
- Added Storage Information to Section 3
- Added new solder cleaners in Paragraph 3.9

2.2. Customer Assistance

Reference Part Number 173944 and Product Code 4301 are representative numbers that identify the AMPLIMITE III All-Plastic Right-Angle Connectors. Use of these numbers will identify the product line and expedite your inquiries through an AMP service network established to help you obtain product and tooling information. Such information can be obtained through a local AMP Representative (Field Sales Engineer, Field Applications Engineer, etc) or, after purchase, by calling the Technical Assistance Center or the AMP FAX/Product Information Center number at the bottom of page 1.

2.3. Drawings

AMP Customer Drawings for each product part number are available from the service network. The information contained in Customer Drawings takes priority if there is a conflict with this specification or with any technical documentation supplied by AMP Incorporated.

2.4. Specifications

- A. AMP Product Specification 108-1226 provides product performance requirements and test information.
- B. Application Specifications 114-40028 contain design, inspection and assembly procedures for AMPLIMITE III Series 318 and 590 Metal Shell Connectors

2.5. Bulletin

AMP Corporate Bulletin No. 52 is available upon request and can be used as a guide in soldering. This bulletin provides information on various flux types and characteristics along with the commercial designation and flux removal procedures. A checklist is attached to the bulletin as a guide for information on soldering problems.

3. REQUIREMENTS

3.1. Storage

A. Ultraviolet Light

Prolonged exposure to ultraviolet light may deteriorate the chemical composition used in the connector housings.

B. Heat Limitation

The heat limitation for AMPLIMITE III connectors is 220°C [428°F].

C. Shelf Life

The connectors should remain in the shipping containers until ready for use to prevent deformation to the connectors. The connectors should be used on a first in, first out basis to avoid storage contamination that could adversely affect signal transmissions.

3.3. Mating Dimension

The dimension in Figure 3 is required to ensure full mating of connectors. This dimension must be considered when determining the method of mounting and the thickness of a panel when the connector is to be panel mounted.

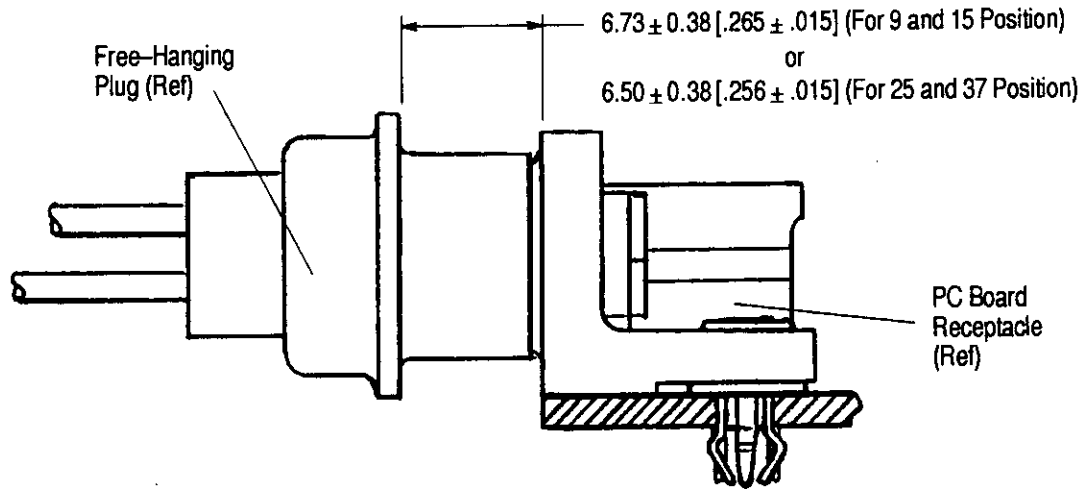
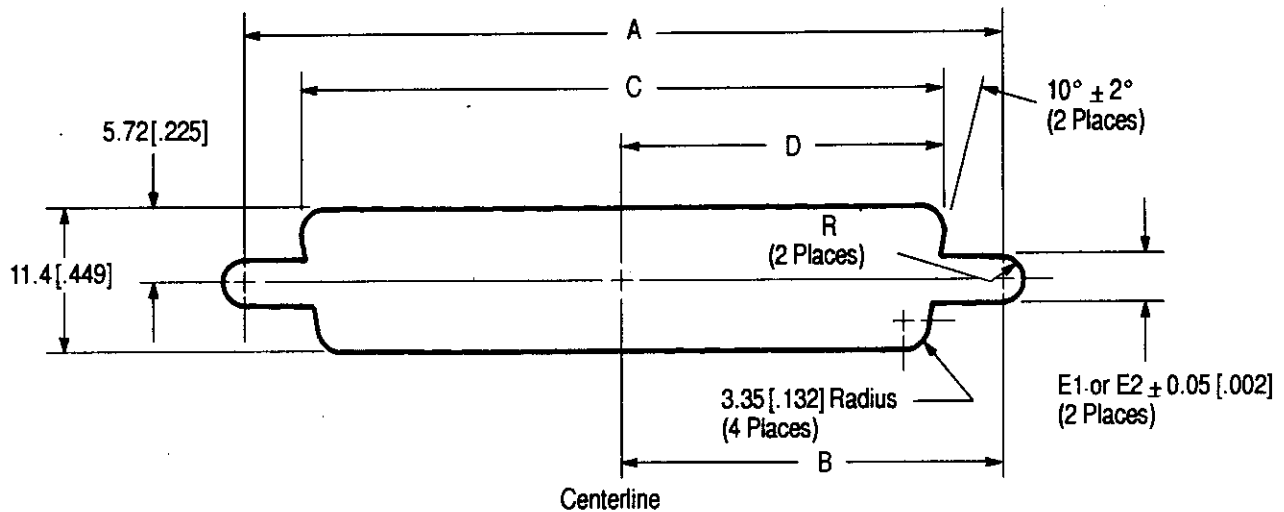

Figure 3

115-148

3.4. Panel Mounting

Rear panel mounting is recommended to provide additional stability for mating and unmating of connectors. Figure 4 provides the panel mount dimensions for correct placement of a connector in a panel.



NUMBER OF CONNECTOR POSITIONS	DIMENSION					
	A	B	C	D	E1	E2
9	24.99 [.984]	12.5 [.492]	20.47 [.806]	10.24 [.403]	3.05 [.120]	4.83 [.190]
15	33.32 [1.312]	16.66 [.656]	28.8 [1.134]	14.4 [.567]	3.05 [.120]	4.83 [.190]
25	47.04 [1.852]	23.52 [.926]	42.52 [1.674]	21.26 [.837]	3.05 [.120]	4.83 [.190]
37	63.5 [2.500]	31.75 [1.250]	59.08 [2.326]	29.54 [1.163]	3.05 [.120]	4.83 [.190]

E1 Use this dimension when hardware is used to secure the connector to a panel.

E2 Use this dimension when screwlocks are pre-installed but not used to secure the connector to a panel.

Figure 4

3.5. Limitations

Use the AMP Product Specification referenced in Paragraph 2.4 for test procedures regarding these connectors.

3.6. Polarizing and Keying

By their very design, the AMPLIMITE III Plug and Receptacle Connectors are polarized. The keystone configuration of the mating face prohibits the accidental inversion of mating connectors. To further reduce the possibility of incorrect installation of mating plug connectors, a keying plug may be placed in the receptacle connector. See Figure 5.

NOTE

If a keying plug is used, the pin cavity in the mating connector must be empty.

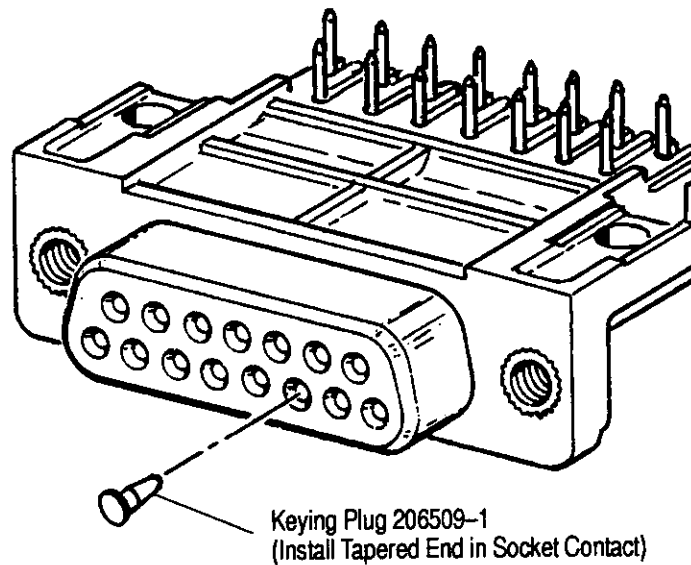

Figure 5

115-149

3.7. Methods of Attaching Connector to PC Board

The connector should be secured to the pc board prior to soldering. This can be done by using any of the following methods:

A. Standard Connectors

Attach connectors to pc board with commercially available screws, washers, and nuts, rivets or similar devices. The hardware should be attached prior to soldering and soldered in place when the solder posts are soldered.

B. Boardlock Connectors

Each boardlock has two gripping shoulders that lock into position as the solder posts are inserted into the pc board. The initial insertion and extraction forces are: 62 N [14 pounds] maximum for insertion and 13 N [3 pounds] minimum for extraction.

3.8. Ancillary Items

A. Screwlocks

Connectors with non-removable screwlocks provide a means of securing mating connectors with commercially available 4-40 hardware. The torque limit is .68 N•m [6 inch-pounds] applied from the mating face side. The maximum pushout force is 89 N [20 pounds], applied from the mating face side.

B. Threaded Inserts

Nonremovable threaded inserts provide a means for panel mounting the pc board connector using commercially available 4-40 threaded hardware. The torque limit is .68 N•m [6 inch-pounds] applied from the mating face side. The maximum pushout force is 89 N [20 pounds], applied from the mating face side.

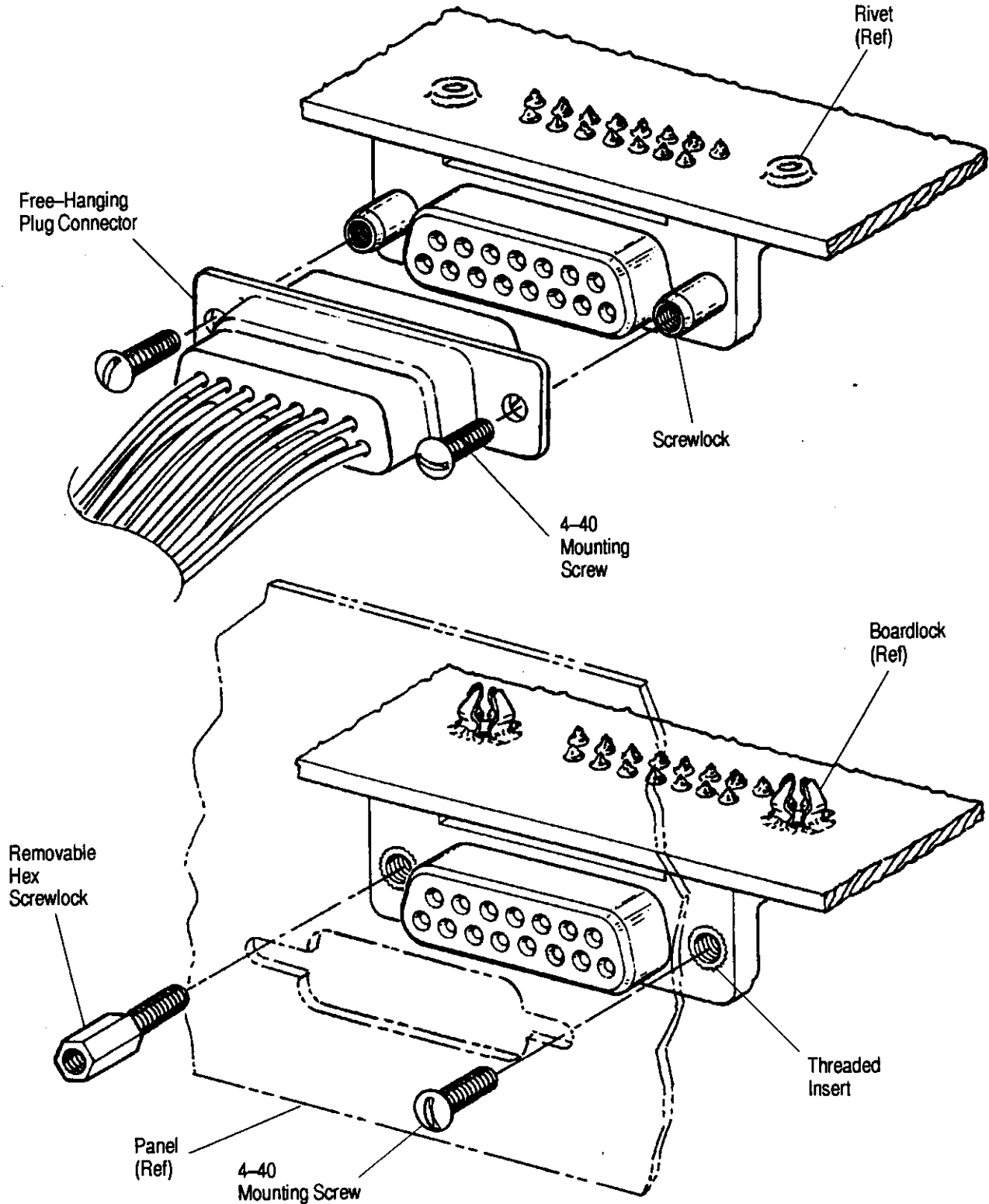

Figure 6

115-150

3.9. Soldering

A. Flux Selection

The connector solder tails and attaching hardware must be fluxed prior to soldering with a rosin base flux. Selection of the proper flux will depend on the type of pc board and other components, if any, mounted on the board. Additionally, the flux will have to be compatible with the wave solder line, manufacturing, and safety requirements.

B. Cleaning

Removal of fluxes, residues, and activators is mandatory. Cleaning procedures depend on the type of flux used on the solder line. The following cleaning compounds will not adversely affect the housings or contacts.

CLEANER		TIME (Minutes)	TEMPERATURES (Maximum)	
NAME	TYPE		CELSIUS	FAHRENHEIT
Alpha 2110■	Aqueous	1	132	270
Bioact EC-7◆	Solvent	5	100	212
Carbitol●	Solvent	1	Room Ambience	
Isopropyl Alcohol	Solvent	5	100	212
Kester 5778⚡	Aqueous	5	100	212
Kester 5779⚡	Aqueous	5	100	212
Lonco 520●	Aqueous	5	100	212
Lonco 530●	Aqueous	5	100	212
Terpene Solvent	Solvent	5	100	212

■ Product of Fry's Metals, Inc. ◆ Product of Petroferm, Inc. ● Product of Union Carbide Corp. ⚡ Product of Litton Systems, Inc.

Figure 7

DANGER *Consideration must be given to toxicity and other safety requirements as recommended in the Material Safety Data Sheet supplied by the solvent manufacturer. Trichloroethylene and Methylene Chloride can be used with no harmful affect to the connectors; however, AMP does not recommend them because of the harmful occupational and environmental effects. Both are carcinogenic (cancer-causing) and Trichloroethylene is harmful to the earth's ozone layer.*

NOTE *If you have a particular solvent that is not listed, contact the Technical Assistance Center or Product Information number at the bottom of page 1.*

C. Drying

When drying cleaned assemblies and pc boards, make certain that temperature limitations of -55° to 105° C [-67° to 221° F] are not exceeded. Excessive temperatures may cause housing degradation.

D. Soldering Guidelines

Refer to Paragraph 2.5 for instructional material that is available for establishing soldering guidelines.

4. QUALIFICATION

AMPLIMITE III Series 318 and 590 All-Plastic Right-Angle Plug and Receptacle Connectors are UL component recognized under file E28476 and E81956. They are also certified under CSA file LR7189.

5. TOOLING

No special tooling is required for hand placement of the connector on the pc board.

6. VISUAL AID

Figure 8 shows typical AMPLIMITE III All-Plastic Right-Angle Connectors after they have been installed and soldered onto a pc board. The composite illustration shows visual conditions which ensure a proper installation.

NOTE

A composite of various types of hardware is shown to illustrate the available options. In an actual application, the hardware used for connector mating will be identical, as will be the hardware used for pc board mounting.

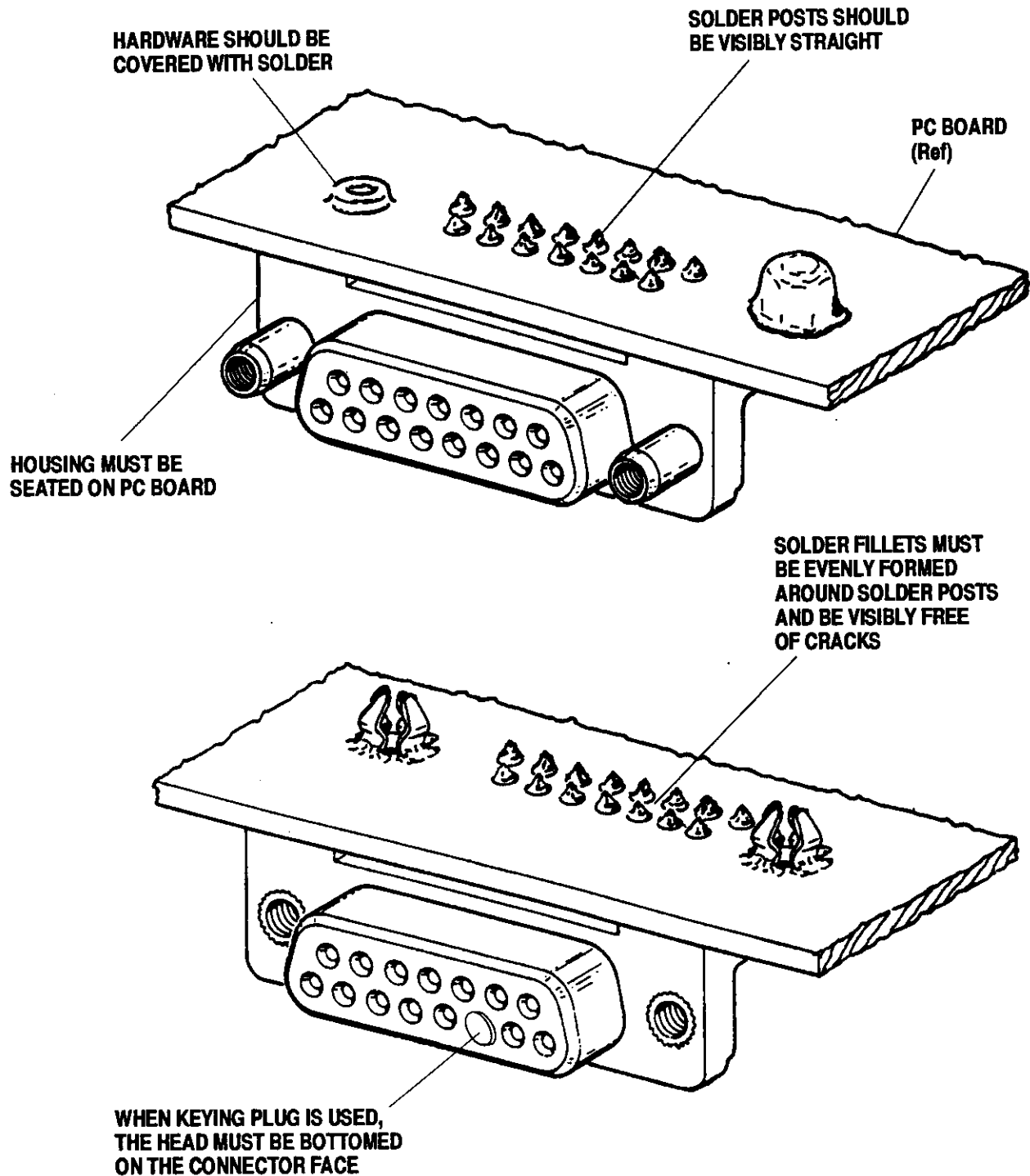
**FIGURE 8. VISUAL AID**

115-151