



All numerical values are in metric units [with U.S. customary units in brackets]. Dimensions are in millimeters. Unless otherwise specified, dimensions have a tolerance of ± 0.13 and angles have a tolerance of $\pm 2^\circ$. Figures and illustrations are for identification only and are not drawn to scale.

1. INTRODUCTION

This specification covers the requirements for application of ECU-1 plug connector and header assembly, which provide high-density input/output connections for Ford Motor Company's Enhanced Electronic Engine Control Module Series V (EECV). The plug connector accepts socket contacts and the right-angle header assembly contains solder contacts and provides a 90-degree printed circuit (pc) board connection.

The plug connector and header assembly are sealed and available in a 104-contact cavity position. For applications requiring less than 104 circuits, unused plug circuits can be selectively blocked by using the appropriate seal plugs. The plug connector and header assembly are keyed to prevent mismatching, and the socket contacts are positively locked into the plug connector using a true position spacer to assure proper seating. The wire shield protects the wires and provides strain relief. The wire shield is available in end exit, vertical exit, T-shaped, side open box, end left, and end right wire dressings. The jack screw prevents the plug connector and header assembly from unmating. A gasket is available that helps prevent water intrusion.

When corresponding with personnel, use the terminology provided in this specification to facilitate your inquiries for information. Basic terms and features of this product are provided in Figure 1.

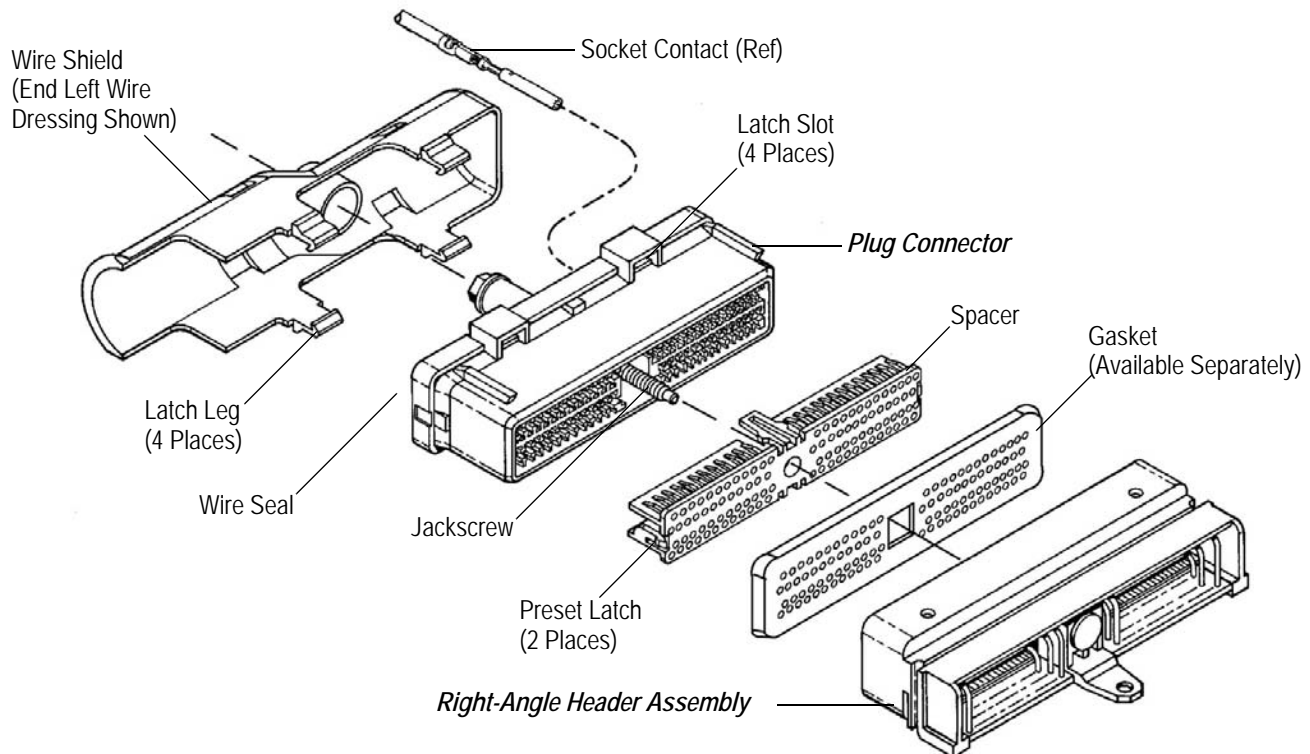

Figure 1

2. REFERENCE MATERIAL

2.1. Revision Summary

Changes to this application specification include:

- Changed company name and logo

- Replaced superceded part number in Paragraph 2.2
- Modified Paragraphs 2.3 and 3.3 and Section 5, and added Paragraphs 3.1 and 3.2
- Added unmating procedure to Paragraph 3.6 and removal procedure to Paragraph 3.10
- Added requirements to Section 6

2.2. Customer Assistance

Reference Product Base Part Number 776557 and Product Code 2154 are representative of ECU-1 plug connector and header assembly. Use of these numbers will identify the product line and expedite your inquiries through a service network established to help you obtain product and tooling information. Such information can be obtained through a local Representative or, after purchase, by calling PRODUCT INFORMATION at the number at the bottom of page 1.

2.3. Drawings

Customer Drawings for this product are maintained by Ford Motor Company in Dearborn, Michigan. If there is a conflict between the information contained in this specification or with any other technical documentation supplied by TE Connectivity, the customer drawings from Ford Motor Company takes priority.

2.4. Specifications

Application Specification 114-6071 provides product description and application requirements of ECU-1 1-mm socket contacts used in the ECU-1 plug connector.

2.5. Instructional Material

Instruction Sheets (408-series) provide product assembly instructions or tooling setup and operation procedures and Customer Manuals (409-series) provide machine setup and operating procedures. There are no documents available that pertain to this product.

3. REQUIREMENTS

3.1. Safety

Do not stack product shipping containers so high that the containers buckle or deform.

3.2. Storage

A. Ultraviolet Light

Prolonged exposure to ultraviolet light may deteriorate the chemical composition used in the plug connector and header assembly material.

B. Shelf Life

The plug connector and header assembly should remain in the shipping containers until ready for use to prevent deformation to the contacts or other parts. The plug connector and header assembly should be used on a first in, first out basis to avoid storage contamination that could adversely affect performance.

3.3. Wire Selection

These plug connectors will accept cable sizes 18 and 20 AWG. Certain plug connectors will seal properly with Ford Motor Company ESB-M1L123-A low tension stranded cable insulated with cross-linked polyethylene, and other plug connectors will seal properly with WSS-M1L135-A1 low tension stranded cable vinyl insulated with a non-coated conductor.

3.4. Assembly



The seal cover must not be removed or altered in any way.

1. The spacer must be in the **open** (as-shipped) position before inserting any contacts. The contact cavity retention fingers will not engage if contacts are inserted while the spacer is in the closed position.

2. Each contact must be pushed straight into the appropriate contact cavity as far as possible. The wire of the contact must be pulled using a force between 8.9 and 13.3 N [2 to 3 lbs] to ensure the contact cavity retention finger is holding the contact in place. See Figure 2.

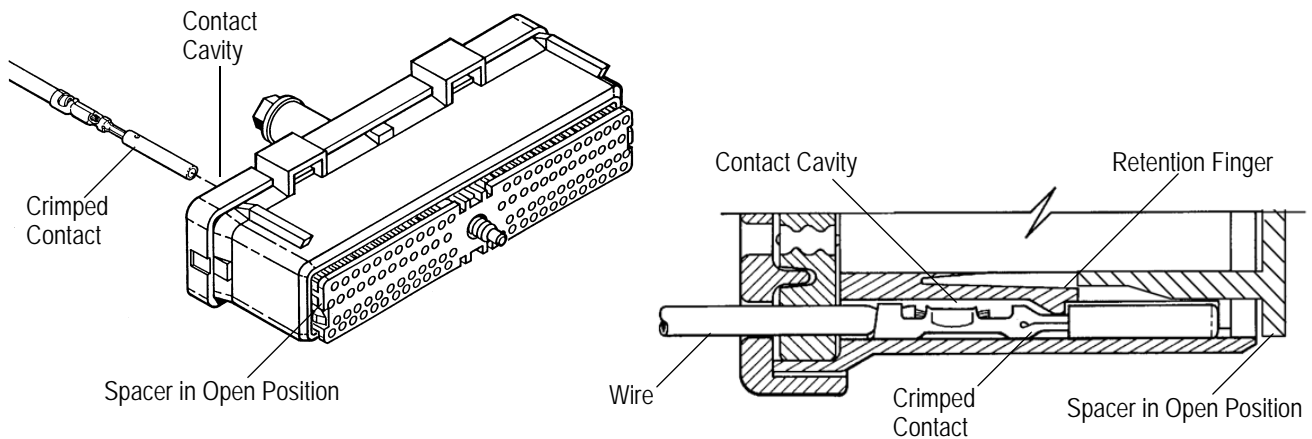

Figure 2

3. After all required contacts have been inserted, the spacer must be closed to its locked position. The locking latches must be released by squeezing them inward and sliding the spacer forward until it is flush with the housing. See Figure 3.

NOTE



The spacer should seat using a maximum force of 56 N [12.5 lbs]. If the spacer does not seat, it must be verified that all contacts are fully inserted.

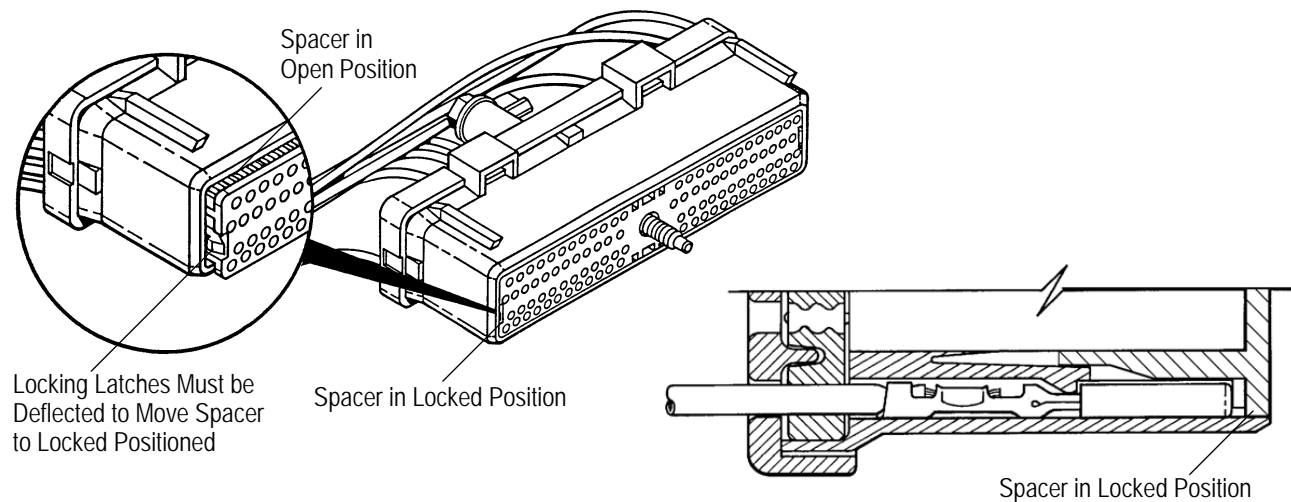

Figure 3

CAUTION



The back of the plug connector must be completely sealed. These plug connectors are available with seal covers that have selectively blocked contact cavities. Contact cavities that are not blocked must contain a contact crimped to a wire.

4. The wire shield must be assembled over the wires and onto the wire side of the plug connector. No wires can be pinched between the wire shield and the plug connector. See Figure 4.

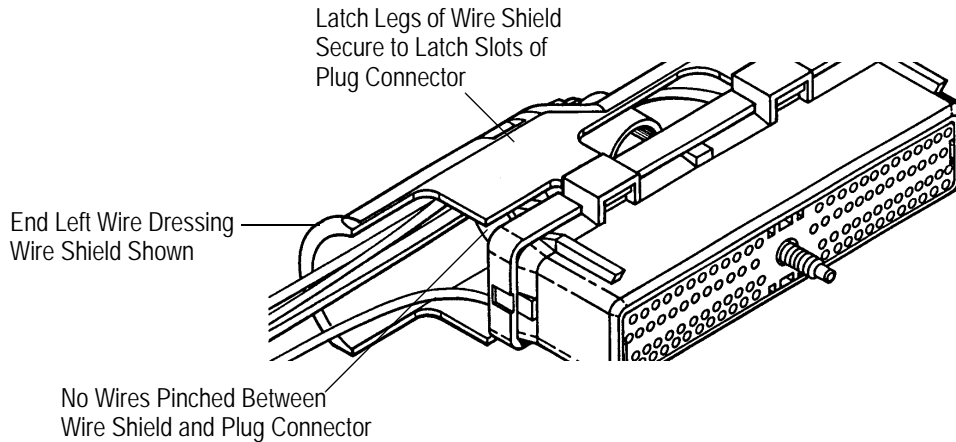

Figure 4

3.5. PC Board Thickness and Layout

The pc board thickness shall be 1.57.

The pc board holes must be precisely located to ensure proper placement and optimum performance. The pc board must be designed using the dimensions provided on the customer drawing for the specific header assembly. A sample pc board layout is shown in Figure 5.

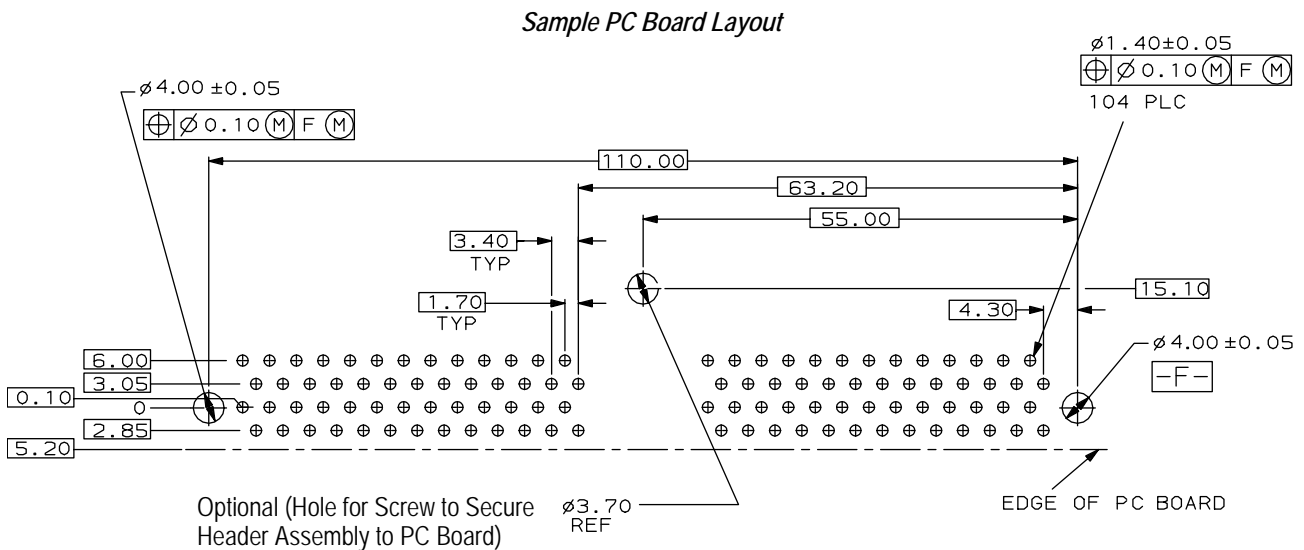

Figure 5

3.6. Mating and Unmating

When mating the plug connector to the header assembly, the plug bolt must be torqued to 4.8 ± 0.8 Nm [3.5 ± 6 ft-lbs]. Application of torque beyond this range could damage the system.

The plug connector and header assembly must be unmated by removing the plug bolt, then rocking the plug connector and header assembly apart. It is recommended that one end should be free, but should not be pulled more than 5 degrees before rocking the same end back. This will release the opposite end, and the two plug connector and header assembly will be separated.

3.7. Disassembly

1. The shield wire cover must be removed by releasing the four latch legs from the latch slots of the plug connector. See Figure 6.

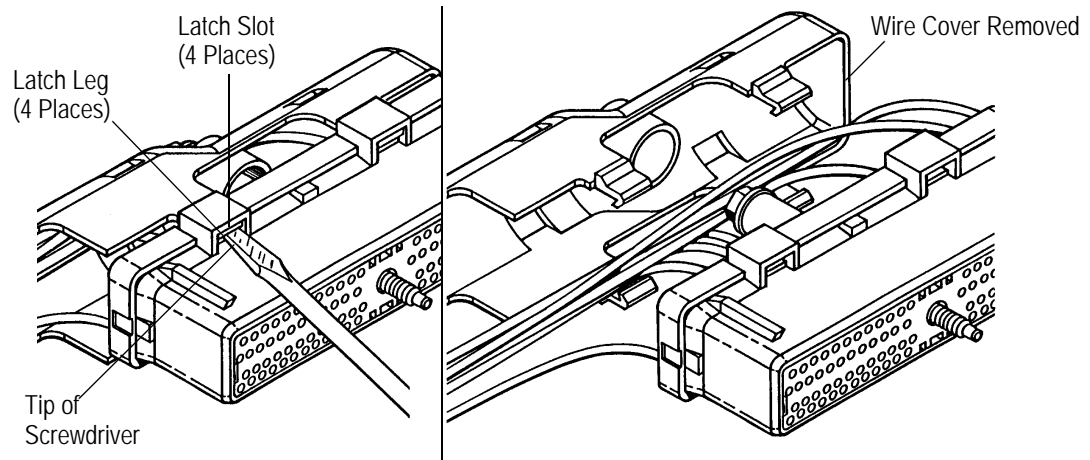

Figure 6

2. A hooked tool or modified 3.18-mm flat blade screwdriver must be inserted into the opening on either side of the jackscrew. Refer to Section 5 for screwdriver and hooked tool dimensions. The tool must be rotated 90 degrees, and the spacer must be pulled straight out from the plug connector. See Figure 7.



The tool must not pry against the wall of the housing; otherwise, damage to plug connector sealing could occur.

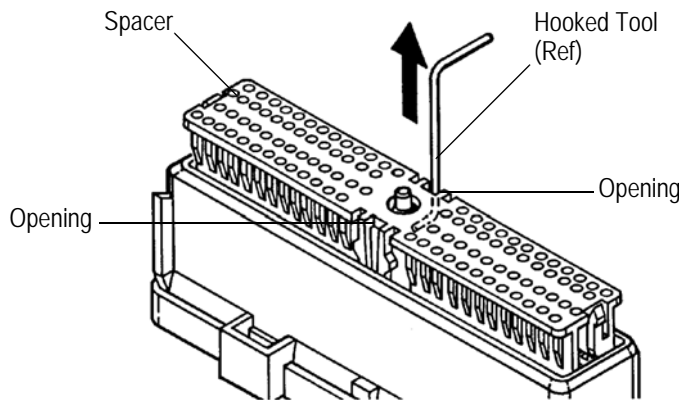

Figure 7

3. A 1.4-mm flat blade screwdriver must be inserted into the contact cavity so that the retention finger holding the contact is deflected. The wire must be gently pulled until the contact is free from the housing. This step must be repeated for the remaining contacts to be removed as shown Figure 8.

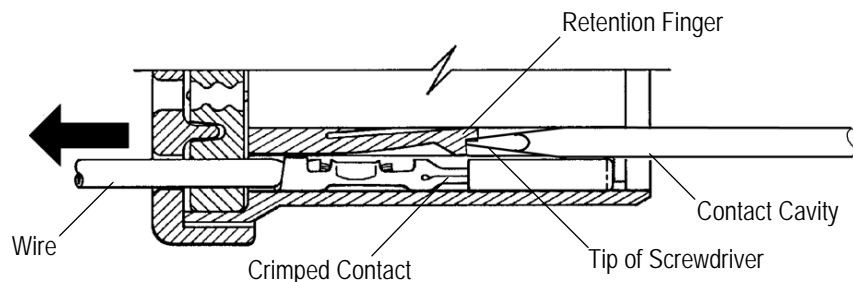

Figure 8

3.8. Circuit Testing

The spacer has a hole pattern in the mating end. These holes accommodate circuit test probes that are up to 1.55-mm in diameter, which will prevent damage to the contact. The test probe should contact the outer sleeve of the contact, but never enter the sleeve and touch the contact beams. Refer to Section 5 for recommended test probe design.

3.9. Voltage Reading During Service



The wire insulation must not be pierced to take voltage readings.

It has been common practice in electrical troubleshooting to probe wires by piercing the insulation with a sharp point. This practice must be strongly discouraged when dealing with the ECU-1 plug connector and any other sealed connector system. The resulting pin holes in the insulation will allow moisture to invade the system by traveling along the wire strands. This nullifies the effectiveness of the plug connector seals and could result in system failure.

3.10. Replacement and Repair

Header assemblies may be removed from the pc board by standard de-soldering methods.

4. QUALIFICATION

The ECU Series-1 plug connector and header assembly do not require agency approval.

5. TOOLING

No tooling is required to place header assemblies on the pc board.

A 1.4-mm flat blade screwdriver must be used to remove each contact from the plug connector.

A hooked tool or modified 3.18-mm flat blade screwdriver must be used to remove the spacer from the plug connector. Dimension are given in Figure 9.

A test probe up to 1.55-mm in diameter is required for circuit testing. Recommended test probe design is shown in Figure 9.

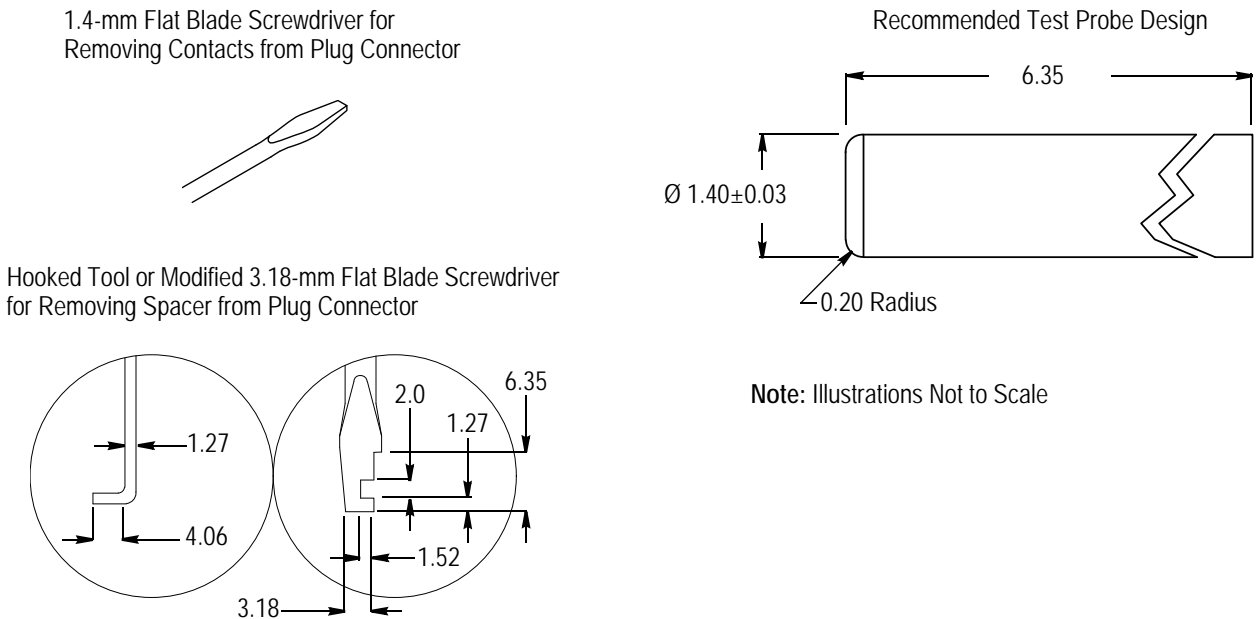

Figure 9

6. VISUAL AID

The illustration below shows a typical application of this product. This illustration should be used by production personnel to ensure a correctly applied product. Applications which DO NOT appear correct should be inspected using the information in the preceding pages of this specification and in the instructional material shipped with the product or tooling.

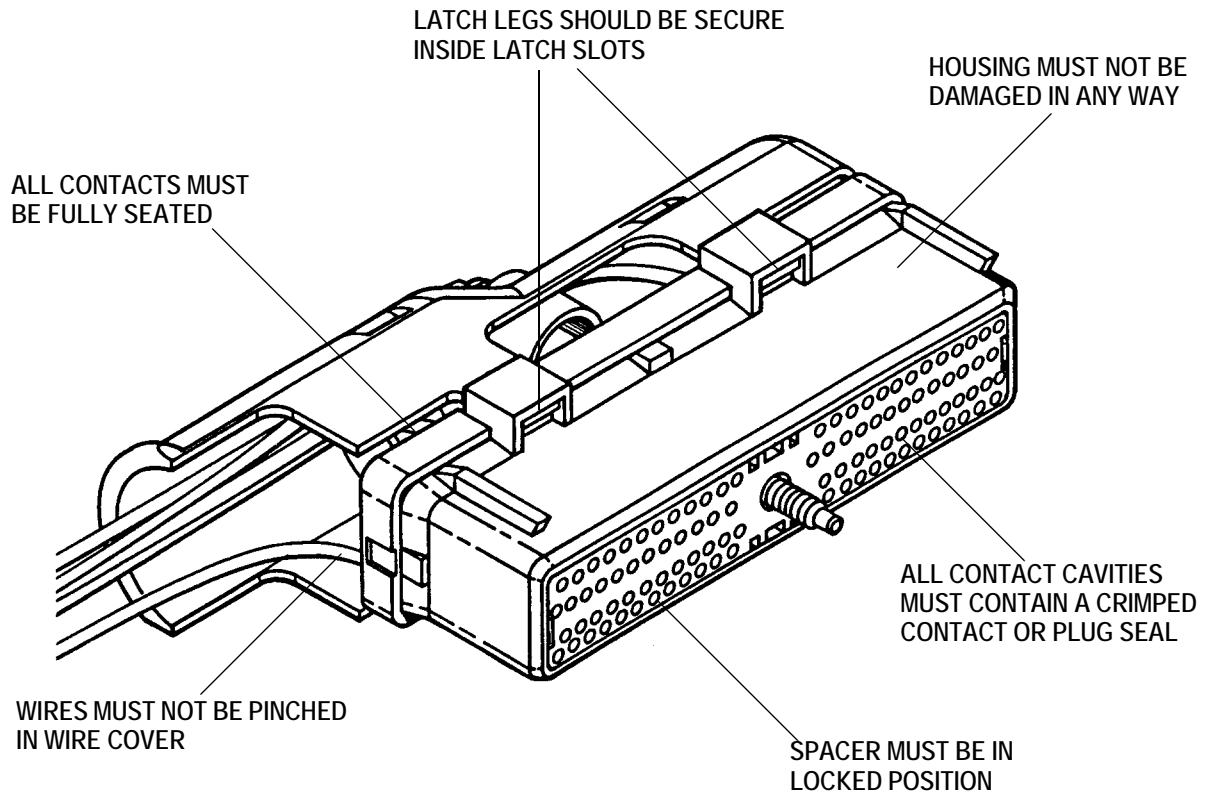

FIGURE 10. VISUAL AID