

---

**58 WAY ABS ESP CONNECTOR**

---

**TABLE OF CONTENTS**

- 1 GENERAL**
  - 1.1 PURPOSE
  - 1.2 CUSTOMER DRAWINGS / INTERFACE SPECIFICATION
  - 1.3 DELIVERY CONDITION OF CONNECTOR AND WIRE COVERS
  - 1.4 APPLICABLE COMPONENTS
  
- 2 CONNECTOR OPERATING INSTRUCTIONS**
  - 2.1 ASSEMBLY OF THE CONNECTOR
  - 2.2 TERMINAL INSERTION / REMOVAL INSTRUCTIONS
    - 2.2.1 TERMINAL INSERTION
    - 2.2.2 RETAINER (TPA) MOVING TO END-LOCKED POSITION
    - 2.2.3 RETAINER (TPA) MOVING TO PRE-LOCKED POSITION
    - 2.2.4 TERMINAL EXTRACTION
  - 2.3 WIRE OUTER DIAMETER REQUIREMENTS FOR SEALING (MAT SEAL)
  - 2.4 COVER MOUNTING / REMOVAL INSTRUCTIONS
    - 2.4.1 COVER MOUNTING
    - 2.4.2 COVER REMOVAL
  
- 3 CONNECTOR MATING / UNMATING ON / FROM AGGREGATE HEADER**
  - 3.1 CONNECTOR MATING
  - 3.2 CONNECTOR UNMATING
  
- 4 STORAGE CONDITIONS**
  
- 5 ELECTRICAL TEST CONTROL**
  
- 6 TOOLS DESIGN**
  
- 7 ACCESSORIES**

## 1 GENERAL

### 1.1 PURPOSE

This specification describes how to handle the 58 way connector and its components.

### 1.2 CUSTOMER DRAWINGS / INTERFACE SPECIFICATION

This application specification is based on the latest valid customer drawings.

C-2208656 FEMALE HOUSING ASSEMBLY, 58 WAY ABS CONNECTOR

C-2208653 WIRE COVER ASSEMBLY, CABLE EXIT 180°, 58 WAY ABS CONNECTOR

C-2354883 FEMALE HOUSING ASSEMBLY, 58 WAY ABS CONNECTOR

C-2177649 WIRE COVER, 58 WAY ABS CONNECTOR

INTERFACE SPECIFICATION: 114-94233 58 WAY ABS CONNECTOR

1.3 DELIVERY CONDITION OF CONNECTOR AND WIRE COVER

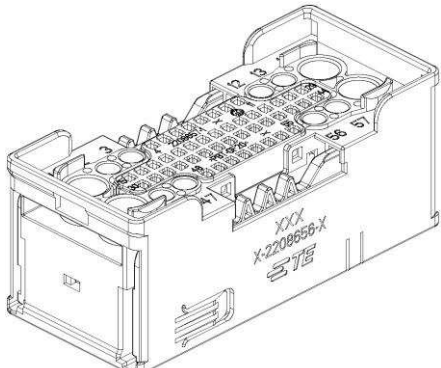
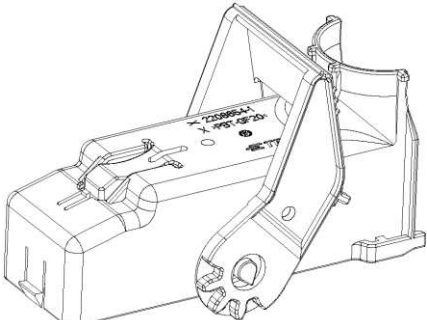
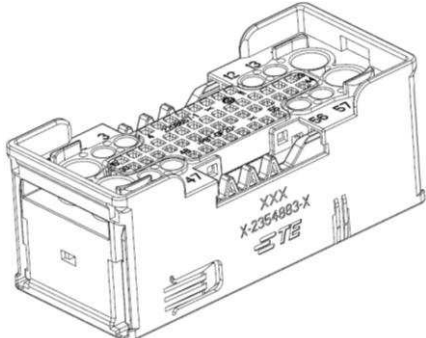
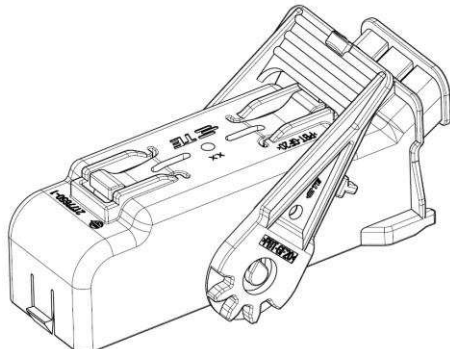
<p>58 WAY ABS CONNECTOR ASSEMBLY</p>	<p>PN X-2208656-X</p>	
<p>WIRE COVER ASSEMBLY, CABLE EXIT 180° 58 WAY ABS CONNECTOR</p>	<p>PN 2208653-1</p>	
<p>FEMALE HOUSING ASSEMBLY, 58 WAY ABS CONNECTOR</p>	<p>PN X-2354883-X</p>	
<p>WIRE COVER, 58 WAY ABS CONNECTOR</p>	<p>PN 2177649-X</p>	

## 1.4 APPLICABLE COMPONENTS

APPLICABLE COMPONENTS BOX						
DESCRIPTION	PLATING /COLOUR	SUPPLIER	SUPPLIER PART NO. (WIRE SIZE)	APPL. SINGLE WIRE SEAL	TE APPL. SPEC. TE PROD. SPEC.	APPL CONTACT CAVITY NUMBER
MCON 1.2 CB UNSEALED FEMALE TERMINAL	TIN	TE	1534594-1 (0.35mm <sup>2</sup> )	NOT APPLICABLE	114-18464 108-18782	4-11, 15-44, 48-55
MCON 1.2 CB UNSEALED FEMALE TERMINAL	TIN	TE	1670144-1 (0.5-0.75mm <sup>2</sup> )	NOT APPLICABLE		
AMP MCP 2.8K SEALED FEMALE TERMINAL	TIN	TE	1241394-1 (0.5-1.0mm <sup>2</sup> )	963294-1 FOR CABLE Ø 1.4-2.1 963293-1 FOR CABLE Ø 2.0-2.7 963292-1 FOR CABLE Ø 2.7-3.0	114-18387 108-18717	2-3, 12-13, 46-47, 56-57
AMP MCP 2.8K SEALED FEMALE TERMINAL	TIN	TE	1241396-1 (1.0-2.5mm <sup>2</sup> )			
AMP MCP 6.3/4.8K SEALED FEMALE TERMINAL	TIN	TE	1241416-1 (~2.5-4.0mm <sup>2</sup> )			
AMP MCP 6.3/4.8K SEALED FEMALE TERMINAL	Ag OVER Ni	TE	1-1241418-3 (~4.0-6.0mm <sup>2</sup> )	1394512-1 FOR CABLE Ø 3.4-3.7 1719043-1 FOR CABLE Ø 4.0-4.5	114-18388 108-18718	1, 14, 45, 58
BLIND PIN FOR MCON 1.2 CB CONTACT CAVITIES	BROWN	TE	1-1452424-1	NOT APPLICABLE	-	4-11, 15-44, 48-55
BLIND PLUG FOR MCP 2.8K CONTACT CAVITIES	NATURAL	TE	828922-1	NOT APPLICABLE	-	2-3, 12-13, 46-47, 56-57
BLIND PLUG FOR MCP 6.3/4.8K CONTACT CAVITIES	TRANSPARENT	TE	967652-1	NOT APPLICABLE	-	1, 14, 45, 58
WIRE COVER	BLACK	TE	2208653-1	NOT APPLICABLE	TBD	NOT APPLICABLE

## 2 CONNECTOR OPERATING INSTRUCTIONS

### 2.1 ASSEMBLY OF THE CONNECTOR

1. FEMALE HOUSING
2. SLIDER RIGHT
3. SLIDER LEFT
4. RETAINER (TPA)
5. PERIPHERAL SEAL
6. MAT SEAL
7. MAT SEAL COVER
8. CAVITY BLOCK
9. CAVITY BLOCK INSERT

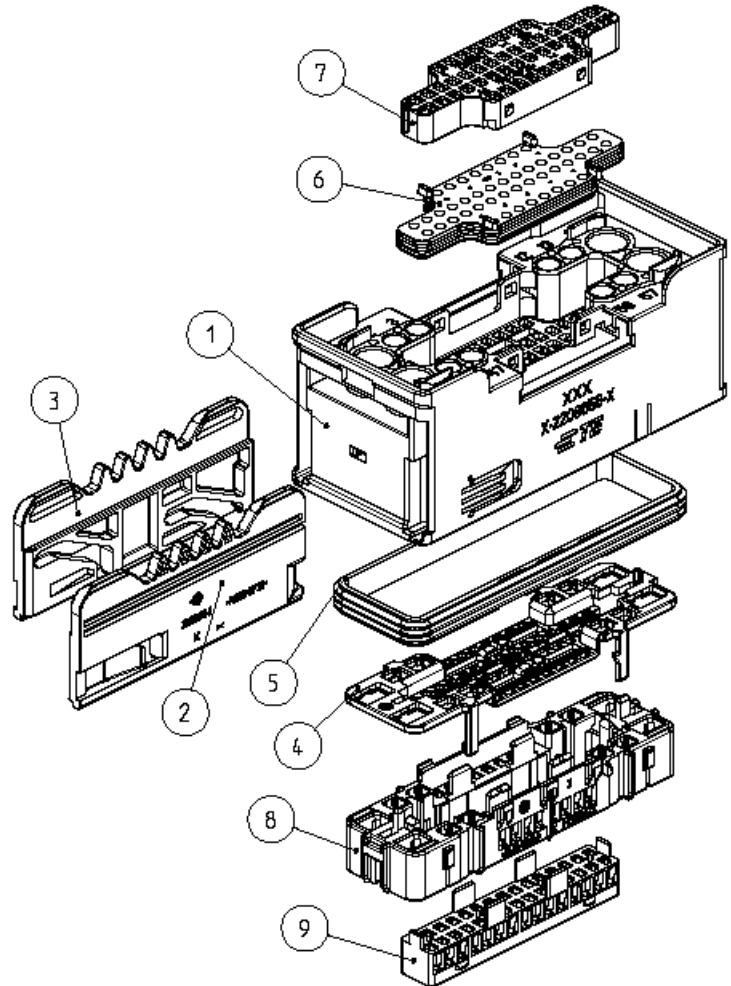

## 2.2 TERMINAL INSERTION / REMOVAL INSTRUCTIONS

### 2.2.1 TERMINAL INSERTION

#### MCON 1.2 CB

INSERT TERMINALS STRAIGHT IN CAVITIES UNTIL “CLICK”.

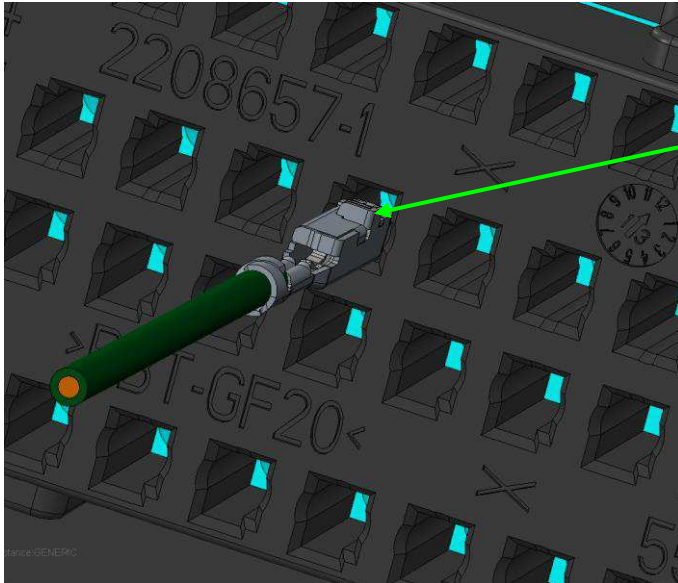

TERMINAL ORIENTATION  
FEATURE

#### AMP MCP 2.8K

INSERT TERMINALS STRAIGHT IN CAVITIES UNTIL “CLICK”.

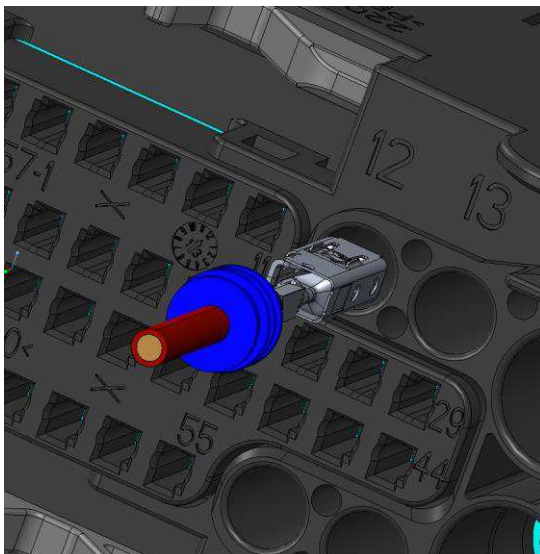

NO TERMINAL  
ORIENTATION FEATURE

NOTE:  
TERMINAL INSERTION TO END-LOCK  
POSITION IS ONLY POSSIBLE WITH  
TERMINAL PARALLEL TO THE HOUSING

AMP MCP 6.3/4.8K

INSERT TERMINALS STRAIGHT IN CAVITIES UNTIL "CLICK".

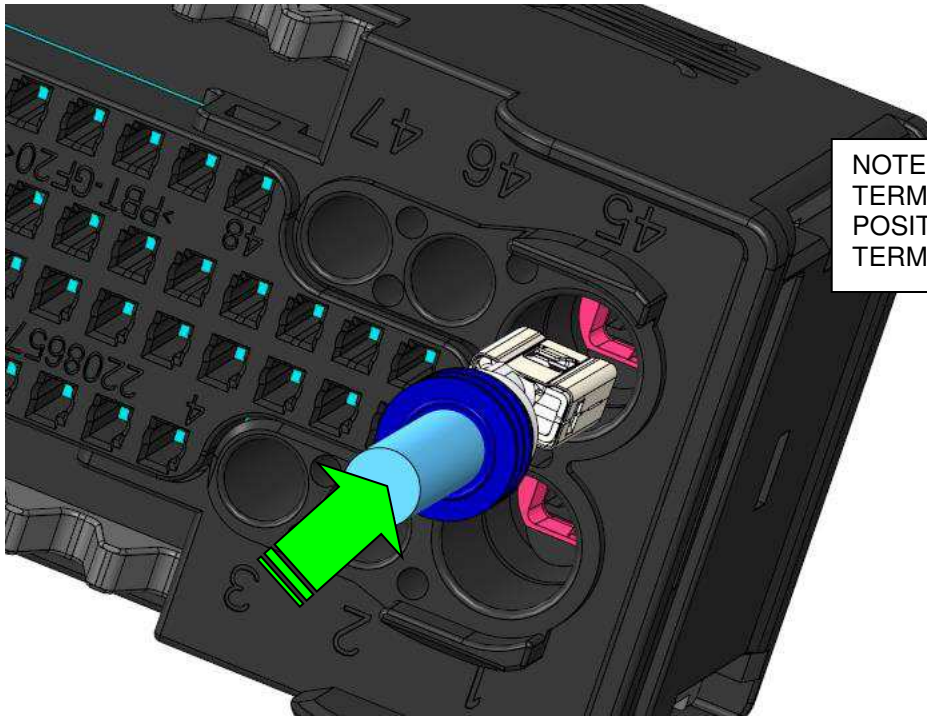

NO TERMINAL  
ORIENTATION  
FEATURE

NOTE:  
TERMINAL INSERTION TO END-LOCK  
POSITION IS ONLY POSSIBLE WITH  
TERMINAL PARALLEL TO THE HOUSING

**NOTE:**

AFTER TERMINAL INSERTION OPERATION THE SPACER (TPA) MUST BE MOVED FROM PRE-LOCK POSITION TO FULLY ENGAGED POSITION.

---

## 2.2.2 RETAINER (TPA) MOVING TO END-LOCK POSITION

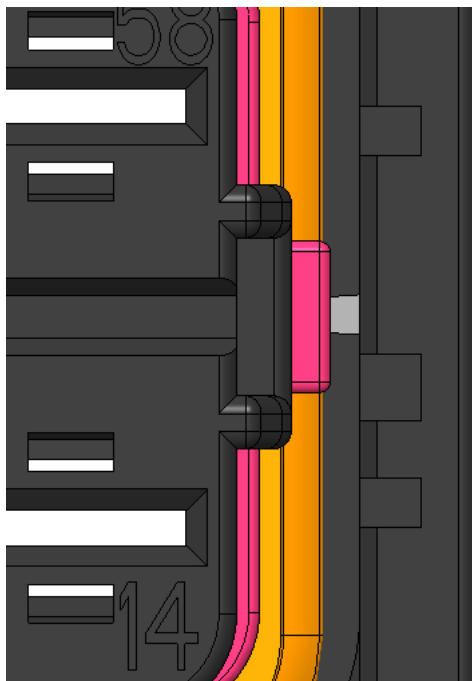

PLACE A SCREWDRIVER OR  
SIMILAR TOOL INTO THE SLOT AS  
SHOWN AND PUSH THE RETAINER  
(TPA) INTO END-LOCK POSITION



---

## 2.2.2 RETAINER (TPA) MOVING TO PRE-LOCK POSITION



PLACE A SCREWDRIVER OR SIMILAR TOOL INTO THE SLOT ON THE OPPOSITE HOUSING WALL AS SHOWN AND PUSH THE RETAINER (TPA) INTO PRE-LOCK POSITION

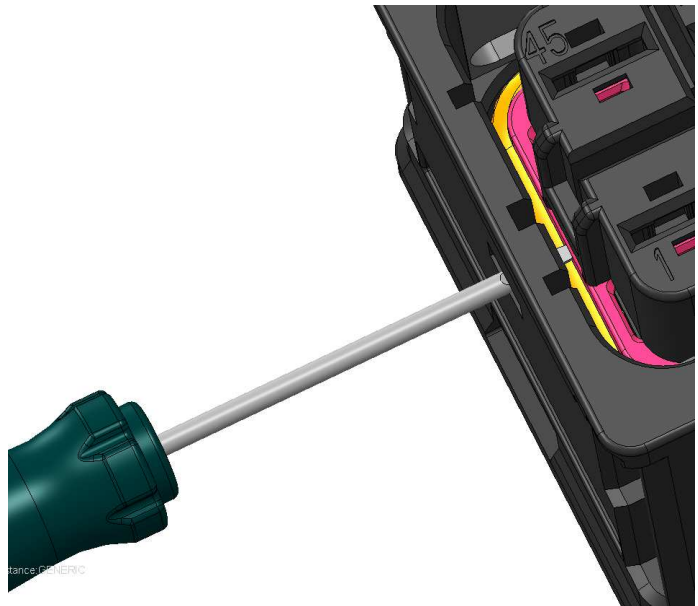

2.2.3 TERMINAL EXTRACTION –MCON 1.2 CB

**NOTE:** RETAINER (TPA) MUST BE BROUGHT INTO PRE-LOCK POSITION BEFORE TERMINAL REMOVAL OPERATIONS!

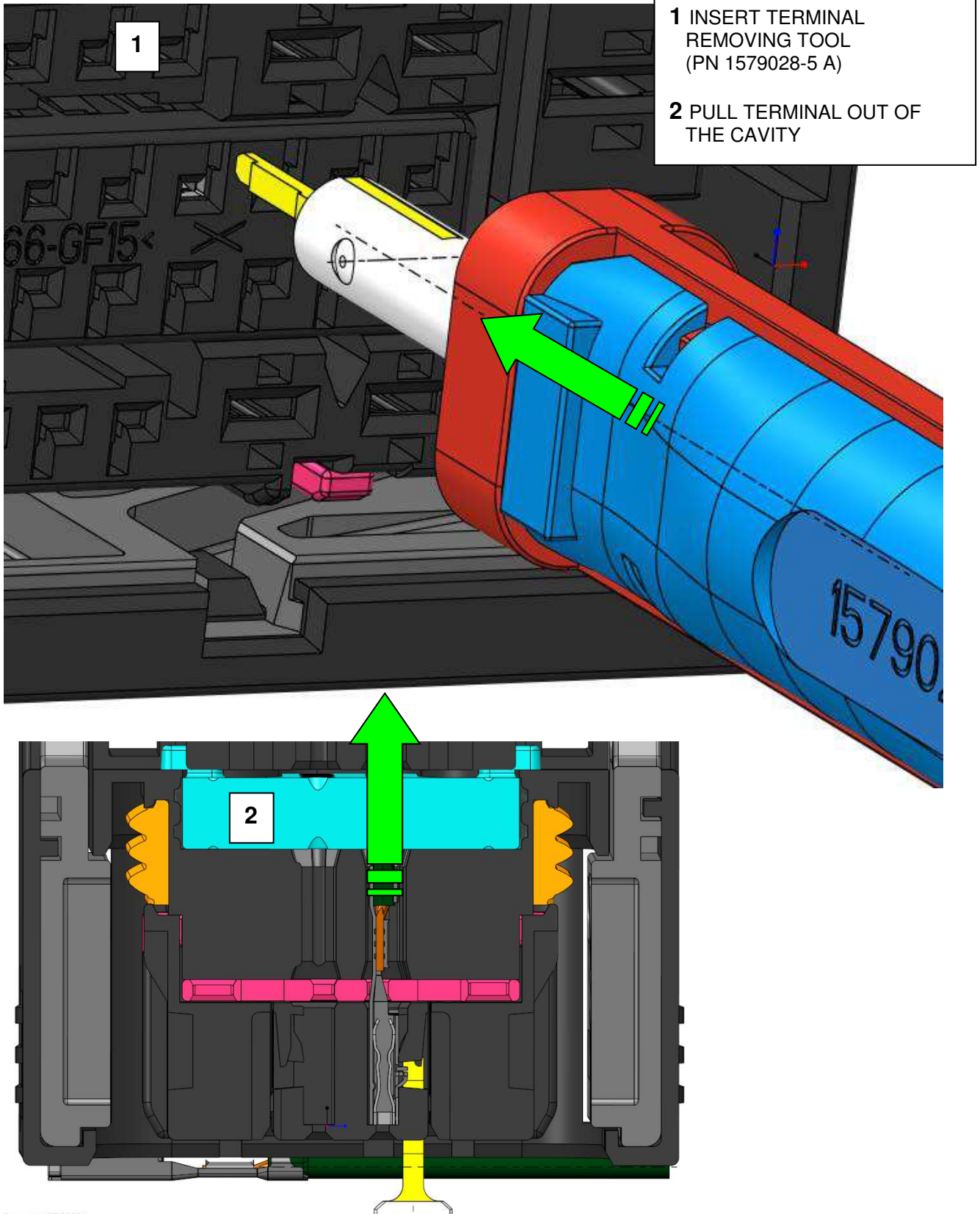

2.2.4 TERMINAL EXTRACTION – MCP 2.8K AND 6.3/4.8K**NOTE:**

RETAINER (TPA) MUST BE BROUGHT INTO PRE-LOCK POSITION BEFORE TERMINAL REMOVAL OPERATIONS!

- 1** INSERT TERMINAL REMOVAL TOOL (PN 1-1579007-6)
- 2** PULL TERMINAL OUT OF THE CAVITY

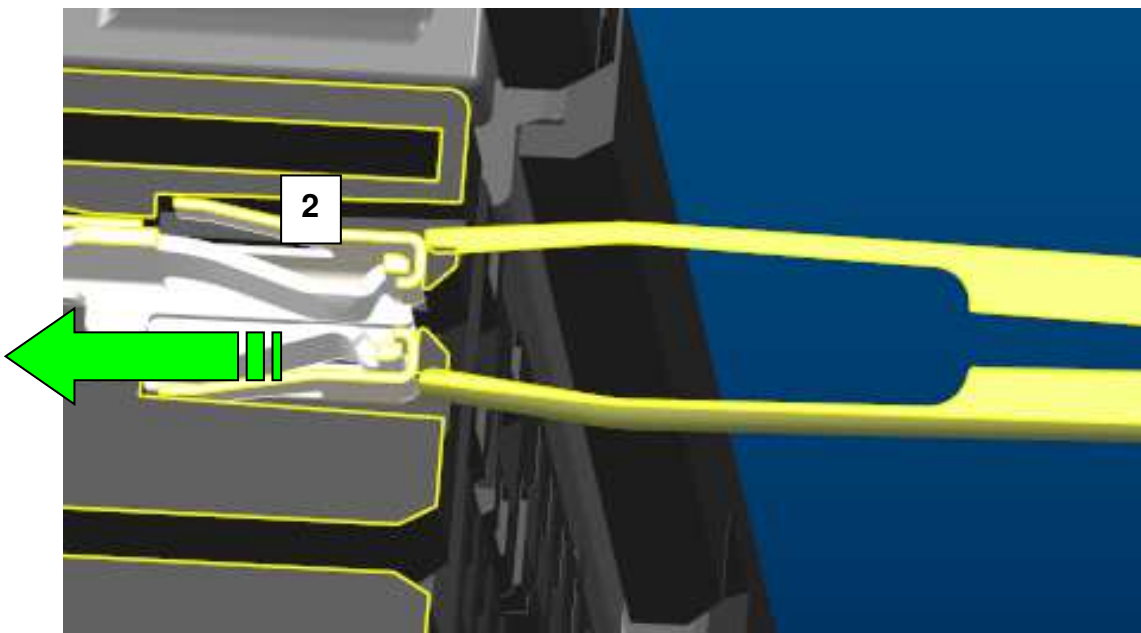
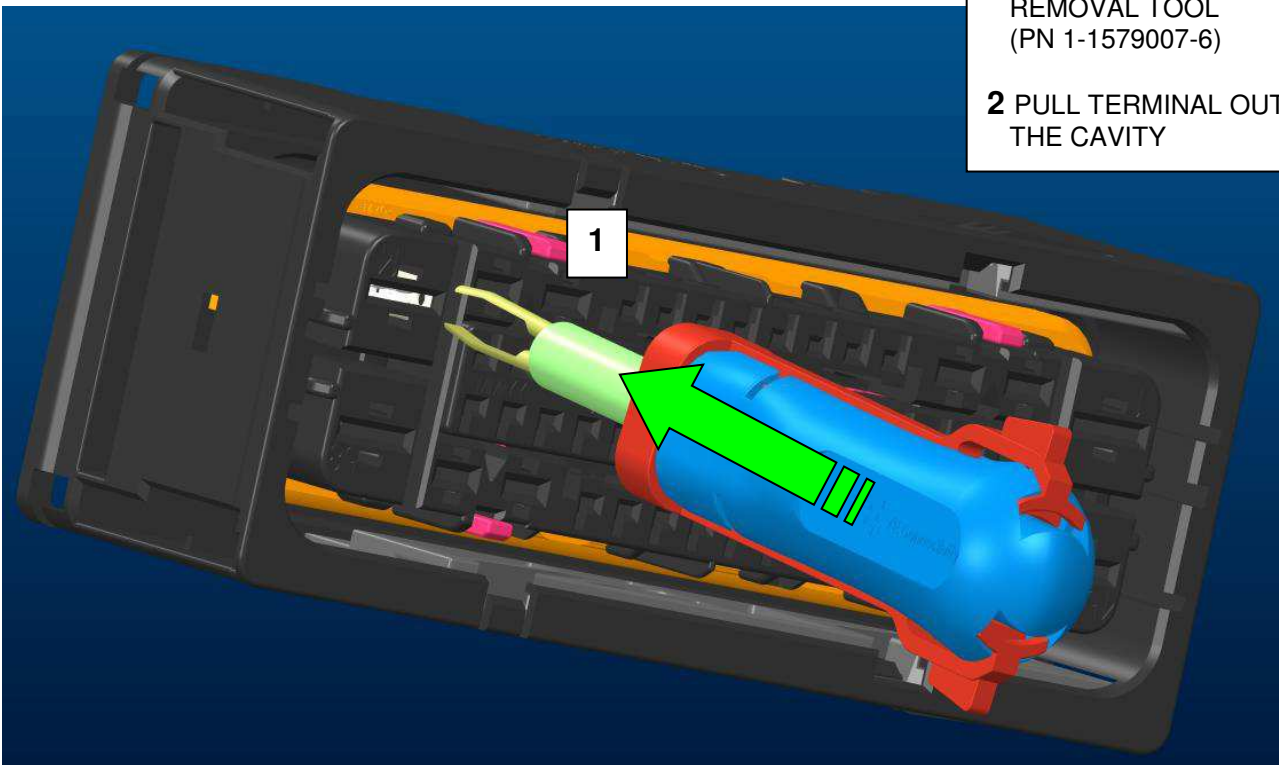

## 2.3 WIRE OUTER DIAMETER REQUIREMENTS FOR SEALING (MAT SEAL)

PLEASE SEE CUSTOMER DRAWING

## 2.4 COVER MOUNTING / REMOVAL INSTRUCTIONS FOR CABLE EXIT 180°/90°

### 2.4.1 COVER MOUNTING

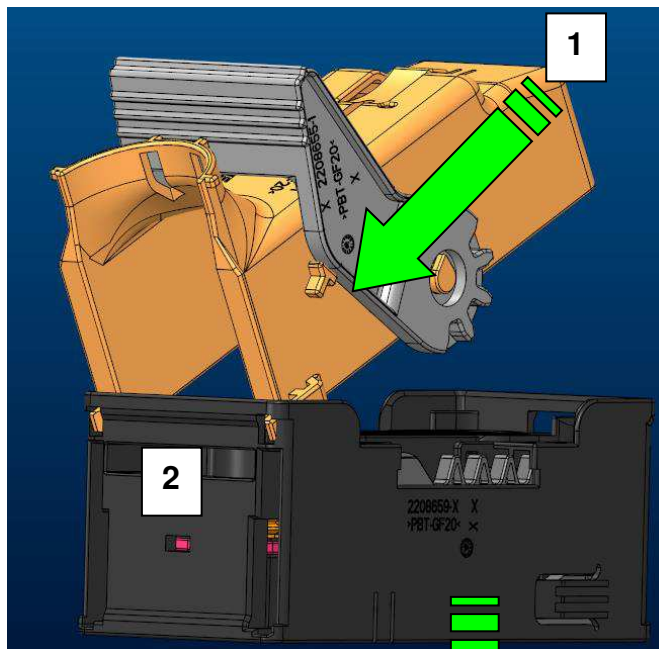

**1** POSITION COVER LIKE SHOWN IN THE PICTURE

**2** INSERT HOOKS INTO THE TWO GAPS

**3** PRESS DOWN THE COVER UNTIL THE LATCH SNAPS INTO THE WINDOW

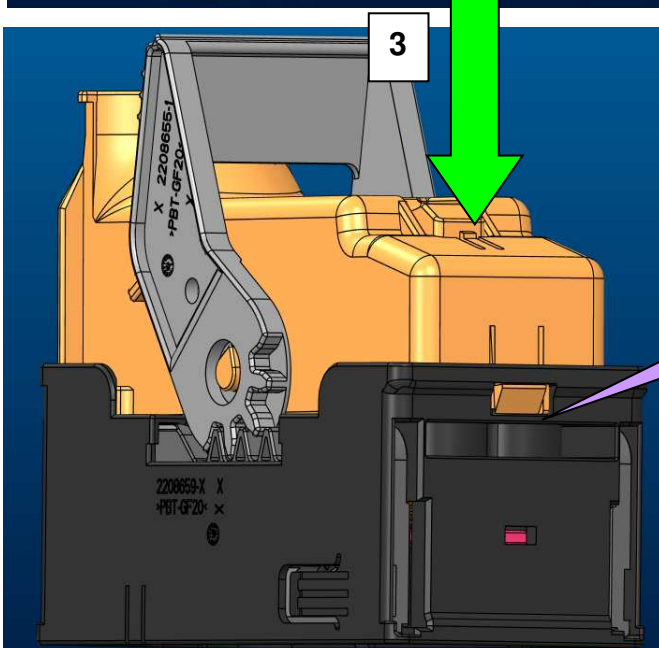

**CLICK!**



2.4.2 COVER REMOVAL

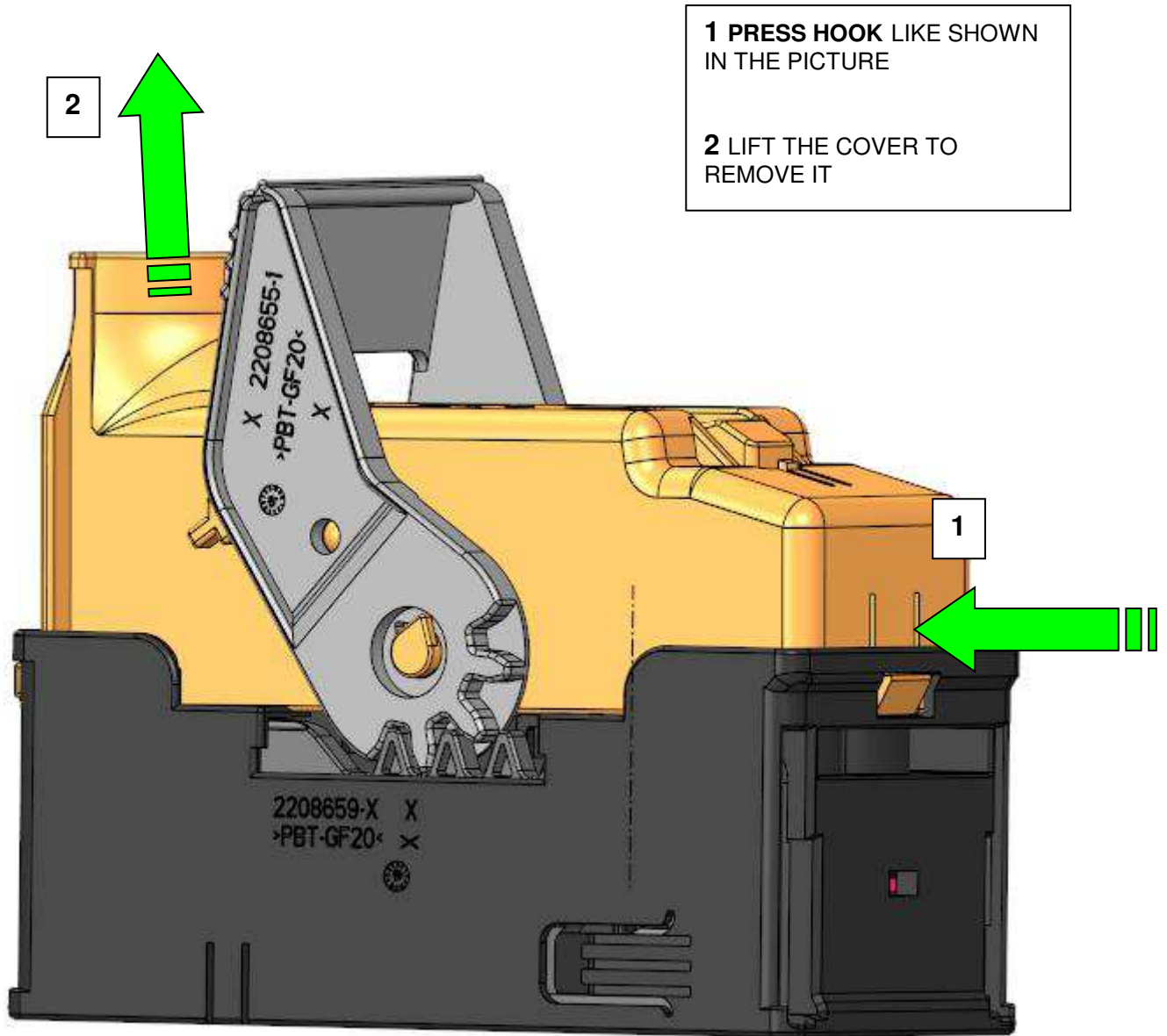

---

### 3 CONNECTOR MATING / UNMATING OPERATIONS

#### 3.1 CONNECTOR MATING

**NOTE:** BEFORE MATING THE CONNECTOR MAKE SURE THAT THE LEVER IS AT PRE-LOCK POSITION

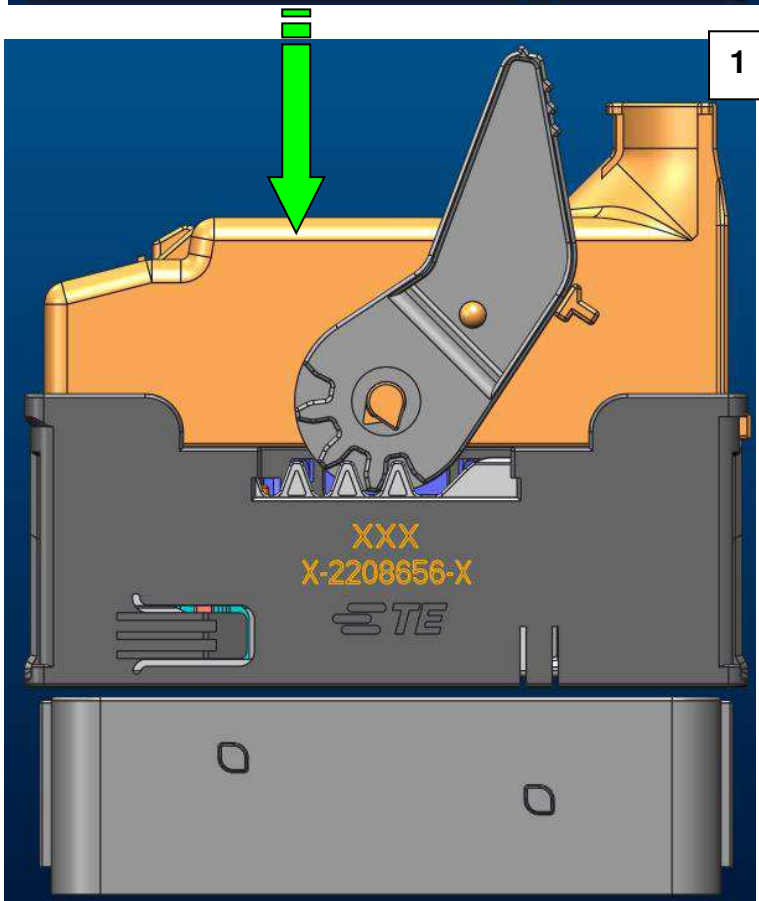
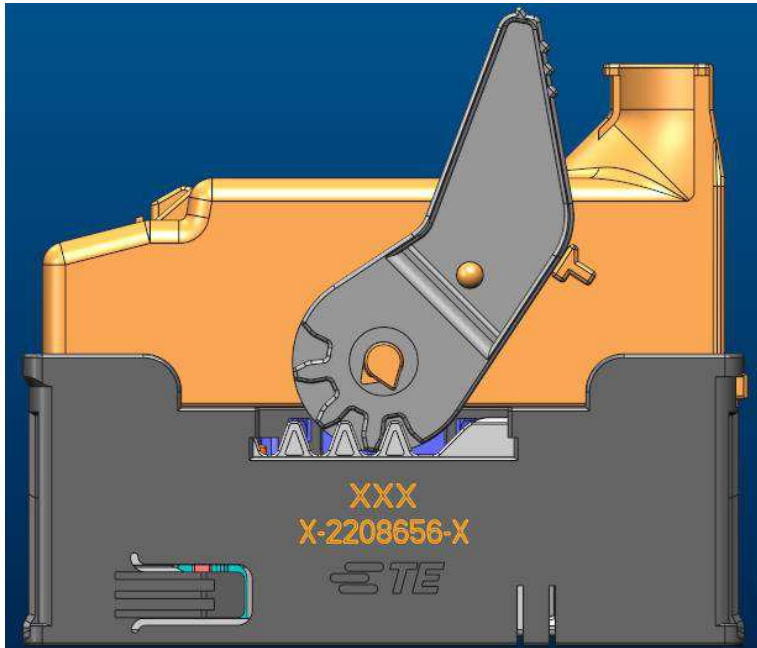

1. MATE FEMALE CONNECTOR AND INTERFACE UNTIL THE FORCE INCREASES SUBSTANTIALLY
2. TURN THE LEVER AROUND UNTIL "CLICK"

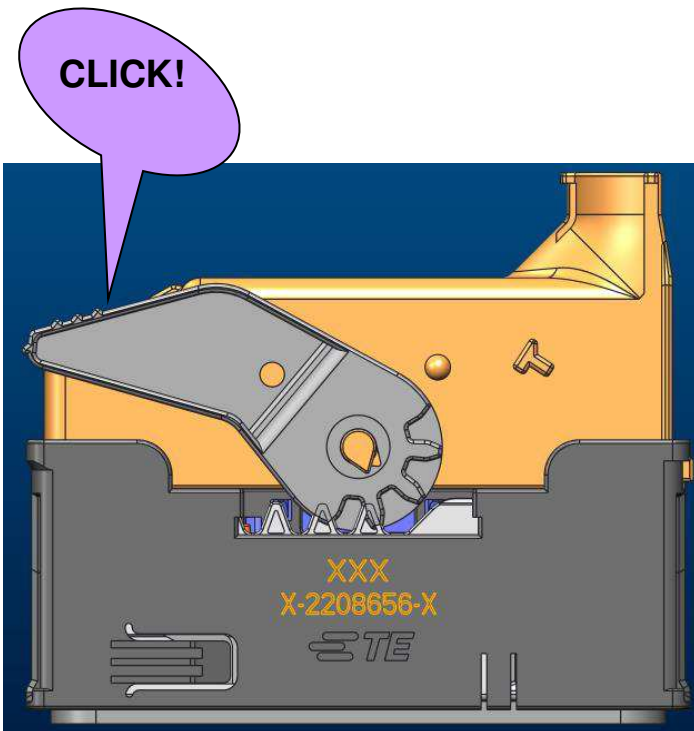
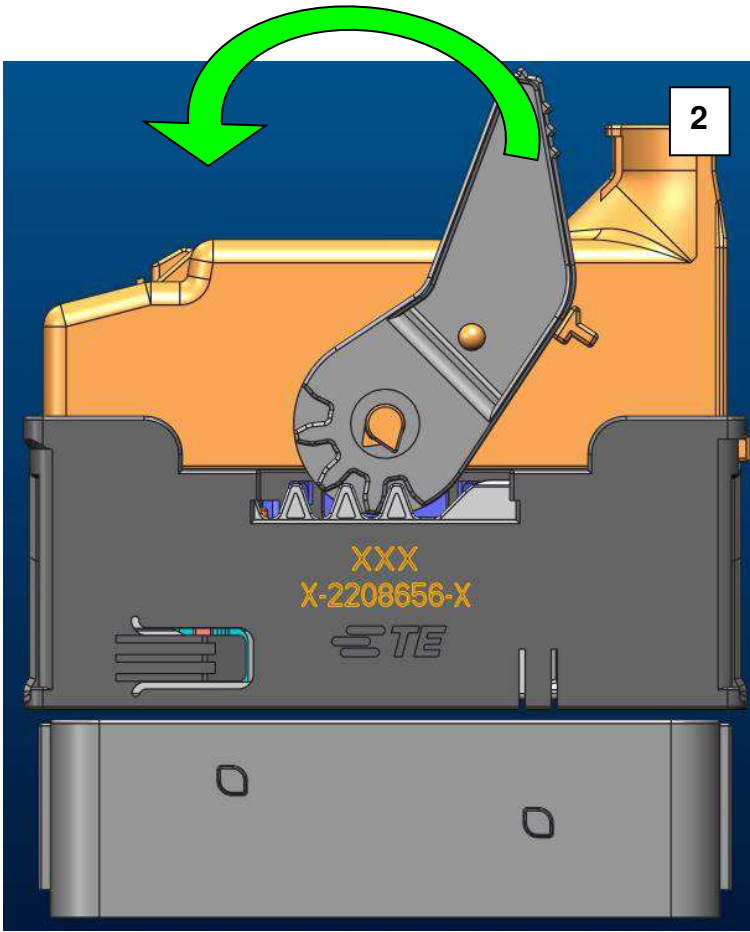

## 3.2 CONNECTOR UNMATING

1

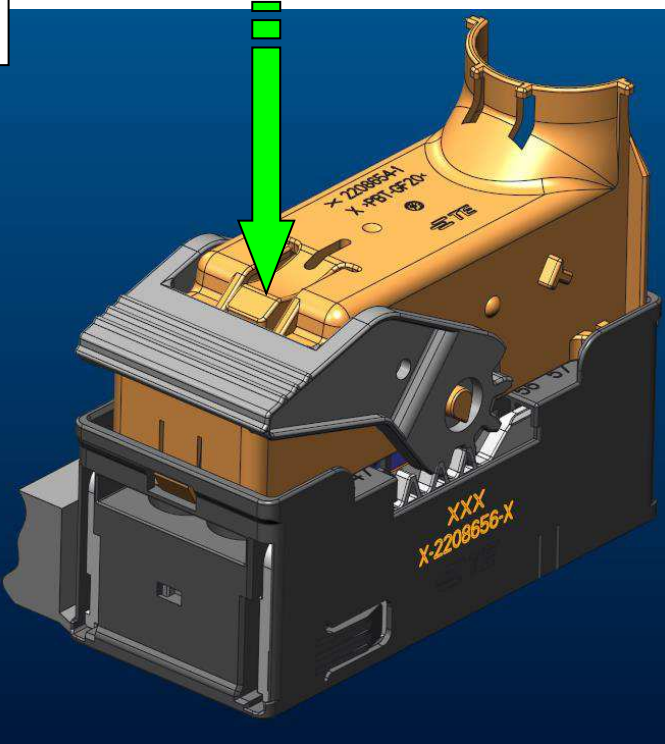

1. PUSH DOWN THE LEVER LOCKING LATCH UNTIL THE LEVER IS RELEASED.
2. TURN THE LEVER AROUND TO ITS "PRE-LOCK" POSITION

2

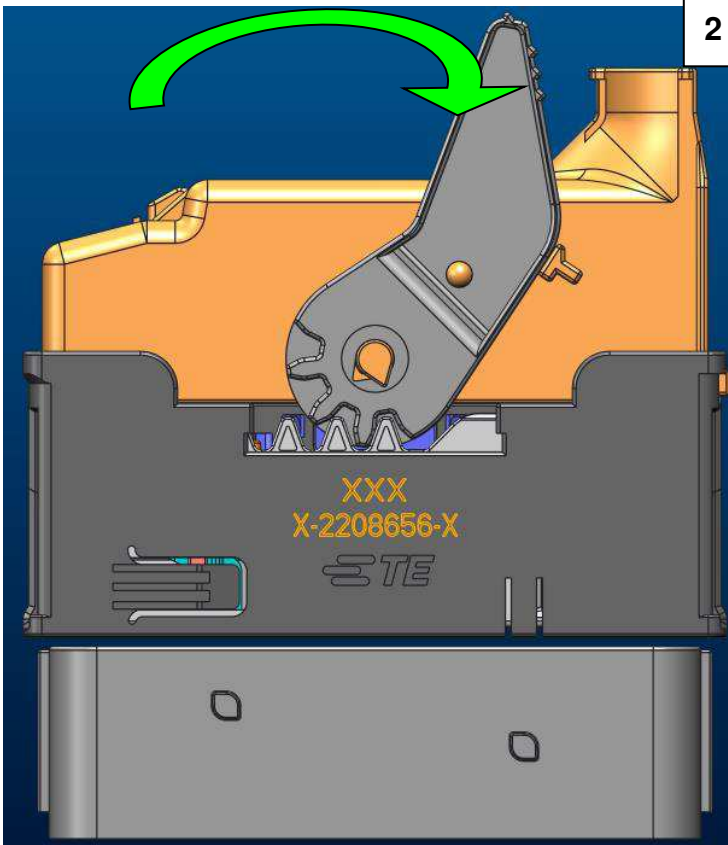



- 
- 4 PRECONISATION DE STOCKAGE, DE MANIPULATION ET DE RECONDITIONNEMENT  
*RECOMMENDATIONS FOR STORAGE, HANDLING AND REPACKAGING*
- A. Stocker dans des lieux bien aérés où la température et l'humidité relative restent dans les limites suivantes : +5° à +50°C ; 30% à 75% HR  
*Store in a well ventilated environment with the following relative temperature and humidity range: +5° to +50°C ; 30% to 75% HR.*
  - B. Stocker sans contact avec le sol, sur palette ou plate-forme, sur surface sèche et propre jusqu'à ce que les emballages soient récupérés pour mise en production.  
*Store above the ground, on a pallet or platform, a clean dry surface until the packages are retrieved for production.*
  - C. Stocker les emballages à l'abri des précipitations d'eau et de l'influence directe des UV.  
*Store packages away from water and direct UV rays.*
  - D. Stocker les emballages à l'abri des sources de chaleur et des zones subissant des fortes variations de températures.  
*Store packages away from heat and areas with high temperature variations.*
  - E. Stocker à l'abri des variations rapides de température ou d'hygrométrie pour éviter la condensation à l'intérieur des emballages.  
*Keep away from high temperature or hygrometry variations to avoid condensation inside the packages.*
  - F. Stocker les emballages à l'abri de la poussière pour maintenir les composants propres.  
*Store packages away from dust to keep the components clean.*
  - G. Conserver les emballages dans l'état de réception, sans défaire le ruban adhésif jusqu'à utilisation.  
*Keep packages as they are delivered, without undoing the adhesive ribbon until use.*
  - H. Reconditionner les emballages après prélèvement partiel dans ceux-ci.  
*Wrap up packages after partial sampling.*
  - I. Ne pas marcher et ne pas poser d'objets lourds sur les emballages.  
*Do not walk or place heavy objects on packages.*
  - J. Les emballages reçus, doivent être traités sur la base du first-in, first-out (FIFO).  
*Packages received should be treated on the basis of first-in, first out (FIFO).*
  - K. Lorsque les emballages sont stockés en racks, placer les cartons les plus lourds en dessous, les plus légers sur le dessus afin de ne pas abimer les pièces.  
*Where packages are stored in racks, place the heavier cartons below and the lighter ones above not to damage the parts.*
  - L. Une période (≈24 heures) d'équilibrage thermique est nécessaire avant câblage des connecteurs.  
*A 24 hour thermal balancing period is needed before wiring connectors.*

---

## 5 TEST DE CONFORMITE ELECTRIQUE / *ELECTRICAL TEST CONTROL*

### DEFINITION DES DEFAUTS POTENTIELS / *DEFINING POTENTIAL FAULTS*

- A. Mauvais adressage du contact dans le boîtier / *Poorly addressed contact in the housing*  
Le contact est correctement inséré et encliqueté mais pas dans la bonne alvéole.  
*The contact is correctly inserted and locked but not in the right cavity.*
- B. Erreur d'association / *Association Error*  
Tentative d'insertion d'un clip dans un boîtier porte-languettes, ou inversement.  
*Tentative insertion of a receptacle in the Tab housing, or vice versa*
- C. Absence d'encliquetage / *No locking*  
Le contact n'est pas verrouillé dans le boîtier.  
*The contact is NOT locked in the housing.*
- D. Mauvaise orientation du contact / *Poor orientation of the contact*  
L'orientation du contact est à 90° autour de l'axe longitudinal d'insertion du contact.  
*The contact is oriented at 90° around the insertion longitudinal axis of the contact.*
- E. Défauts de verrou secondaire / *Faults with the secondary locking device*  
Le Double Verrouillage n'est pas correctement fermé.  
*The secondary locking device is not properly closed*

### CONTROLE ET MOYENS PRECONISES

#### Adressage / *Addressing*

Contrôle = continuité électrique

*Test = electricity continuity*

- F. Erreur d'association / *Association error*  
Détection visuelle évidente - Détection par contrôle électrique  
*Obvious visual detection - Detection by electrical test*
- G. Encliquetage / *Terminals locking*  
Si un ou plusieurs contacts sont mal insérés, la fermeture du Double Verrouillage est impossible avec un effort inférieur à 30N.  
Si le Double Verrouillage est actionné mais un des contacts mal inséré (clip ou languette reculé par rapport à la position encliquetée), la contrepartie de test électrique détectera l'absence de contact électrique.  
Si un contact a été inséré après l'activation du Double Verrouillage, la contrepartie de test doit pouvoir détecter l'absence de contact électrique.  
*If one or more contacts are not well inserted, the secondary locking device cannot be closed with stress of less than 30N.*  
*If the secondary locking device is activated but the contacts are not well inserted (retracted receptacle or tab from the locked position), the electrical test will detect the absence of an electrical contact.*  
*If a contact was inserted after the activation of the secondary locking device, the electrical test must be able to detect the absence of an electrical contact.*
- H. Orientation / *Orientation*  
L'orientation à 90° est impossible, le cas échéant, impossibilité de fermer le Double Verrouillage.  
*A 90° orientation is not possible, in this case; it is impossible to close the secondary locking device*
- I. Double Verrouillage / *Secondary locking device*
  - Fermeture automatique (recommandée) / ***Automatic Lock (preferred)***:  
Détection au niveau de la course et de l'effort.  
*Detection at the level of stroke and stress.*
  - Fermeture manuelle / ***Manual closing*** :  
Il est possible de contrôler l'encliquetage, lors du contrôle électrique. Si le double verrouillage n'est pas actionné, il sera impossible de brider le connecteur sur le dispositif de test électrique  
*It is possible to check locking during electrical testing. If the secondary locking device is not activated, the connector on the electrical test device cannot be clamped*

SPECIFICATION DE CONTROLE ELECTRIQUE  
 ELECTRICAL TESTING SPECIFICATION

ZONES D'APPUI (BRIDAGE) LORS DU TEST ELECTRIQUE  
 SUPPORT AREAS (CLAMPING) DURING ELECTRICAL TEST

Porte-Clips / Receptacle housing

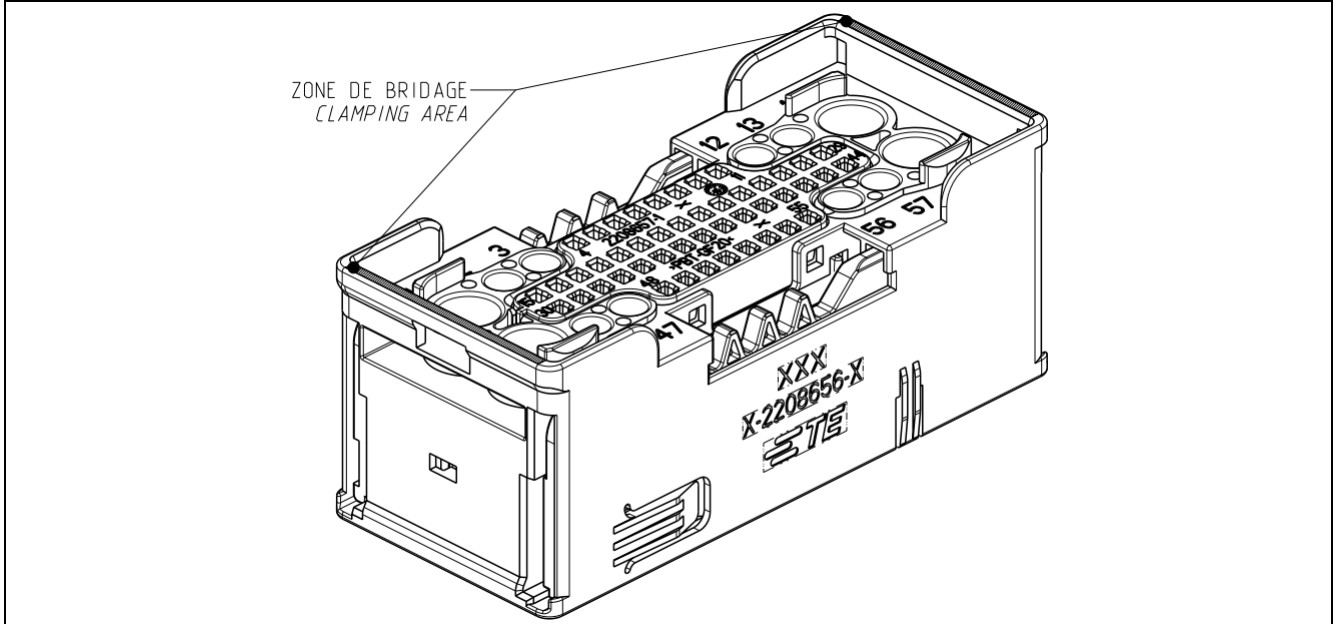

Porte-Clips avec zones de bridage à l'arrière / Receptacle housing with clamping area at the back

DETECTION DE LA FERMETURE DU DOUBLE VERROUILLAGE  
 DETECTING THE CLOSING OF THE SECONDARY LOCKING DEVICE

Porte-Clips / Receptacle housing

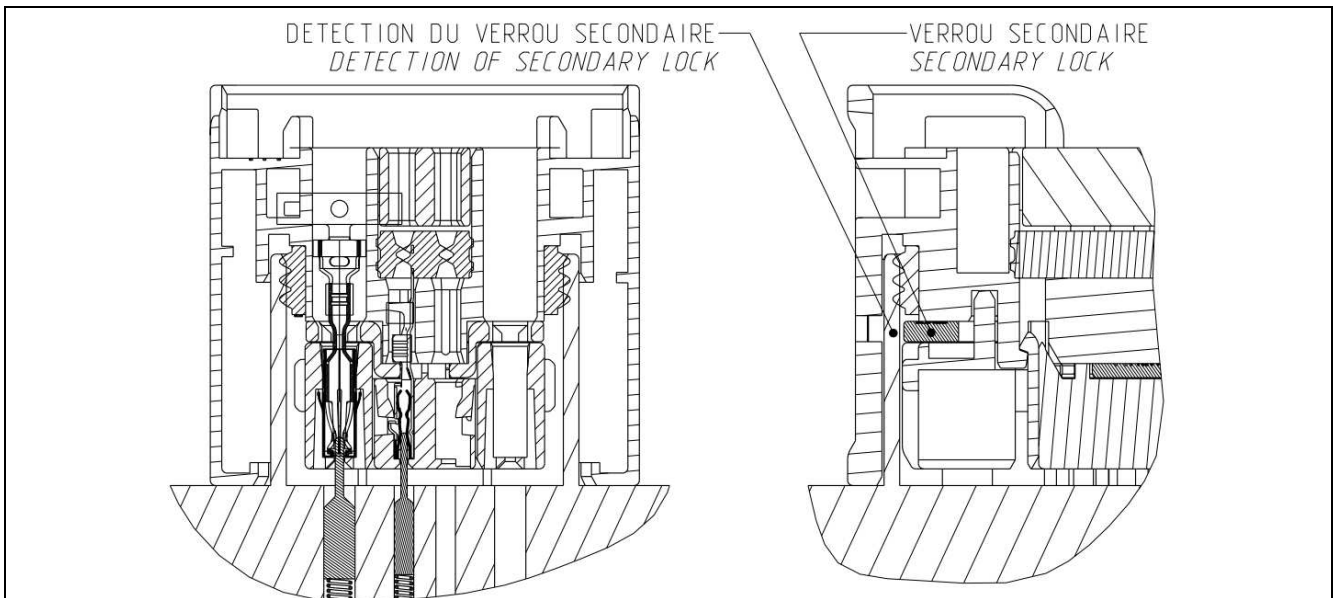

Porte-Clips avec DV correctement fermé  
 Receptacle housing with properly closed secondary locking device

## DEFINITION DES POINTES DE TEST / DEFINITION OF ELECTRICAL TEST POINTS

## CONTROLE ELECTRIQUE SIMPLE / SIMPLE ELECTRICAL CHECKS

## Porte-Clips / Receptacle housing

## Schéma d'implantation / Layout

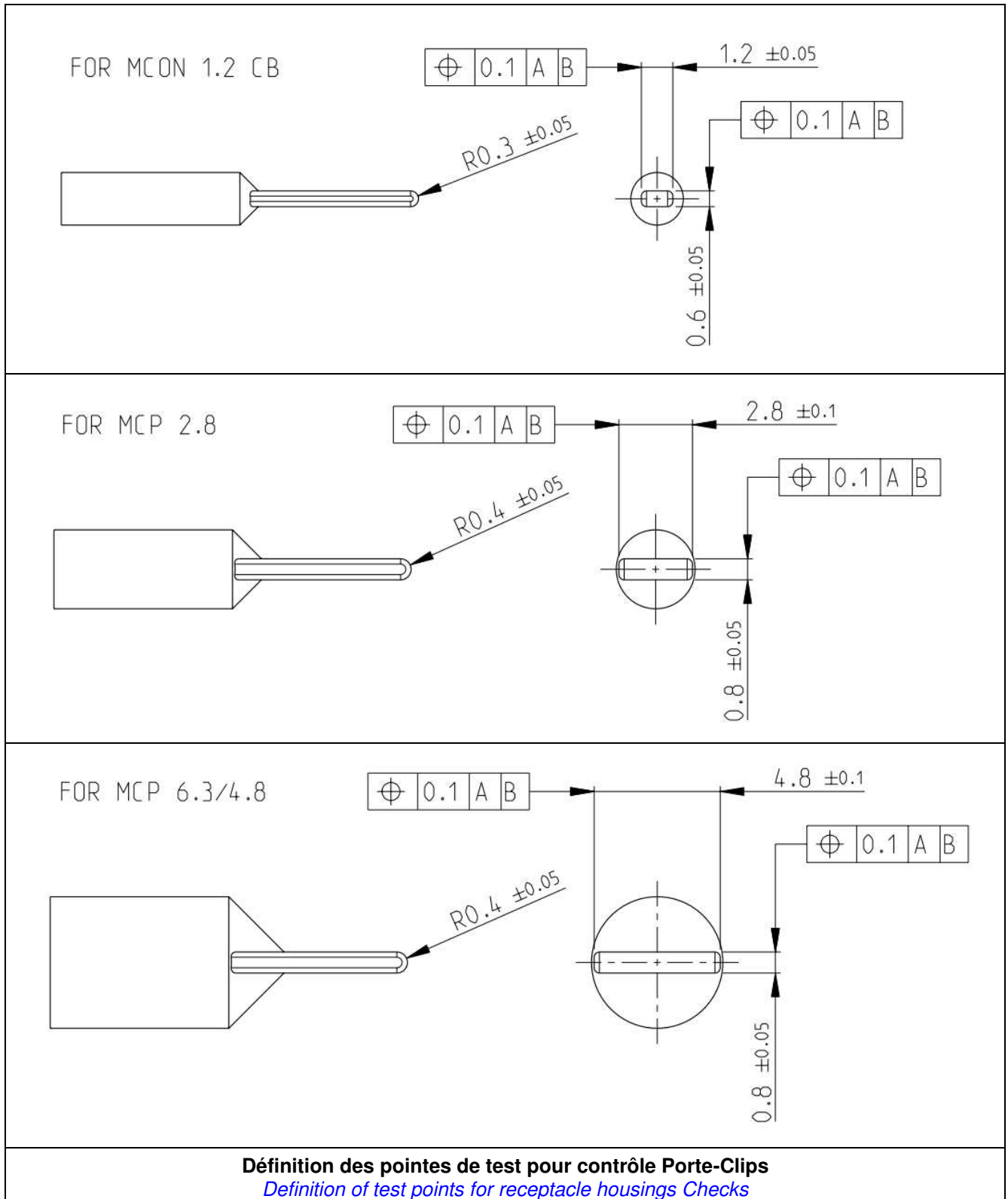

**Course et tarage de la pointe de test*****Stroke and calibration of test point***

- Les touches de contrôle doivent avoir une course maxi de X mm par rapport à la face avant du module alvéole du porte-clips  
*The control buttons should have a maxi stroke of X mm compared with the front face of the cavity holder of the receptacle housing*  
MCON 1.2 CB = 4mm maximum  
MCP 2.8 = 3.75mm maximum  
MCP 6.3/4.8= 3.5mm maximum
- Effort Maxi sur le clip :  $1.25 \pm 0.25N$   
*Maximum stress on the terminal :  $1.25 \pm 0.25N$*

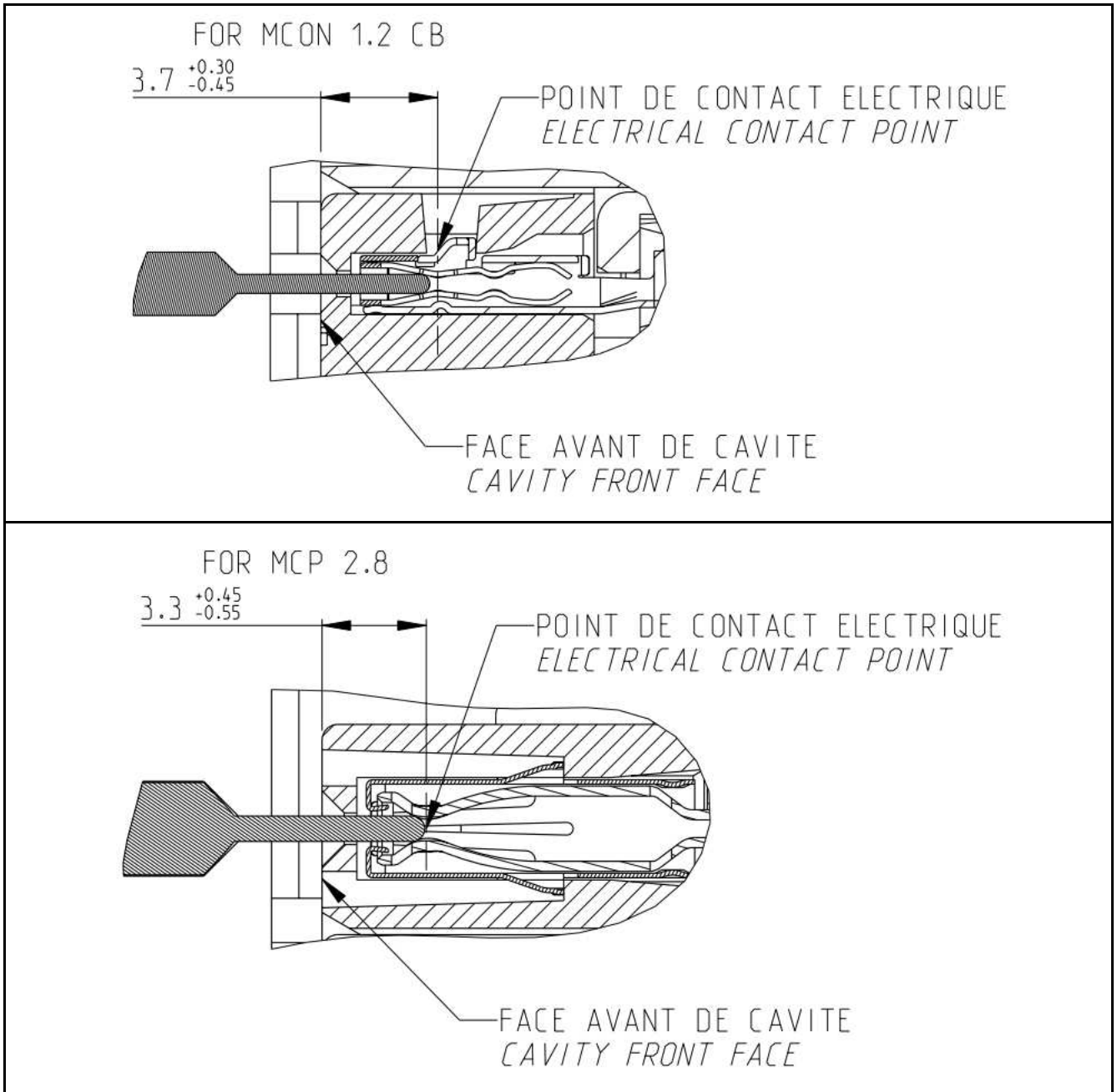

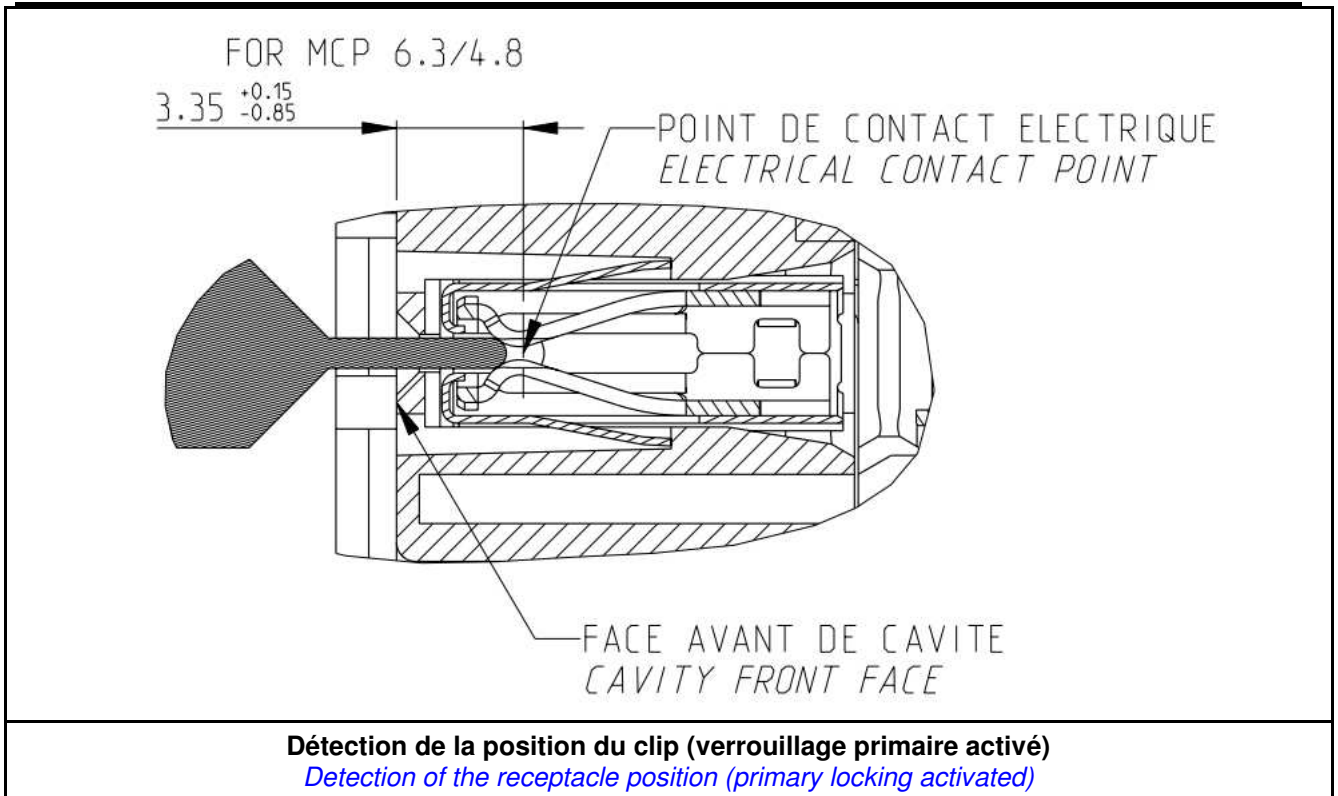

## 6 ACCESSOIRES / ACCESSORIES

### BLIND PLUG FOR MCP 2.8 AND 6.3/4.8 CAVITY:

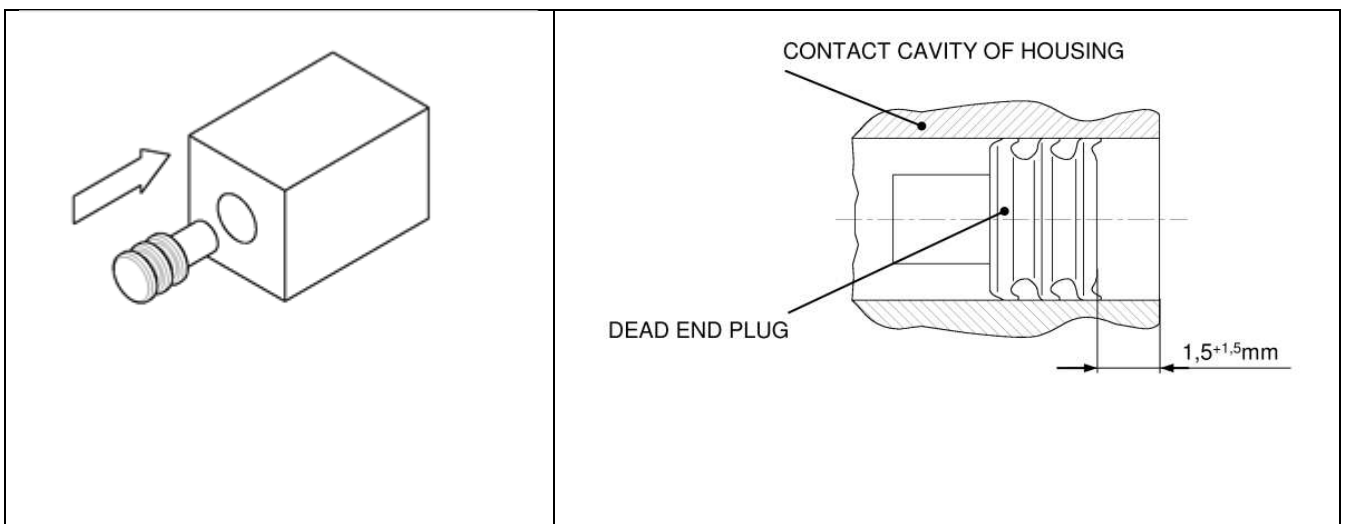

### TAPING:

When taping the wires, do not start or finish near the housing, but leave a free distance of 40 mm minimum with the exit of the cover.

### CABLE TIE:

WIDTH = 4mm maximum  
THICKNESS = 1.2mm maximum



PUT THE HEAD OF CABLE TIE ON LATERAL SIDE OF THE COVER.  
DO NOT PUT THE HEAD OF CABLE TIE ON THE TOP OF COVER, TO AVOID ANY MECHANICAL INTERFERENCE.

THE MAXIMAL DIAMETER FOR THE BUNDLE IS  $\varnothing 27\text{mm}$

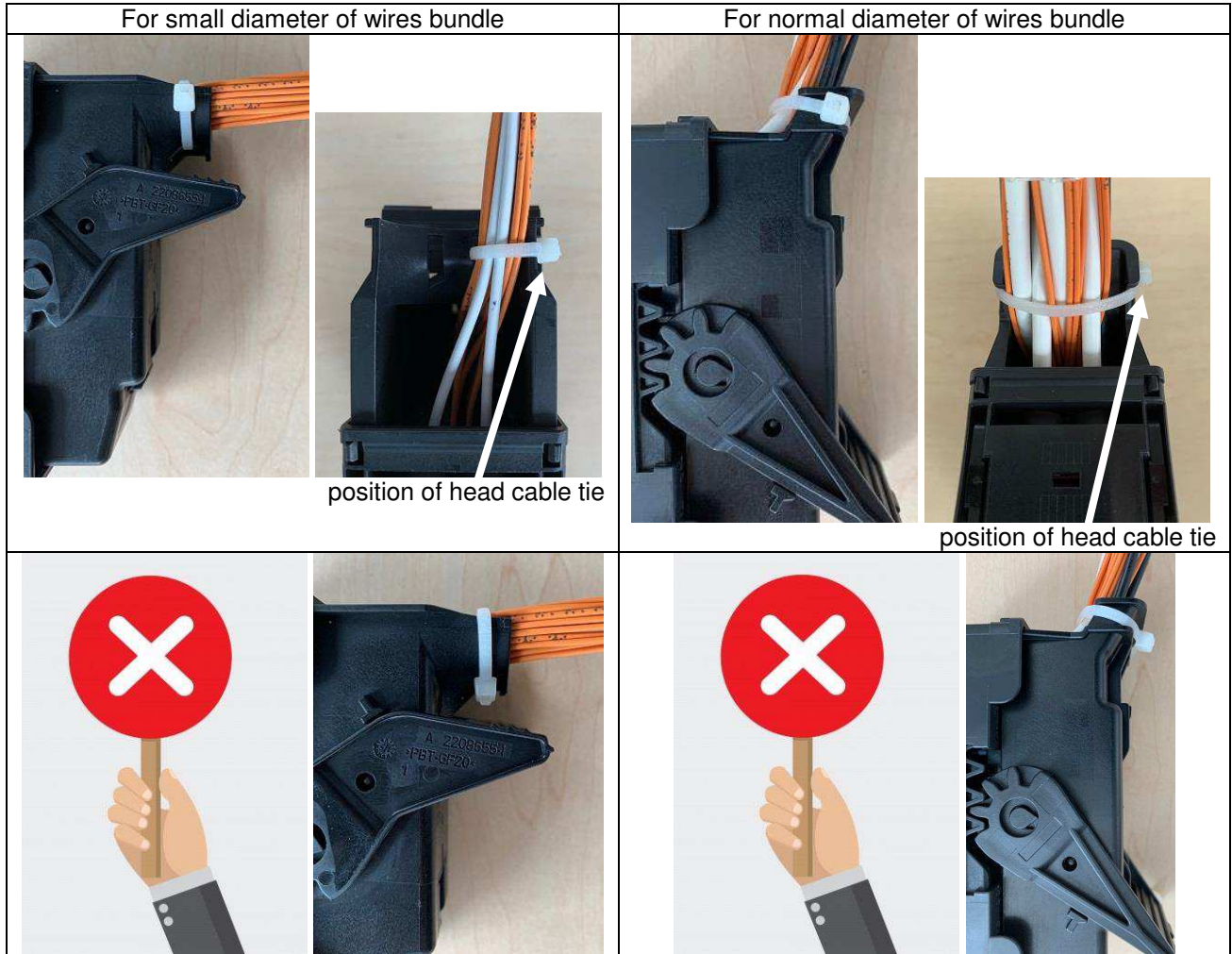

## 7 DEFINITION DES OUTILS / *HAND TOOLS DESIGN*

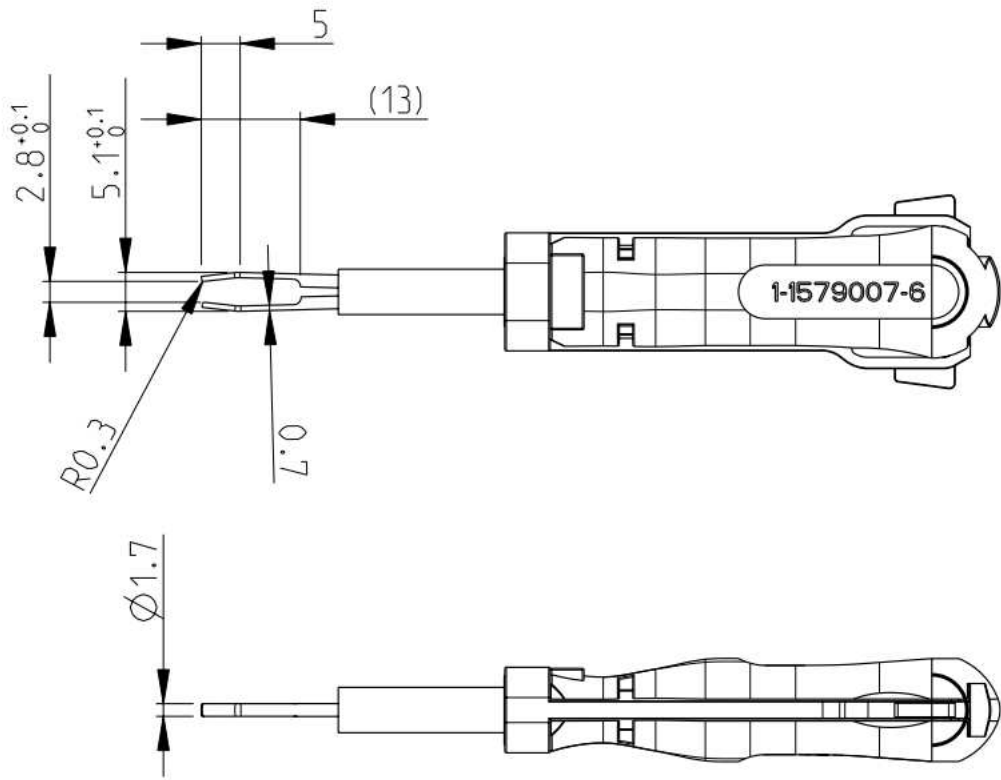

FOR MCP 2.8 AND 6.3/4.8 TERMINAL EXTRACTION TOOL  
 Unspecified tolerance =  $\pm 0.03\text{mm}$

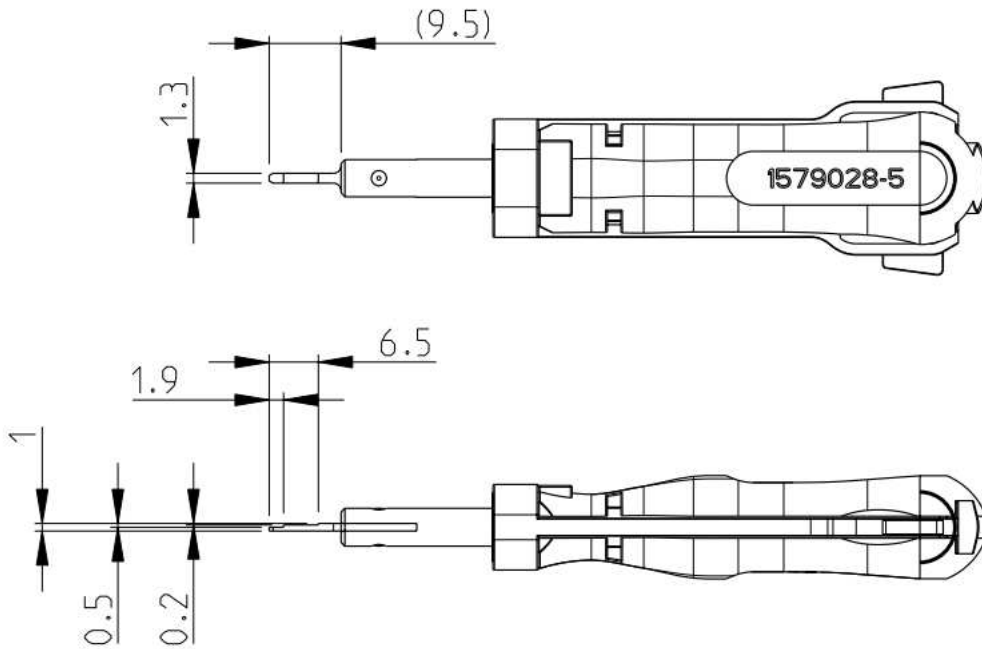

FOR MCON 1.2 CB TERMINAL EXTRACTION TOOL  
 Unspecified tolerance =  $\pm 0.03\text{mm}$



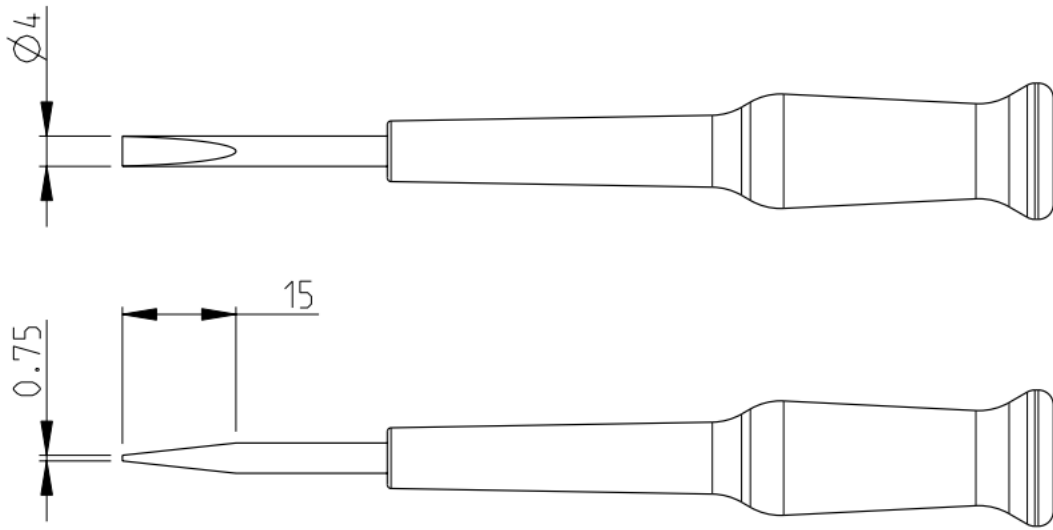

FOR TPA MOVING  
Unspecified tolerance =  $\pm 0.03\text{mm}$