

**Class 1**

---

# VEHICLE CHARGE INLET CCS1 acc. IEC62196-3 / SAE J1772

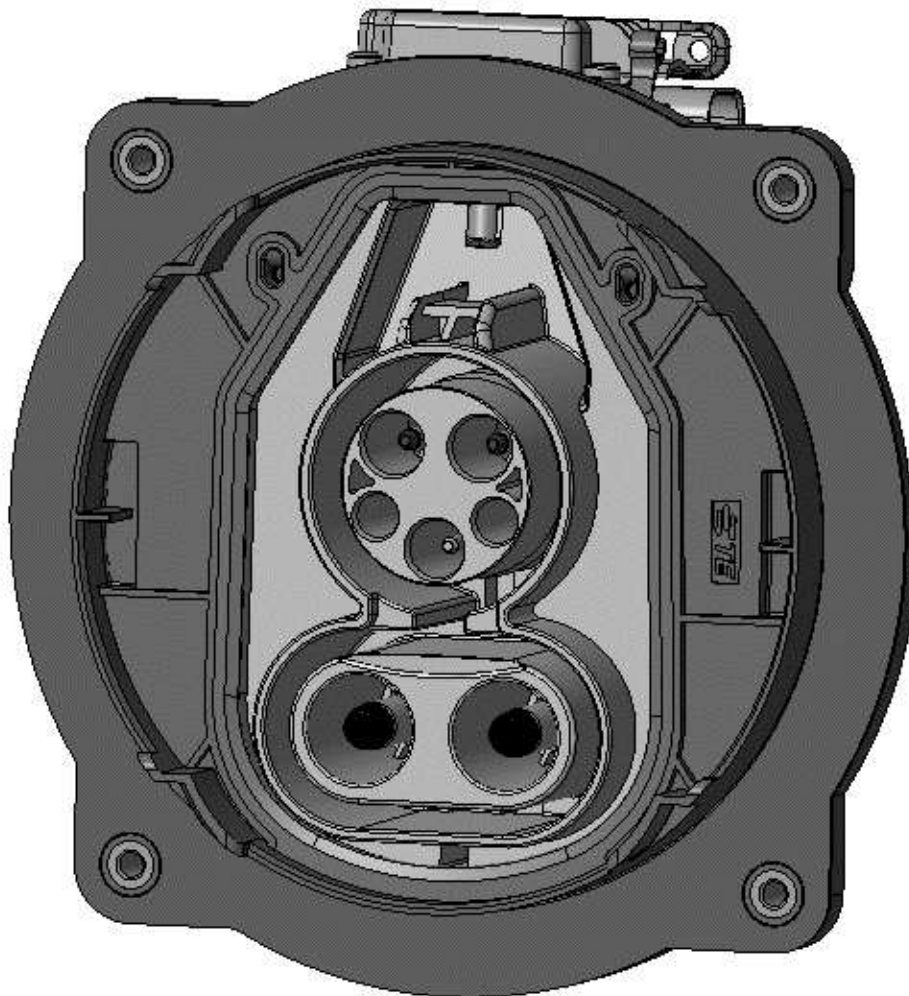

## Content

<b>1.</b>	<b>SCOPE</b> .....	<b>3</b>
1.1.	Content.....	3
1.2.	Processing Note.....	3
<b>2.</b>	<b>APPLICABLE DOCUMENTS</b> .....	<b>4</b>
2.1.	TE Connectivity Documents.....	4
<b>3.</b>	<b>WIRES</b> .....	<b>5</b>
3.1.	Assessment of the wires.....	5
3.2.	Wire selection.....	5
3.3.	Wire preparation.....	5
3.4.	General Specifications of Prescribed Cables.....	5
<b>4.</b>	<b>APPLICATION TOOLS</b> .....	<b>6</b>
<b>5.</b>	<b>Requirements on the crimped contact</b> .....	<b>7</b>
5.1.	Terms of pin contact.....	7
5.2.	Conductor position.....	7
5.3.	Crimp data for the wire crimp.....	7
5.4.	Crimpposition.....	8
5.5.	Cross sections.....	10
5.6.	Contact area.....	10
5.7.	Sealing area.....	10
5.8.	Shape and position tolerances.....	10
5.9.	Measuring equipment and measuring position.....	11
<b>6.</b>	<b>ASSEMBLY INSTRUCTIONS</b> .....	<b>12</b>
6.1.	Assembly overview.....	12
6.2.	Assembly configuration cable exit.....	13
6.3.	Parts to order.....	13
6.4.	Security Advice.....	14
6.5.	Assembly Steps.....	15
6.6.	End of Line Test.....	34
6.7.	Technical Cleanliness Charge Inlet Assembled.....	34

## 1. SCOPE

### 1.1. Content

This specification describes the handling and assembly of the vehicle charge inlets CCS I acc. IEC 62196-3 for conductive charging of electric vehicles. This specification applies to manual assembly of the components from series production tooling, for the standard version.

### 1.2. Processing Note

The processor is responsible for ensuring the quality of the manufacturing process and the proper function of the system. The warranty and liability is excluded if quality deficiency or damages occur by failing compliance to this specification or using not specified, not released tools, cables and components.

## 2. APPLICABLE DOCUMENTS

The following technical documents, if referred to, are part of this specification. In case of a contradiction between this specification and the product drawing or this specification and the specified documentation then the product specification has priority.

### 2.1. TE Connectivity Documents

#### a) Drawings / Bill of material:

See Customer drawing for COMBO 1 INLET

DBAG basic number: A 000 340 69 03

TE number: 2387172-DBAG

#### b) Specifications

108-94519 Product Spec. TE actuator for charge inlets

114-13000 Application Specification Micro MATE-N-LOK Connectors

### 3. WIRES

The following designations are used in this specification. The illustrations are exemplary and schematically.

#### 3.1. Assessment of the wires

**To ensure the required electrical crimp contact ability the permissible maximum storage period of 8 months for unprocessed cable (referring to cable manufacturer production date) must be respected.**

#### 3.2. Wire selection

The contact system is released for the application with wires specified in point 3.4  
The released contact-wire-combinations and crimp parameters are given in table 1  
Other wires require the approval of the engineering department.  
The wires are applied as single wire terminations. Double terminations are not intended.

#### 3.3. Wire preparation

The wire must be stripped before crimping. The stripping length of the outer insulation and shield with tolerances is defined in the following Assembly Steps.

The insulation must be cut accurately and pulled off the conductor. Offcut of insulation may not remain on the conductor. Single strands may not be damaged, fanned out, cut or pulled out. Furthermore, the operator should avoid touching the bare single strands. Sticking out strands are not permitted.  
The single strands of the conductor may not be twisted.

#### 3.4. General Specifications of Prescribed Cables

##### **AC-Cable: Cross-section 3 x 6.0mm<sup>2</sup>**

Supplier:	Coroplast
Outer Diameter	14,1 <sub>-0,6</sub> mm
Cable description:	<i>FHLR2GCB2G 3x6.0mm<sup>2</sup></i> <i>acc. LV216-2 Tab. A5</i>
Coroplast Part No.:	9-2641 (3x6mm <sup>2</sup> )

##### **PE-Earth-Cable: Cross-section 16mm<sup>2</sup>**

Supplier:	Coficab
Outer Diameter	8.3 <sub>0,9</sub> mm
Cable description:	<i>FLY 16/0.21</i> <i>acc. LV112</i>
Part No.:	LLYF1600xxyy (xxyy -> color acc. to datasheet)

##### **Alternative PE-Earth-Cable: Cross-section 16mm<sup>2</sup>**

Supplier :	Coficab
Outer Diameter :	8.3 <sub>0,6</sub> mm
Cable description:	COFLEX-C T3 acc LV112-1
Part No.:	CF3C016xxyy (xxyy -> color acc. To datasheet)

Note regarding PE (PVC & XPO) insulation:

PG23 test is carried out according customer request and in conflict to specified requirements with PE cable which constricts during thermal aging in the sealing area (PVC & XPO insulation). To counteract this effect, the test samples were modified after the thermal aging in such a way, that the constricted area of the PE cable is moved out of the sealing area.

#### DC-HV-Cable : Cross-section 1 x 16,0mm<sup>2</sup>

Supplier: Coroplast  
Outer Diameter 10,2 -0,6 mm  
Cable description: *FHLR2GCB2G 16mm<sup>2</sup>/0.21 T180 0.6/0.9kV acc. LV216-2 Tab. A.2*  
Part No.: 9-2611 / 16mm<sup>2</sup>

#### DC-HV-Cable : Cross-section 1 x 50mm<sup>2</sup>

Supplier: Coroplast  
Outer Diameter 15,8 -0,6 mm  
Cable description: *FHLR2GCB2G 50mm<sup>2</sup> / 0.21 T180 0.6/0.9kV acc. LV216-2 Tab.A.2*  
Part No.: 9-2611 / 50mm<sup>2</sup>

#### 4. APPLICATION TOOLS

Required application tools are:

Minimum requirements for the press are 20t.

Wire Type	Wire Size [mm <sup>2</sup> ]	Construction	Stripping Length [mm]	Crimp height CH <sub>1</sub> [mm]	Wire std	Specification	Supplier	Contact P/N	Geometry	Applicator	Recommended crimping press
Pure copper	6	84 x 0.31mm	13,0 ±1	3,7 ±0,1	LV216-2	FHLR2GCB2G 3x6.0mm <sup>2</sup>	Coroplast	2-2293266-3	W	2326368-1	HV-20 2348822-1 <sup>1)</sup>
								2293266-4			
	16	512 x 0.21mm	16,0 ±0,5	5,10 ±0,1	LV216-2	FHLR2GCB2G single	Coroplast	2-2292541-4	W	2276149-2 <sup>2)</sup>	HV-20 2348822-1
								2-2292541-4			
								2-2292541-4			
								2-2292541-4			
	50	1600 x 0.21mm	23,5 ±0,5	9,4 ±0,15	LV216-2	FHLR2GCB2G, single	Coroplast	2292541-1	W	2276149-4 <sup>2)</sup>	
								2292541-1			
50	1600 x 0.21mm	23,5 ±0,5	8,0 ±0,15	LV216-2	FHLR2GCB2G, single	Coroplast	2292541-1	2B	2463538-1 [alternative: 2481936-1 <sup>3)</sup>		
							2292541-1				
Crimp Ferrule	50	1600 x 0.21mm	See step 5b	15.3 ±0.1	LV216-2	FHLR2GCB2G, single	Coroplast	2316553-2	-	2234183-1	HV-20 2348822-1 <sup>1)</sup>

Table 1

1) Crimping press "HV Crimping Machine 528008-4 with adapter" & related applicators acc 114-94438 Rev. D were used for product validation. They are still released for production, but no longer available in the TE Portfolio.

2) Not recommended for new applications / Use of existing tools still possible

3) Conversion of the old applicator PN 2276149-4 possible by exchanging of spare parts

## 5. REQUIREMENTS ON THE CRIMPED CONTACT

### 5.1. Terms of pin contact

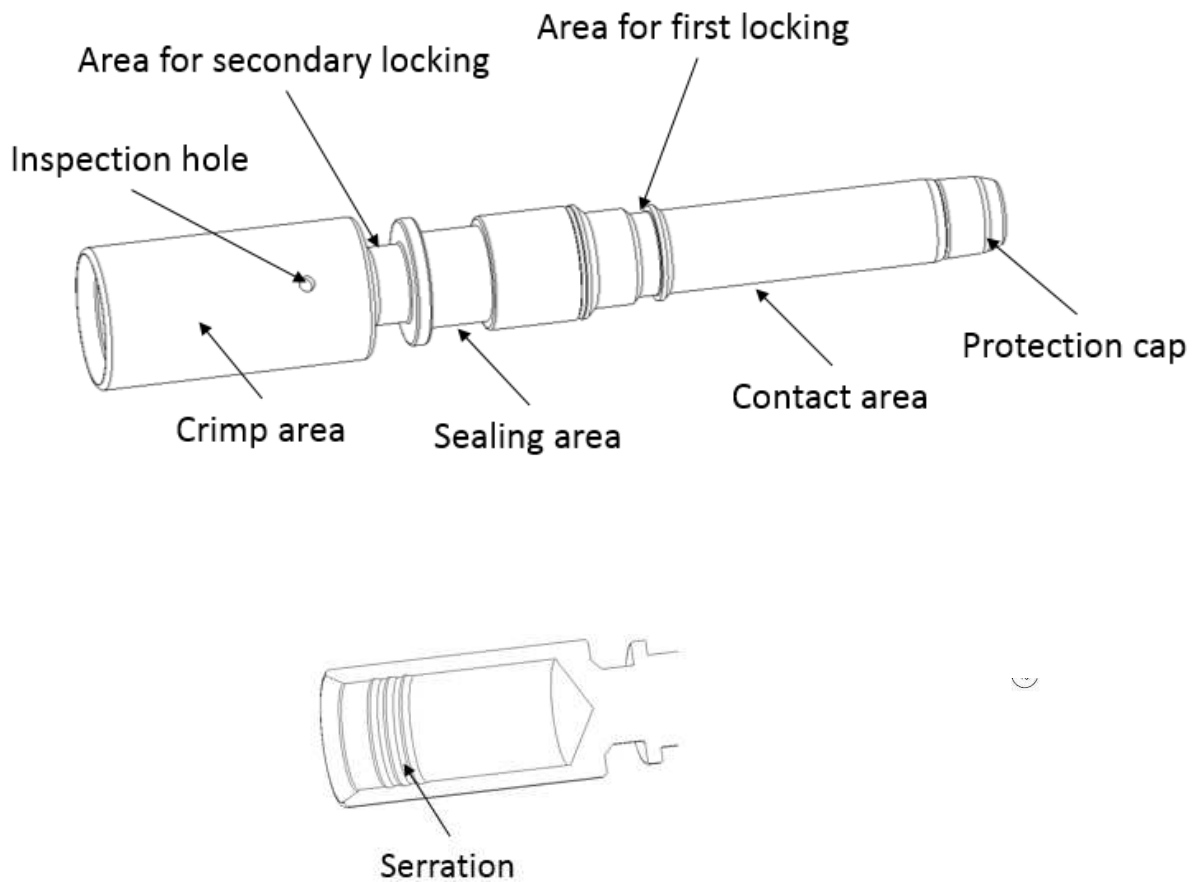

Figure 1

### 5.2. Conductor position

The single strands of the conductor are clamped in the wire barrel (drill hole at crimp area). Sticking out or on top crimped single strands are not permitted.

The wire end must be visible at the inspection hole before and after crimping. Insulation may not be inside of the crimping area.

### 5.3. Crimp data for the wire crimp

The crimp form, crimp heights including their corresponding tolerances as well as wire sizes are given in table 1.

The crimp height is the key quality feature of a crimp connection. The measurement allows a non-destructing examination and a continuous process inspection. It is provided for every wire size and contact.

Crimp height and width may also be measured in a cross-section image. The mechanical operated measurement though is preferred.

During the application process the crimp height must be checked. This is valid for each batch and after every change or switchover of contact reel or wire bundle or applicator respective it's setup or components. The crimp height must be measured over both extensions in middle of crimp (figure 2, also see point 5.9).

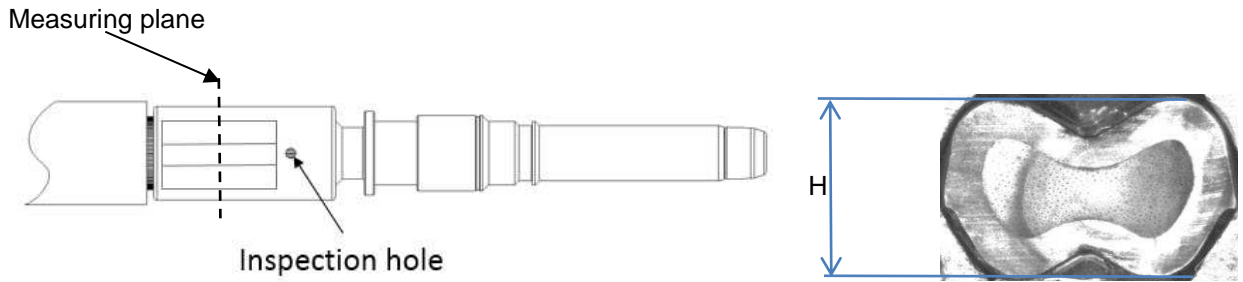

Figure 2

Crimp Die Sets are subject to wear and their condition and quality have to be monitored. Suspect and/or worn Die Sets have not to be used for the production of these crimps. Die Sets are available as spare parts.

5.4. Crimpposition

Contacts of diameter 6mm<sup>2</sup> have to be crimped with crimping tool position at middle of crimp area as shown.

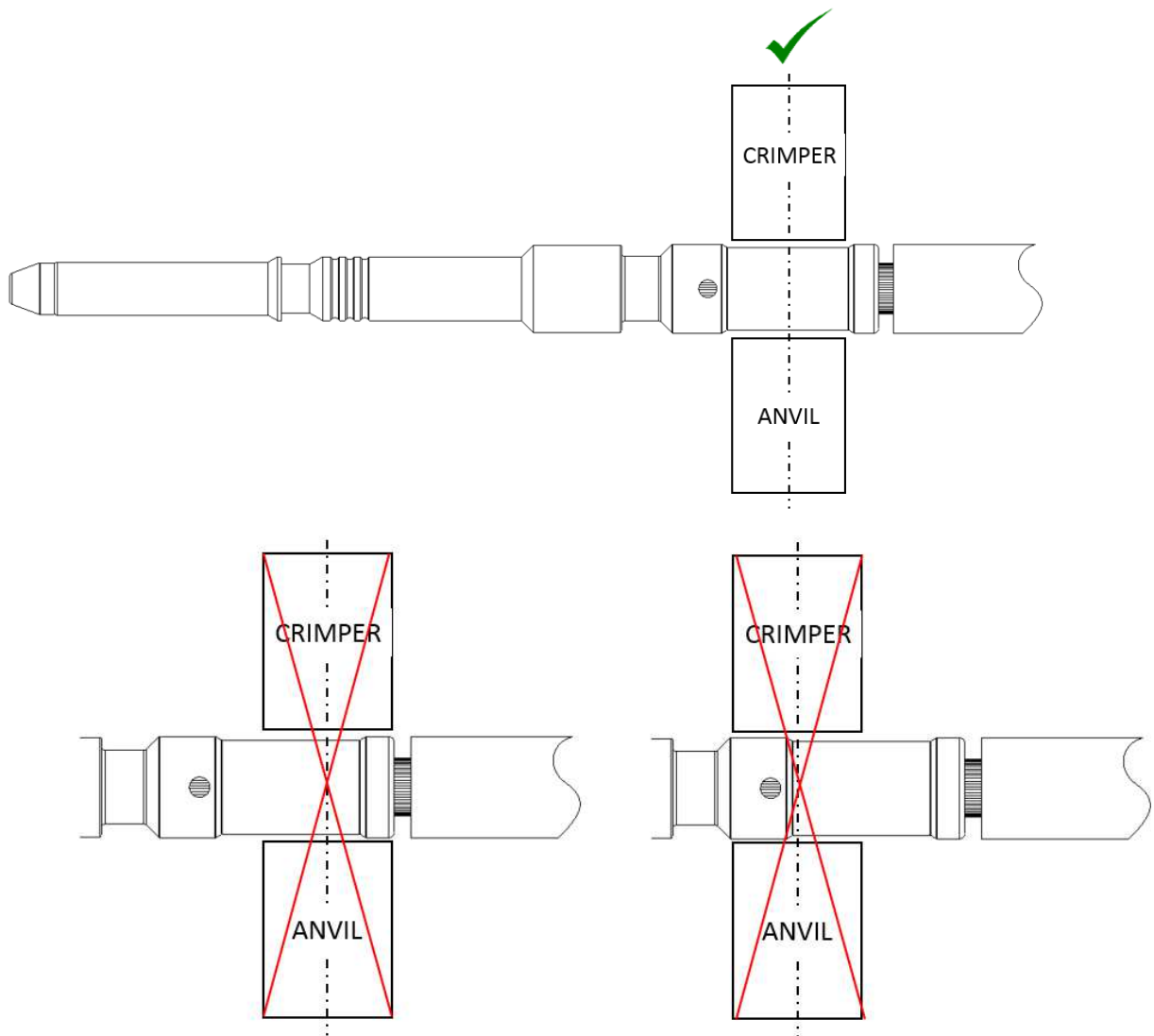

Figure 3



Contacts of wire diameter 16 mm<sup>2</sup> and 50mm<sup>2</sup> have to be crimped with crimping tool position at end of crimp area as shown.

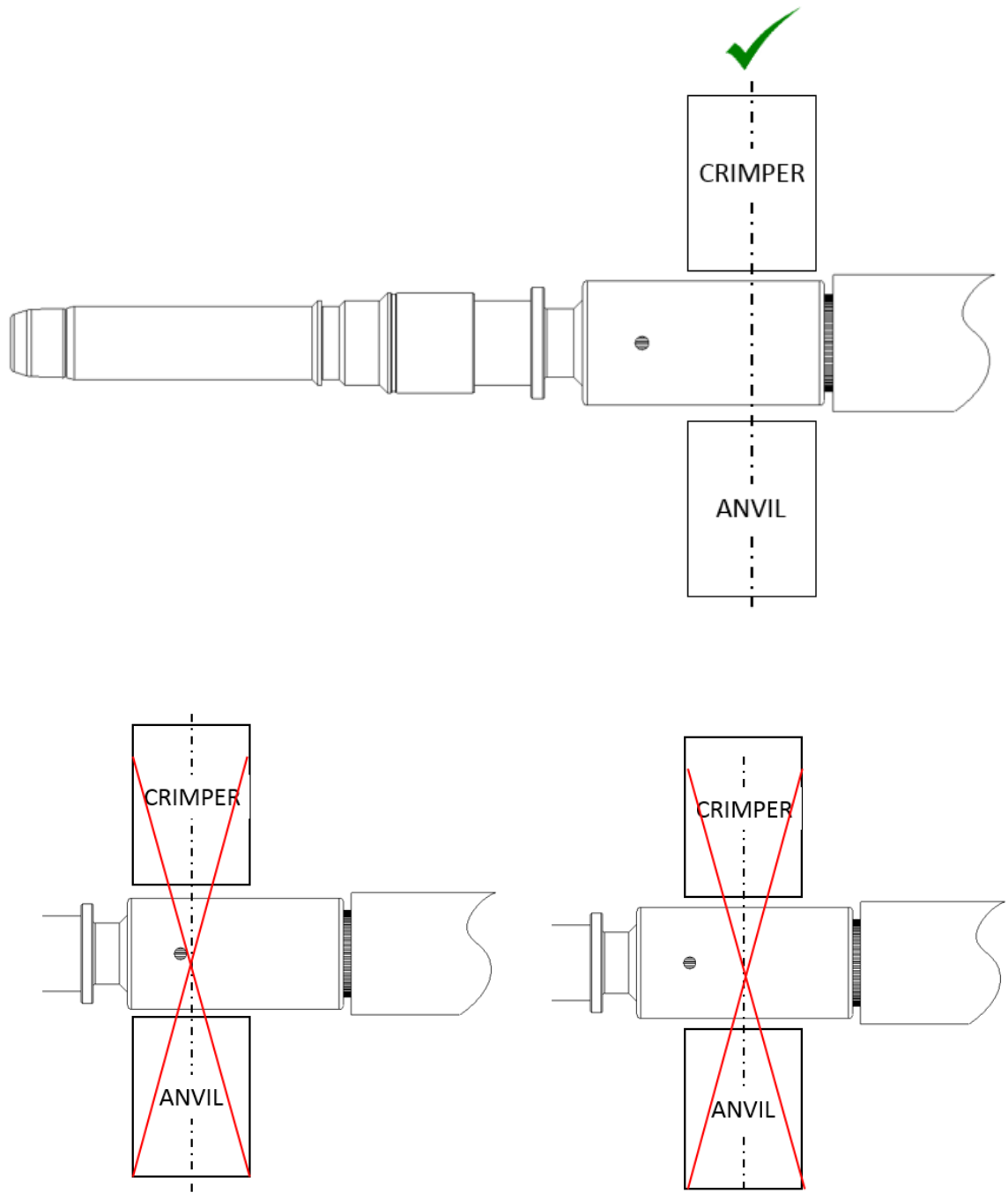
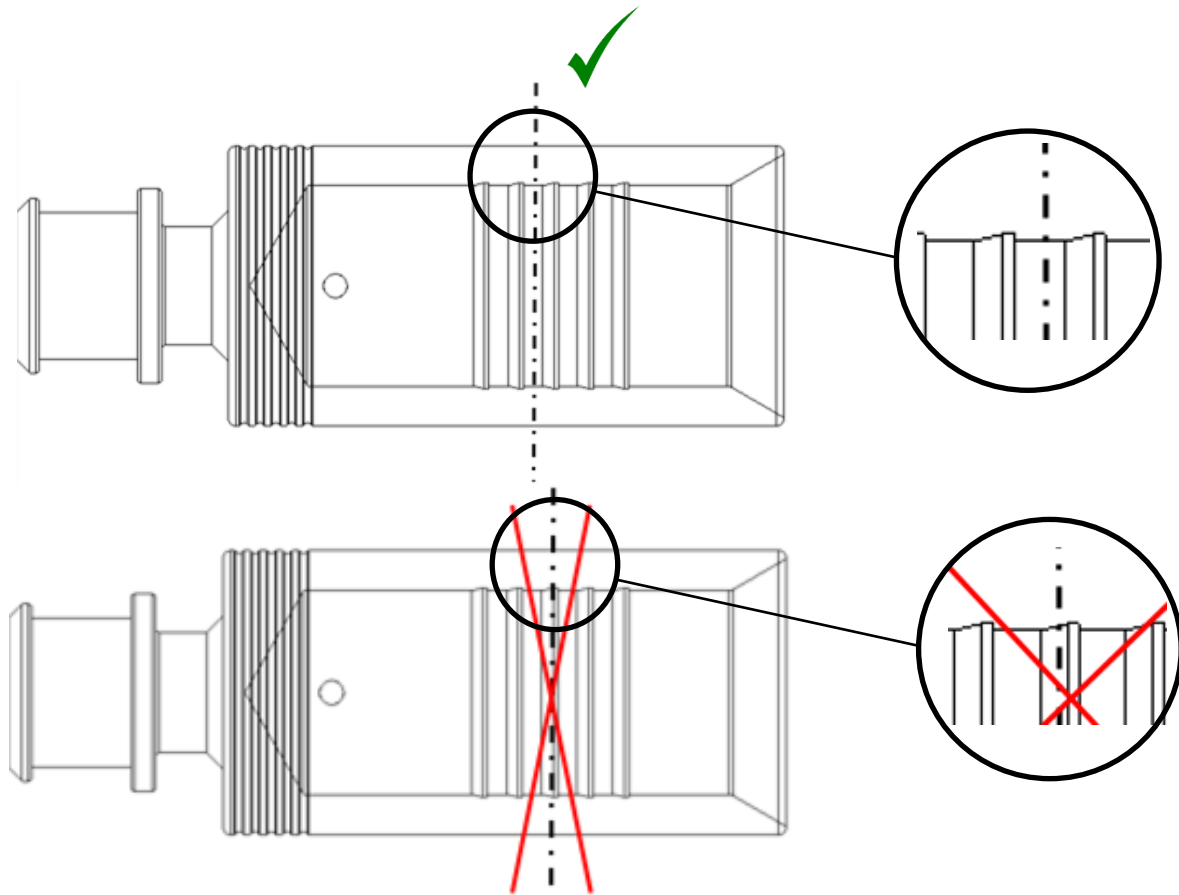

Figure 4

## 5.5. Cross sections

When creating cross sections, the correct grinding layer must be selected. The Grinding layer has to be at middle of crimp area and may not be inside of serration.



**Figure 5**

## 5.6. Contact area

During processing and following processing, the contact area may not be damaged or bended.

## 5.7. Sealing area

During processing and following processing, the sealing area may not be damaged or bended.

## 5.8. Shape and position tolerances

For 6 mm<sup>2</sup> and 16 mm<sup>2</sup> meeting the specific shape and position tolerances shown at figure 6 must be ensured before the contact is inserted into the housing.

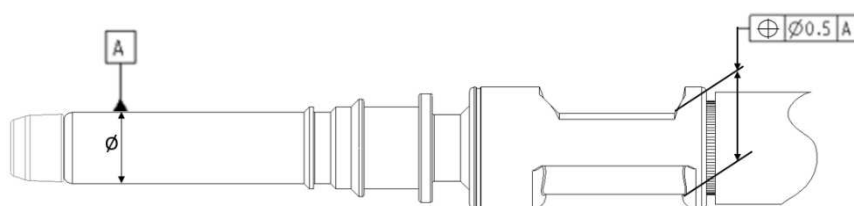

**Figure 6**

For 50 mm<sup>2</sup> meeting the specific shape and position tolerances shown at figure 7 must be ensured before the contact is inserted into the housing.

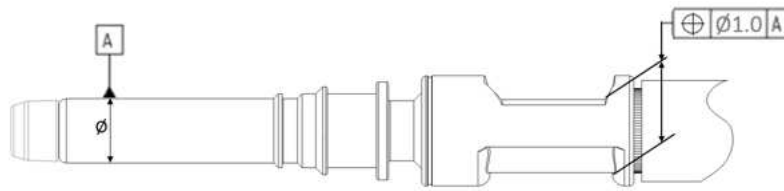

Figure 7

Measuring the shape and position deviation is not always necessary.

If the contact is obviously straight by eye a simplified shape and position functional test, at diameter 6mm<sup>2</sup>, can be performed by inserting it into a suitable housing cavity (crimp may not scrape the walls of secondary lock).

If contacts are bent during the application process exceeding the specification limits they may not be bent back and must be rejected.

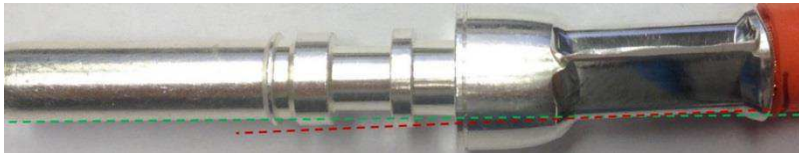

Figure 8

#### 5.9. Measuring equipment and measuring position

As measuring equipment for measuring crimp height, a digital caliper with accuracy of measuring 0.01mm is required. Measuring of crimp height, has to be done always in middle of crimp area, across whole crimp.

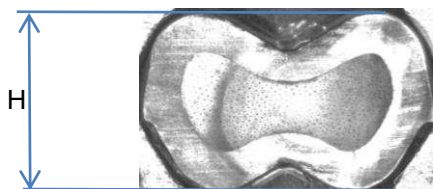

Figure 9

## 6. ASSEMBLY INSTRUCTIONS

In this chapter the way of assembly is described. All pictures in this chapter may differ from the specific product. The pictures illustrate the way of assembly and may not reflect all variants. The exact appearance of the components can be seen in the drawing documentation.

### 6.1. Assembly overview

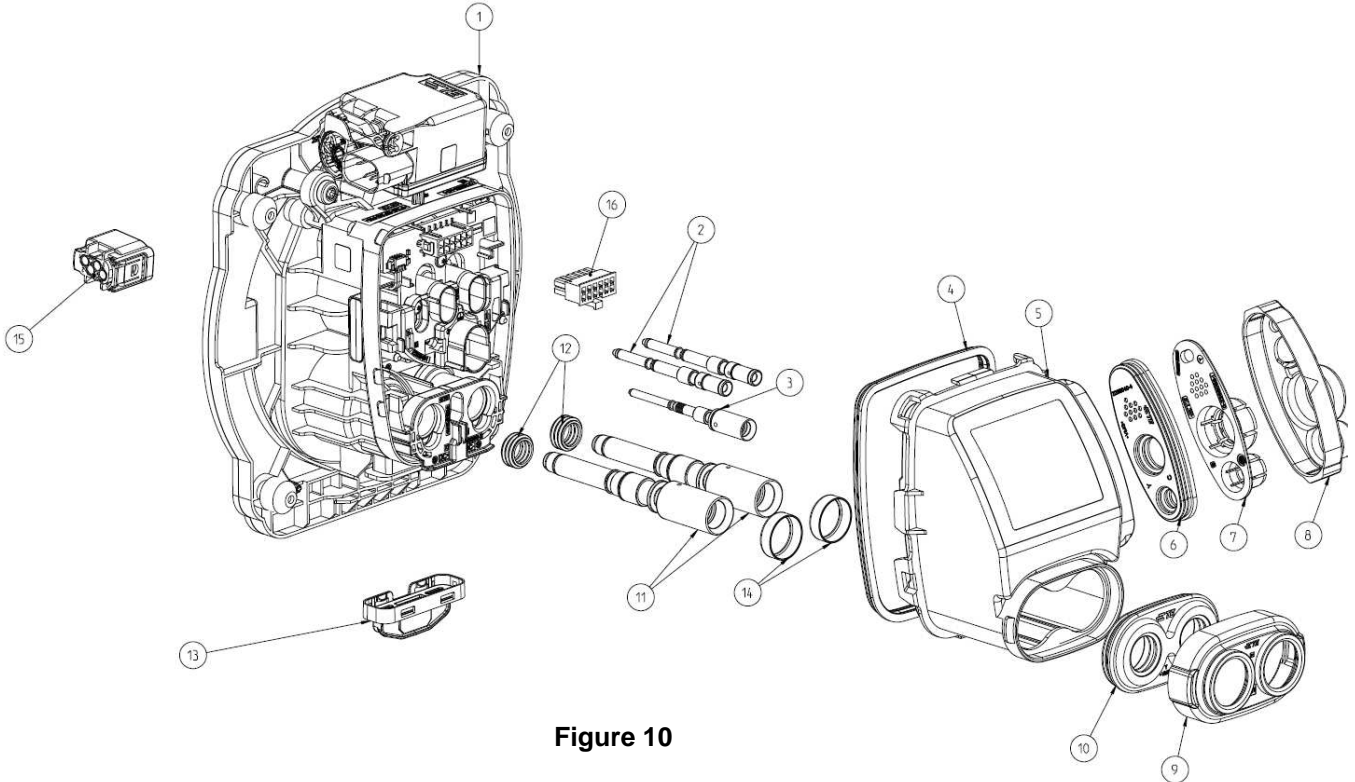

Figure 10

Pos.	Description / Bezeichnung
1	INLET HSG, COMBO1, ASSY
2	PIN DIA 3.6, AC
3	PIN DIA 2.8, PE
4	PERIPHERAL SEAL
5	CABLE EXIT
6	FAMILY SEAL, AC
7	STRAIN RELIEF, AC
8	COVER, CABLE SEAL, AC
9	COVER, CABLE SEAL, DC
10	FAMILY SEAL, DC
11	PIN, DIA8.0
12	SEALING
13	WATER DRAIN
14	OUTER FERRULE
15	4POS MQS ASSY acc. Spec. 108-94519 (additional part)
16	12P MICRO MNL ASSY acc. Spec. 114-13000 (additional part) <sup>1</sup>

Table 2

<sup>1</sup> TE Connectivity (TE) explicitly points out that this product as a single part is not an automotive product and therefore not subject to PPAP requirements. However, this product is technically capable, as it has been qualified according to automotive standards in the application described hereby in this document. Socket contact on harness side must be selected acc. to Micro MNL application specification 114-13000. It must be ensured that the chosen contact was validated acc. to the automotive requirements of the Slow-Motion Bending Test.

## 6.2. Assembly configuration cable exit

The inlet can be assembled with different cable exit directions. The required configuration can be chosen according to customer requirement.

### Configurations for cable exit AC 90° sideways:

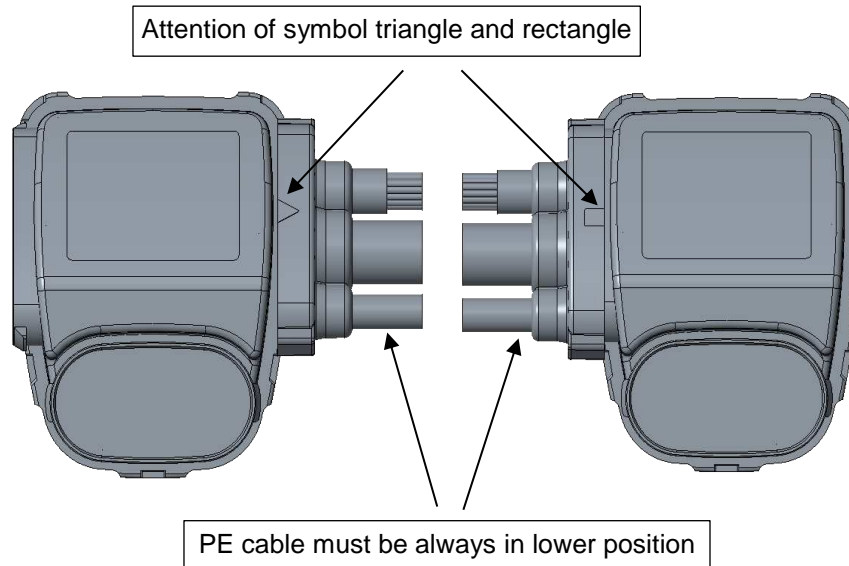

### Configurations for cable exit AC 20° downwards:

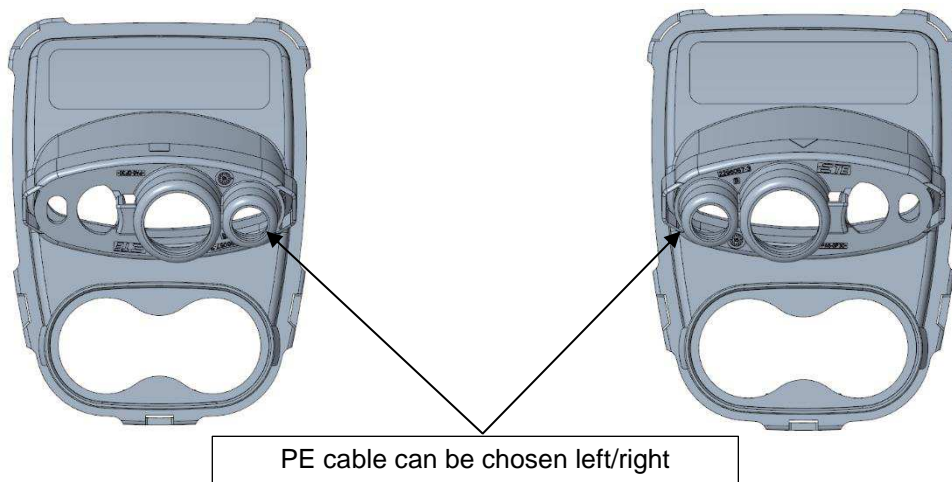

**Figure 11**

## 6.3. Parts to order

See 2.1.a

## 6.4. Security Advice

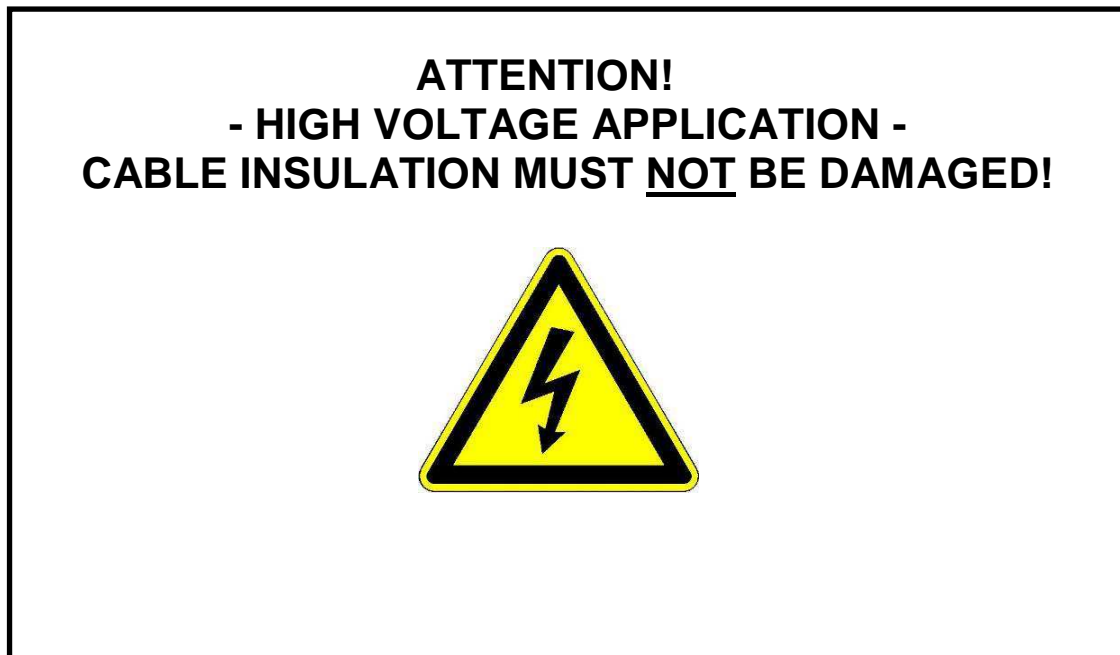

Figure 12

The assembly should only be performed by trained personnel.  
Avoid prolonged or repeated skin contact with silver plated contacts (wear protective gloves)!

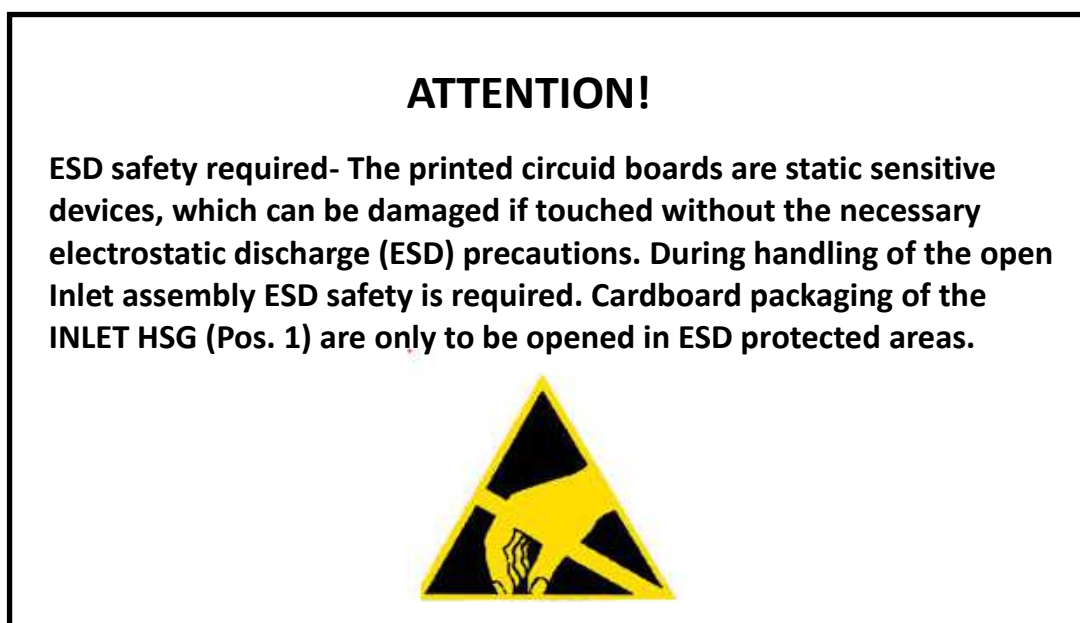

Figure 13

## 6.5. Assembly Steps

### Step 1

The COVER CABLE SEAL AC [Pos. 8], STRAIN RELIEF AC [Pos. 7] and FAMILY SEAL AC [Pos. 6] must be pushed over the signal wires, the ground wire and the AC-Multicore wire. Pay attention to place all wires at correct positions. (Figure 14).

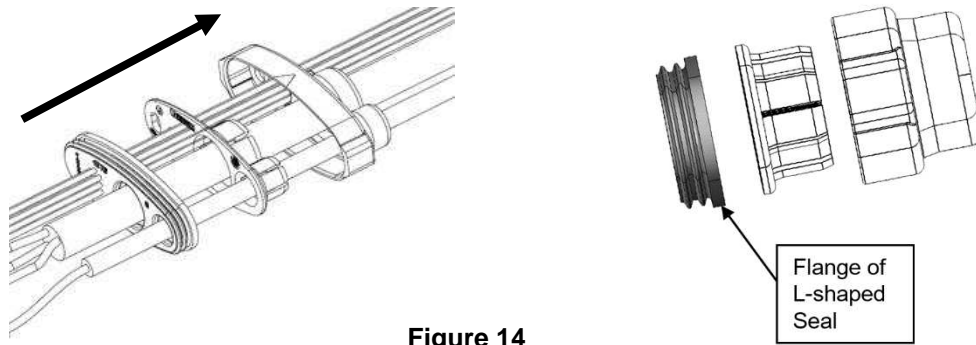

Figure 14

### Step 2

Preparation of AC multicore cable.

THE SINGLE BRAIDS MAY NOT BE CUT OR DAMAGED DURING DISMANTLE PROCESS.

Remove outer isolation, shield and filler of AC-multicore-cable acc. figure 15.

The given length of the single wires shown in table 3, ensures that the outer isolation of the multicore cable seals off to the FAMILY SEAL AC [Pos. 6]. A marking on outer isolation in a distance "C" (or in a offset to "C") to the cut off position is recommended to ensure the proper position of the outer isolation in the FAMILY SEAL AC [POS. 6].

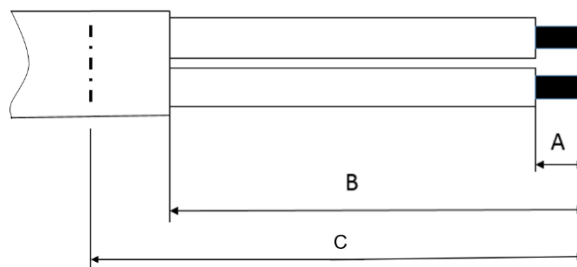

Figure 15

Wire Size	Removal of isolation "A"	Length of single wires "B"	Position outer end of COVER [POS.9] "C"
6 mm <sup>2</sup>	13 +/-1 mm	68 +/-2 mm	96 +/-4 mm

Table 2

**Alternative** to prepare cable according step 2 figure 15, is it also possible to prepare cable similar figure 16. In this case it is necessary to protect complete overlapping shield braid with tape (e.g. Certoplast 9mm). A marking on outer isolation in a distance "E" (or in an offset to "E") to the cut off position is recommended to ensure the proper position of the outer isolation in the FAMILY SEAL AC [POS.6].

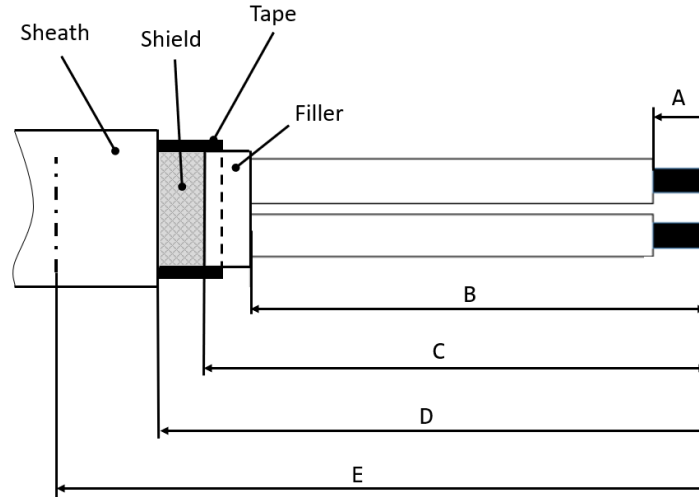

Figure 16

Variant of CABLE EXIT [POS. 6]	Wire Size	Removal of isolation "A"	Length to filler "B"	Length to shield braid "C"	Length to outer insulation "D"	Position outer end of COVER [POS.9] "E"
90° sideways	6 mm <sup>2</sup>	13 +/-1 mm	65 +/-2 mm	73 +/-2 mm	78 +/-2 mm	106 +/-4 mm
20° downwards	6 mm <sup>2</sup>	13 +/-1 mm	55 +/-2 mm	63 +/-2 mm	68 +/-2 mm	96 +/-4 mm

Table 3



Crimp the conductors to the PIN DIA3.6 POWER AC [Pos. 2] with the specified tools. Care shall be taken that all braids are caught in the crimp. Not inserted braids may jeopardize HV requirements! Wires shall be completely inserted to be visible through the inspection hole (Figure 17). Crimp height H shall be conform to dimension acc. table 1.

*Any damage of the wire isolation must be avoided*

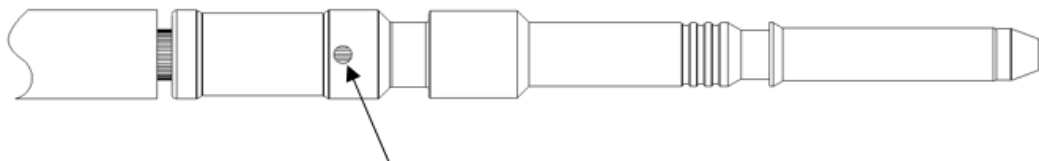

Inspection hole

Figure 17



**Step 3**

Preparation of PE single wire.

Dismantle PE-single wire cable acc. Figure 18.

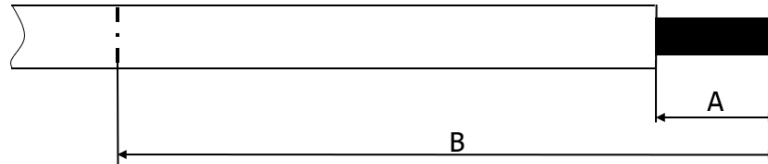

**Figure 18**

THE SINGLE BRAIDS MAY NOT BE CUT OR DAMAGED DURING DISMANTLE PROCESS.

Wire Size	Variant of CABLE EXIT [POS. 6]	Removal of insulation "A"	Position outer end of COVER [POS.9] "B"
16 mm <sup>2</sup>	AC 90° (rect. right / left)	16.0 +/-1 mm	95 mm REF
	AC 20° down (straight)		95 mm REF

**Table 4**



Crimp conductor on PIN DIA 2,8 POWER PE [Pos. 3] with the specified tools. Care shall be taken that all braids are caught in the crimp. Not inserted braids may jeopardize HV requirements! Wires shall be completely inserted to be visible through the inspection hole (Figure 19). Crimp height H shall be conformable to dimension

*Any damage of the wire isolation must be avoided*

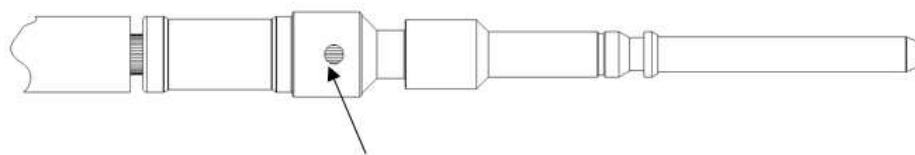

Inspection hole

**Figure 19**

**Step 4**

Preparation of LV signal wires and assembly to MNL connector

Dismantle LV single wires and crimp the corresponding contact acc. to application spec. 114-13000. See also Figure 20 and Table 6.

The single strands must not be cut or damaged during wire stripping!

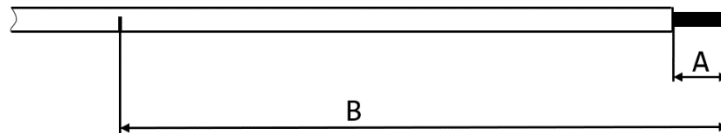
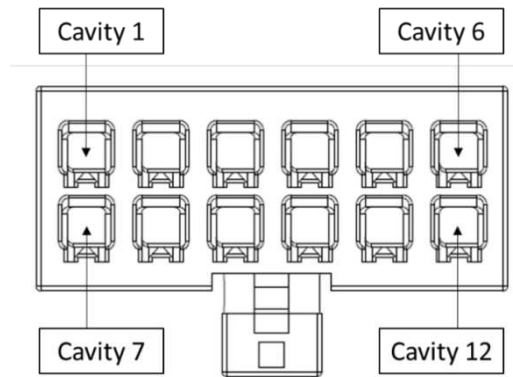

**Figure 20**

Wire Size	Variant of CABLE EXIT [POS. 6]	Removal of isolation "A"	Position outer end of COVER [POS.9] "B"
0,35mm <sup>2</sup>	AC 90° (rect. right / left)	Acc. 114-13000	80 mm REF
	AC 20° down (straight)		75 mm REF

**Table 5**

Push crimped MNL contacts into the Micro MNL connector housing acc. to application spec 114-13000. Pinning acc. to Figure 21 and Table 7.

**Figure 21**

Cavity no.	Function
1	LED_DRV1 (Green)
2	LED_DRV2 (Red)
3	n/a
4	GND_LED
5	LED_DRV4 (White)
6	Hall/T_DC1
7	Proxi
8	Temp_GND
9	T_AC2/T_DC2
10	T_AC1
11	PE_S
12	CP

**Table 6**

**Step 5**

There are 3 different ways of preparation of DC-HV-Cables necessary:

For DC-HV-Cables of 16mm<sup>2</sup> in combination with CABLE EXIT AC 90° SIDEWARDS please see Step 5a.  
 For DV-HV-Cables of 50mm<sup>2</sup> in combination with CABLE EXIT AC 90° SIDEWARDS please see Step 5b.  
 For DV-HV-Cables of 50mm<sup>2</sup> in combination with CABLE EXIT AC 20° DOWN please see Step 5c.

**Step 5a**

**DC-HV-Cables of 16mm<sup>2</sup> in combination with CABLE EXIT AC 90° SIDEWARDS.**

THE SINGLE BRAIDS MAY NOT BE CUT OR DAMAGED DURING DISMANTLE PROCESS.

Remove outer isolation and shielding braid of DC-HV-Cable acc. dimension B, remove inner isolation acc. dimension A (figure 22).

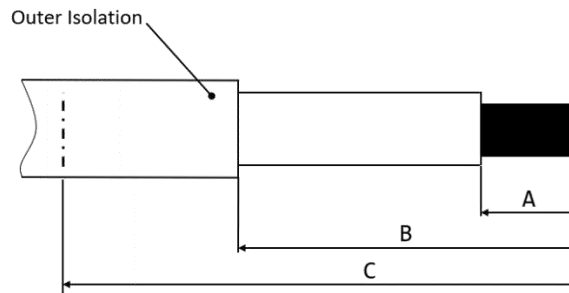
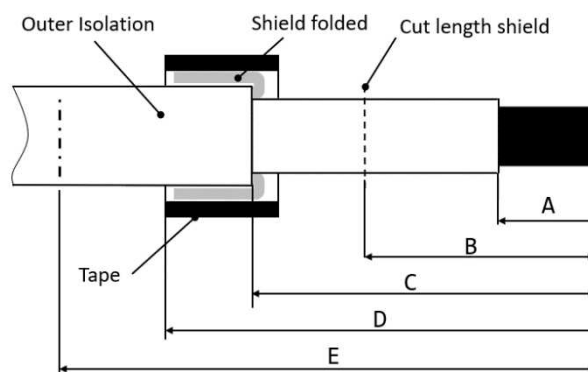

**Figure 22**

Wire Size	Removal of isolation "A"	Removal of shielding dim "B"	Position outer end of COVER [POS.10] "C"
16mm <sup>2</sup>	16 +/-1 mm	25 +/-1 mm	53 mm REF

**Table 7**

**Alternative** to prepare cable according step 5a figure 22, is it also possible to prepare cable similar figure 23. In this case it is necessary to protect complete backward folded shield braid (folded over outer isolation) with tape (e.g. Certoplast 9mm).



**Figure 23**

Wire Size	Removal of isolation "A"	Length of shield braid (before folding backward) "B"	Length of outer isolation "C"	Pos.Tape "D"	Position outer end of COVER [POS.10] "E"
16 mm <sup>2</sup>	16 +/-1 mm	21 +/-2 mm	26 +/-2 mm	max. 38mm	53 mm REF

**Table 8**

Take care, to protect single conductors and braid against contamination, bending and other damages until crimping process.

The COVER CABLE SEAL DC (Pos. 9) and FAMILY SEAL DC [Pos. 10] must be pushed over the DC-HV-wires (figure 24)

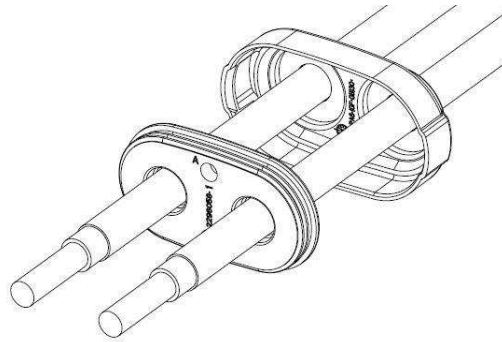

**Figure 24**



Crimp the conductors to the PIN DIA8.0 CONTACT [Pos. 11] with the specified tools. Care shall be taken that all braids are caught in the crimp. Not inserted braids may jeopardize HV requirements! Wires shall be completely inserted to be visible through the inspection hole (figure 25). Crimp height H shall be conform to dimension acc. table 1.

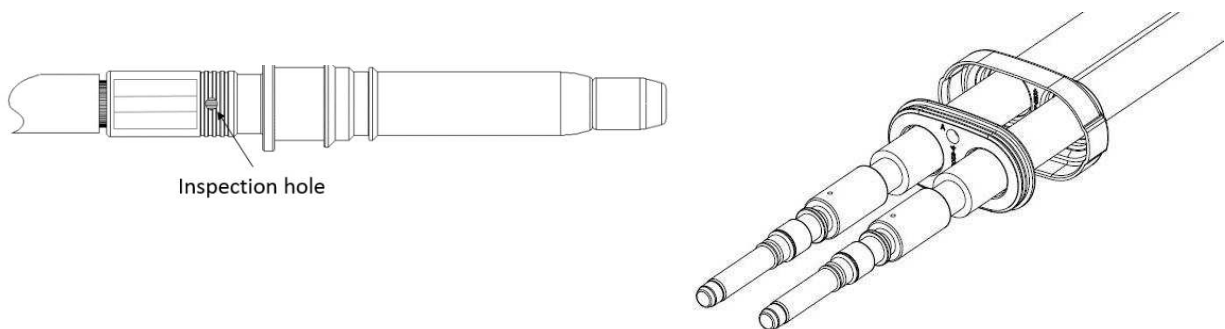

**Figure 25**

**ATTENTION:**

Any damage of the wire isolation must to be avoided!

**Step 5b**

**DC-HV-Cables of 50mm<sup>2</sup> in combination with CABLE EXIT AC 90° SIDEWARDS.**

THE SINGLE BRAIDS MAY NOT BE CUT OR DAMAGED DURING DISMANTLE PROCESS.

Remove outer isolation and shielding-foil of DC-HV-Cable acc. dimension B (figure 26).

Remove inner isolation acc. dimension A (figure 26).

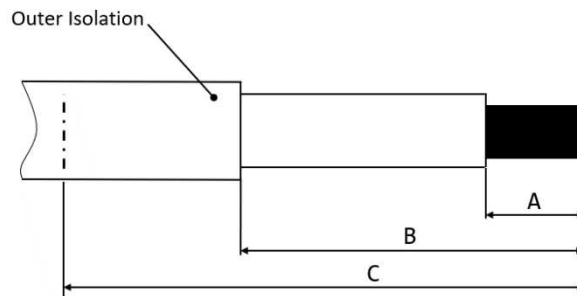

**Figure 26**

Wire Size	Removal of isolation "A"	Removal of outer insulation "B"	Position outer end of COVER [POS.10] "C"
50mm <sup>2</sup>	23 +/-0,5 mm	29 +/-0,5 mm	50 mm REF

**Table 9**

Take care, to protect single conductors and braid against contamination, bending and other damages until crimping process.

The shielding braid must not be combed out. Fold back the shielding braid over the outer insulation of the cable.

The COVER CABLE SEAL DC [Pos. 9] and FAMILY SEAL DC [Pos. 10] must be pushed over the DC-HV-wires (figure27)

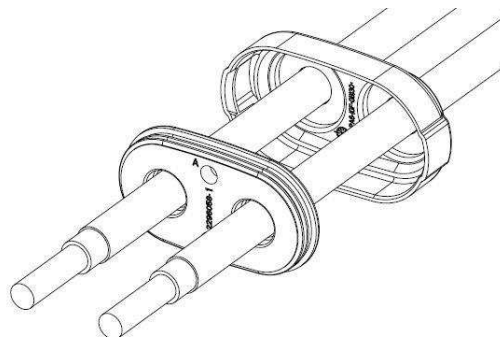

**Figure 27**



### Processing PIN DIA8.0 CONTACT [Pos. 12]

Crimp the conductors to the PIN DIA8.0 CONTACT [Pos. 11] with the specified tools. Care shall be taken that all braids are caught in the crimp. Not inserted braids may jeopardize HV requirements! Wires shall be completely inserted to be visible through the inspection hole (Figure 28).

Crimp height H shall be conform to dimension acc. table 1.

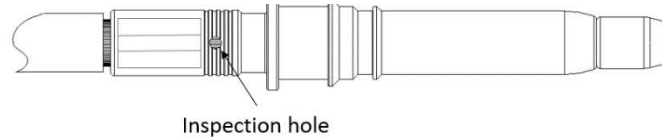

Figure 28

### Processing OUTER FERRULE [POS. 14]

Push then the OUTER FERRULE [Pos. 14] over the shielding braid.

Crimp OUTER FERRULE [Pos. 14]. The crimp quality has to be conform to TE Spec. 109-18212.

Deviated symmetrical requirement based on buckling is allowed, as shown as example in figure 29 of crimped ferrule. Buckle A and B can also differ from each other.

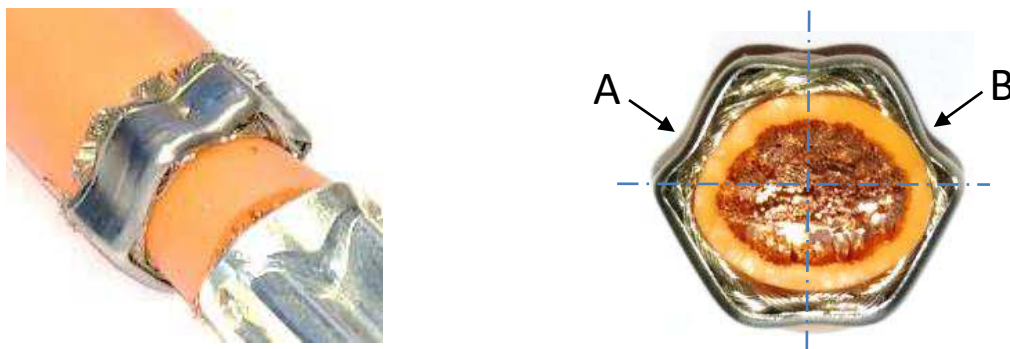

Figure 29

The crimp height according table 11 has to be measured according Chapter 5.4 of TE Spec. 109-18212 and it has to meet the following requirement.

Hex Crimp Height H	Measurement position in section plane of embossed dimple
 $15.3 \pm 0.1 \text{ mm}$	

Table 10

Take care to distance between OUTER FERRULE [Pos. 14] and Pin contact [Pos. 11] as shown in figure 30.

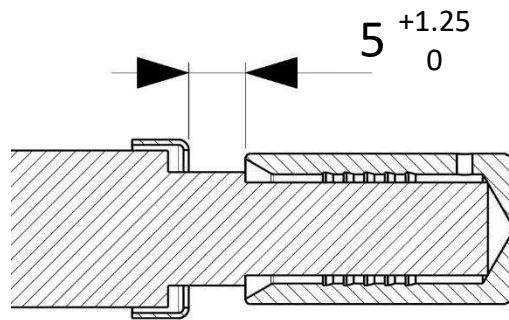

**Figure 30**

Free shielding braid longer than outer ferrule, must be cut as shown in Figure 31

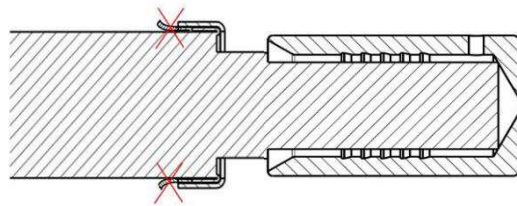

**Figure 31**

**ATTENTION:**

Any damage of the wire isolation must to be avoided!

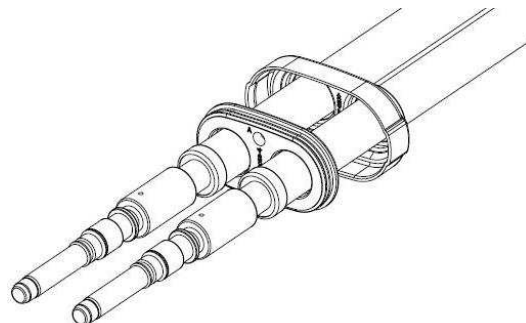

**Figure 32**



**Step 5c**
**DC-HV-Cables of 50mm<sup>2</sup> in combination with CABLE EXIT AC 20° DOWN (STRAIGHT)**

THE SINGLE BRAIDS MAY NOT BE CUT OR DAMAGED DURING DISMANTLE PROCESS.

Remove outer isolation and shielding braid of DC-HV-Cable acc. dimension B, remove inner isolation acc. dimension A (figure 33).

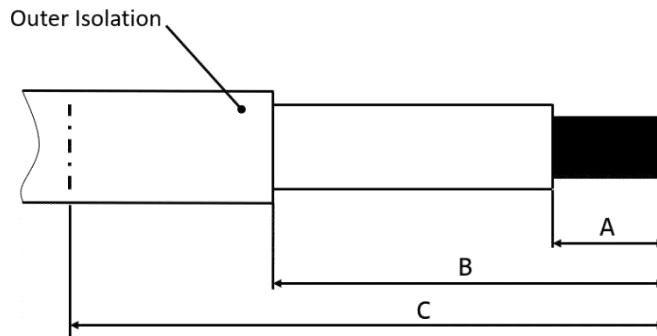
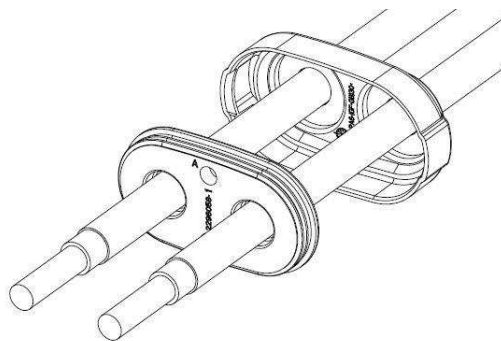

**Figure 33**

Wire Size	Removal of insulation "A"	Removal of outer insulation "B"	Position outer end of COVER [POS.10] "C"
50mm <sup>2</sup>	23 +/-0,5 mm	29 +/-0,5 mm	61 mm REF

**Table 11**

Take care, to protect single conductors and braid against contamination, bending and other damages until crimping process.

The COVER CABLE SEAL DC [Pos. 9] and FAMILY SEAL DC [Pos. 10] must be pushed over the DC-HV-wires (figure 34)

**Figure 34**

**Alternative** it is also possible to process with folded shielding braid and OUTER FERRULE [Pos. 14] according step 5b described in "Processing OUTER FERRULE [Pos.14]" .



Crimp the conductors to the PIN DIA8.0 CONTACT [Pos. 11] with the specified tools. Care shall be taken that all braids are caught in the crimp. Not inserted braids may jeopardize HV requirements! Wires shall be completely inserted to be visible through the inspection hole (Figure 35). Crimp height H shall be conform to dimension acc. table 1.

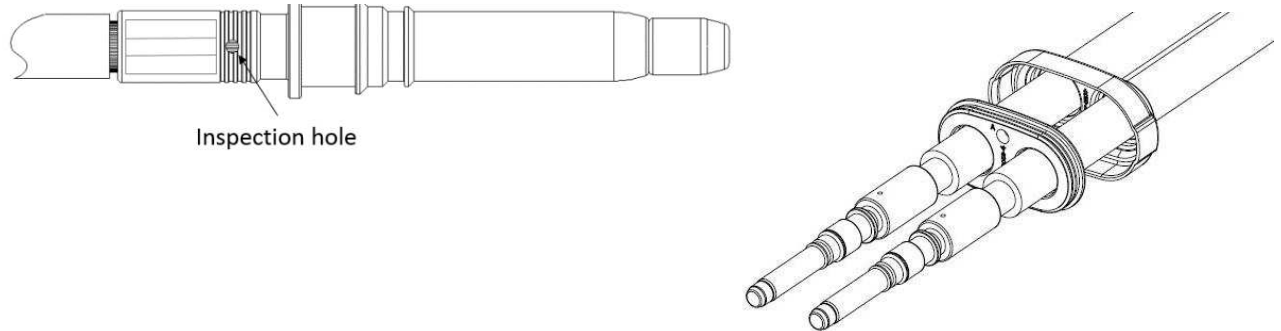

Figure 35

**ATTENTION:**

Any damage of the wire isolation must to be avoided!

**Step 6 (for all DC-HV-Cable Assemblies)**

The two SEALINGS [Pos. 12] have to be placed on the PIN DIA8.0 CONTACTS. Ensure correct orientation acc. Figure 36 (sealing libs on outside).

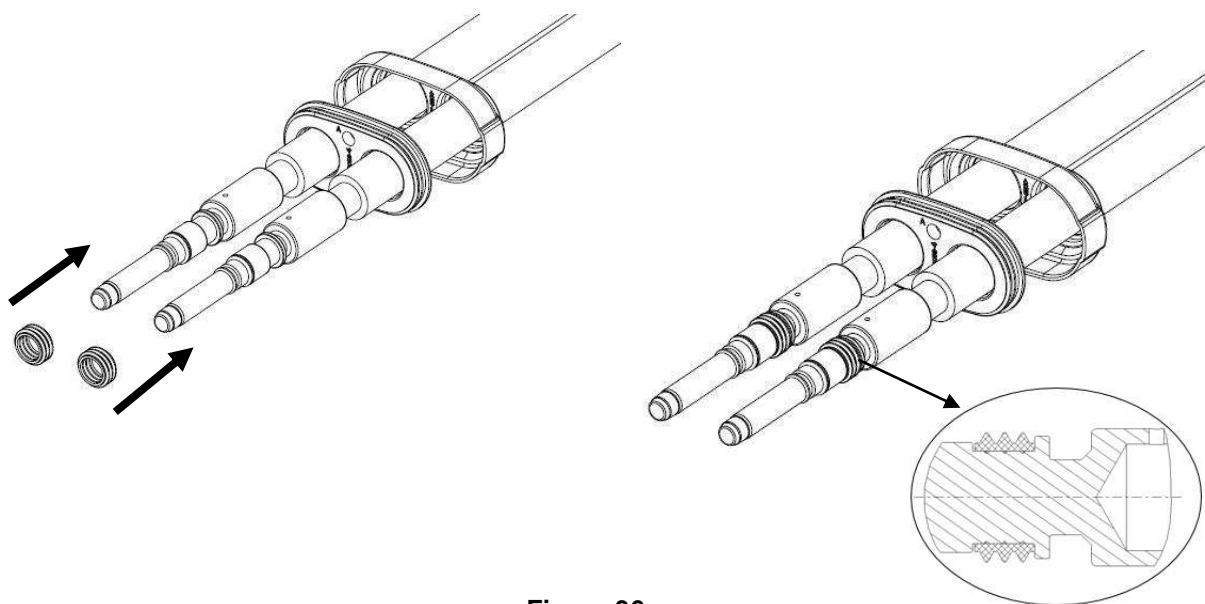
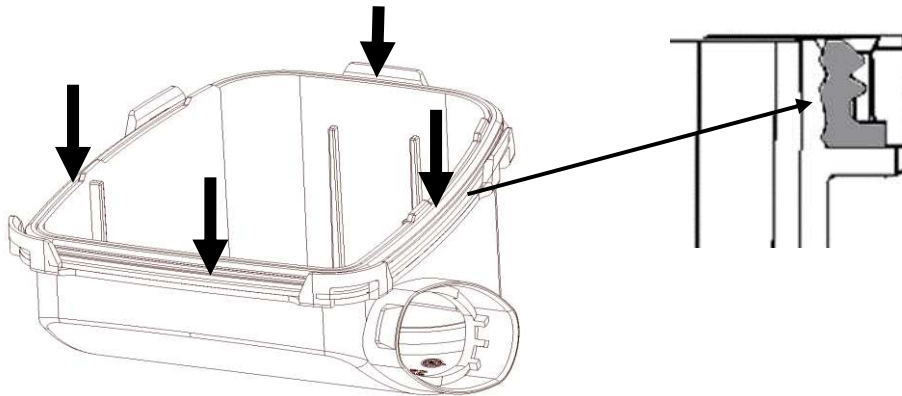

Figure 36

**Step 7**

Assemble the Radial Seal [Pos. 4] to the Cable Exit Cover [Pos. 5]. Radial Seal should be properly seated into the Collar of the Cable Exit Cover. Ensure also correct orientation of seal acc. figure 37.

**Figure 37****Step 8**

Pass the SIGNAL CONNECTOR, AC POWER PINS and PE PIN through the AC slot and DC pins through DC slot in Combo Cable Exit [Pos. 5]

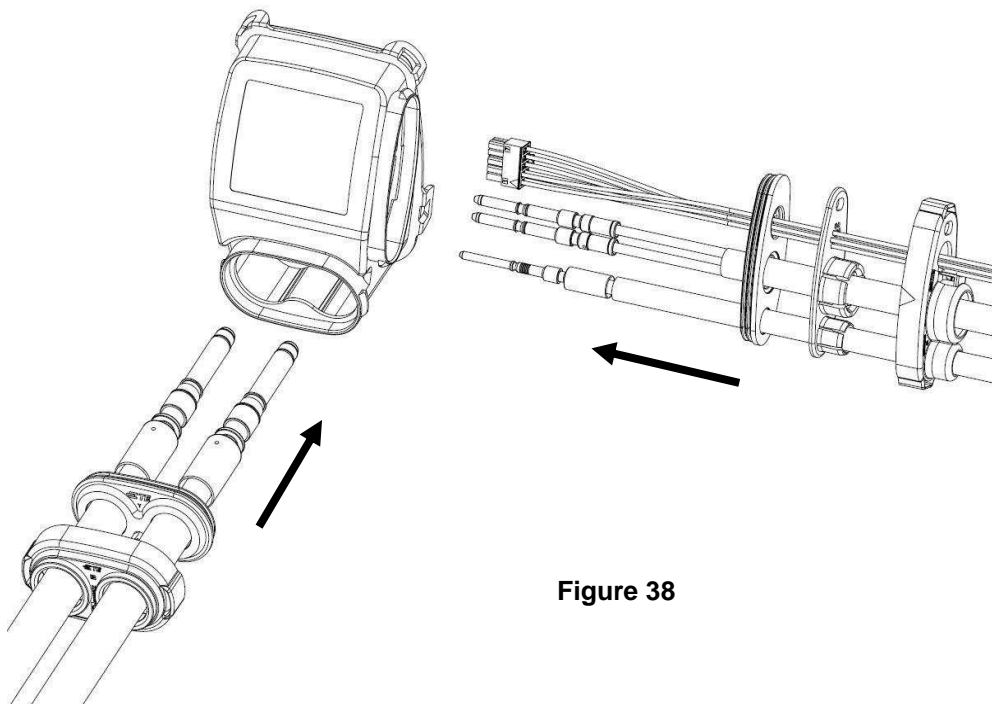

**Attention:** To mount the contact DC in contact cavity, you must wear firm gloves.

**Figure 38**

**Step 9**

Insert the Contacts from the rear side into the Inlet Housing (figure 39) according to the cavity description into their locking position.

**ATTENTION:** The correct contact positions must be ensured BEFORE pushing the contacts into locking their cavities in locking position.

In case of wrong positioning of the contacts the complete assembly must be scrapped. There is no rework allowed (risk of damaging contacts and/or locking geometry in housing)!

To ensure that the contacts are correctly inserted, pull and push with a low force on the cables (max. 10N) and check visually on the front side that the locking lances are properly engaged in the related pin groove. The locking lances must not stay outside of the grooves (figure 40). Ensure the Seals are properly positioned in their seats and are not damaged!

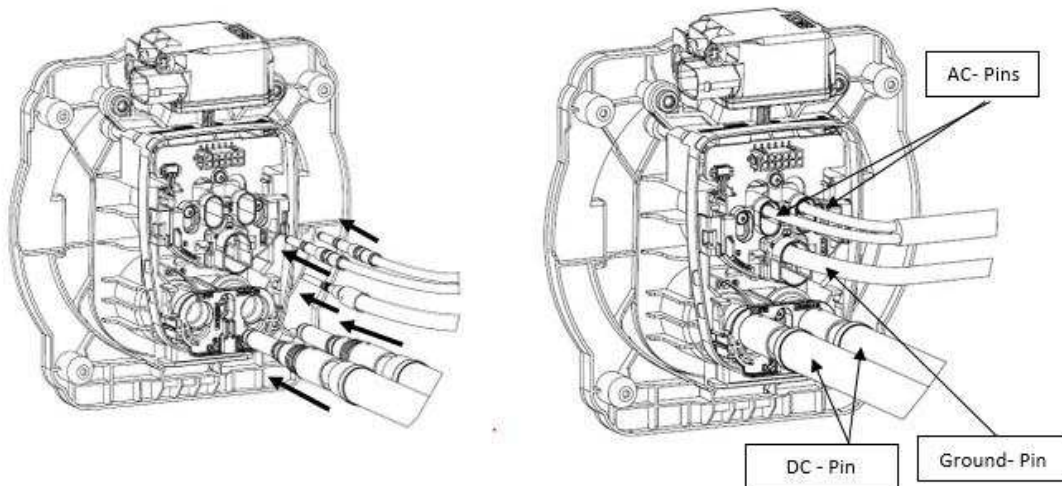
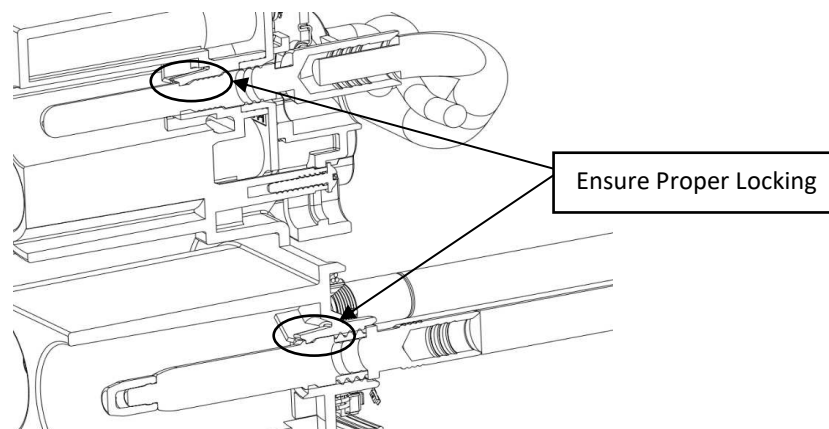

ESD safety required - The printed circuit boards are static sensitive devices, which can be damaged if touched without the necessary electrostatic discharge (ESD) precautions. During handling of the open inlet assembly ESD safety is required.

**Figure 39**

**Figure 40**

**Step 10**

After the contacts have been controlled for correct positioning and locking, both **SECONDARY LOCKS** have to be pushed upwards (figure 41). Ensure that all hooks are properly engaged with the inlet housing, which must be controlled by the double audible click and by visible inspection (figure 42).



**ATTENTION:** The Pin position has to be ensured **BEFORE** locking the Secondary Lock!



ESD safety required - The printed circuit boards are static sensitive devices, which can be damaged if touched without the necessary electrostatic discharge (ESD) precautions. During handling of the open inlet assembly ESD safety is required.

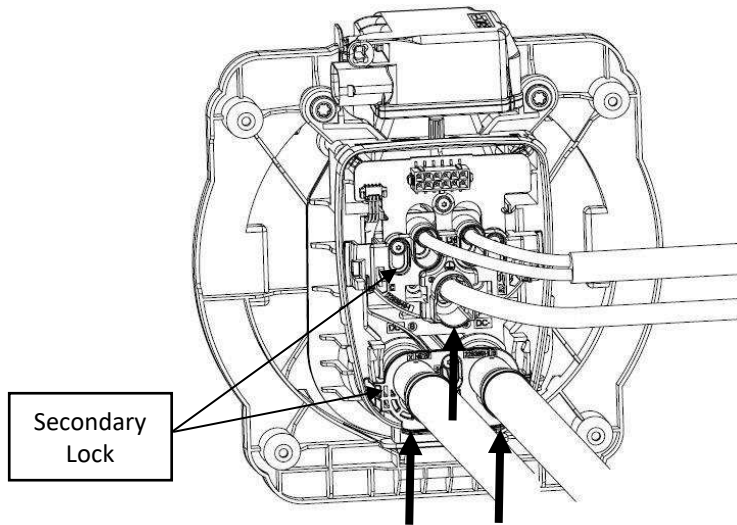

**Figure 41**

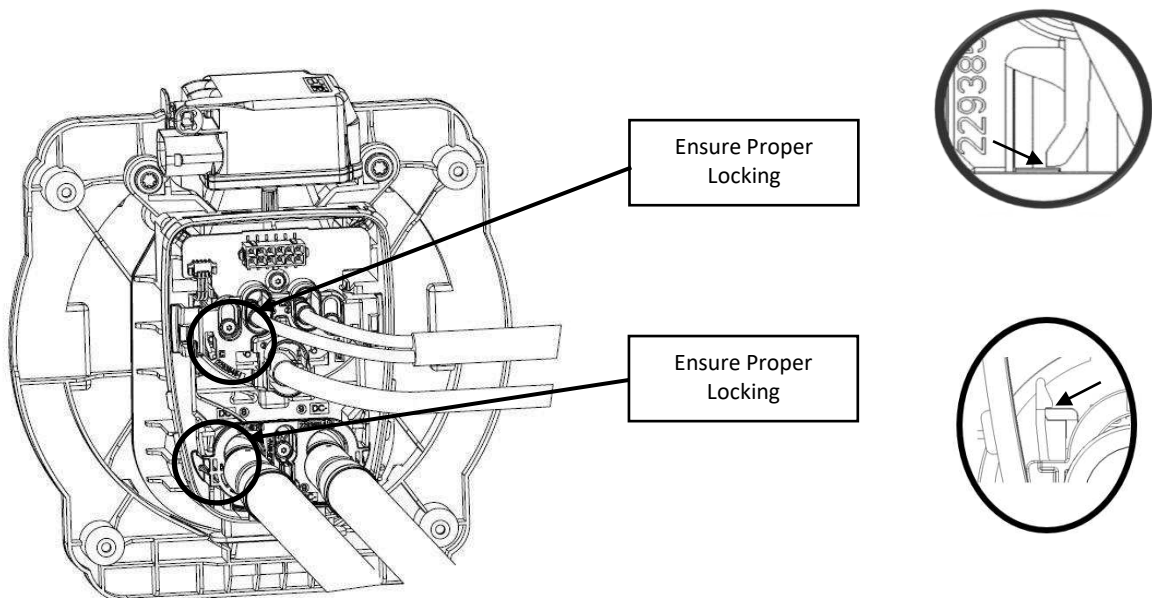

**Figure 42**

**Step 11**

Connect Micro Mate-N-Lok Connector to PCB-Header. Ensure that hook is properly engaged with the mating part in PCB (figure 43).

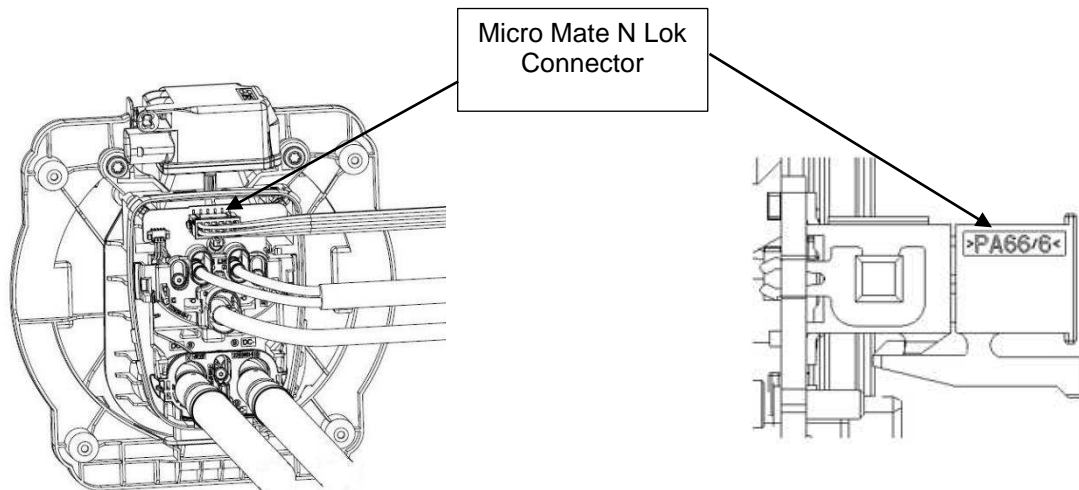

ESD safety required - The printed circuit boards are static sensitive devices, which can be damaged if touched without the necessary electrostatic discharge (ESD) precautions. During handling of the open inlet assembly ESD safety is required

**Figure 43**
**Step 12**

Recommended procedure for the CABLE EXIT assembly [Pos. 5] (with radial seal [Pos. 4]) to the Inlet Housing [Pos. 1] (Figure 44).

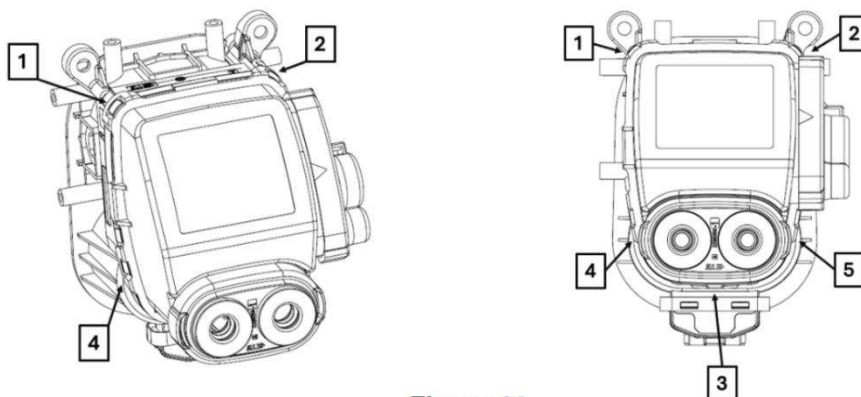
**Figure 44**

As seen in Figure 44, follow the steps listed below to close the cable exit with less press-on-force:

- Locate and slide in the cable exit to lock the positions 1 and 2
- Then press position 3 to lock
- At last press positions 4 & 5 for final lock.

**Alternative procedure** - Assemble the CABLE EXIT [Pos. 5] (with radial seal [Pos. 4]) to the Inlet Housing [Pos. 1] (Figure 44a). Press CABLE EXIT down at specified faces. Ensure that all 5 hooks are properly engaged. Typical press-on-force = 250N; max. press-on-force = 500N

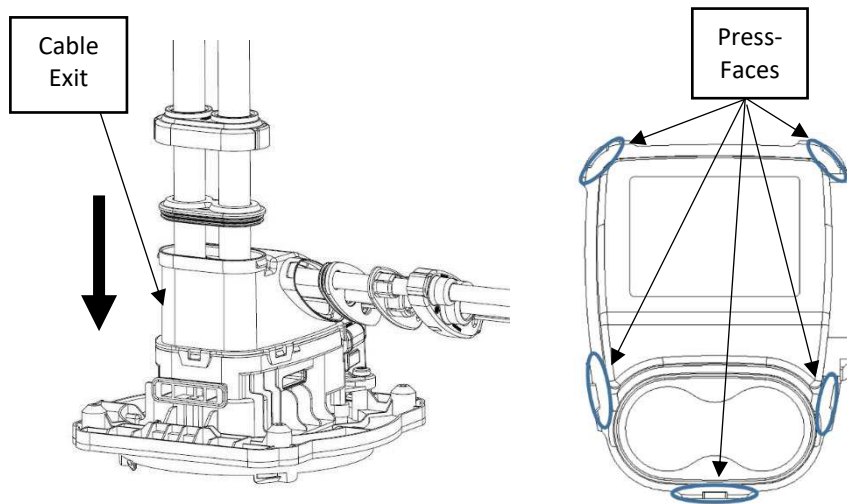
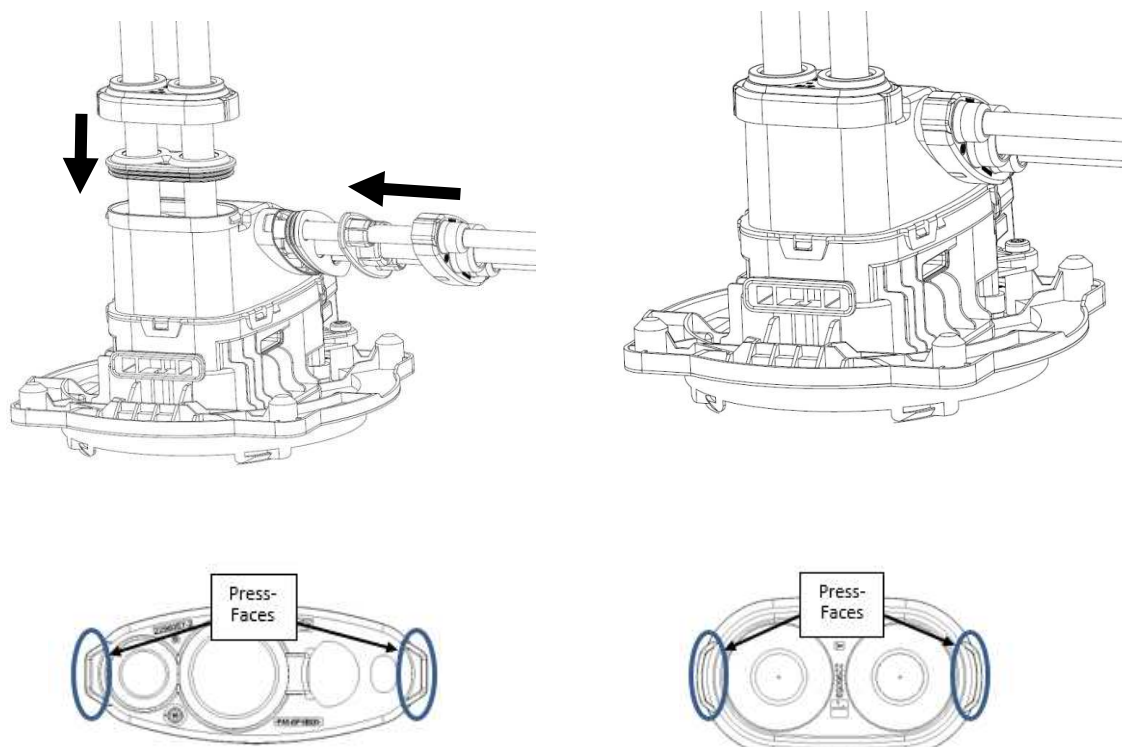

**Figure 44a**
**Step 13**

Move the STRAIN RELIEF AC [POS. 7] together with FAMILY SEAL AC [POS. 6] into their position in the CABLE EXIT [POS. 5]. Ensure that all wires (AC-Multicore, PE-Single wire, LV-wires) are well positioned in the FAMILY SEAL, so that the seal lips are placed on the outer isolation of the cables

Ensure that the mark from Step 2 is on the same Level to the End of the CABLE EXIT [Pos. 5].

Push the COVER CABLE SEAL AC [POS. 8] over it and snap it on the CABLE EXIT [Pos. 5]. Ensure that both hooks are properly engaged. Typical press-on-force = 250N; max. press-on-force = 500N.

Move the FAMILY SEAL DC [Pos.10] into the CABLE EXIT [Pos. 5] and snap the COVER CABLE SEAL DC [Pos. 9] over CABLE EXIT COVER [Pos. 5]. Ensure that both hooks are properly engaged. Typical press-on-force = 250N; max. press-on-force = 500N.

**Figure 45**

Place a cable tie (proposed dimensions 2,5mm wide, material to be heat stabilized and suitable for automotive use) around the single wire signal cables and the bridge next to the Cover Cable Seal [Pos. 8] and pull tight (Positioning see figure 46).

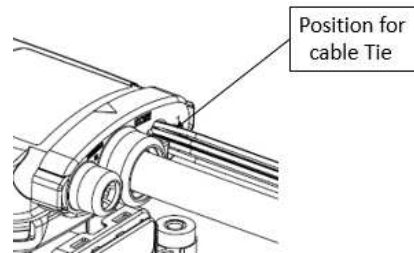

**Figure 46**

**Step 14**

Assemble Protection Cap [Pos. 13] at Inlet Housing [Pos. 1] as shown in the Figure 47  
 Typical press-on-force = 10N; max. press-on-force = 100N.

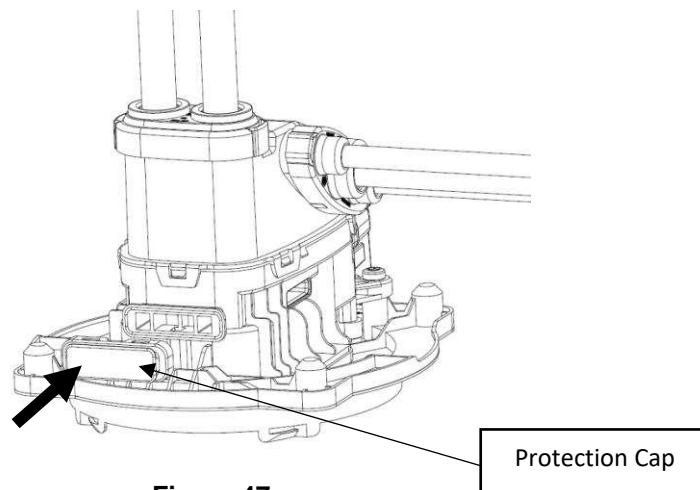

**Figure 47**

**Step 15**

Thread the service unlock ball wire through the hole in the actuator housing.

Snap the ball into the seating of the red unlocking strap as shown in the figure 48. Typical press-in-force = 10N; max. press-in-force = 50N.

Ensure that the ball is fixed well by pulling and pushing at the wire with a low force.

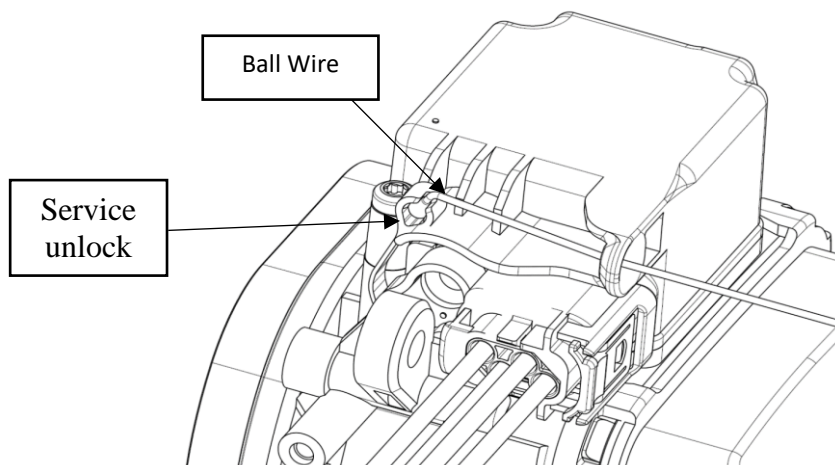
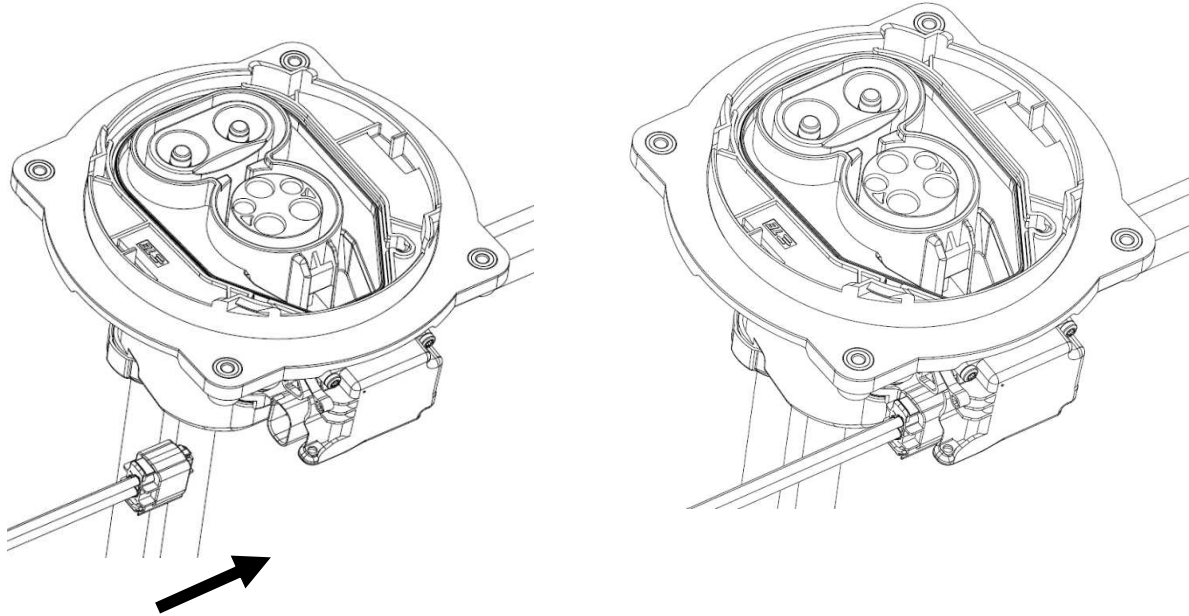

**Figure 48**



**Step 16**

Assemble the Connector for the Actuator connection acc. to application spec of MQS-Connector. (Applicator 2151038; Die Set 5-1579001-1).  
Push connector on actuator housing. To ensure that the connector is correctly inserted, pull and push with a low force on the housing (max. 10N).

**Figure 49****Step 17**

Apply a label on specified face of CABLE EXIT. The label needs to include information acc. requirements of IEC62196-x / SAE J1772. Also information acc. to customer requirements can be applied here.

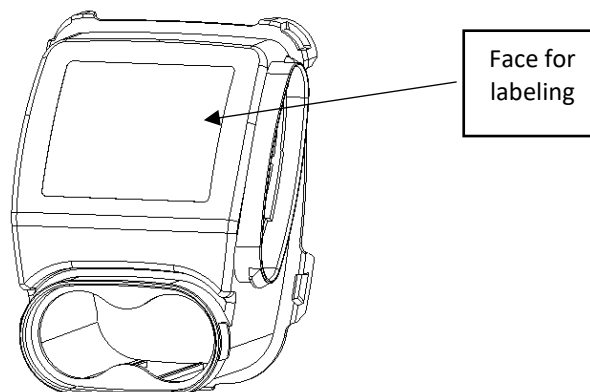
**Figure 50**

## 6.6. End of Line Test



The assembled Charge Inlet has to be tested electrically and mechanically to applicable requirements, including High Voltage test.

As a minimum the following tests have to be performed:

- Isolation resistance:  
TEST VOLTAGE: 1000VDC  
Inspection Duration: 1s  
min. Riso: 200MΩ  
AC versus AC; AC versus multicore shield, DC+ versus DC-; DC versus DC shield
- Dielectric withstand voltage:  
TEST VOLTAGE: 1500VAC  
Inspection duration: 1s  
max. leakage current: 10mA  
AC versus AC; AC versus multicore shield, DC+ versus DC-; DC versus DC shield
- Correct pinning
- Check seals for correct seating / Check of leakage
- Gauge check of geometrical interface acc. IEC 62196-3
- Functionality of connector locking device (mechanical check of pin movement in locking and unlocking position)

## 6.7. Technical Cleanliness Charge Inlet Assembled

According to risk assessments performed by TE Connectivity the following CCC for metallic particles at the complete assembled charge inlet (valid until cable outlet) are defined:

N (H40/I6/J2/K0)

LTR	REVISION RECORD	DWN	APP	DATE
A	FIRST REVISION FOR COMBO I	ARAVIND H.M	F. WITTROCK	11SEP2017
A1	TABLE 1, FIGURE 6. REWORKED	M. SCHMIDT	F. WITTROCK	13OCT2017
A2	ESD-SAFETY INFORMATION ADDED; RADIAL SEAL P/N CHANGED; PRESS FORCES DEFINED	M. SCHMIDT	F. WITTROCK	16APR2018
A3	- GEN.4 VARIANTS AND 40A VARIANT ADDED; CABLE EXIT 20° AC W/O CRIMPRING - PAGE 6 & 16, FERRULE 2316553-2 FOR NEW APPLICATIONS ADDED - TABLE 2 POS.6, 2296039-3 WAS 2296039-1 (REPL.) - TABLE 2 POS 6, 2296039-4 WAS 2296039-2 (REPL.)	R. SCHWAN	F. WITTROCK	18JAN2019
A4	-SPECIFICATION REVISED -TABLE 1, ALL 6MM <sup>2</sup> CONTACTS NEW CH 3.7 -TABLE 1, CONTACT 2293267-3 REMOVED -TABLE 1, FERRULE 2316553-2 REMOVED -ALTERNATIVE TAPE PROTECTION FIG.14B ADDED -ALTERNATIVE TAPE PROTECTION FIG.21B ADDED -STEP 12 CABLE TIE AND FIG 41D ADDED -FIG.28 TOLERANCE WAS +1/-0 -TABLE 50MM <sup>2</sup> , DIM.A WAS 23,5 -TABLE 50MM <sup>2</sup> , DIM.B WAS 30.5	R. SCHWAN	F. WITTROCK	21MAY2019
B	-TABLE 1, FERRULE 2316553-2 WAS 2316553-1 -TABLE 1, APPLICATOR 8-528041-2 WAS 3-528041-8 -TABLE 1/-10, FERRULE CH 15,3 +/-0,1 WAS 15,8 +/-0,2 -TABLE 2, FERRULE 2316553-2 WAS 2316553-1 -ASSY STEP 5B, "BRAID NOT COMBED OUT" ADDED	R. SCHWAN	F. WITTROCK	06SEP2019
C	-2.1.A LIST OF COMPONENTS CHANGED TO CUSTOMER DRAWING -3.4 NOTE REGARDING PVC INSULATION ADDED -TABLE1, RECOMMENDED HV20 ADDED -TABLE 2, BOM CHANGED TO COMPONENT DESCRIPTION -6.3 PARTS TO ORDER REFERED TO CUSTOMER DRAWING -6.5 STEP2, RECOMMENDATIONS OF MARKING ADDED -FIGURE15, DIM"C" ADDED -TABLE3, DIM "C" TOLERANCE ADDED -FIGURE16, DIM"E" ADDED -TABLE4, DIM"E" 106 WAS 96, TOLERANCE ADDED - FIGURE18, DIM"B" ADDED -TABLE5, DIM"B" 94REF WAS 95 -FIGURE20, DIM"B" ADDED -TABLE6, DIM"B" 80REF AND 70REF WERE 80 -FIGURE23, DIM"C" ADDED -FIGURE24, DIM"E" ADDED -FIGURE27, DIM"C" ADDED -FIGURE34, DIM"C" ADDED -TABLE11, 61REF WAS 58 -STEP5C, PROCESSING WITH OUTER FERRULE ALLOWED	R. SCHWAN	F. WITTROCK	16DEZ2019

C1	-TABLE 1, CONTACT 2-2293266-3, 2-2292541-4 AND 2-2293267-4 ADDED; APPLICATOR 2234183-1 ADDED -FIGURE13, NOTE "CARDBOARD PACKAGING OF THE INLET HSG (POS. 1) ARE ONLY TO BE OPENED IN ESD PROTECTED AREAS." ADDED -TABLE 10, IMAGE OF CRIMPED FERRULE ADDED -6.6 ISOLATION RESISTANCE, "AC VERSUS AC; AC VERSUS MULTICORE SHIELD, DC+ VERSUS DC-; DC VERSUS DC SHIELD" ADDED -6.6 DIELECTRIC WITHSTAND VOLTAGE, -TEST VOLTAGE: 1500VAC WAS 2000VAC -"AC VERSUS AC; AC VERSUS MULTICORE SHIELD, DC+ VERSUS DC-; DC VERSUS DC SHIELD" ADDED	R. SCHWAN	F. WITTROCK	18JUN2020
C2	-2.1 B): 114-13000 IN LIST ADDED -TABLE2: POS.2 SPEC AND SMBT REQUIREMENT ADDED, POS.15 SPEC. ADDED -STEP4: IMAGE PRESENTATION OF PINNING MNL UPDATED -STEP5B: CRIMPING SEQUENCE PIN [POS12] AND FERRULE [POS16] CORRECTED -STEP5B: VIEWS OF BUCKLED FERRULE ADDED	R. SCHWAN	F. WITTROCK	16OCT2020
D	-TABLE 1, CONTACT 2-2293267-4 CHANGED TO NEW DIE SET WITH CRIMP GEOMETRY 2B, APPLICATOR NO. 2388610-1 AND CRIMP HIGHT 4.90±0.1. CONTACT 2293266-3, 2292541-4 AND 2293267-4 DELETED FROM TABLE.	M. SCHMIDT	F. WITTROCK	15APRIL2021
D1	-2.1) KIT NUMBER UPDATED -4) APPLICATOR PN UPDATED -6.1) FIGURE 10 UPDATED -6.1) FOOTNOTE ADDED	M. MAENCHE	M. SCHMIDT	29APRIL2022
D2	-3.4) ALTERNATIVE PE-WIRE ADDED -4) APPLICATOR NOTE ADDED	M. MAENCHE	M. SCHMIDT	31AUG2022
D3	-4) APPLICATOR UPDATED -6.5) UPDATED WIRE LENGTH -6.7) TECHNICAL CLEANLINESS ADDED	M. MAENCHE	M. SCHMIDT	06DEC2022
D4	-4) TABLE 1, NEW VARIANT ADDED	B. GOKULA	J. PALAS	24APR2024
D5	-STEP 12 MODIFIED FOR CHANGE IN CABLE EXIT ASSEMBLY PROCEDURE.	B. GOKULA	J. PALAS	18FEB2025

DR ARAVIND H.M 11SEP2017	TE CONNECTIVITY GERMANY GMBH AMPÈRESTRASSE 12-14 D-64625 BENSHEIM GERMANY		
CHK M. SCHMIDT 11SEP2017			
APP F. WITTROCK 11SEP2017	NO 114-94438	REV D5	LOC AI
TITLE	Vehicle Charge Inlet CCS 1 acc. IEC62196-3, CONFIGURATION EE		