



Door Zone Module - Connector Series



TABLE OF CONTENTS

1 GENERAL

1.1 PURPOSE

1.2 CUSTOMER DRAWINGS

1.3 DELIVERY CONDITION

1.3.1 14 WAY HYBRID FEMALE CONNECTOR

1.3.2 24 WAY GEN Y FEMALE CONNECTOR

1.3.3 24 WAY HYBRID FEMALE CONNECTOR

1.3.4 22 WAY GEN Y FEMALE CONNECTOR

1.3.5 22 WAY GEN Y FEMALE CONNECTOR (WITHOUT WIRE COVER OPTION)

1.3.6 24 WAY HYBRID FEMALE CONNECTOR (WITHOUT WIRE COVER OPTION)

1.3.7 20 WAY GEN Y FEMALE CONNECTOR (WITHOUT WIRE COVER OPTION)

1.4 APPLICABLE COMPONENTS

1.4.1 APPLICABLE COMPONENTS – 14 WAY HYBRID FEMALE CONNECTOR

1.4.2 APPLICABLE COMPONENTS – 24 WAY GEN Y FEMALE CONNECTOR

1.4.3 APPLICABLE COMPONENTS – 24 WAY HYBRID FEMALE CONNECTOR

1.4.4 APPLICABLE COMPONENTS – 22 WAY GEN Y FEMALE CONNECTOR

*1.4.5 APPLICABLE COMPONENTS – 22 WAY GEN Y FEMALE CONNECTOR
(WITHOUT WIRE COVER OPTION)*

*1.4.6 APPLICABLE COMPONENTS – 24 WAY HYBRID FEMALE CONNECTOR
(WITHOUT WIRE COVER OPTION)*

*1.4.7 APPLICABLE COMPONENTS – 20 WAY GEN Y FEMALE CONNECTOR
(WITHOUT WIRE COVER OPTION)*

2 ASSEMBLY OF COMPONENTS (EXEMPLARY)

2.1 ASSEMBLY OF TERMINALS

2.1.1 INSERTION OF GEN Y TERMINALS TO THE CONNECTOR HOUSING

2.1.2 INSERTION OF MCP 2.8 TERMINALS TO THE CONNECTOR HOUSING

2.1.3 MOVING SPACER INTO END-LOCK POSITION

2.2 ASSEMBLY OF WIRE COVER

2.3 ASSEMBLY TO INTERFACE

3 DISASSEMBLY OF COMPONENTS (EXEMPLARY)

3.4 REMOVING THE CONNECTOR FROM INTERFACE

3.5 REMOVING THE SPACER FROM THE CONNECTOR

3.6 REMOVAL OF TERMINALS

2.6.1 REMOVAL OF MCP 2.8 TERMINALS

2.6.2 REMOVAL OF GEN Y TERMINALS

1 GENERAL

1.1 PURPOSE

THIS SPECIFICATION DESCRIBES HOW TO HANDLE THE “JLR DOOR ZONE MODULE CONNECTOR SERIES” - COMPONENTS.

1.2 CUSTOMER DRAWINGS

THIS APPLICATION SPECIFICATION IS BASED ON THE LATEST VALID CUSTOMER DRAWINGS.

14 Way Hybrid Female Connector System

C2306914 14 Way Hybrid Female Connector Assembly

C2306917 14 Way Wire Cover

24 Way Gen. Y Female Connector System

C2306908 24 Way Female Connector Assembly

C2306911 22/24 Way Wire Cover

24 Way Hybrid Female Connector System

C2330142 24 Way Hybrid Female Connector Assembly

C2330144 24 Way Wire Cover

22 Way Gen. Y Female Connector System

C2330140 22 Way Female Connector Assembly

C2306911 22/24 Way Wire Cover

22 Way Gen. Y Female Connector System (without wire cover option)

C2208021 22 Way Female Connector Assembly

24 Way Hybrid Female Connector System (without wire cover option)

C2236269 24 Way Hybrid Female Connector Assembly

20 Way Gen. Y Female Connector System (without wire cover option)



C2236266 20 Way Gen Y Female Connector Assembly

1.3 DELIVERY CONDITIONS

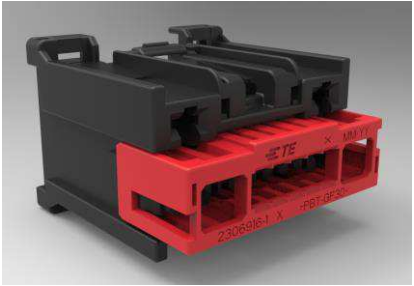

1.3.1 14 Way Hybrid Female Connector

<p>14 Way Hybrid Female Connector Assembly</p>	<p>TE-PNs: 0-2306914-1 0-2306914-2 0-2306914-3 1-2306914-1 1-2306914-2 1-2306914-3</p>	
<p>14 Way Hybrid Wire Cover</p>	<p>TE-PNs: 2306917-1 2306917-2 2306917-3</p>	

1.3.2 24 Way Gen Y Female Connector

<p>24 Way Gen Y Female Connector Assembly</p>	<p>TE-PNs: 0-2306908-1 1-2306908-1</p>	
<p>22/24 Way Wire Cover</p>	<p>TE-PN: 2306911-1 2306911-2</p>	

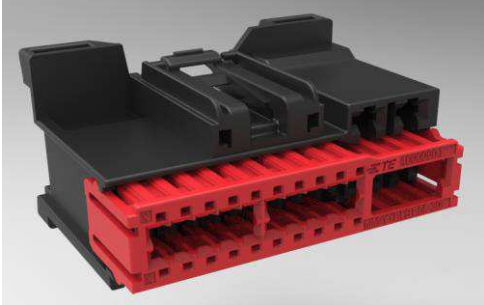
1.3.3 24 Way Hybrid Female Connector

<p>24 Way Hybrid Female Connector System Assembly</p>	<p>TE-PNs: 0-2330142-1 0-2330142-2 0-2330142-3 1-2330142-1 1-2330142-2 1-2330142-3</p>	
<p>24 Way Wire Cover</p>	<p>TE-PNs: 2330144-1 2330144-2</p>	

1.3.4 22 Way Gen Y Female Connector

<p>22 Way Gen Y Female Connector Assembly</p>	<p>TE-PNs: 2330140-1</p>	
<p>22/24 Way Wire Cover</p>	<p>TE-PN: 2306911-1</p>	

1.3.5 22 Way Gen Y Female Connector (*without wire cover option*)

<p>22 Way Gen Y Female Connector Assembly</p>	<p>TE-PNs: 0-2208021-1 0-2208021-2 0-2208021-3 0-2208021-4</p>	
---	---	--

1.3.6 24 Way Hybrid Connector (*without wire cover option*)

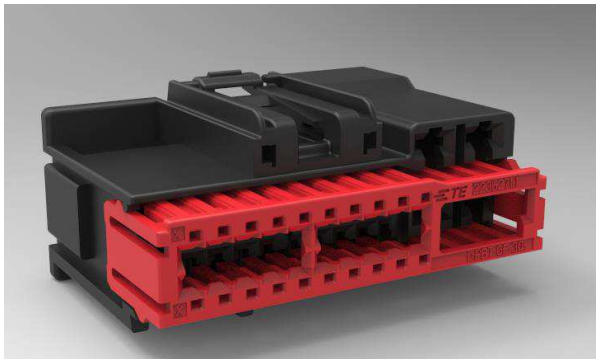
<p>24 Way Hybrid Female Connector Assembly</p>	<p>TE-PNs: 0-2236269-1 0-2236269-2 0-2236269-3 1-2236269-1 1-2236269-2 1-2236269-3</p>	
--	---	--

1.3.7 20 Way Gen Y Female Connector (*without wire cover option*)

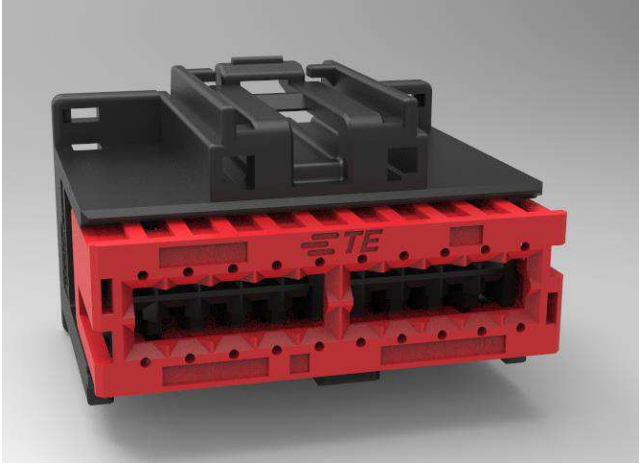

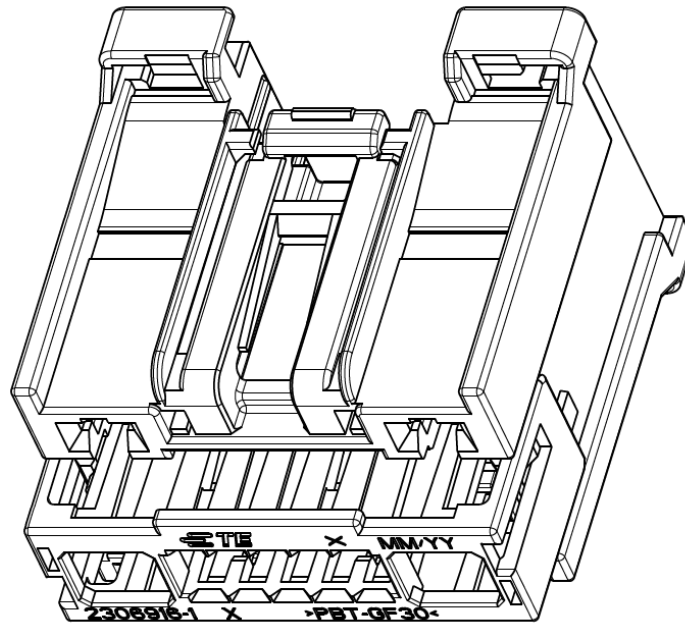

<p>20 Way Gen Y Female Connector Assembly</p>	<p>TE-PNs: 0-2236266-1 0-2236266-2 1-2236269-1 1-2236269-2</p>	
---	---	--

1.4 APPLICABLE COMPONENTS

1.4.1 APPLICABLE COMPONENTS - 14 Way Hybrid Female Connector



*V MAX TEMPERATURE = MAX TEMPERATURE RISE + MAX ENVIROMENTAL TEMPERATURE



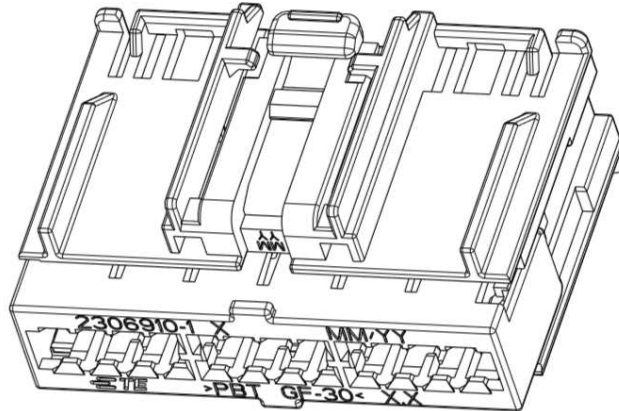

APPLICABLE COMPONENTS					
ITEM	DESCRIPTION	COLOUR/ PLATING	JLR COMPONENT PART NO.	SUPPLIER COMPONENT PART NO.	*V MAX. TEMPERATURE
1	0.64 GENERATION Y UNSEALED FEMALE TERMINAL (0.13mm ²)	TIN	CHCT-14474-MJA	0-2035334-5	100°C
	0.64 GENERATION Y UNSEALED FEMALE TERMINAL (0.35-0.5mm ²) 	TIN	CHCT-14474-MEA	0-2035334-1	100°C
	0.64 GENERATION Y UNSEALED FEMALE TERMINAL (0.75mm ²)	TIN	CHCT-14474-LKA	0-2035334-2	100°C
	0.64 GENERATION Y UNSEALED FEMALE TERMINAL (0.35-0.5mm ²) 	TIN	 CHCT-14474-MGA	0-2035334-3	100°C
	0.64 GENERATION Y UNSEALED FEMALE TERMINAL (0.75mm ²)	TIN	 CHCT-14474-MHA	0-2035334-4	100°C
2	MCP 2.8 LANCELESS FEMALE TERMINAL (1.0-2.5mm ²)	TIN	2S6T-14474-CA	1-1355877-1	130°C
	MCP 2.8 LANCELESS FEMALE TERMINAL (2.5-4.0mm ²)	TIN	2S6T-14474-DA	1-1355880-1	130°C

1.4.2 APPLICABLE COMPONENTS – 24 Way Gen Y Female Connector



*V MAX TEMPERATURE = MAX TEMPERATURE RISE + MAX ENVIROMENTAL TEMPERATURE



APPLICABLE COMPONENTS

ITEM	DESCRIPTION	COLOUR/ PLATING	JLR COMPONENT PART NO.	SUPPLIER COMPONENT PART NO.	*V MAX. TEMPERATURE
1	0.64 GENERATION Y UNSEALED FEMALE TERMINAL (0.13mm ²)	TIN	CHCT-14474-MJA	0-2035334-5	100°C
	0.64 GENERATION Y UNSEALED FEMALE TERMINAL (0.35-0.5mm ²) 	TIN	CHCT-14474-MEA	0-2035334-1	100°C
	0.64 GENERATION Y UNSEALED FEMALE TERMINAL (0.75mm ²)	TIN	CHCT-14474-LKA	0-2035334-2	100°C
	0.64 GENERATION Y UNSEALED FEMALE TERMINAL (0.35-0.5mm ²) 	TIN	 CHCT-14474-MGA	0-2035334-3	100°C
	0.64 GENERATION Y UNSEALED FEMALE TERMINAL (0.75mm ²)	TIN	 CHCT-14474-MHA	0-2035334-4	100°C

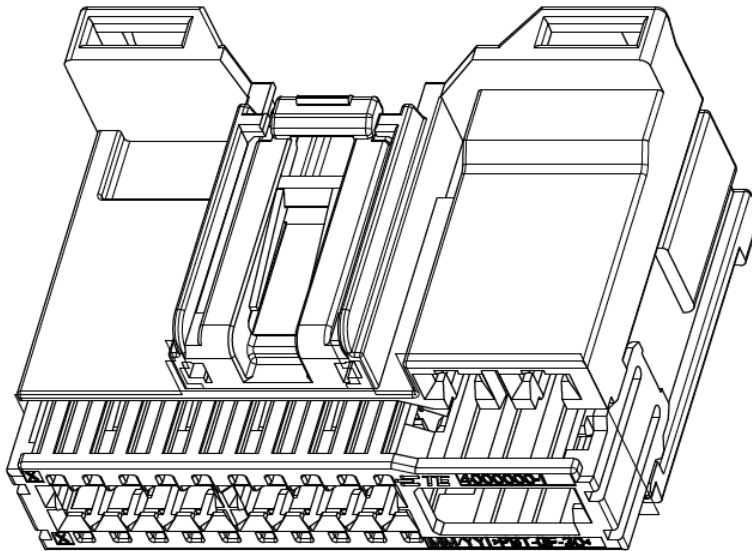
1.4.3 APPLICABLE COMPONENTS – 24 Way Hybrid Female Connector



*V MAX TEMPERATURE = MAX TEMPERATURE RISE + MAX ENVIRONMENTAL TEMPERATURE

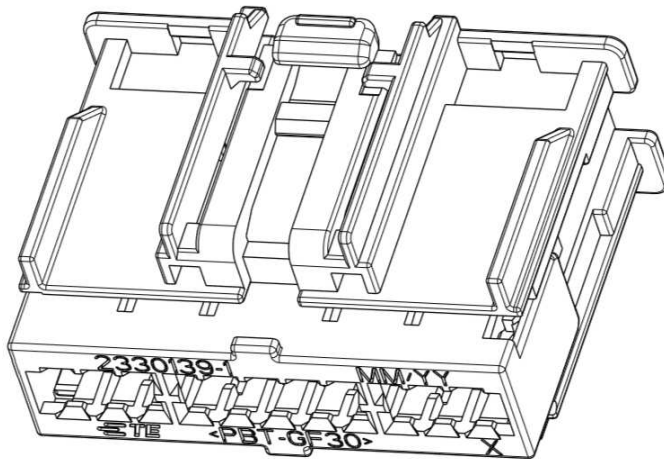

APPLICABLE COMPONENTS					
ITEM	DESCRIPTION	COLOUR/ PLATING	JLR COMPONENT PART NO.	SUPPLIER COMPONENT PART NO.	*V MAX. TEMPERATURE
1	0.64 GENERATION Y UNSEALED FEMALE TERMINAL (0.13mm ²)	TIN	CHCT-14474-MJA	0-2035334-5	100°C
	0.64 GENERATION Y UNSEALED FEMALE TERMINAL (0.35-0.5mm ²) 	TIN	CHCT-14474-MEA	0-2035334-1	100°C
	0.64 GENERATION Y UNSEALED FEMALE TERMINAL (0.75mm ²)	TIN	CHCT-14474-LKA	0-2035334-2	100°C
	0.64 GENERATION Y UNSEALED FEMALE TERMINAL (0.35-0.5mm ²) 	TIN	CHCT-14474-MGA	0-2035334-3	100°C
	0.64 GENERATION Y UNSEALED FEMALE TERMINAL (0.75mm ²)	TIN	CHCT-14474-MHA	0-2035334-4	100°C
2	MCP 2.8 LANCELESS FEMALE TERMINAL (1.0-2.5mm ²)	TIN	2S6T-14474-CA	1-1355877-1	130°C
	MCP 2.8 LANCELESS FEMALE TERMINAL (2.5-4.0mm ²)	TIN	2S6T-14474-DA	1-1355880-1	130°C

1.4.4 APPLICABLE COMPONENTS – 22 Way Gen Y Female Connector



*V MAX TEMPERATURE = MAX TEMPERATURE RISE + MAX ENVIROMENTAL TEMPERATURE

APPLICABLE COMPONENTS

ITEM	DESCRIPTION	COLOUR/ PLATING	JLR COMPONENT PART NO.	SUPPLIER COMPONENT PART NO.	*V MAX. TEMPERATURE
1	0.64 GENERATION Y UNSEALED FEMALE TERMINAL (0.13mm ²)	TIN	CHCT-14474-MJA	0-2035334-5	100°C
	0.64 GENERATION Y UNSEALED FEMALE TERMINAL (0.35-0.5mm ²) 	TIN	CHCT-14474-MEA	0-2035334-1	100°C
	0.64 GENERATION Y UNSEALED FEMALE TERMINAL (0.75mm ²)	TIN	CHCT-14474-LKA	0-2035334-2	100°C
	0.64 GENERATION Y UNSEALED FEMALE TERMINAL (0.35-0.5mm ²) 	TIN	CHCT-14474-MGA	0-2035334-3	100°C
	0.64 GENERATION Y UNSEALED FEMALE TERMINAL (0.75mm ²)	TIN	CHCT-14474-MHA	0-2035334-4	100°C

1.4.5 APPLICABLE COMPONENTS – 22 Way Gen Y Female Connector

NOTE: WITHOUT WIRE COVER OPTION!

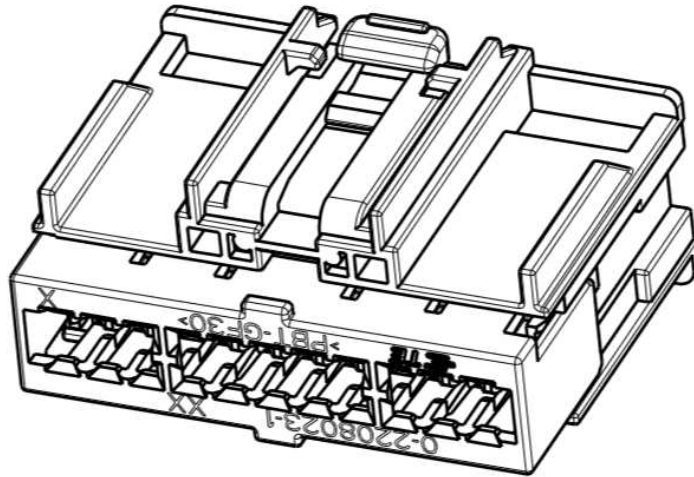

APPLICABLE COMPONENTS

ITEM	DESCRIPTION	COLOUR/ PLATING	JLR COMPONENT PART NO.	SUPPLIER COMPONENT PART NO.	*V MAX. TEMPERATURE
1	0.64 GENERATION Y UNSEALED FEMALE TERMINAL, J-HOOK DESIGN (0.13mm ²)	TIN PLATE	TBD	0-2035334-5	105°C
	0.64 GENERATION Y UNSEALED FEMALE TERMINAL, J-HOOK DESIGN (0.35-0.5mm ²)	TIN PLATE	TBD	0-2035334-1	105°C
	0.64 GENERATION Y UNSEALED FEMALE TERMINAL, J-HOOK DESIGN (0.75mm ²)	TIN PLATE	TBD	0-2035334-2	105°C

1.4.6 APPLICABLE COMPONENTS – 24 Way Hybrid Female Connector

NOTE: WITHOUT WIRE COVER OPTION!

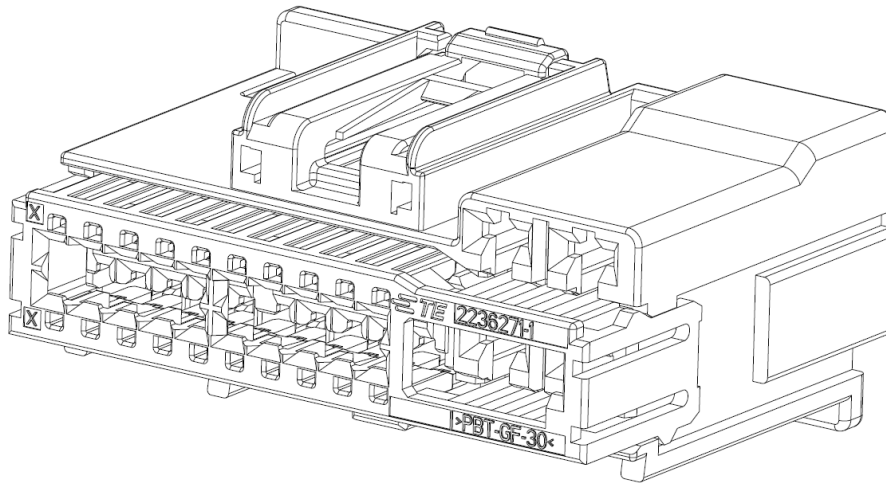

APPLICABLE TERMINALS		
0.64 GENERATION Y UNSEALED FEMALE TERMINAL (0.13mm ²)	TIN	0-2035334-5
0.64 GENERATION Y UNSEALED FEMALE TERMINAL (0.35mm ² -0.50mm ²)	TIN	0-2035334-1
0.64 GENERATION Y UNSEALED FEMALE TERMINAL (0.75mm ²)	TIN	0-2035334-2
MCP 2.8 LANCELESS FEMALE TERMINAL (1.0mm ² -2.50mm ²)	TIN	1-1355877-1
MCP 2.8 LANCELESS FEMALE TERMINAL (2.5mm ² -4.0mm ²)	TIN	1-1355880-1
DESCRIPTION	PLATING COLOUR	TE CONNECTIVITY COMP. PART NO:

1.4.7 APPLICABLE COMPONENTS – 20 Way Gen Y Female Connector

NOTE: WITHOUT WIRE COVER OPTION!

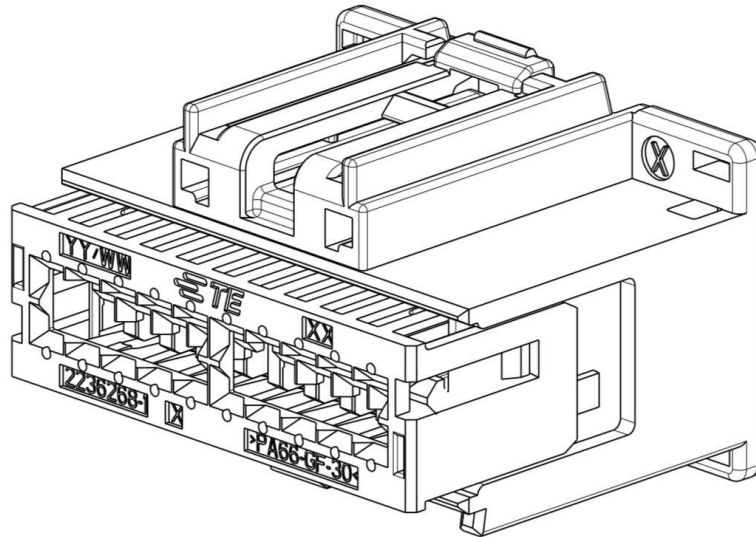

APPLICABLE COMPONENTS							
ITEM	DESCRIPTION	MANDATORY (YES/NO)	TERMINAL CAVITY MAX OD	COLOUR/PLATING	JLR COMP. PART NO.	SUPPLIER COMP. PART NO.	MAX. TEMP.
1	0.64 GENERATION Y UNSELAED FEMALE TERMINAL (0.75mm ²)	NO	Ø2.15	TIN PLATE	CHCT-14474-LKA	0-2035334-2	100°C
	0.64 GENERATION Y UNSELAED FEMALE TERMINAL (0.35-0.50mm ²) 	NO	Ø1.97	TIN PLATE	CHCT-14474-MEA	0-2035334-1	100°C
	0.64 GENERATION Y UNSELAED FEMALE TERMINAL (0.13mm ²)	NO	Ø1.29	TIN PLATE	CHCT-14474-MJA	0-2035334-5	100°C

2. ASSEMBLY OF COMPONENTS (EXEMPLARY)

2.1 ASSEMBLY OF TERMINALS

Make sure that the delivered connector assembly is in pre-lock position (1).
 If the Connector's TPA is set in end-lock position (2) you will not be able to insert the contacts into the connector cavities!

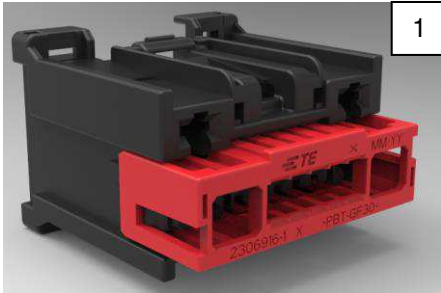

2.1.1 INSERTION OF GEN. Y CONTACTS TO THE CONNECTOR HOUSING

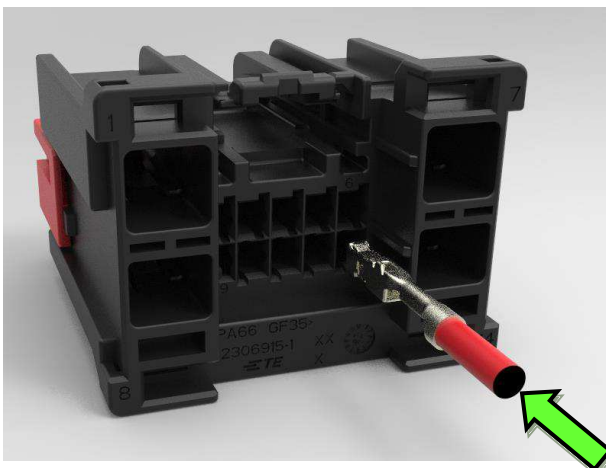

NOTE:

INSERT TERMINALS STRAIGHT INTO CAVITIES UNTIL "CLICK".
 PULL THE WIRE TO CONFIRM THAT THE TERMINAL IS RESTRAINED BY
 PRIMARY LOCK.

2.1.2 INSERTION OF MCP 2.8 CONTACTS TO THE CONNECTOR HOUSING

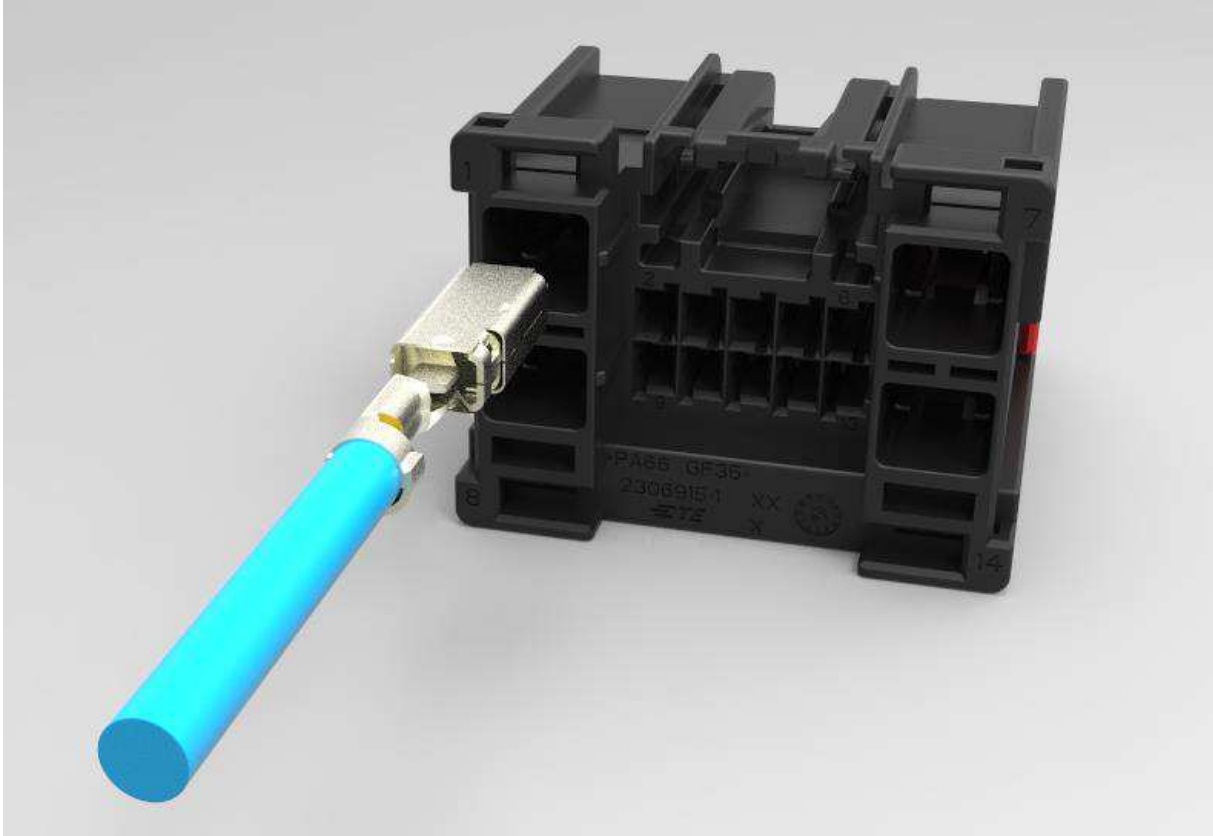

NOTE: INSERT TERMINALS STRAIGHT INTO CAVITIES UNTIL “CLICK”.
PULL THE WIRE TO CONFIRM THAT THE TERMINAL IS RETAINED BY
PRIMARY LOCK.

2.1.3 MOVING TPA INTO END-LOCK POSITION

After assembly of all Terminals make sure that the TPA will be pushed from pre-lock to end-lock position

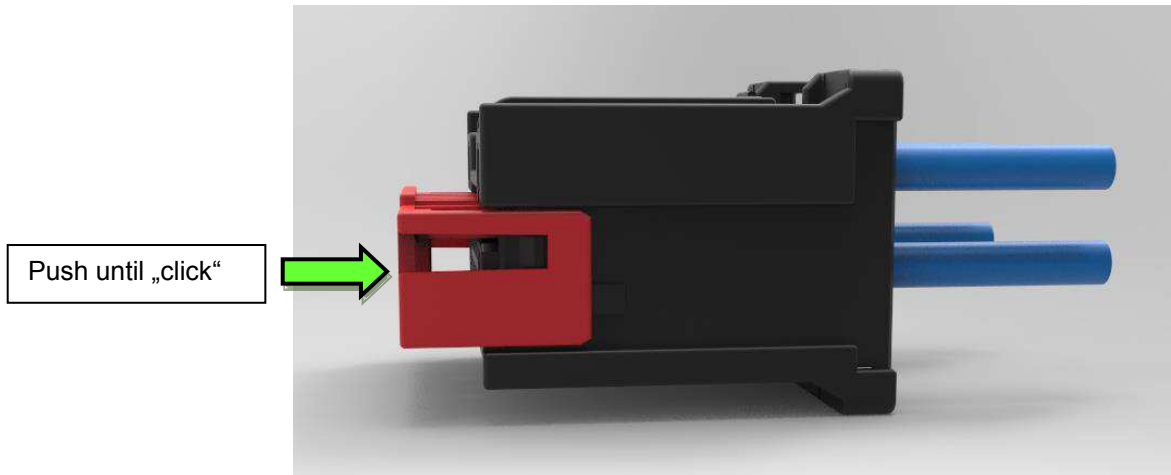

Correctly assembled connector with TPA in end-lock position

2.2 ASSEMBLY OF WIRE COVER

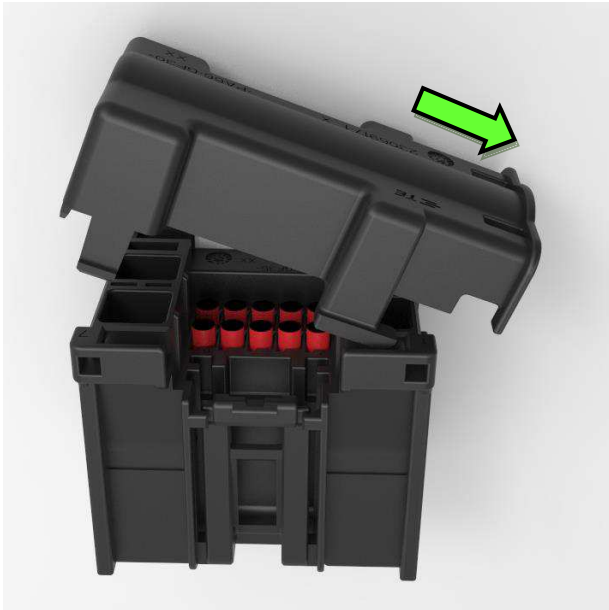

- Make sure that you put the hooks into the slots on the top of the connector
- Press the cover onto the connector so that the locking elements click into place.

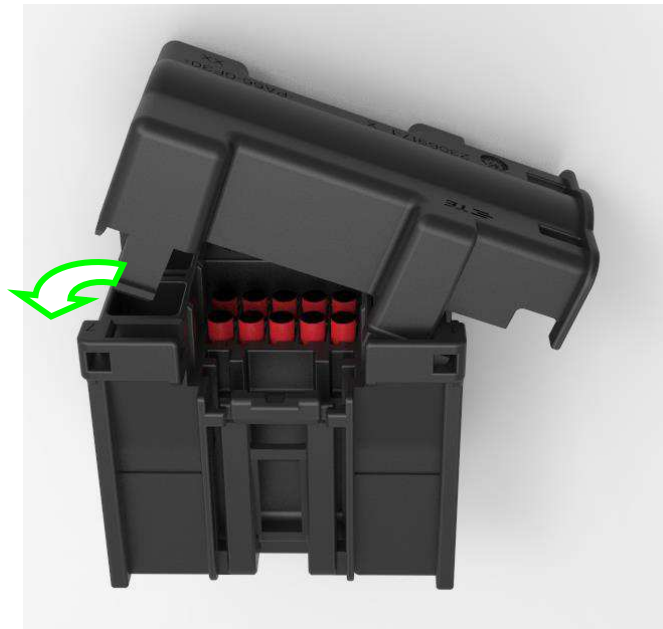

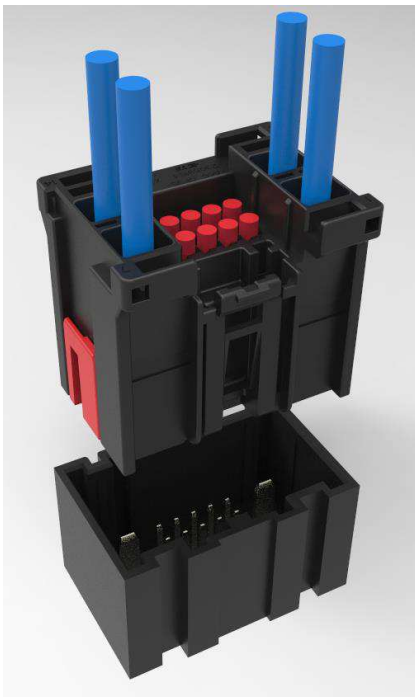
2.3 ASSEMBLY TO INTERFACE

Position the Connector above the Interface and push it downwards until the latch of the connector clicks into the interface.

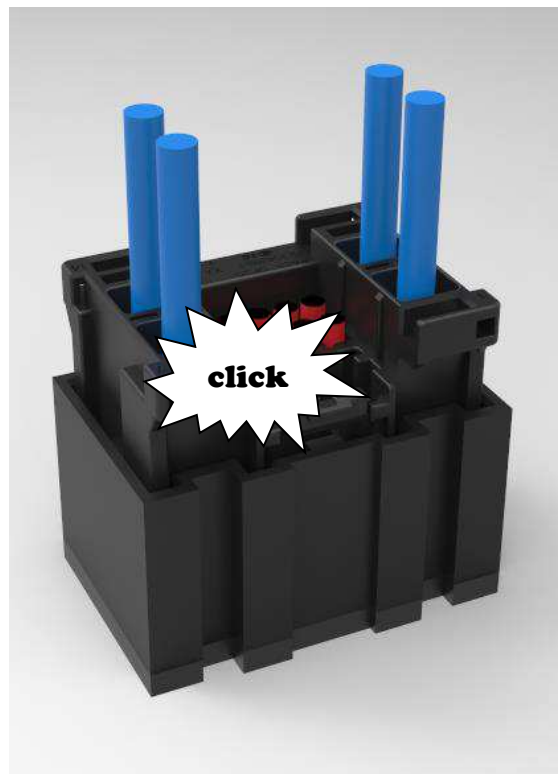

NOTE: *CONNECTOR SHOWN WITHOUT WIRE COVER*

3. DISASSEMBLY OF COMPONENTS (EXEMPLARY)

3.1 REMOVING THE CONNECTOR FROM INTERFACE

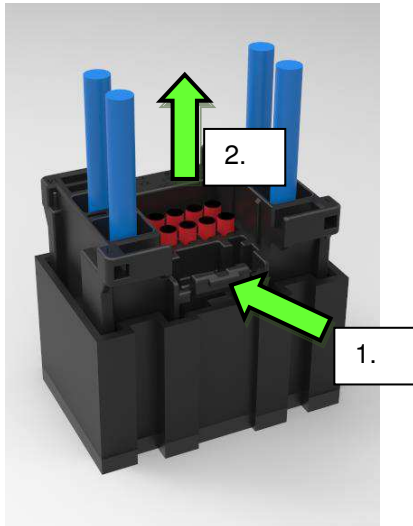

1. Push the connector latch to release the connector and then while doing this
2. pull it upwards out of the Interface.

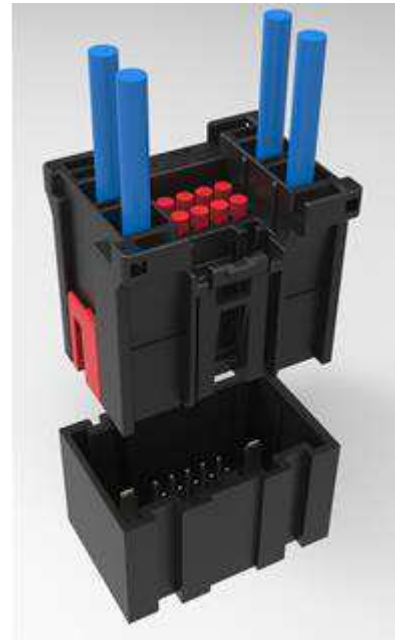

3.2 REMOVAL OF THE WIRE COVER

1. Press the two surfaces (highlighted in green) into the direction shown by the arrows with your fingers and lift the Wire Cover upwards

2. Now you can just remove the wire cover in the direction shown.

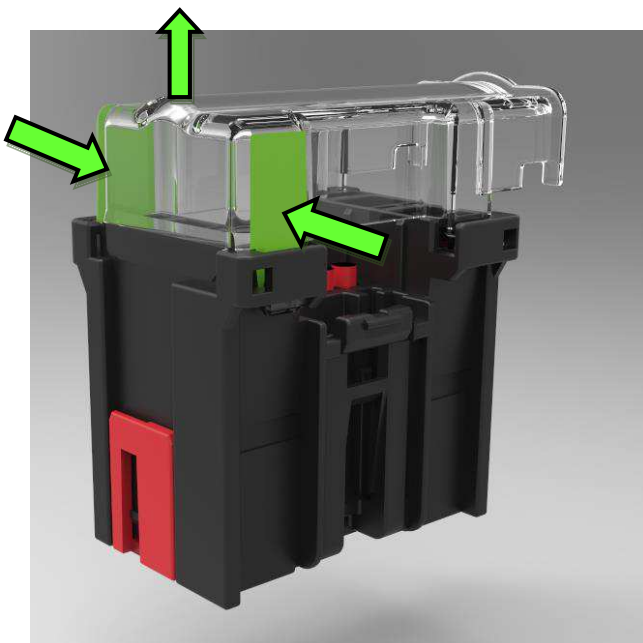

NOTE: WIRE COVER PICTURED TRANSPARENT FOR BETTER VISIBILITY

3.3 TPA REMOVAL

Deflect the latches of the spacer like shown in the picture...



...and lift it up from the connector.



3.4 REMOVAL OF TERMINALS

3.4.1 REMOVAL OF MCP 2.8 TERMINALS

For a save removal procedure please use Extraction Tool 1452426-1 only.



Insert the extraction tool as pictured into the connector housing.

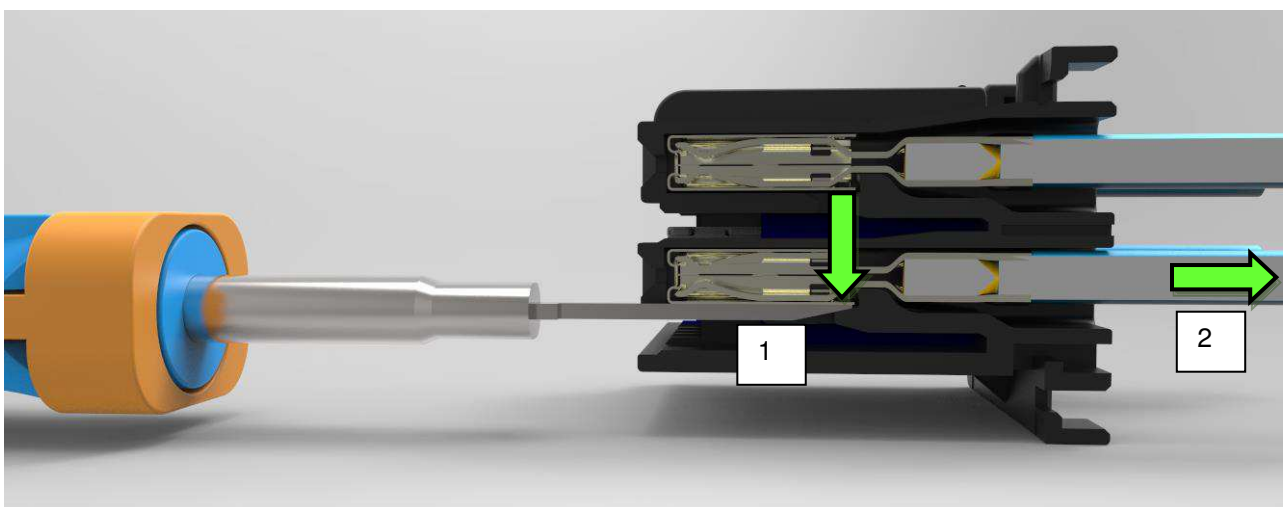
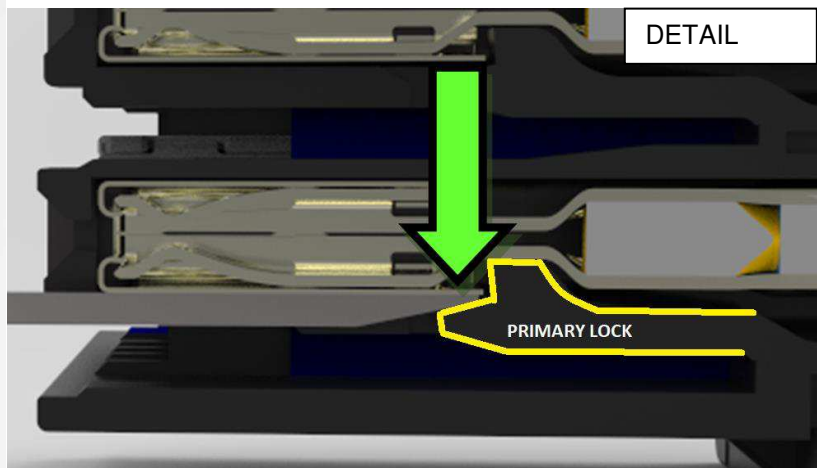

Deflect the primary lock with the extraction tool (1) and then pull the contact by the wire out of the cavity (2).

3.4.2 REMOVAL OF GEN Y TERMINALS

Please use an extraction tool as specified in the Gen Y Application Spec 114-13183:

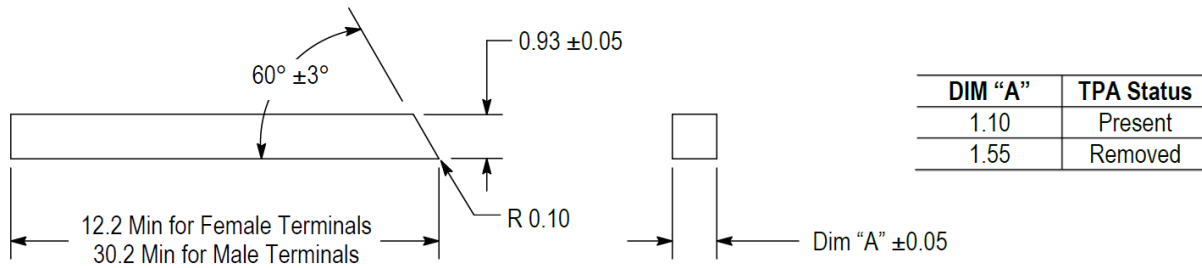

Insert Extraction tool into the contact cavity and deflect the primary lock while pulling the wire to extract the contact. See pictures below:

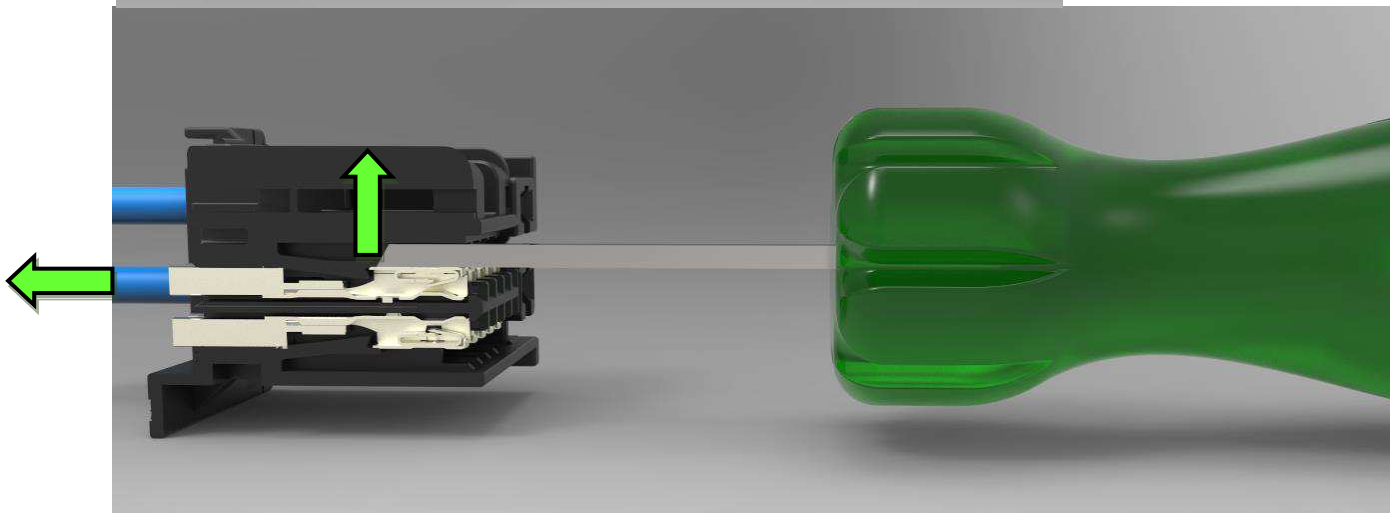
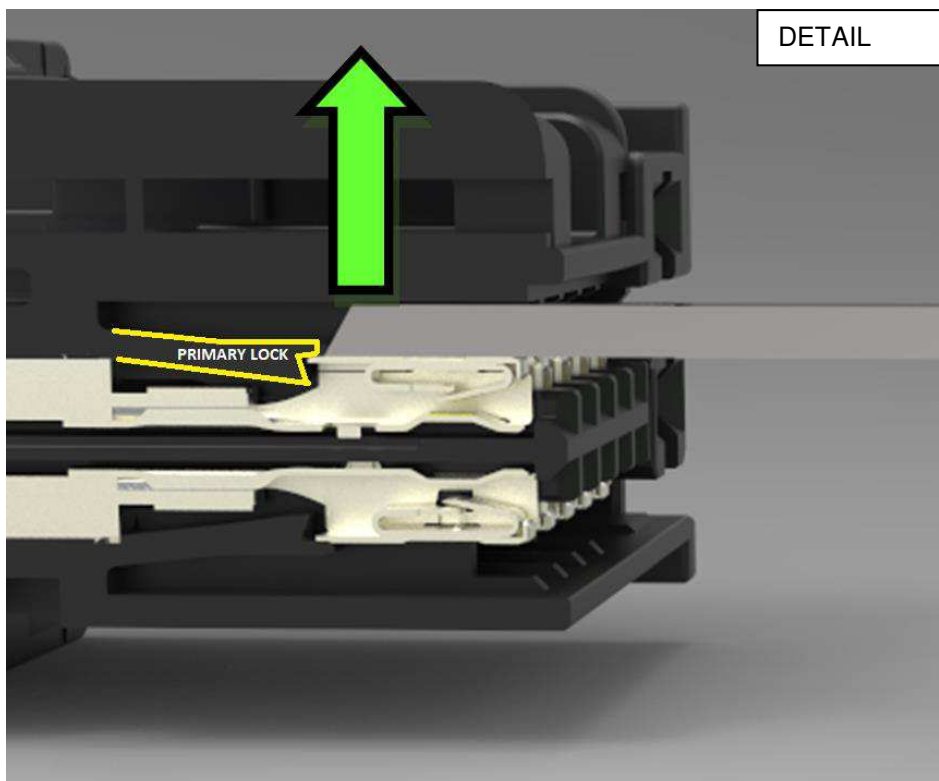

Revision	Description	Originator	Approver	Date
A	Initial Release	J. Wagner	H. Ripper	16 th August 2018
B	Correction	J. Wagner	H. Ripper	22 nd August 2018
B1	Correction	J. Wagner	H. Ripper	12 th October 2018