

Class 1

Application Specification Vehicle Charge Inlet Type CCS2 95mm2



Content

1.	SCOPE	3
1.1.	Content.....	3
1.2.	Processing Note.....	3
2.	APPLICABLE DOCUMENTS	4
2.1.	TE Connectivity Documents.....	4
2.2.	General Documentation.....	6
3.	APPLICATION TOOLS	7
4.	Wires	7
4.1.	Assessment of the wires.....	7
4.2.	Wire selection.....	7
4.3.	Wire preparation.....	7
5.	Requirements on the crimped contact with W-crimp shape (closed barrel)	8
5.1.	Conductor position.....	8
5.2.	Crimp Geometry.....	8
5.3.	Cross Sections.....	9
5.4.	Wire pull-out forces.....	9
5.5.	Crimp Position.....	10
5.6.	Contact area.....	10
5.7.	Sealing area.....	10
5.8.	Shape and position tolerances.....	11
5.9.	Measuring equipment and measuring position.....	11
6.	REQUIREMENTS ON THE WELD CONTACT WITH WELDING FLAG	12
7.	ASSEMBLY INSTRUCTIONS	13
7.1.	Assembly overview Charge Inlet Combo2.....	13
7.2.	Parts to order.....	17
7.3.	Assembly Configurations Cable Exit.....	20
7.4.	Kits to order	20
7.5.	Security Advice.....	21
7.6.	Assembly Steps	22
7.7.	End of Line Test	42
8.	Torque value for M6 screws	43
9.	Minimum length for cable fixation	44

1. SCOPE

1.1. Content

This specification describes the assembly and handling of the vehicle charge inlets Combo 2 acc. IEC62196-3 for conductive charging of electric vehicles with AC current and DC current for fast charging. This specification applies to manual assembly of the components in series production configuration.

1.2. Processing Note

The processor is responsible for the quality of the manufacturing process to ensure the correct function of the system. The warranty and liability are excluded if quality deficiency or damages occur due to non-compliance to this specification or use of not specified or not released tools, cables, and components.

2. APPLICABLE DOCUMENTS

The following technical documents, if referred to, are part of this specification. In case of a contradiction between this specification and the product drawing or this specification and the specified documentation, the product specification has priority.

2.1. TE Connectivity Documents

a) Customer drawings for inlet type Combo 2

CHARGE INLET ASSY WITH /WITHOUT AC AND WITH /WITHOUT LED CCS2	
INLET HSG, COMBO2, ASSY	2401362
PIN DIA 6.0, RIGID, POWER AC, ASSY,6mm ²	2293269
CHARGE INLET HSG, CAVITY PLUG	2389290
PIN DIA 6.0, RIGID, PE,25mm ²	2293270
PROTECTION CAP, WATER DRAIN	2292534
PIN, DIA8.0 CONTACT ASSY TYP2 (95mm ²).	2390840
PERIPHERIAL SEAL COMBO	2338079
CABLE EXIT, With / Without AC	2390858
SINGLE WIRE SEAL, AC	2401253
STRAIN RELIEF, AC	2401254
STRAIN RELIEF_PE, 25mm ²	2390861
SINGLE WIRE SEAL, 25mm ²	2418661
CABLE COVER, PE	2369840
CABLE COVER, AC	2401256
GROMMET SEAL, 7X0.35/0.5mm ² WIRE	2418662
GROMMET SEAL, 11X0.35/0.5mm ² WIRE	2401251
LV WIRE COVER	2369838
RADIAL SEAL, 95mm ²	2399667
STRAIN RELIEF, 95mm ²	2399668
DC, SINGLE SEAL COVER, 95mm ²	2399669
SEALING	2338077
MQS CAVITY PLUG	963143
FLAP, ASSY, INLET COMBO 2, LEFT / RIGHT, WITH / WITHOUT LED	2358664

b) Specifications

108-94907	Product Spec. Vehicle Charge Inlets Combo 2
114-13000	Application Specification Micro Mate-N-Lock Connectors
108-94519	Product Specification Vehicle Charge Inlet Actuator GEN 2
114-94842	Dia 8mm, Pin Terminal, Welding Application of Ultrasonic Weld Connection
114-18061	Application Specification MQS Connectors sealed

2.2. General Documentation

Cable Specifications of Prescribed Cables

AC-cable: cross-section 4 x 6,0mm²

Supplier	Coroplast
Outer Diameter	15,1 -0,5 mm
Min. bending radius	3xD (static)
Cable description	<i>FHLR2GCB2G 4x6.0mm²</i> <i>similar LV216-2 class F (T200)</i> <i>TPJLR.18.007, Issue 3</i>
Supplier Part No.:	9-2641 (4x6mm ²)

DC-HV-Cable : Cross-section 95mm²

Supplier	HUBER+SUHNER
Outer Diameter	19.9 ± 0.4 mm
Cable description:	<i>FHLR91XC13X and FHLR4GC13X (RADOX 155(S))</i>
Supplier Part No.:	84100299

PE-cable: cross-section 25mm²

Supplier	HUBER+SUHNER
Outer Diameter	8.20mm ±0.20 mm
Cable description	AUTOL 155 25MM2P GNYE
Supplier Part No.:	85066283

Signal-cable: cross-section 0,5mm²

Supplier	Several
Outer Diameter	1.6-0.2 mm
Cable description	<i>FLRY-0.5 A</i>
Supplier Part No.:	515274

3. APPLICATION TOOLS

To produce a correct wire crimp, as validated by TE with the wires listed in this specification, following application tools are required.

Wire Size [mm ²]	Stripping Length single wire for crimp [mm]	Crimp /WELD height CH ₁ [mm]	Cable Specification	Supplier	Contact P/N	Geometry	Applicator	TE Crimp Validation is based on crimp press stroke / cycle time
0.5	3.2 ± 0.1	0.89 ± 0.05	FLRY-A 0.5mm ²	SEVERAL	0-794606-1	F	2151022-1	G-Terminator PN 354500-1 Cycle Time:<500ms
4x6	13,0 ± 1	3,7 ± 0,1	FHLR2GCB2G 4x6.0mm ²	COROPLAST	2293269-3	W	2326368-1	Hanke 971-200. Cycle time: 1.7 - 2.5s Stroke: 44mm
25	18,0 ± 1	6.3 ± 0.15	AUTOL 155 25MM2P GNYE 25 mm ²	HUBER+SUHNER	2293270-5		2276149-6	
95	Acc. to application specification 114-94842							

Table 1

Crimp Die Sets are subject to wear and their condition and quality have to be monitored. Suspect and/or worn Die Sets have not to be used for the production of these crimps. Die Sets are available as spare parts.

4. WIRES

4.1. Assessment of the wires

To ensure the required electrical crimp contractability with stable crimp resistance a permissible maximum storage period of 8 months for unprocessed cable (referring to cable manufacturer production date) has to be respected.

4.2. Wire selection

The contact system is released for the application with wires specified in chapter 2.2
The released contact-wire-combinations and crimp parameters are given in table 1.

Other wires require the validation and approval of the TE engineering department.
The wires are applied as single wire terminations. Double terminations are not intended.

4.3. Wire preparation

The cable has to be cut accurately with a 90 deg angle.

The cable insulation must be stripped before crimping. The stripping length of the outer insulation and shield is defined in the following Assembly Steps.

The insulation must be cut accurately and pulled off from the conductor. Offcut of insulation must not remain on the conductor. Single strands may not be damaged, fanned out, cut or pulled out. Furthermore, the operator should avoid touching the bare single strands and the strands shall not be twisted. All single strands need to be caught in the crimp and not a single strand must remain outside the crimp.

5. REQUIREMENTS ON THE CRIMPED CONTACT WITH W-CRIMP SHAPE (CLOSED BARREL)

The following terms shown below are used in this specification, see Figure 1.

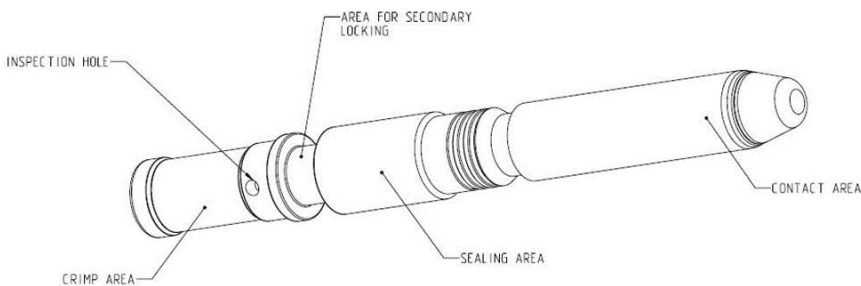

Figure 1

5.1. Conductor position

The single strands of the conductor are clamped inside the crimp area. All single strands need to be caught in the crimp and not a single strand must remain outside the crimp. The wire end must be fully inserted into the crimp area and has to be checked via the inspection hole after crimping. Insulation must not be inside of the crimping area, see Figure 2

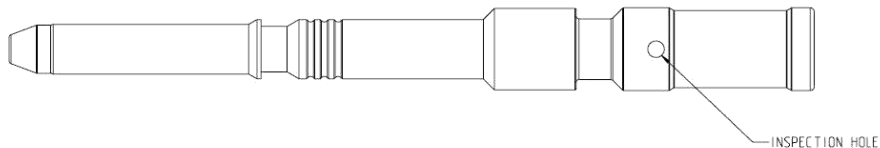

Figure 2

5.2. Crimp Geometry

The crimp geometry, crimp heights including their corresponding tolerances as well as wire sizes are given in table 1.

The crimp height is the key quality feature of a crimp connection. The measurement allows a non-destructing examination and a continuous process inspection. It is provided for every wire size and contact. The crimp height is given in table 2.

Crimp height and width may also be measured in a cross-section image. The mechanical operated measurement though is preferred.

During the application process the crimp height must be checked. This is valid for each batch and after every change or switchover of contact reel or wire bundle or applicator respective it's setup or components.

The crimp height has to be measured over both extensions in middle of the crimp, Figure 3:



Figure 3 (picture exemplarily)

5.3. Cross Sections

When creating cross-sections, the correct grinding layer must be selected. The Grinding layer had to be at middle of crimp area and may not be inside of serration, see Figure 4.

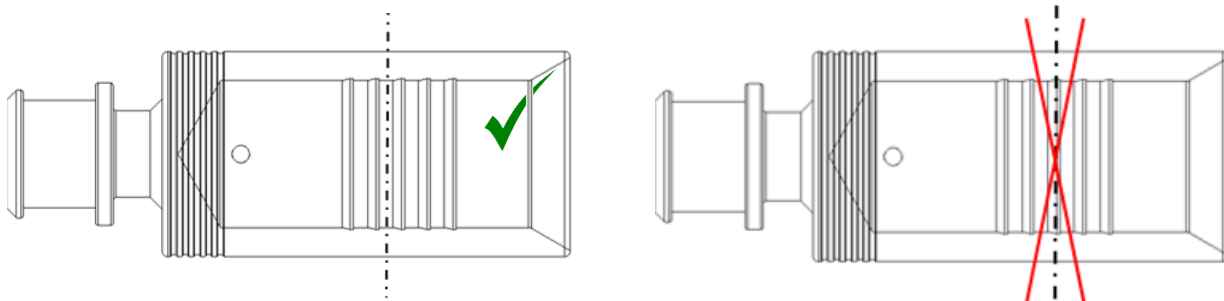

Figure 4 (picture exemplarily)

5.4. Wire pull-out forces

Measurement of wire pull-out forces from the wire crimp is a supporting manufacturing control.

The pull-out forces must fulfil the requirements according to application specification 114-94391

5.5. Crimp Position

The TE applicator positions the contacts in the crimping tool at middle position as shown, Figure 5 and 6. Correct position and condition of applicator has to be checked for every production lot.

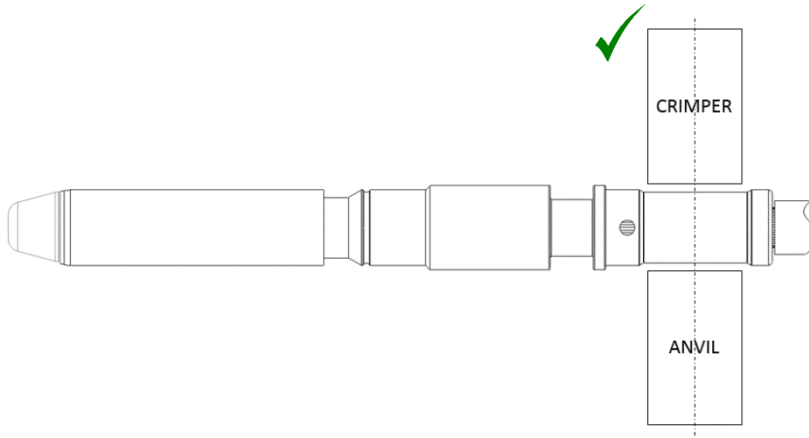

Figure 5 (picture exemplarily)

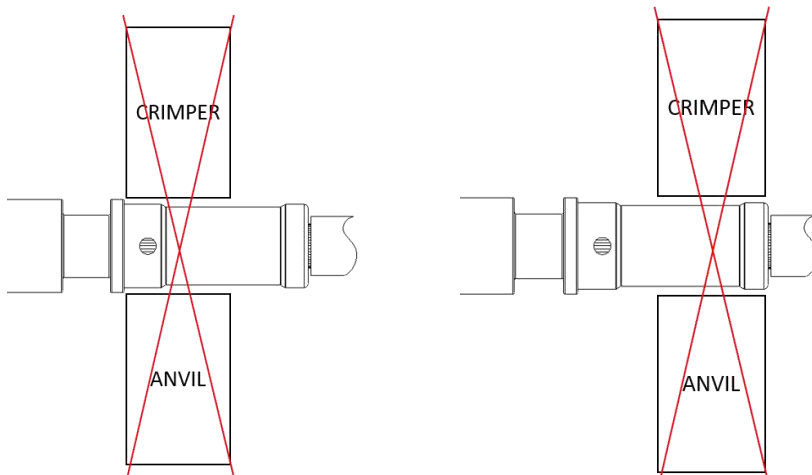

Figure 6 (picture exemplarily)

5.6. Contact area

During processing and following processing, the contact area may not be damaged or bended.

5.7. Sealing area

During processing and following processing, the sealing area may not be damaged or bended

5.8. Shape and position tolerances

Measuring the shape and position deviation is not always necessary if the contact is obviously straight by eye. In case a measurement is required, the measurement equipment required at least a 10-time better measuring precision compared with the requirement tolerances, see Figure 7 and 8.

Meeting the specific shape and position tolerances must be ensured before the contact is inserted into the housing.

If contacts are bent during the application process and exceed the specified tolerances these must not be bent back or reworked but must be scrapped.

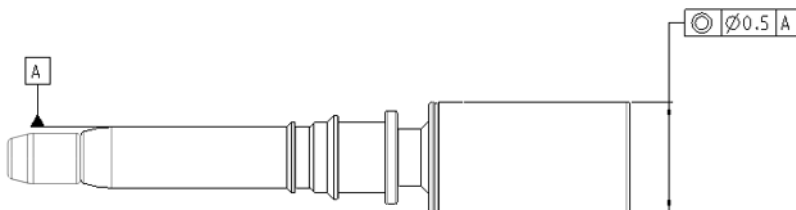

Figure 7 (picture exemplarily)

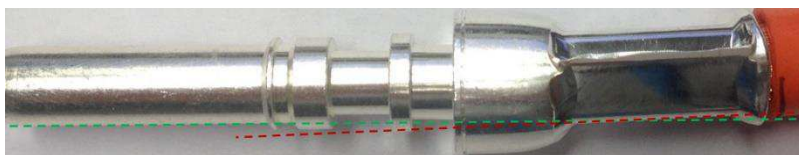

Figure 8 (picture exemplarily)

5.9. Measuring equipment and measuring position

As measuring equipment for measuring crimp height, a digital caliper with accuracy of measuring 0.01mm is the minimum requirement. Measuring of crimp height had to be done according as following always in middle of crimp area across whole crimp, see Figure 9 and Figure 3.



Figure 9 (picture exemplarily)

6. REQUIREMENTS ON THE WELD CONTACT WITH WELDING FLAG

The welding of the 95 mm² cables on 180 DEG DC power contacts with weld flag geometry has to be processed according to Application Specification 114-94842.

7. ASSEMBLY INSTRUCTIONS

7.1. Assembly overview Charge Inlet Combo2

Charge Inlet Combo 2 w/o AC & w/o LED Kit

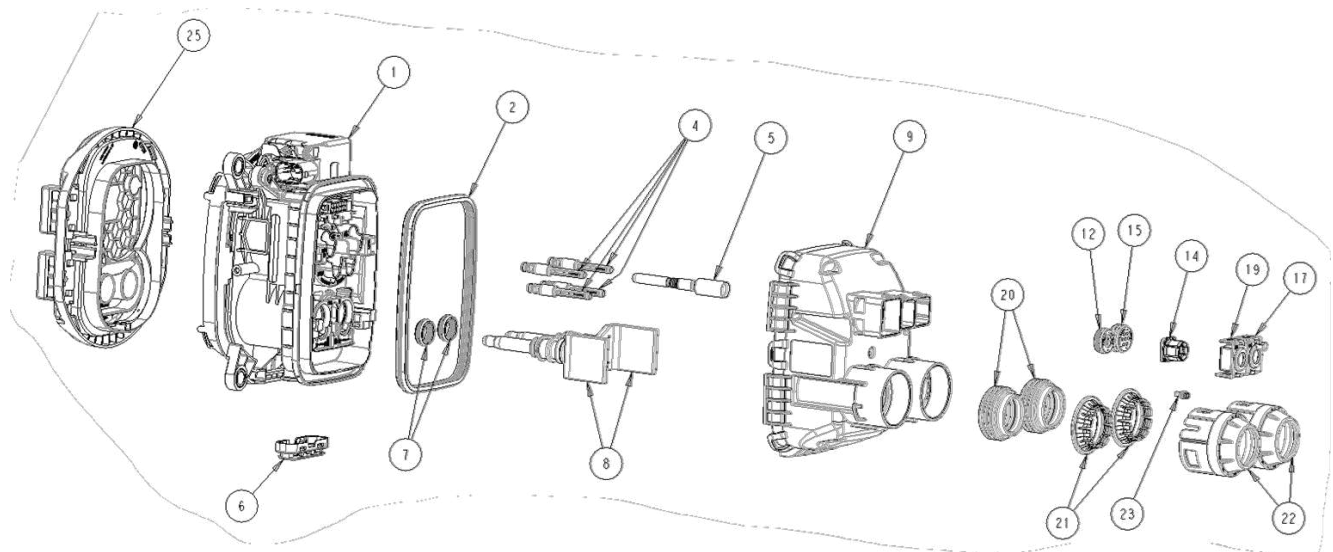

Figure 10a

Charge Inlet Combo 2 with AC & with LED Kit

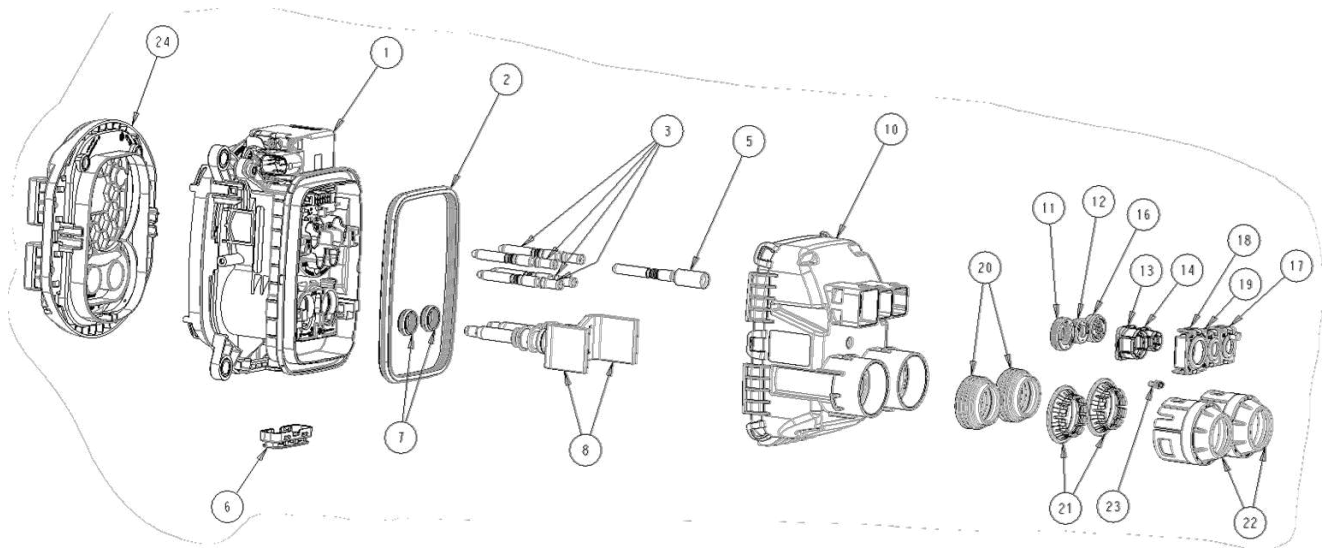

Figure 10b

Charge Inlet Combo 2 with AC & w/o LED Kit

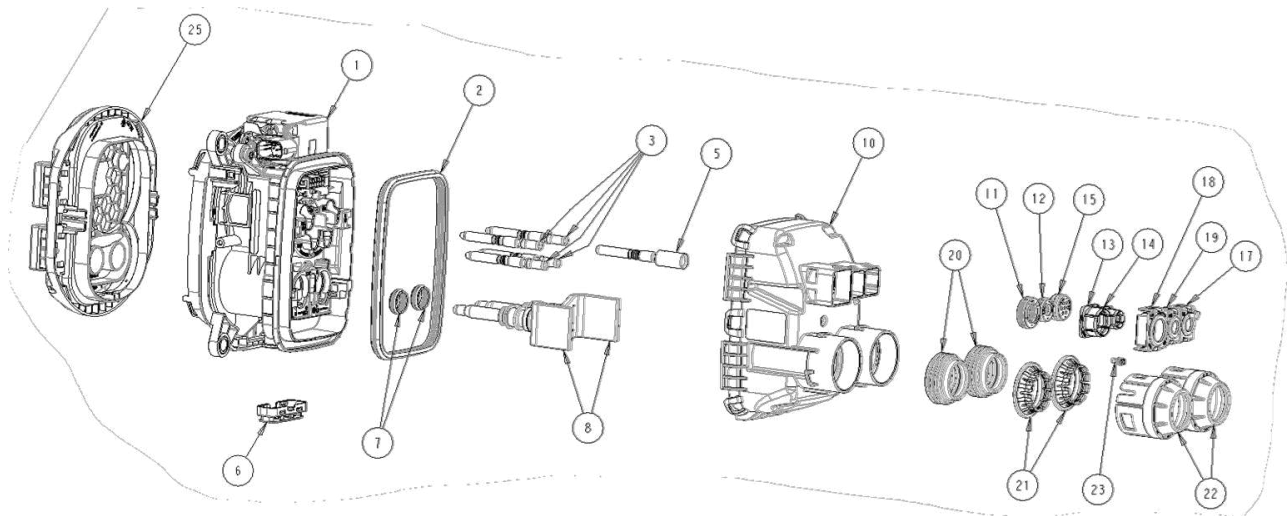

Figure 10c

Charge Inlet Combo 2 w/o AC & with LED Kit

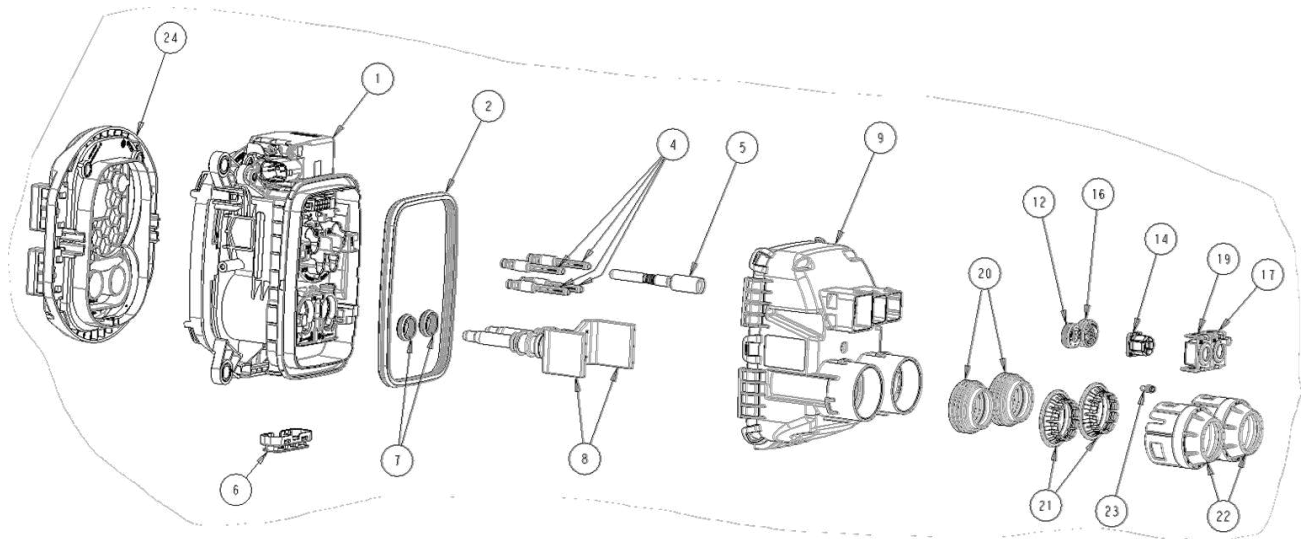

Figure 10d

7.2.1 Parts to order for 12V Actuator Variants

CHARGE INLET ASSY WITH LED CCS2			Charge Inlet w/o AC & w/o LED	Charge Inlet with AC & With LED	Charge Inlet w/o AC & with LED	Charge Inlet with AC & w/o LED
Variant			Ground 25mm ² DC 95 mm ²	3-phase AC 6mm ² Ground 25mm ² DC 95 mm ²	Ground 25mm ² DC 95 mm ²	3-phase AC 6mm ² Ground 25mm ² DC 95 mm ²
Pos	Qty.	Name	P/N	P/N		
1	1	INLET HSG, COMBO2, ASSY	2401362-1	2401362-2	2401362-1	2401362-2
-	1	12P MICRO MNL HSG (Additional part for charge inlet cabling)	1-794617-2	1-794617-2	1-794617-2	1-794617-2
	7	CONTACT MICRO MNL (0.5mm ²) (Additional part for charge inlet cabling)	0-794606-1	-	-	0-794606-1
	11	CONTACT MICRO MNL (0.5mm ²) (Additional part for charge inlet cabling)	-	0-794606-1	0-794606-1	-
2	1	Radial Sealing Cable Exit	2338079-1	2338079-1	2338079-1	2338079-1
3	4	PIN DIA 6.0, RIGID, POWER AC, ASSY (6mm ²)	-	2293269-3	-	2293269-3
4	4	CHARGE INLET HSG,CAVITY PLUG	2389290-2	-	2389290-2	-
5	1	PIN DIA 6.0, RIDIG, PE (25mm ²)	2293270-5	2293270-5	2293270-5	2293270-5
6	1	PROTECTION CAP, TE, WATER DRAIN	2292534-1	2292534-1	2292534-1	2292534-1
7	2	SEALING	2338077-1	2338077-1	2338077-1	2338077-1
8	2	PIN DIA 8.0, 180 DEG, CONTACT, ASSY TYP 2, (95mm ²)	2390840-1	2390840-1	2390840-1	2390840-1
9	1	CABLE EXIT, w/o AC	2390858-1	-	2390858-1	-
10	1	CABLE EXIT, with AC	-	2390858-2	-	2390858-2
11	1	SINGLE WIRE SEAL, AC	-	2401253-1	-	2401253-1
12	1	SINGLE WIRE SEAL, PE	2418661-1	2418661-1	2418661-1	2418661-1
13	1	STRAIN RELIEF, AC	-	2401254-1	-	2401254-1
14	1	STRAIN RELIEF, PE	2390861-1	2390861-1	2390861-1	2390861-1

15	1	GROMMET SEAL, 7X0.35/0.5mm ² WIRE	2418662-1	-	-	2418662-1
16	1	GROMMET SEAL, 11X0.35/0.5mm ² WIRE	-	2401251-1	2401251-1	-
17	1	LV WIRE COVER	2369838-1	2369838-1	2369838-1	2369838-1
18	1	CABLE COVER, AC	-	2401256-1	-	2401256-1
19	1	CABLE COVER, PE	2369840-3	2369840-3	2369840-3	2369840-3
20	2	RADIAL SEAL, 95mm ²	2399667-2	2399667-2	2399667-2	2399667-2
21	2	STRAIN RELIEF, 95mm ²	2399668-2	2399668-2	2399668-2	2399668-2
22	2	DC, SINGLE SEAL COVER, 95mm ²	2399669-2	2399669-2	2399669-2	2399669-2
23	1	MQS CAVITY PLUG FOR CENTERLINE 4 MM	963143-1	963143-1	963143-1	963143-1
-	-	4POS MQS Connector HSG, Seals and Contacts (Additional part for charge inlet cabling)	p/n acc. Prod. Spec. 108-94519	p/n acc. Prod. Spec. 108-94519	p/n acc. Prod. Spec. 108-94519	p/n acc. Prod. Spec. 108-94519
24	1	Optional: FLAP, SLIM COMBO 2, ASSY, LED	2358664-6			
25	1	Optional: FLAP, SLIM COMBO 2, ASSY	2358664-2			

Table 2

7.2.2 Parts to order for 24V Actuator Variants

CHARGE INLET ASSY WITH LED CCS2			Charge Inlet w/o AC & w/o LED	Charge Inlet with AC & With LED	Charge Inlet w/o AC & with LED	Charge Inlet with AC & w/o LED
Variant			Ground 25mm ² DC 95 mm ²	3-phase AC 6mm ² Ground 25mm ² DC 95 mm ²	Ground 25mm ² DC 95 mm ²	3-phase AC 6mm ² Ground 25mm ² DC 95 mm ²
Pos	Qty.	Name	P/N	P/N		
1	1	INLET HSG, COMBO2, ASSY	2401362-3	2401362-4	2401362-3	2401362-4
-	1	12P MICRO MNL HSG (Additional part for charge inlet cabling)	1-794617-2	1-794617-2	1-794617-2	1-794617-2
	7	CONTACT MICRO MNL (0.5mm ²) (Additional part for charge inlet cabling)	0-794606-1	-	-	0-794606-1

	11	CONTACT MICRO MNL (0.5mm ²) (Additional part for charge inlet cabling)	-	0-794606-1	0-794606-1	-
2	1	Radial Sealing Cable Exit	2338079-1	2338079-1	2338079-1	2338079-1
3	4	PIN DIA 6.0, RIGID, POWER AC, ASSY (6mm ²)	-	2293269-3	-	2293269-3
4	4	CHARGE INLET HSG,CAVITY PLUG	2389290-2	-	2389290-2	-
5	1	PIN DIA 6.0, RIDIG, PE (25mm ²)	2293270-5	2293270-5	2293270-5	2293270-5
6	1	PROTECTION CAP, TE, WATER DRAIN	2292534-1	2292534-1	2292534-1	2292534-1
7	2	SEALING	2338077-1	2338077-1	2338077-1	2338077-1
8	2	PIN DIA 8.0, 180 DEG, CONTACT, ASSY TYP 2, (95mm ²)	2390840-1	2390840-1	2390840-1	2390840-1
9	1	CABLE EXIT, w/o AC	2390858-1	-	2390858-1	-
10	1	CABLE EXIT, with AC	-	2390858-2	-	2390858-2
11	1	SINGLE WIRE SEAL, AC	-	2401253-1	-	2401253-1
12	1	SINGLE WIRE SEAL, PE	2418661-1	2418661-1	2418661-1	2418661-1
13	1	STRAIN RELIEF, AC	-	2401254-1	-	2401254-1
14	1	STRAIN RELIEF, PE	2390861-1	2390861-1	2390861-1	2390861-1
15	1	GROMMET SEAL, 7X0.35/0.5mm ² WIRE	2418662-1	-	-	2418662-1
16	1	GROMMET SEAL, 11X0.35/0.5mm ² WIRE	-	2401251-1	2401251-1	-
17	1	LV WIRE COVER	2369838-1	2369838-1	2369838-1	2369838-1
18	1	CABLE COVER, AC	-	2401256-1	-	2401256-1
19	1	CABLE COVER, PE	2369840-3	2369840-3	2369840-3	2369840-3
20	2	RADIAL SEAL, 95mm ²	2399667-2	2399667-2	2399667-2	2399667-2
21	2	STRAIN RELIEF, 95mm ²	2399668-2	2399668-2	2399668-2	2399668-2
22	2	DC, SINGLE SEAL COVER, 95mm ²	2399669-2	2399669-2	2399669-2	2399669-2

23	1	MQS CAVITY PLUG FOR CENTERLINE 4 MM	963143-1	963143-1	963143-1	963143-1
-	-	4POS MQS Connector HSG, Seals and Contacts (Additional part for charge inlet cabling)	p/n acc. Prod. Spec. 108-94519	p/n acc. Prod. Spec. 108-94519	p/n acc. Prod. Spec. 108-94519	p/n acc. Prod. Spec. 108-94519
24	1	Optional: FLAP, SLIM COMBO 2, ASSY, LED	2358664-6			
25	1	Optional: FLAP, SLIM COMBO 2, ASSY	2358664-2			

Table 3

7.3 Assembly Configurations Cable Exit

The inlet is designed for cable exit directions straight. The configuration shown in Figure 11 the definition is according to view from the Charging Inlet front.

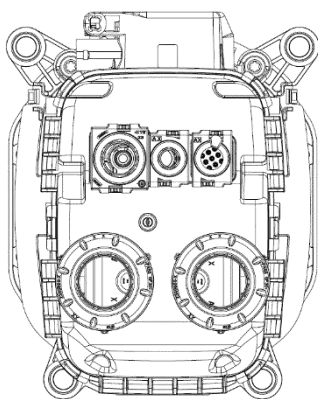

Figure 11

To the right side

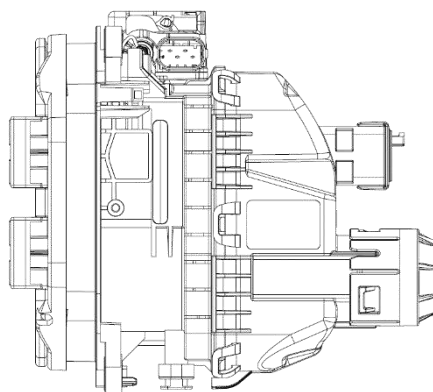

Figure 12

7.4 Kits to order

Sets optional including Flap Unit Assembly

Additional parts according to table 2 above must be considered for Charge Inlet cabling!

See Figure 10 and 11.

COMBO 2 CHARGE INLET ASSY W/O AC & WITH LED, 12V ACTUATOR	COMBO 2 CHARGE INLET ASSY With AC & With LED, 12V ACTUATOR	COMBO 2 CHARGE INLET ASSY WITH AC & W/O LED, 12V ACTUATOR	COMBO 2 CHARGE INLET ASSY W/O AC & W/O LED, 12V ACTUATOR
COMBO 2 CHARGE INLET ASSY W/O AC & WITH LED, 24V ACTUATOR	COMBO 2 CHARGE INLET ASSY With AC & With LED, 24V ACTUATOR	COMBO 2 CHARGE INLET ASSY WITH AC & W/O LED, 24V ACTUATOR	COMBO 2 CHARGE INLET ASSY W/O AC & W/O LED, 24V ACTUATOR

Table 4

7.5 Security Advice

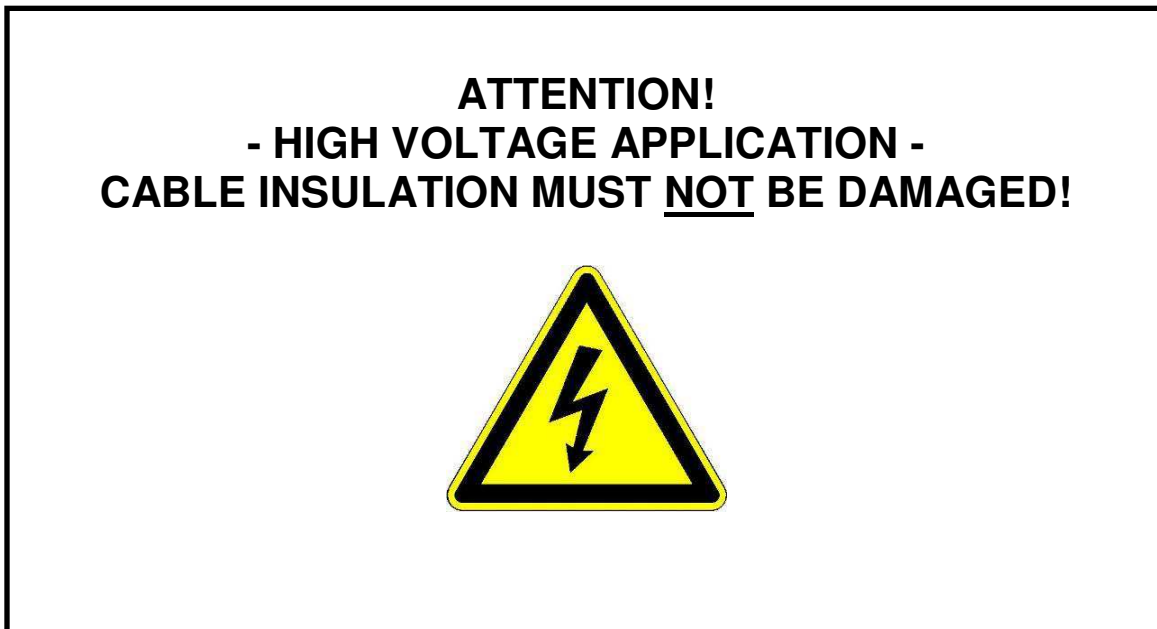

The assembly has only be performed by trained personnel.

Avoid prolonged or repeated skin contact with silver plated contacts (wear protective gloves)!

7.6 Assembly Steps

Step 1

The AC, PE & SIGNAL COVER, AC & PE STRAIN RELIEF and AC, PE & SIGNAL SEAL must be pushed over the signal wires, the ground wire and the AC-Multicore wire. Pay attention to place all wires at correct positions, Figure 13. Especially ensure the correct position of the SEAL AC and the SEAL PE towards the respective STRAIN RELIEF, Figure 13a.

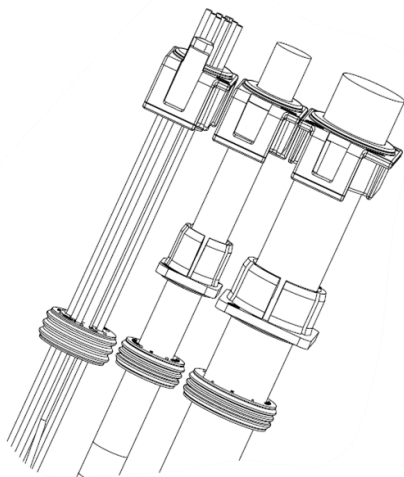

Figure 13

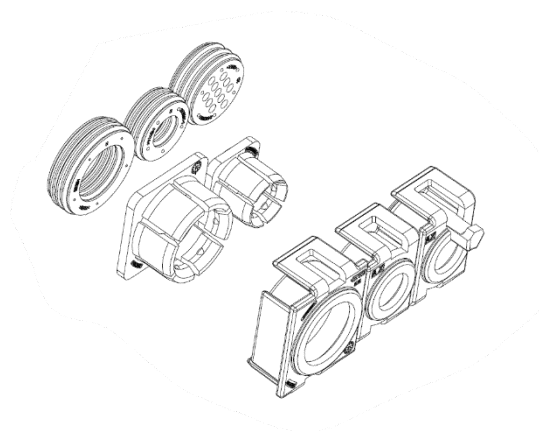

Figure 13a

Step 2

Dismantle the wires and crimp the contacts: **4x6 mm² AC-Multicore Cable**

Remove outer insulation shield and filler of AC-multicore-cable acc. Figure 14 and table 4. The given length of the single wires ensures that the outer sheath of the multicore cable seals to the SINGLE WIRE SEAL AC 2401253-1. Alternatively, a marking on the outer sheath in a certain distance to the cut off position can be used to ensure the proper position of the outer sheath in the SINGLE WIRE SEAL AC.

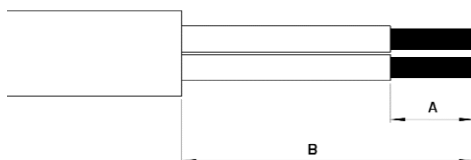

Figure 14 (schematic view)

Wire Size	Removal of insulation dim. "A"	Length of single wires "B"
4x6 mm ²	13 mm +/- 1mm	68 +/-2 mm

Table 5

Crimp the conductors to the PIN DIA6,0 RIGID CONTACTS 2293269-3 with the specified tools listed in table 1. The crimp has to fulfil the requirements acc. Chapter 5.

Step 3

Dismantle the wires and crimp the contact: **25 mm² PE (ground) single wire**

Remove outer insulation acc. Figure 15 and table 5.

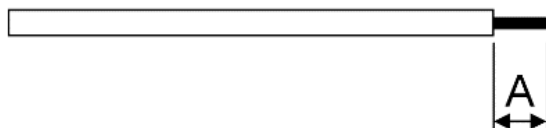

Figure 15

Wire Size	Removal of insulation dim. "A"	Needed wire length inside inlet
25 mm ²	18 mm +/- 1mm	78 ± 5 mm

Table 6

Crimp the conductors to the PIN DIA 6,0 RIGID CONTACT 2293270-5 with the specified tools listed in table 1. The crimp has to fulfil the requirements acc. Chapter 5.

Step 4

Dismantle the wires and crimp the contacts: **Signal-Wires 0,5mm²**

Dismantle single wires acc. spec. 114-13000 and crimp the contacts 0-794606-1 acc. spec. 114-13000, see Figure 16.

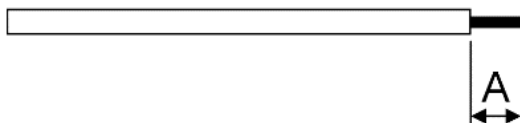

Figure 16

After Crimping the different cables, the subassembly of cables with cable exit components is in the condition shown in Figure 17:

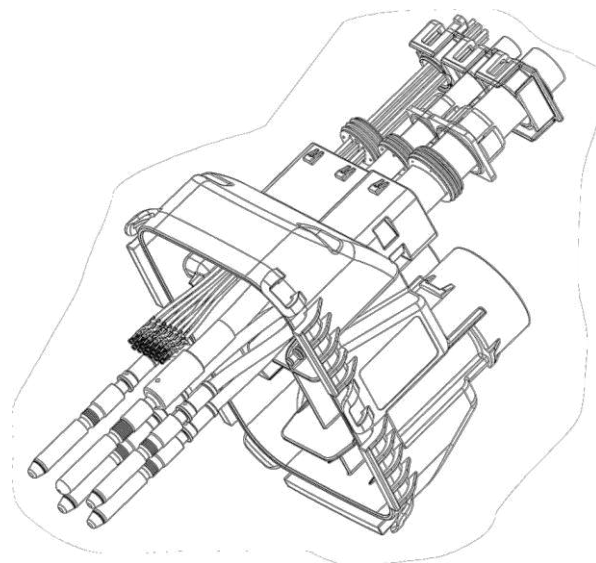

Figure 17 (schematic; crimp geometry not shown)

Step 5

Push signal terminals 794606-1 (Micro Mate 'N' Lock) into the Connector Housing 1-794617-2 acc. application spec 114-13000. Pinning according to Figure 18 and table 6a & 6b for with & W/O LED:

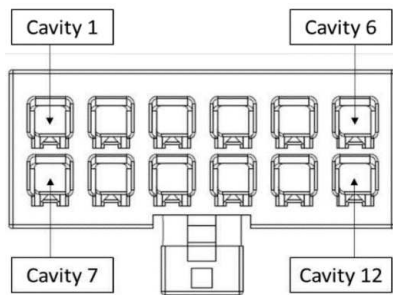

Figure 18

Cavity No.	Function
1	LED gn
2	LED rd
3	-
4	GND LED
5	LED wt
6	T DC+
7	Proxi
8	T GND
9	T DC-
10	T AC
11	PE S
12	CP

Table 7a

Cavity No.	Function
6	T DC+
7	Proxi
8	GND , Temp
9	T DC-
10	T AC
11	PE S
12	CP

Table 7b

After Micro Mate 'N' Lock connector housing assembly the subassembly of cables with cable exit components is complete, see Figure 19

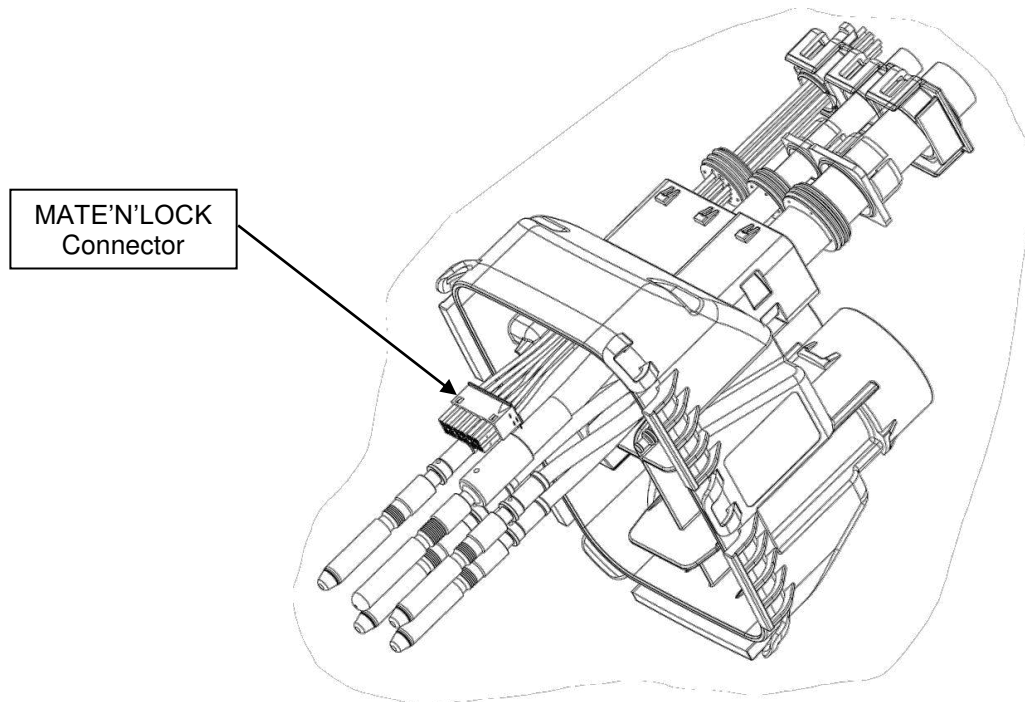

Figure 19 (schematic; crimp geometry not shown)

Step 6

The RADIAL SEAL DC, 95MM² 2399667-2 and STRAIN RELIEF DC, 95MM² 2399668-2 and DC, SINGLE SEAL COVER, 95mm² 2399669-2 must be pushed over the 95mm² DC-Power wires, Figure 20. Especially ensure the correct position of the RADIAL SEAL DC, and STRAIN RELIEF DC towards the COVER CABLE SEAL, Figure 20a

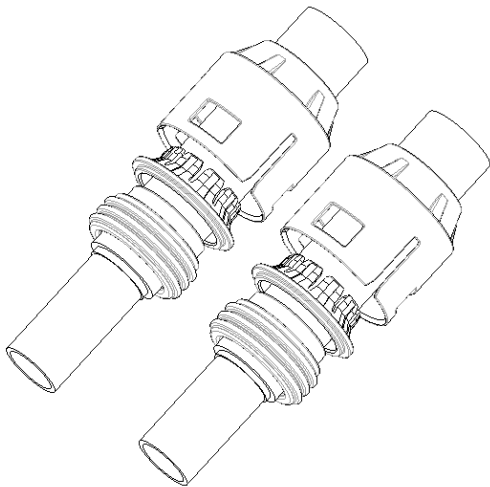

Figure 20

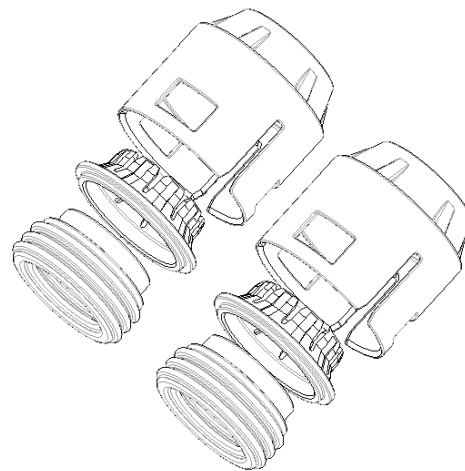

Figure 20a

Pass the cables through the DC area in the Cable Exit with AC 2390858-2 (Figure 21) or Cable Exit without AC 2390858-1 (Figure 21a)

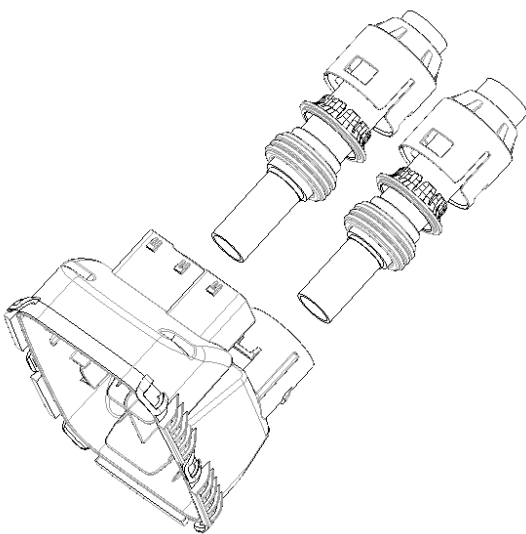

Figure 21

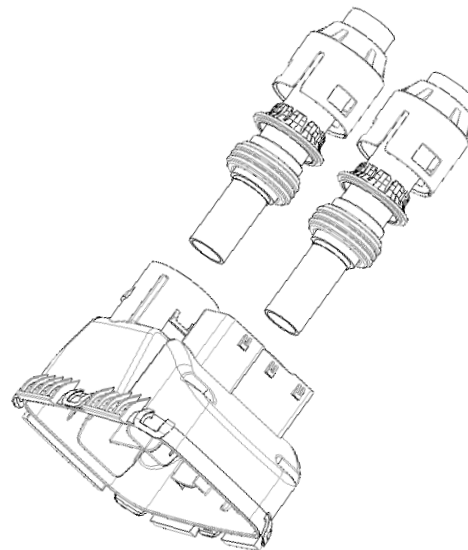

Figure 21a

Step 7

95 mm² DC Power Cables.

Strip the wires (Figure 23, Table 7), apply tape to completely cover the remaining cut shield braids and weld the contacts assemblies 2390840-1 according to the 114-94842 specification.

Make sure that the distance between the cut shield braids and the open conductor is MIN. 5 mm to ensure creepage and clearance requirements are maintained.

In addition to the 114-94842 specification make sure that the DC cable centerline to weld pad spacing is set. The DC cable centerline to weld pad spacing dimension shown below is required to ensure sealing (Figure 22).

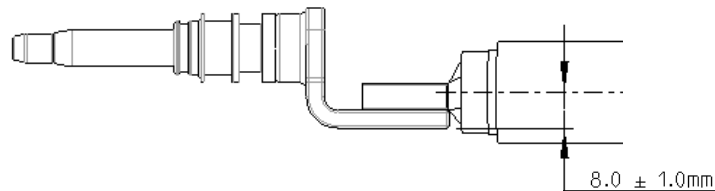

Figure 22

Strip the wires (Figure 23, Table 7), apply tape to completely cover the remaining cut shield braids and weld the contacts assemblies 2390840-1 according to the 114-94842 specification.

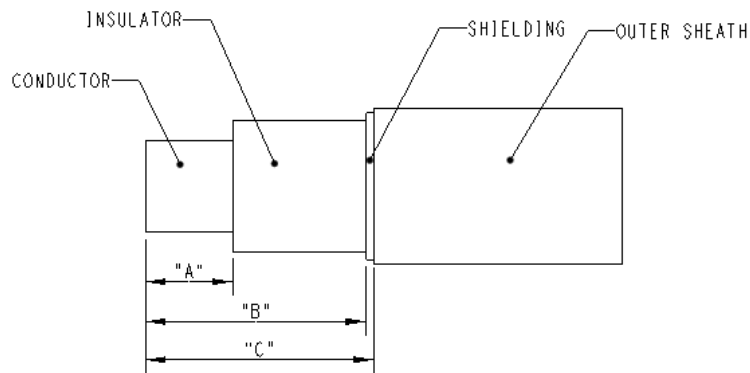

Figure 23

Position	A (Removal of inner isolation)	B (Removal of shield)	C (Removal of outer isolation)	Needed wire length inside inlet
DC +	20.5±0.1	29 ± 1 mm	31 ± 1 mm	66.5 ± 3 mm
DC -	20.5±0.1	29 ± 1 mm	31 ± 1 mm	66.5 ± 3 mm

Table 8

Apply the TESA 51618 tape of 19mm width onto the cut shielding like shown in Figure 23a. The number of loops of tape will be decided by the harness maker, however, need to ensure that the excess shield is completely covered with tape and the tape not on the sealing area.

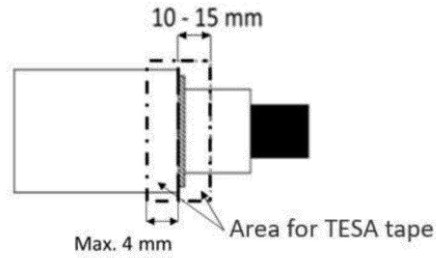

Figure 23a

Cable pin and spare part orientation is indicated in the below general picture on Figure 23b.

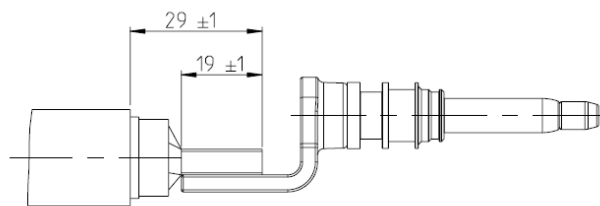

Figure 23b

For Charge Inlets with cable exit with AC and without AC weld need to be arranged as shown DC- on the top cable position, DC+ on the lower.

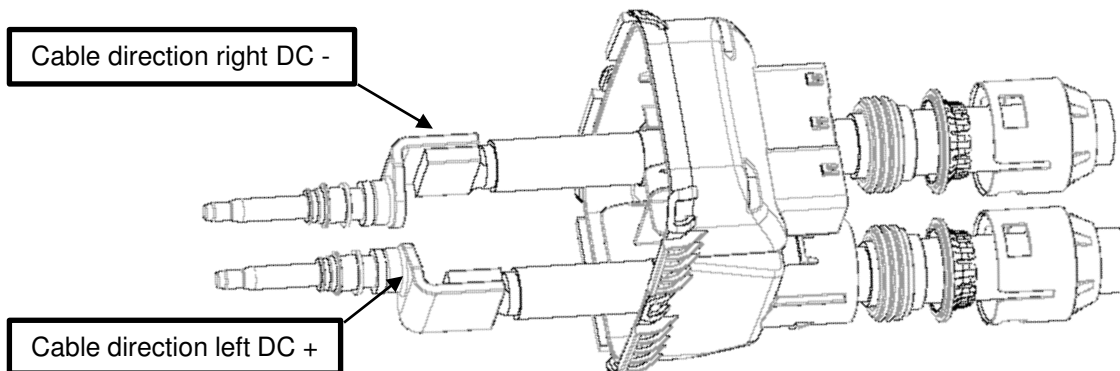

Figure 24

Step 8

Assemble the DC contact seals 2338077-1 on the DC contact assemblies. (Figure 25). Pay attention to not damage the seal during handling. Make sure the seal does not twist or flip around, correct assembly is shown in Figure 25a

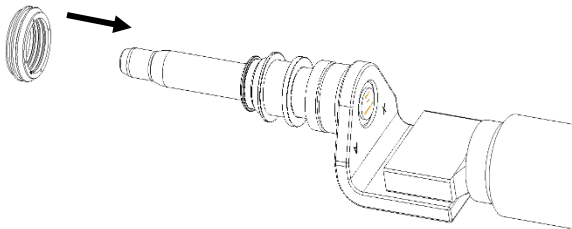

Figure 25

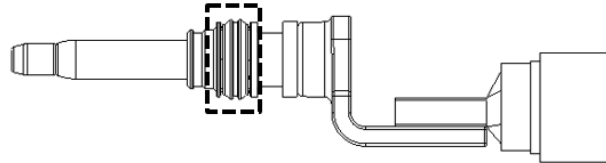

Figure 25a

Step 9

Pass the DC cable sub-assembly (Figure 19) through the DC slot in Cable Exit w/o AC 2390858-1 (Figure 26) or Cable Exit with AC 2390858-2 (Figure 26a).

ATTENTION: the inner surface of the two cylindrical DC exit and one rectangle feature are sealing surfaces thus must be intact and free from any scratch or damage could cause during the assembly process.

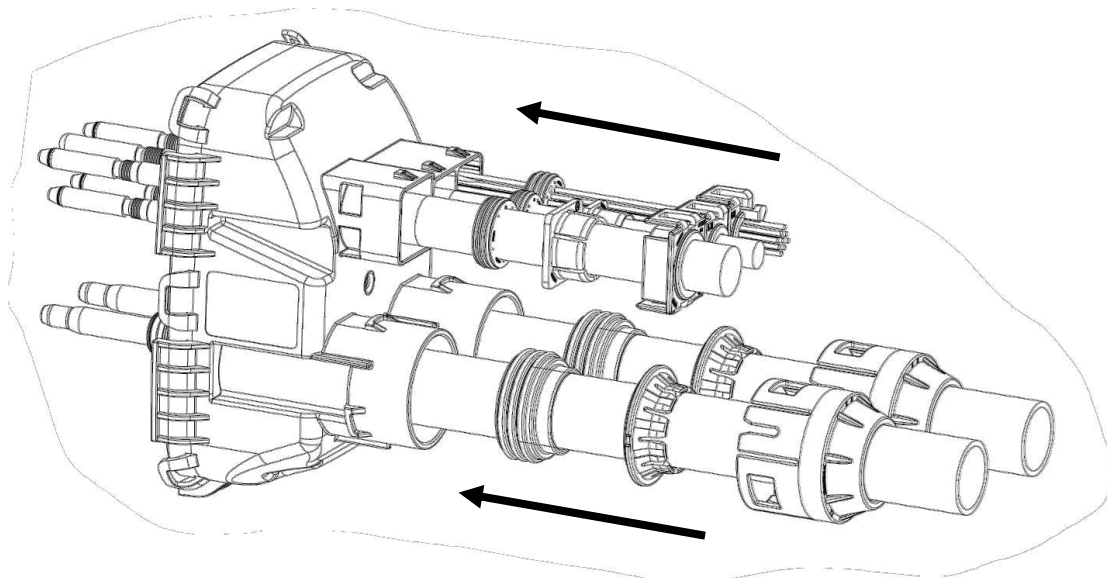

Figure 26 (exemplary)

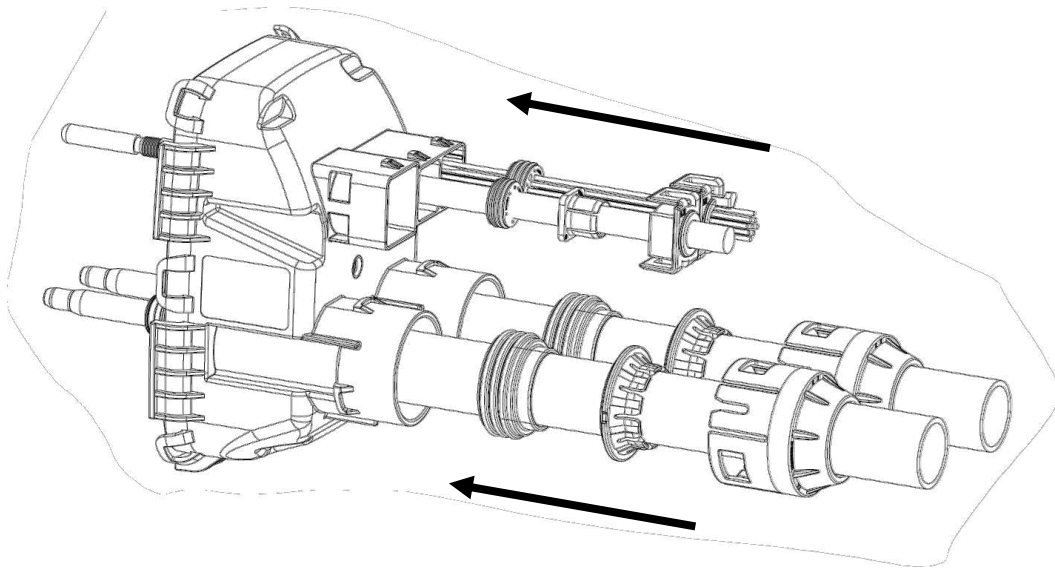

Figure 26a (exemplary)

Step 10

The PERIPHERAL SEAL, CHARGE INLET, 2338079-1 needs to be assembled before you move forward with the terminal assembly into the CHARGE INLET HSG, COMBO 2, ASSY 2401362.

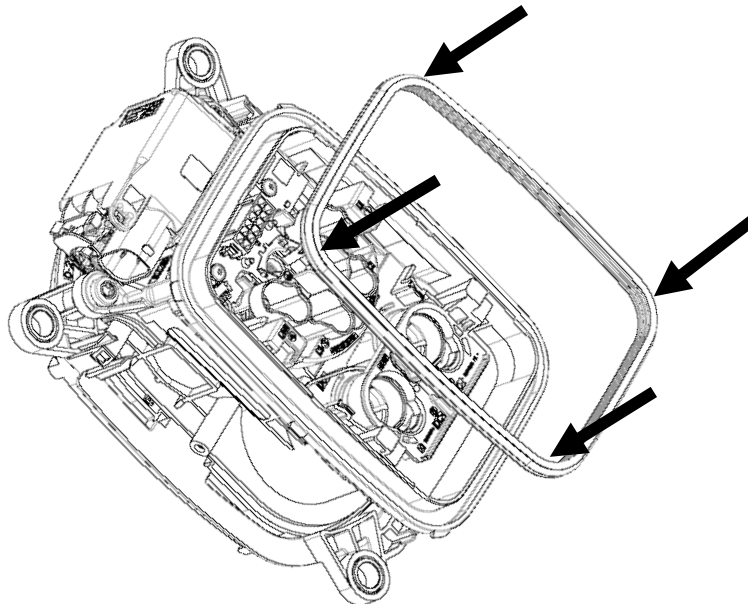

Figure 27

Step 11

Insert the Contacts from the backside into the Inlet Housing according to the cavity description (see Figure 28) into their locking position, see Figure 29. To ensure that the contacts are correctly inserted, pull with a low force on the cables (max. 10N). Figure 29a shows contacts assembled in end position.

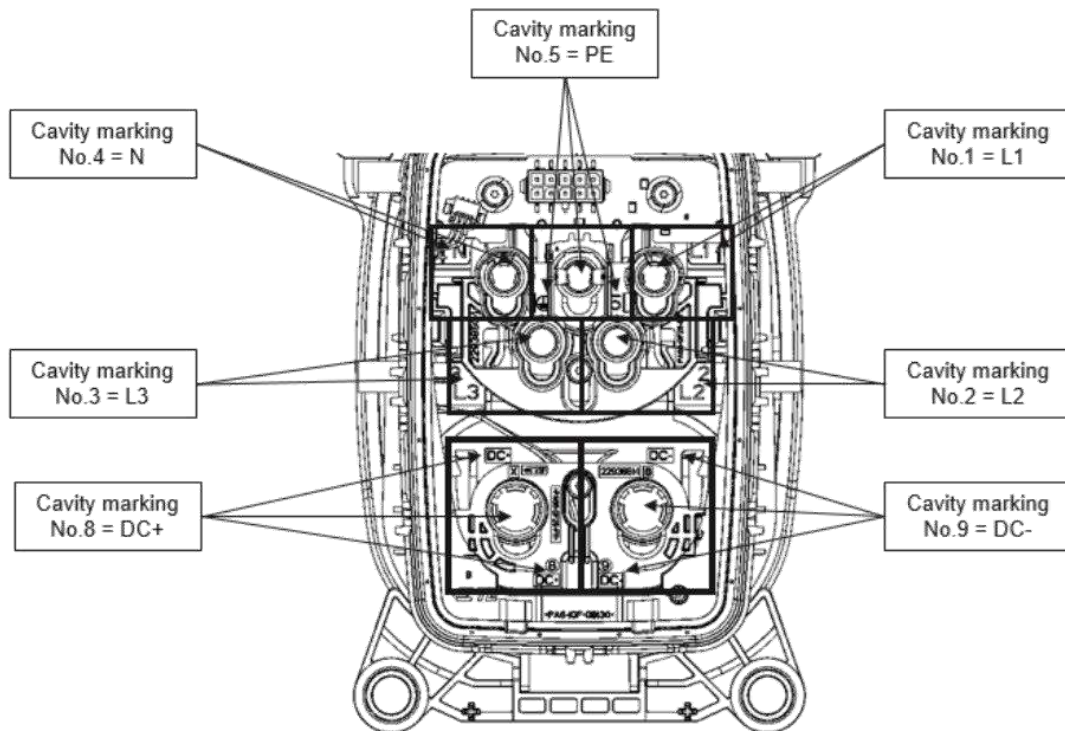

Figure 28

ATTENTION: The correct contact positions must be ensured BEFORE pushing the contacts into their cavities in locking position.

In case of wrong positioning of the contacts the complete assembly must be scrapped. There is no rework allowed (risk of damaging contacts and/or locking geometry in housing)!

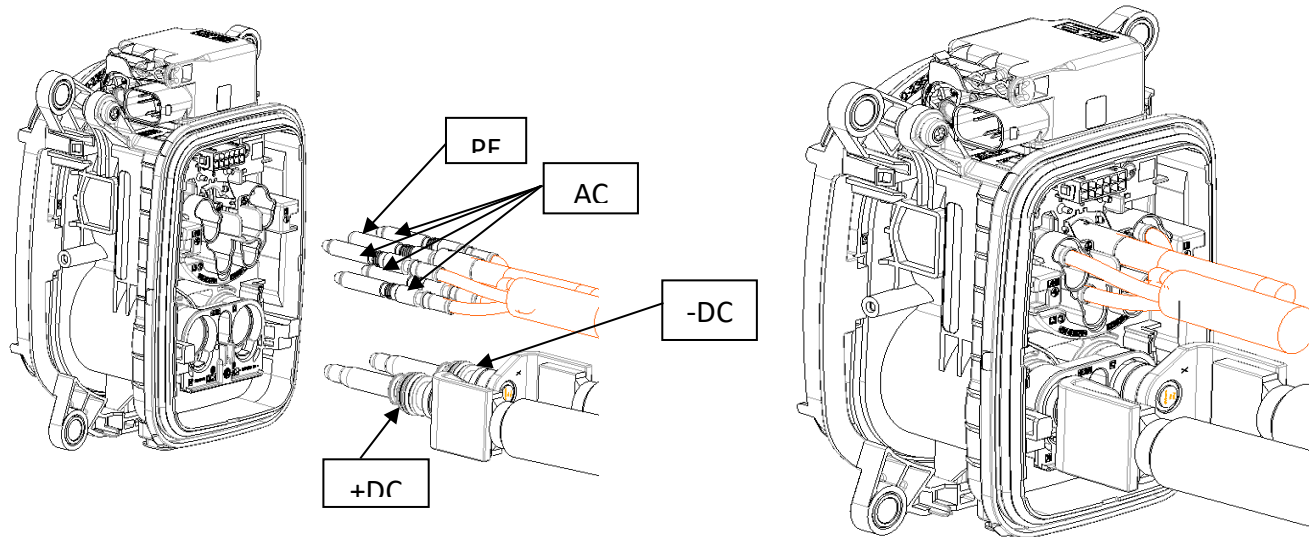

Figure 29

Figure 29a

Proposed sequence for contact insertion:

- 1.) 4x 6mm² AC Power Cable with contacts into L1, L2, L3 and N cavities
- 2.) 25 mm² Ground Cable with contact into PE/ground cavity
- 3.) 2x 95mm² DC Power Cable with contacts into DC+ and DC- cavities

Step 12

After the contacts have been controlled for correct positioning and locking, both **SECONDARY LOCKS** must be pushed upwards (Figure 30). Ensure that both latches are properly engaged with the inlet housing, which must be controlled by the double audible click and by visible inspection. Secondary Locks in end position shown in Figure 31 and 31a:

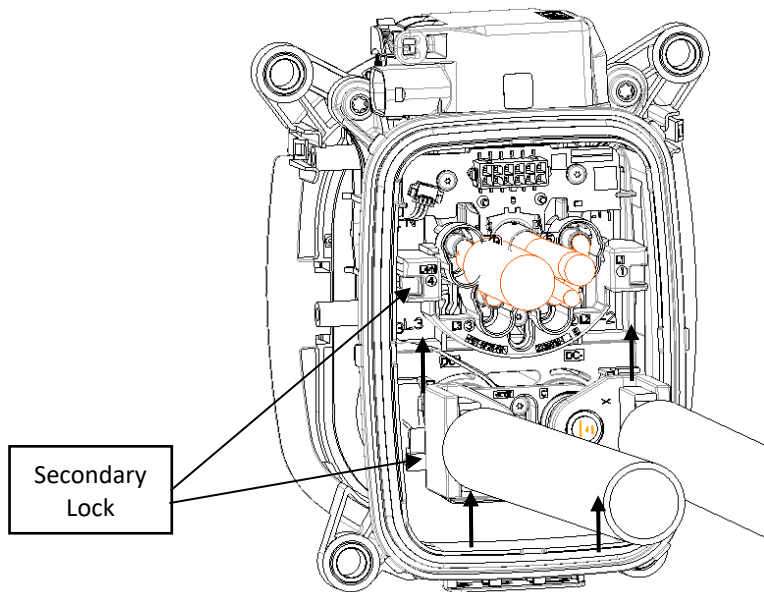

Figure 30

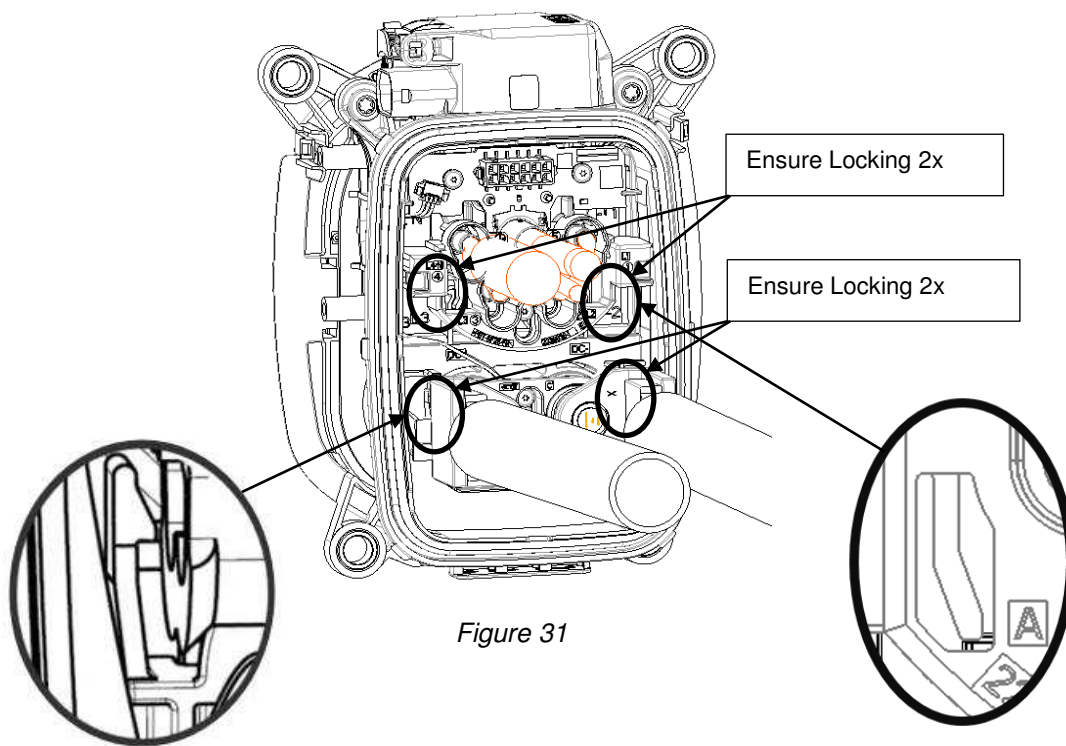

Figure 31

Figure 31a

Figure 31b

Step 13

Connect Micro Mate'N'Lock Connector to PCB-Header. Ensure the hook is properly engaged with the header, see Figure 32.

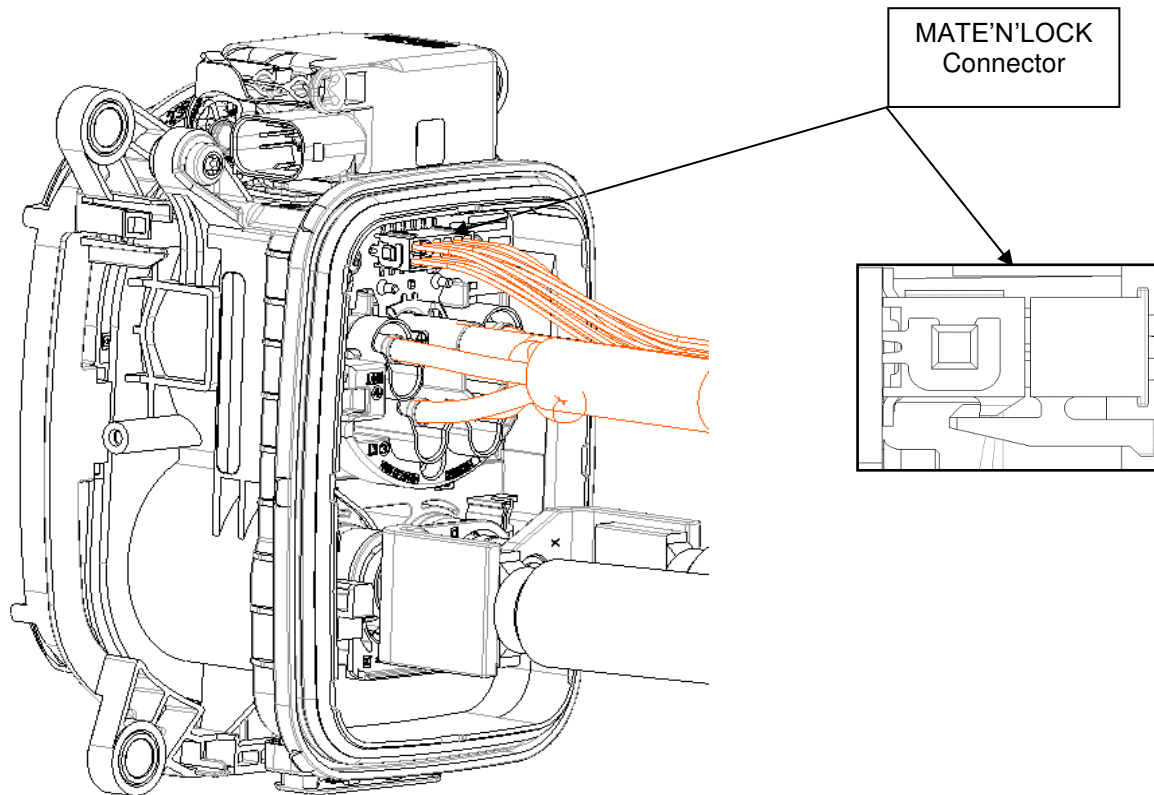

Figure 32

Step 14

Mount the CABLE EXIT COVER 2390858-1 w/o AC or 2390858-2 with AC to the CHARGE INLET HSG, COMBO 2, ASSY, 2401362. Ensure that all 6 hooks are correctly engaged. The press force must be applied on the marked locations close to the latches, see Figure 33.

ATTENTION: The CABLE EXIT COVER 2390858 needs to be aligned properly over the inlet and pushed vertically into position to make sure the seal slips correctly seated all around (Figure 33).

For the proper alignment, pay attention to the anti-rotation features implemented in the CABLE EXIT COVER 2390858-1 w/o AC or 2390858-2 with AC. So that the PIN, DIA8.0, WELDING 180 DEG, 2390840-1 orientations are dictated by those features. See orientation on Figure 33 and the anti-rotation features on Figure 33a and 33b illustrated.

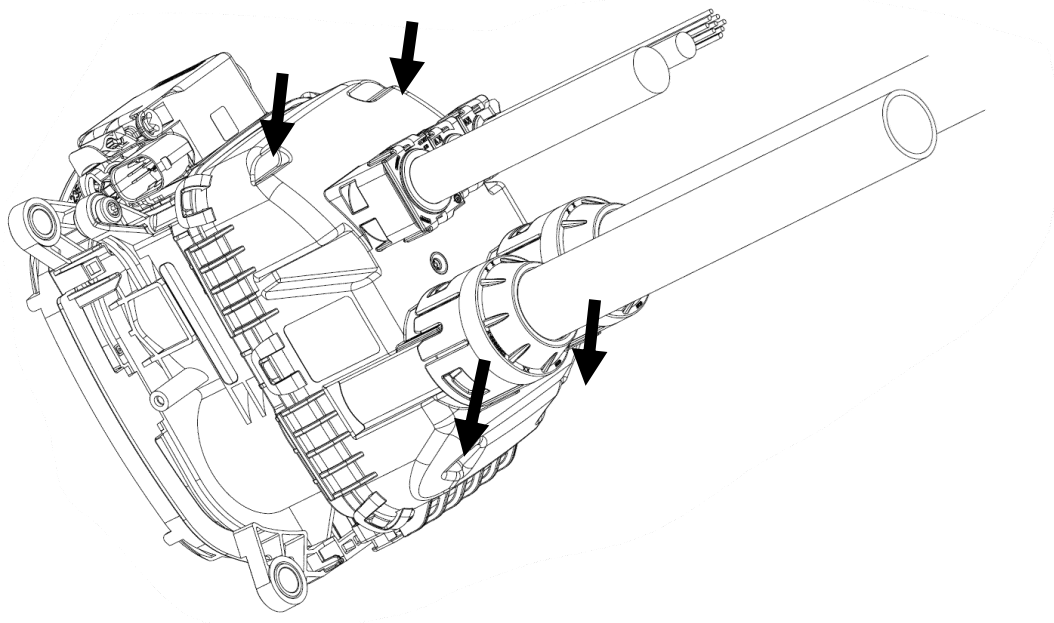

Figure 33

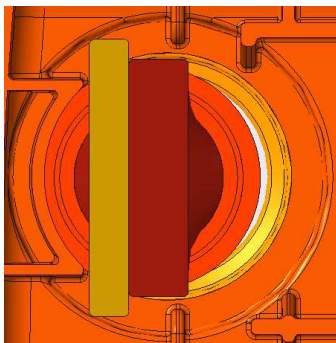

Figure 33a

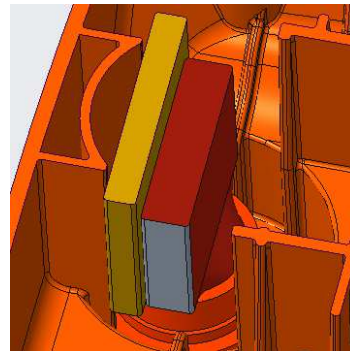

Figure 33b

ATTENTION: The Cable Exit Cover 2390858-1 and 2390858-2 needs to be aligned properly over the inlet and pushed vertically into position to make sure the seal slips correctly into the seating all around (Figure 34)

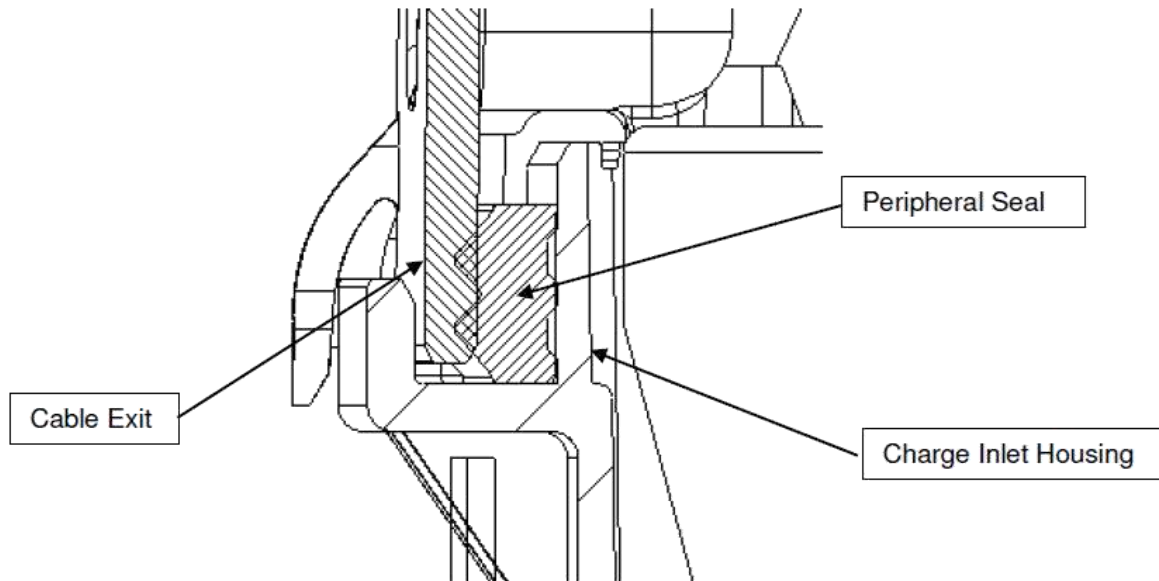



Figure 34

Step 15

Move the STRAIN RELIEF together with SEAL into their position in the CABLE EXIT WITH OUT AC 2390858-1 OR WITH AC 2390858-2, see Figure 35.

 **ATTENTION:** Ensure that the AC cable is well positioned in the SEAL, that all seal lips are safely placed on the outer isolation of the cables. (Figure 36a)

Push the AC, PE and SIGNAL COVER over it and snap it on the CABLE EXIT COVER WITHOUT AC 2390858-1 OR WITH AC 2390858-2. Ensure that both hooks are correctly engaged (double audible click), see Figure 36a.

Push the DC STRAIN RELIEF, DC SINGLE WIRE SEAL, into position in the CABLE EXIT, 95 SQMM, WITHOUT AC 2390858-1 OR WITH AC 2390858-2 and snap the CHARGE INLET HSG, DC SINGLE SEAL COVER on it. Ensure that all hooks are correctly engaged (audible click sound), see Figure 36b

ATTENTION: Ensure that the DC power cables are well positioned in the CHARGE INLET HSG, DC SINGLE WIRE SEAL, that all seal lips are safely placed on the outer isolation of the cables.

Place a CABLE TIE, (Black, 2.5 mm wide, 1mm thick, 100mm long, min. tensile strength: 80N) around the single wire signal cables and the bridge at the SIGNAL COVER and pull tight, see Figure 36a.

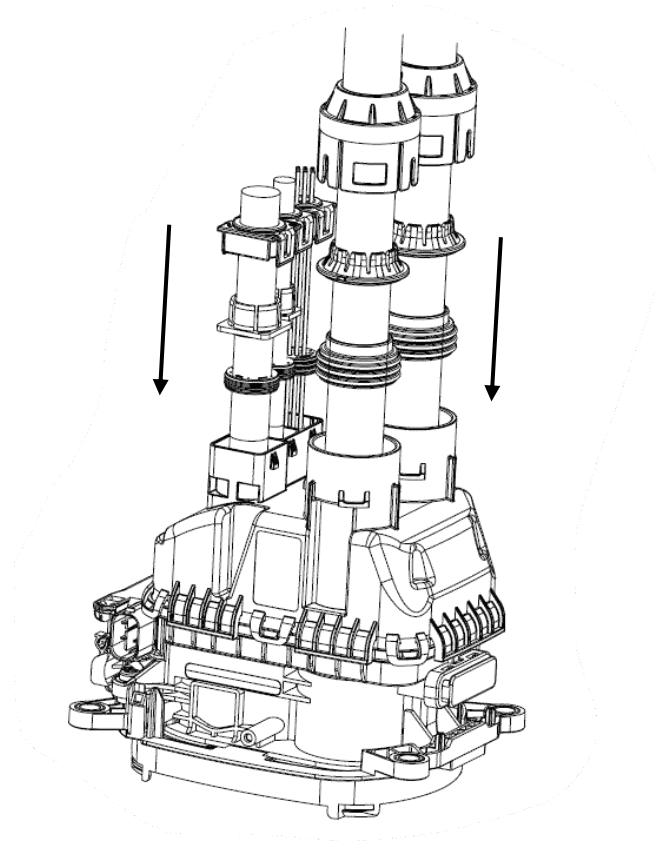

Figure 35

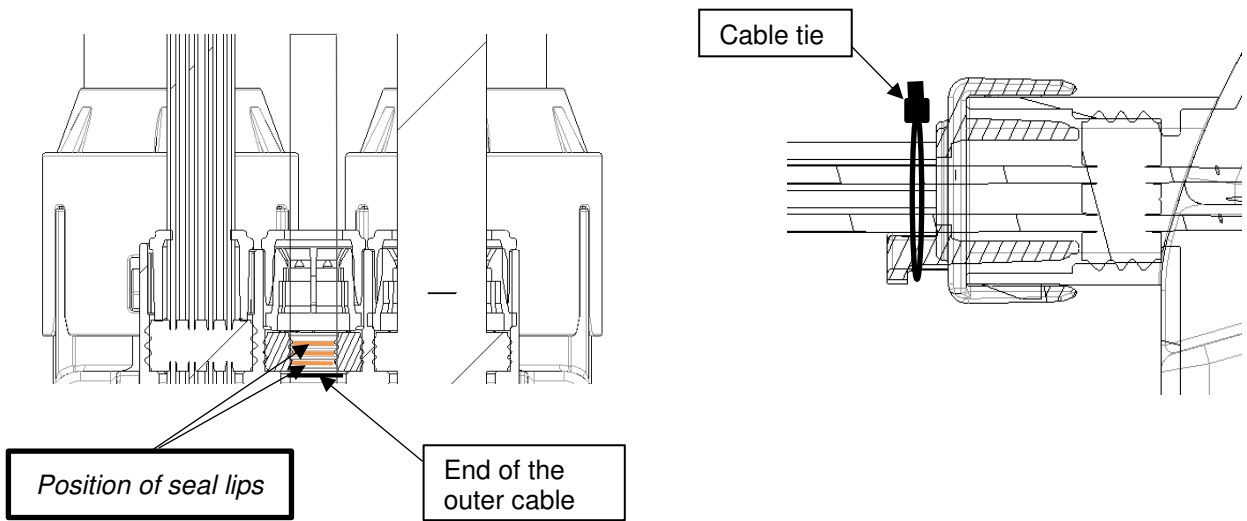

Figure 36a – AC seal lips

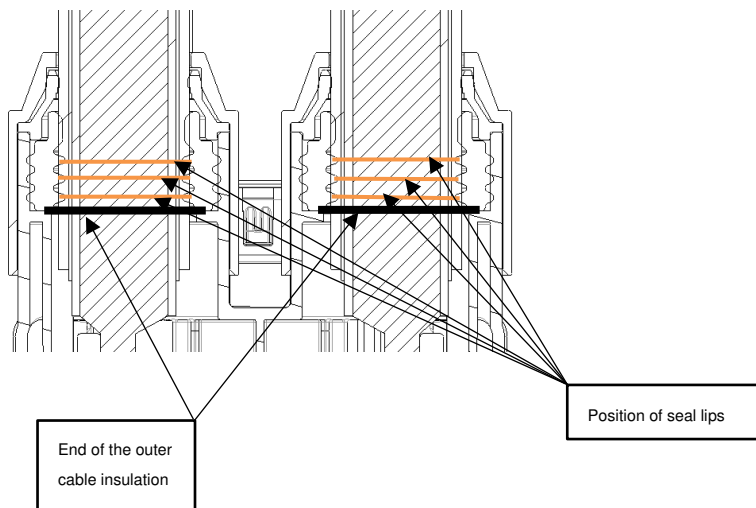

Figure 36b – DC seal lips

Step 16

Assemble Protection Cap 2292534-1 at Inlet Housing, see Figure 37.

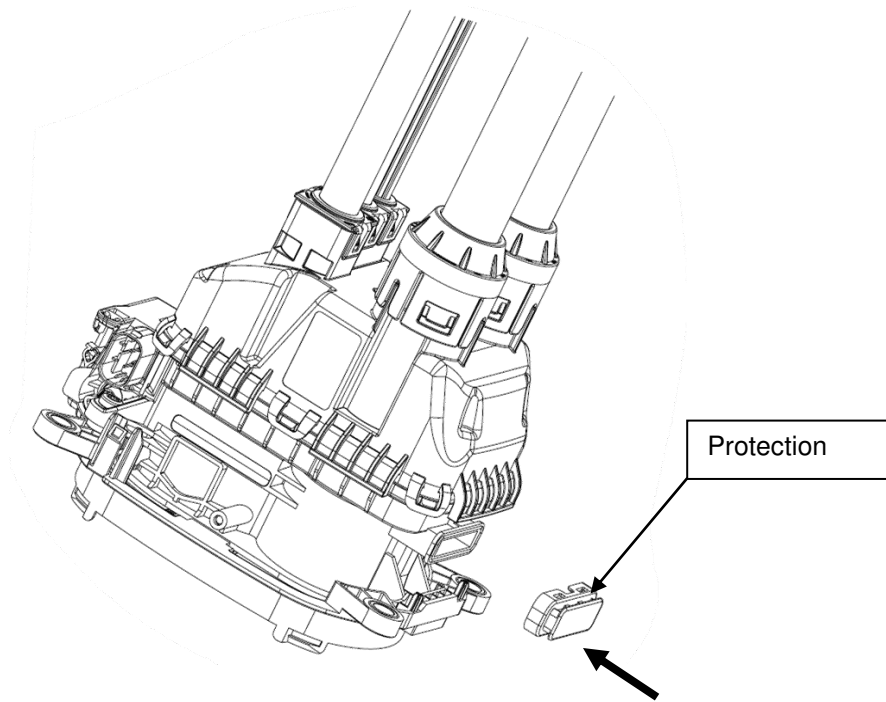

Figure 37

Step 17

As part of the End of Line Test as listed in (Chapter 7.7), perform the tightness check of the fully assembled charge inlet. The pressure port on the rear of CABLE EXIT COVER 2390858-1 or 2390858-2 (shown in Figure 38) is designed to fit an elastic plastic tube (Polyurethane or similar) with an outer diameter of 4mm.

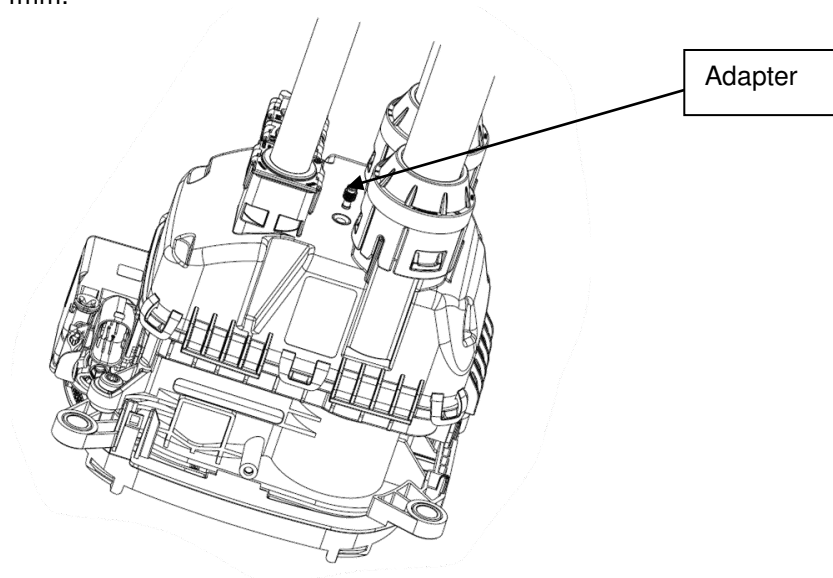

Figure 38

The tubular geometry of the pressure port has a reduced inner diameter towards the bottom to increase the pressure on the elastic tube when being inserted. The tube needs to be pushed that far into the pressure port that a reliable sufficient air tightness can be achieved, see Figure 39 for exemplarily inserted tube.

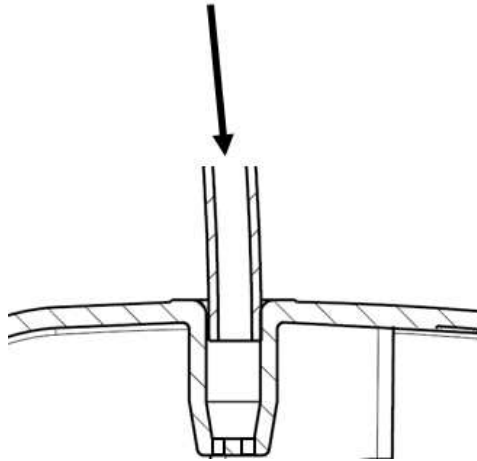

Figure 39

For the tightness check it is intended to perform an air differential pressure decay leak measurement test. Pressure profile is 0,1...0,15 bar, preferably under pressure. Acceptance criterion is pressure loss over time and has to be defined based on particularly prepared failure test samples

After successfully passed tightness check the pressure port needs to be closed with the MQS CAVITY PLUG 963143-1

The MQS CAVITY PLUG needs to be FULLY inserted into the pressure port, see Figure 40. The bottom of the pressure port is closed with a cross geometry to avoid that the MQS Cavity Plug could be pushed through.

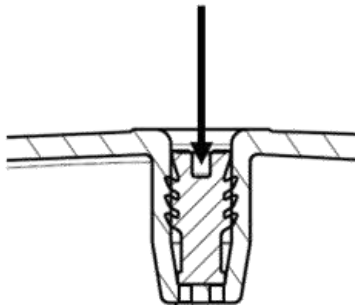

Figure 40

Step 18**Assembly of 4pos MQS connector**

Assemble the Connector for the Actuator connection acc. to application spec of MQS-Connector. (Applicator 2151038; Die Set 5-1579001-1).

Push connector on actuator housing. To ensure that the connector is correctly inserted, pull and push with a low force on the housing (max. 10N).

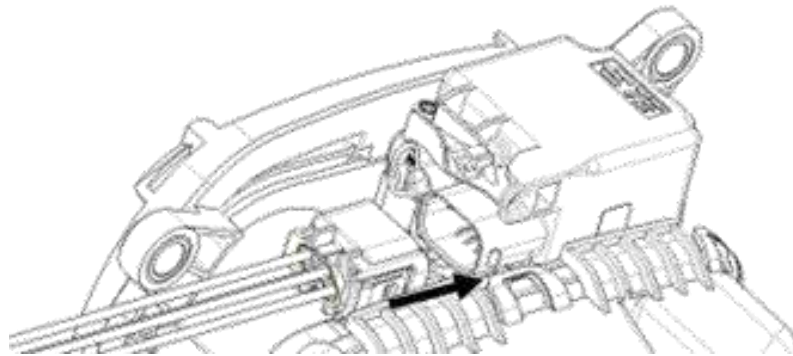

Figure 41

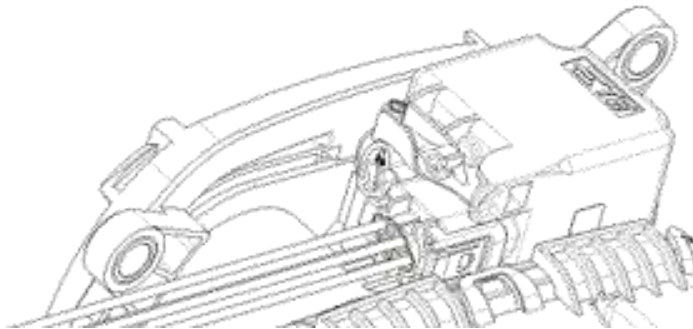

Figure 41a

7.7 End of Line Test



ATTENTION: The assembled Charge Inlet must be tested electrically and mechanically to applicable requirements, including High Voltage test.

As a minimum, following tests have to be performed:

- Isolation Resistance:
 Test Voltage: 500VDC
 Inspection Duration: 1s
 min. Riso: 200MΩm
 pin-to-pin, excluding CP-to-Proxi and CP/Proxi-to-Ground
 - a) L1, L2, L3 and N versus PE
 - b) L1 versus L2
 - c) L2 versus L3
 - d) L3 versus N
 - e) L1, L2, L3 and N versus AC multicore shield
 - f) DC+ versus DC-

- Di electric withstand voltage:
 Test Voltage: 2000VAC
 Inspection Duration: 1s
 max. Leakage current: 10mA
 pin-to-pin, excluding CP-to-Proxi and CP/Proxi-to-Ground
 - a) L1, L2, L3 and N versus PE
 - b) L1 versus L2
 - c) L1 versus L3
 - d) L1 versus N
 - e) L2 versus L3
 - f) L2 versus N
 - g) L3 versus N
 - h) L1, L2, L3 and N versus AC multicore shield
 - i) DC+ versus DC-
 - j) DC+ and DC- versus HV cable shield

- Correct Pinning of all Contacts
- Check seals for correct seating by Tightness Check of completed Charge Inlet Harness Assy (Air pressure test)
- Check correct assembled MQS Cavity Plug in the pressure port after Tightness Check.
- Functionality checks of actuator. Drive (first) in lock and (second) in unlock position. During this operation, the actuator pull ring / pull cable becomes pulled back in end position.
- For LED versions only below, test is followed:

Test Item	TEST VOLTAGE		GROUND PIN	PROPERTY @T _{amb} = 25° ± 5° C	
	VALUE	PIN		LIGHT EMISSION	CURRENT
LED WHITE	11V ± 0.2V	5	4	WHITE	20mA + 4mA
LED GREEN	11V ± 0.2V	1	4	GREEN	20mA + 4mA
LED RED	11V ± 0.2V	2	4	RED	20mA + 4mA

Table 9

8 TORQUE VALUE FOR M6 SCREWS

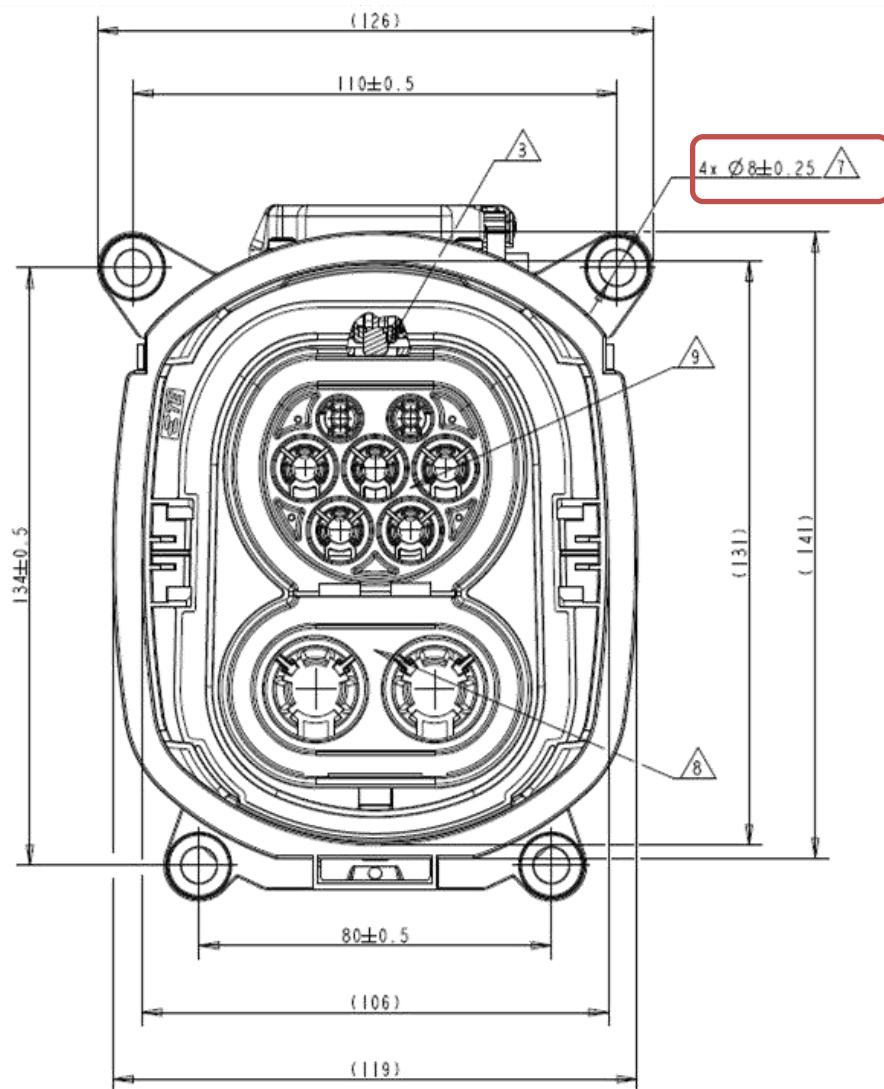

Figure 42

 APPLICABLE SCREWS FOR MOUNTING, HEAD DIAMETER MIN. 10.5mm,
TORQUE 6Nm±0.9Nm FOR M6 SCREWS

In the above Figure 42 shows the necessary torque 6Nm±0.9 NM for M6 screws required to maintain in all 4 mounting hole positions.

9 MINIMUM LENGTH FOR CABLE FIXATION

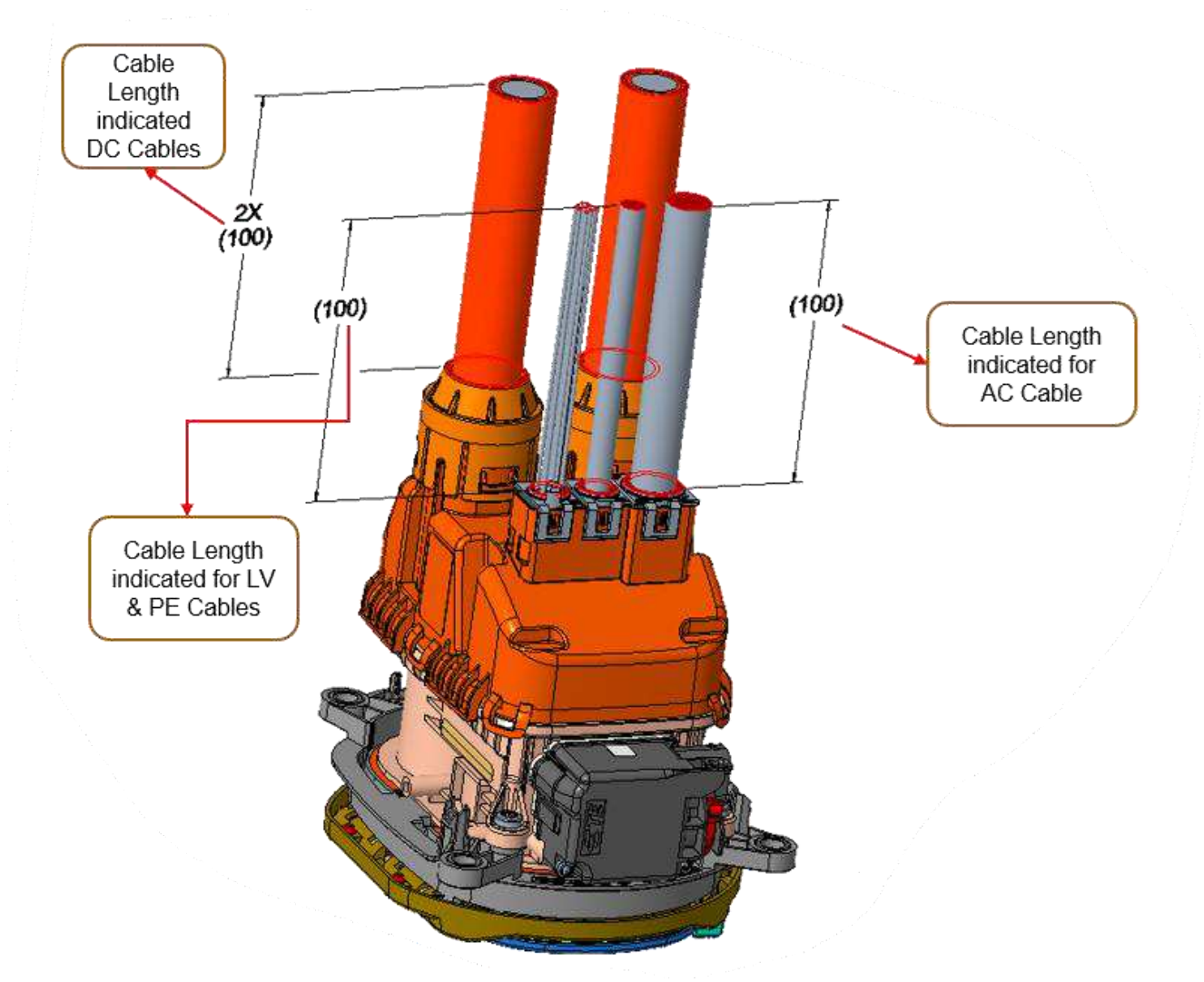

Figure 43

As per mentioned in the Figure 43 preferred free length of cables to be within a distance of 100mm exiting from cable covers.

LTR	REVISION RECORD	DWN	APVD	DATE
1	INITIAL DOCUMENT	SUPRIYA S	KASHYAP P B	21 DECEMBER 2023
A	INITIAL DOCUMENT	SUPRIYA S	KASHYAP P B	1 FEBRUARY 2024
A1	24V ACTUATOR VARIANTS ADDED	AJITH JAMES	KASHYAP P B	13 FEBRUARY 2024

DWN SUPRIYA S		TE CONNECTIVITY GERMANY GMBH AMPÈRESTRASSE 12-14 D-64625 BENSHEIM CHK GERMANY		
CHK AMRUTHA RAO C H				
APVD KASHYAP P B		NO 114-94810	REV A	LOC AI
TITLE	Application Specification Vehicle Charge Inlet Type CCS2 95mm2			