

PROPER USE GUIDELINES

Cumulative Trauma Disorders can result from the prolonged use of manually powered hand tools. Hand tools are intended for occasional use and low volume applications. A wide selection of powered application equipment for extended-use, production operations is available.

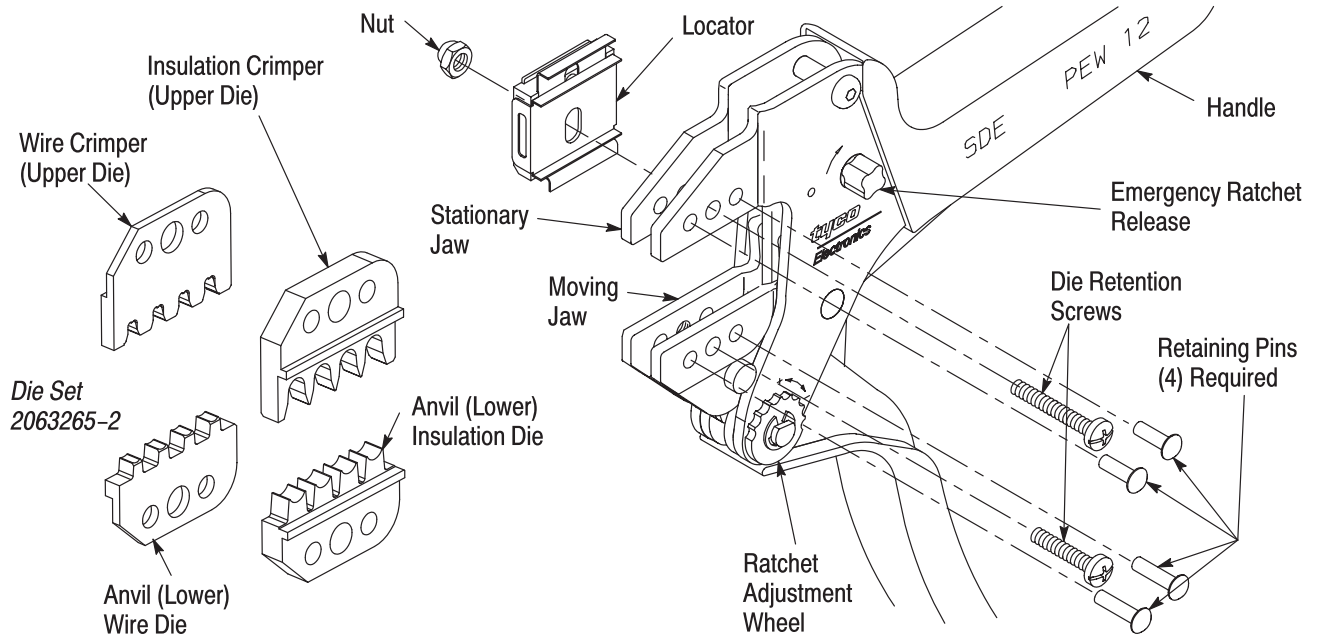

DIE ASSEMBLY	CONTACTS	WIRE SIZE mm ² [AWG]	INSULATION DIA	STRIP LENGTH
2063265-2	963905 963711	0.75 [18.5]	1.70-1.90 [.067-.075]	3.5-4.1 [.138-.161]
	963713		1.90-2.10 [.075-.083]	
	963903	0.50	1.40-1.60 [.055-.063]	3.2-3.8 [.126-.150]
	963710 963712	0.35	1.20-1.40 [.047-.055]	

Figure 1

1. INTRODUCTION

SDE PEW-12 Hand Tool Assembly 2063265-1 consists of SDE PEW-12 Frame Assembly 9-1478240-0 and die set assembly 2063265-2. See Figure 1. The tool is used to crimp Micro Timer 2+3 Contacts.



Dimensions in this instruction sheet are in millimeters [with inches in brackets]. Figures and illustrations are for reference only and are not drawn to scale.

The tool features a ratchet and an adjustment wheel with a range of settings. The ratchet ensures that the tool has completed the cycle and will not release until the handles have been FULLY closed, unless the emergency ratchet release is rotated to manually release the ratchet. The adjustment wheel controls the amount of handle pressure exerted on the dies during the crimping procedure.



The dies bottom before the ratchet releases. This feature ensures maximum tensile performance of the crimp. DO NOT re-adjust the ratchet.

2. DESCRIPTION

The tool frame features two jaws, a handle, ratchet adjustment wheel, and an emergency ratchet release. The die set consists of an indenter (upper die) and an anvil (lower die). The tool frame holds a die assembly with two crimping chambers. See Figure 1. Die retaining pins and die retaining screws are used to position and secure the dies in the tool frame.

3. INSTALLATION AND REMOVAL OF DIE SET AND LOCATOR ASSEMBLY (Figure 1)

1. Open the tool handles and remove the two die retaining screws from the tool jaws.
2. Place the wire anvil and insulation anvil so that their chamfered sides and their marked surfaces face outward, when mounted in the moving jaw of the tool frame.

3. Insert the two die retaining pins.
4. Insert the short die retaining screw through the jaw and through both anvil dies, and tighten the screw just enough to hold the dies in place. Do *not* tighten the screw completely at this time.
5. Place the wire crimper and insulation crimper so that their chamfered sides and their marked surfaces face outward, when mounted in the stationary jaw of the tool frame.
6. Insert the two die retaining pins.
7. Insert the long die retaining screw through the jaw and through both crimper dies, and tighten the screw just enough to hold the dies in place. Do *not* tighten the screw completely at this time.
8. Carefully close the tool handles, making sure that the anvils and crimpers align properly. Continue closing the tool handles until the ratchet in the tool frame has engaged sufficiently to hold the anvils and crimpers in place, then tighten both die retaining screws.
9. Place the locator assembly over the end of the long screw, and position the locator assembly against the side of the tool jaw.
10. Place the nut onto the end of the long screw and tighten the nut enough to hold the locator assembly in place, while still allowing the locator to slide up and down.
11. To disassemble, close the tool handles until the ratchet releases, remove the nut, the locator assembly, the two die retaining screws, and the four die retaining pins, and slide the anvils and crimpers out of the tool jaws.



The ratchet has detents with audible “clicks” as the handles are closed. The ratchet releases on the sixth “click”.

4. CONTACT SUPPORT ADJUSTMENT (Figure 2)



The contact support is preset prior to shipment, but minor adjustment may be necessary.

1. Make a sample crimp and determine if the contact is straight, bending upward, or bending downward.
2. If adjustment is required, loosen the screw that holds the contact support onto the locator assembly.



The ratchet has detents that create audible clicks as the tool handles are closed.

3. Place a contact with wire into the proper nest and close the tool handles until the ratchet reaches the sixth click, or until the contact support touches the contact.
4. Slightly loosen the nut that holds the locator assembly onto the tool frame.
5. Move the contact support as required to eliminate the bending of the contact.
6. Tighten the nut and close the handles until the ratchet releases.
7. Remove and inspect the contact.
8. Make another sample crimp. If the contact is straight, tighten the contact support screw. If the contact is still being bent during crimping, repeat the adjustment procedure.

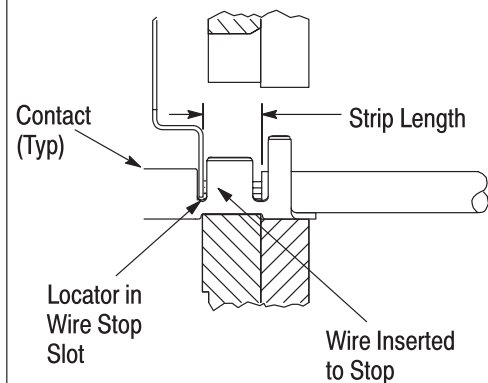
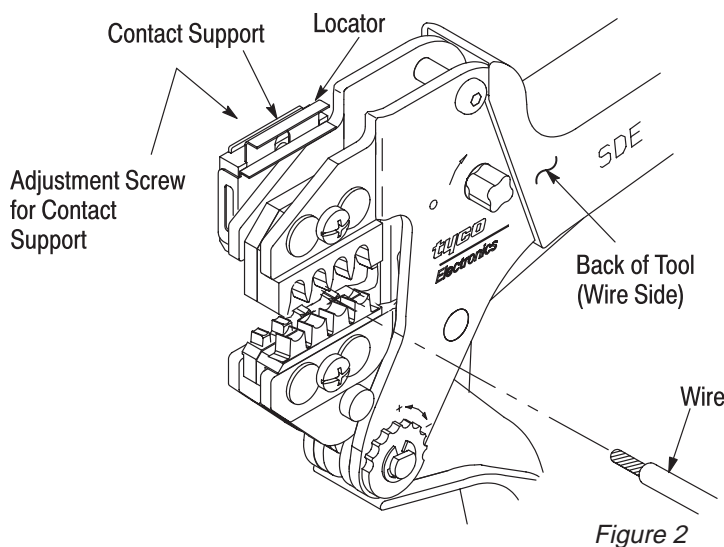

Figure 2

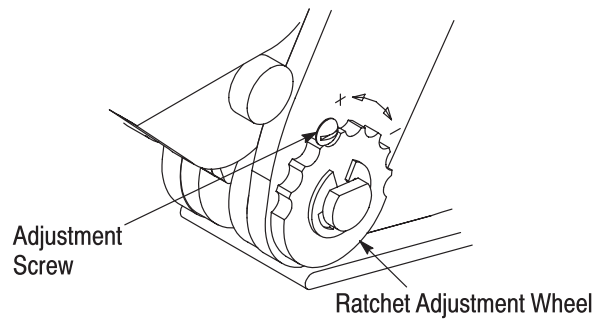

Figure 4

8. MAINTENANCE AND INSPECTION

8.1. Daily Maintenance

1. Remove dust, moisture, and other contaminants with a clean, soft brush, or a clean, soft, lint-free cloth. **DO NOT** use any objects that could damage the dies or tool.
2. Make sure that the proper die retaining screws are properly secured.
3. When the tool is not in use, keep the handles closed to prevent objects from becoming lodged in the dies. Store the tool in a clean, dry area.

4. Remove all lubrication and accumulated film from the dies by immersing the dies in a suitable commercial degreaser.

8.2. Inspection

1. Close the tool handles until the ratchet releases, and then allow them to quickly open freely. If they do not open quickly and fully, the spring is defective. See Section 9, REPLACEMENT.
2. Inspect the crimping surfaces of the dies for flattened, chipped, worn, or cracked areas. If damage is evident, the dies must be replaced. Refer to Section 9, REPLACEMENT.

9. REPLACEMENT

Order replacements through your representative, or call 1-800-526-5142, or send a facsimile of your purchase order to 717-986-7605, or write to:

CUSTOMER SERVICE (038-035)
 TYCO ELECTRONICS CORPORATION
 P.O. BOX 3608
 HARRISBURG, PA 17105-3608

10. REVISION SUMMARY

- Initial release of document

2063265-2 Die Set can be Used in Tools Show Below

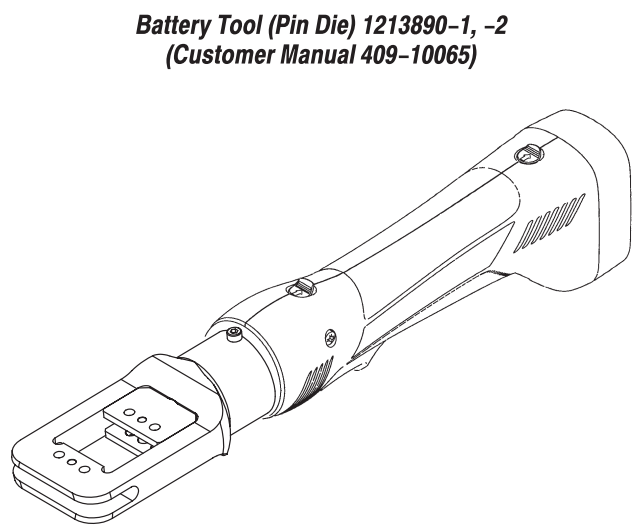
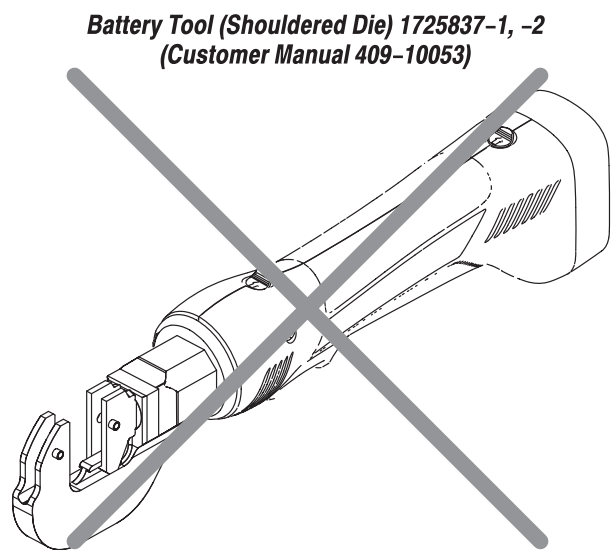
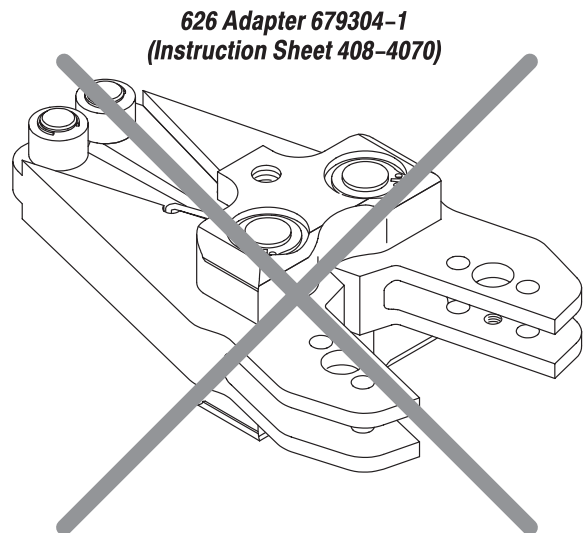
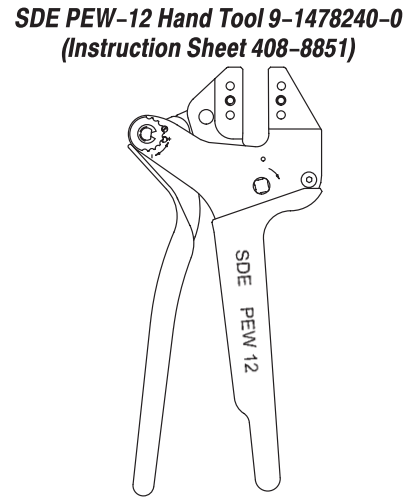

Figure 5