

Figure 1

1. INTRODUCTION

This instruction sheet provides information on the assembly and installation of the HVA280 3-Position Header Assembly to a device. It also provides instructions regarding the mating and unmating of the header assembly with the mating HVA280 3-Position Plug Assembly.

NOTE



All dimensions on this document are in metric units. Figures and illustrations are for reference only and are not drawn to scale.

Read these instructions carefully before attempting any assembly procedures.

NOTE



Header assembly 1587727 shown in most figures, however 2103200 and plastic header 1587973 have same assembly requirements.

Refer to Section 8, REVISION SUMMARY for reason for revision.

2. COMPONENTS

Figure 1 provides the components required to make the assembly in this instruction sheet. The header assembly must be mounted to a device housing to complete the installation sequence.

3. TOOLING

Tools which are required for crimping the blade contacts in this assembly are listed in Application Specification 114-18051.

4. ASSEMBLY

The following procedure shows the details of the header installation onto a device and the terminal insertion into the header assembly.

1. Note the polarization feature located on the back side of the header as shown in Figure 2.

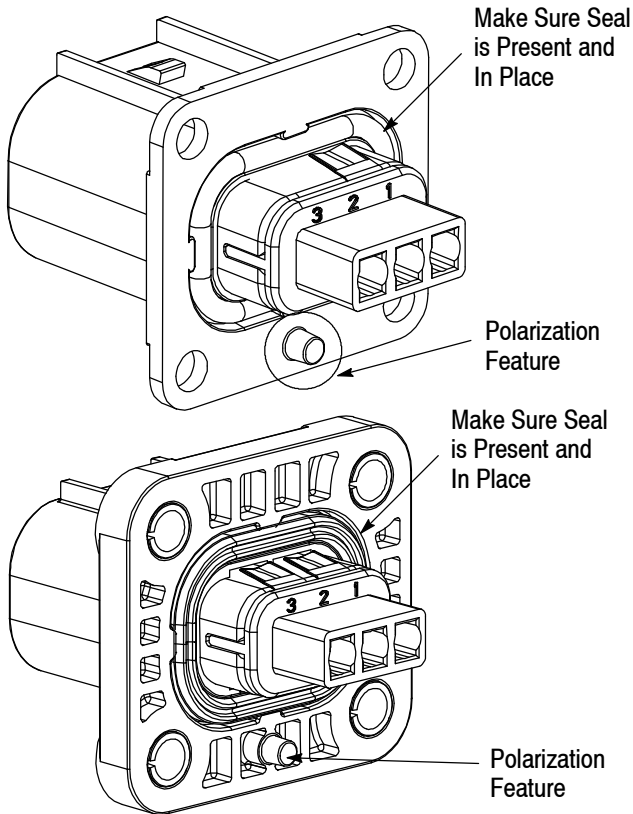

Figure 2

2. Install the header assembly into the device mounting interface by aligning the header polarization feature and pushing the header into the mounting hole by hand (see Figure 3) until the header is seated against the face of the device as shown in Figure 4.

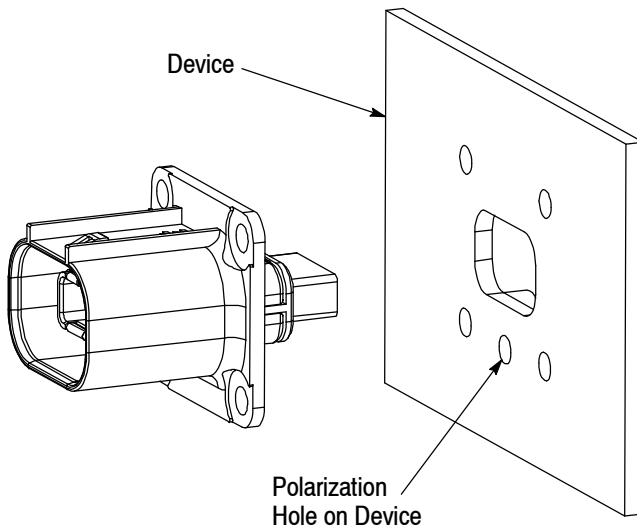
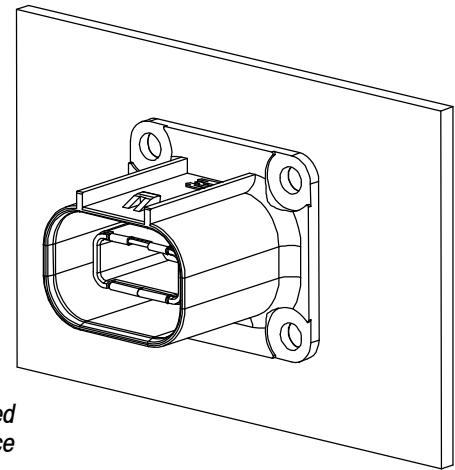

Figure 3



Header Seated Against Device

Figure 4

NOTE



See Customer Drawing C-1587727, C-2103200 or C-1587973 for mounting interface definition and requirements.

3. Secure the header with four M4 fasteners through the flange mounting holes as shown in Figure 5. Torque all fasteners to $2.5 \pm 1\text{Nm}$. The user must ensure that the device and fasteners are compatible and capable of meeting the above torque requirements.

NOTE



See Customer Drawing C-1587727, C-2103200 or C-1587973 for mounting fastener clearance requirements.

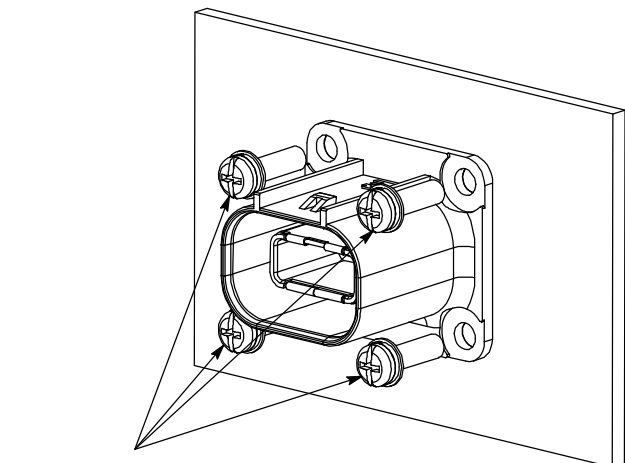

Secure Header with Four M4 Fasteners

Figure 5

4. Prepare the crimped leads according to the terminal Application Specification 114-18051 for the terminals listed. Only wire that meets this

specification can be used. Note that the header will only accept the terminals listed. Other versions may not install correctly. Also note that the silver plated terminals must be used for high-voltage operation.

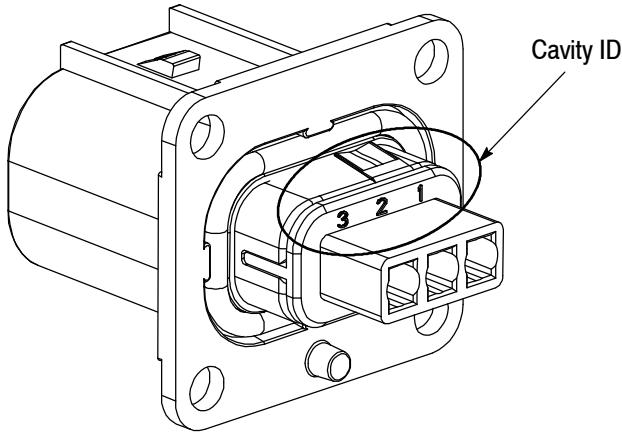

Figure 6

5. Note the cavity number on the cable entry end of the header. See Figure 6. Insert the blade contacts into the header inner housing until they are fully locked as shown in Figure 7. Verify that the contact is completely inserted as shown in Figure 8 by gently pulling back on the conductor.

The conductor is now ready for use in its intended application.

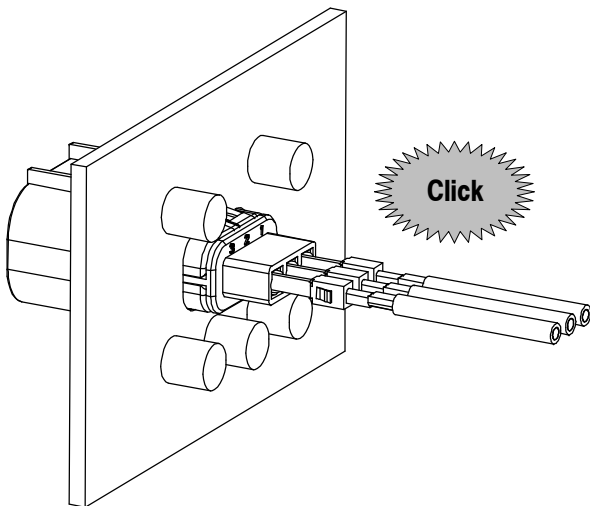

Figure 7

6. *Optional:* Assemble the shipping cap 1587733-1 onto the header assembly until it fully locks to the outer housing as shown in Figure 9. Shipping cap cannot be used with 2103200-[].

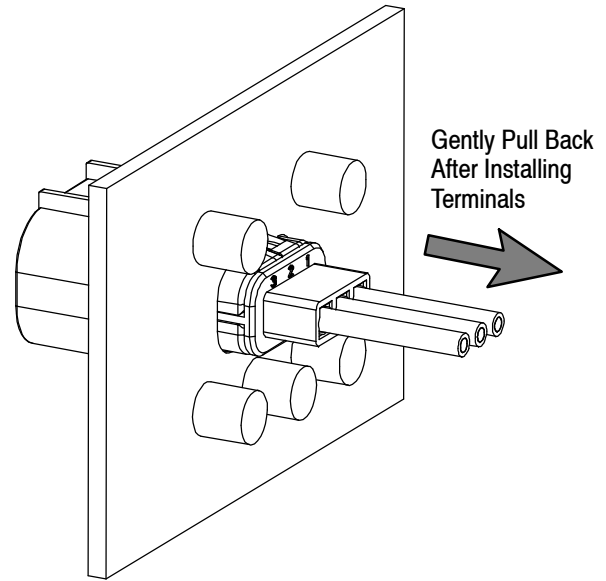





Figure 8

NOTE  The shipping cap is not intended to provide protection from liquid of any type. It is only intended to protect the terminals from getting damaged or touched during shipping.

5. CONTACT PROBING

CAUTION  Contact probing is not recommended on the header due to the possible presence of high-voltage. If continuity checks need to be done, the user must ensure the high-voltage is disabled.

CAUTION  Avoid probing the contact in an area that could damage the plating on the blade contact surface. The best location for probing the blade contact is at the front edge of the blade using a probe tip of 1.6 mm diameter or bigger.

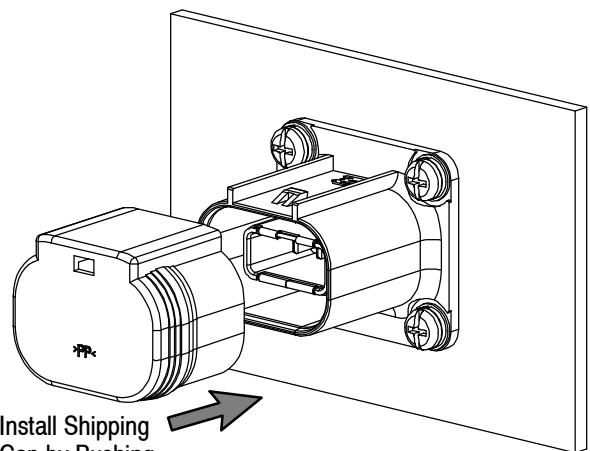

Figure 9

6. CONNECTOR MATING

The following procedures provide steps to mate the high-voltage plug assembly and header assembly. See Figure 10.

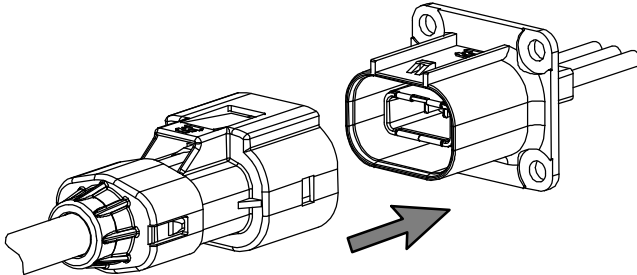
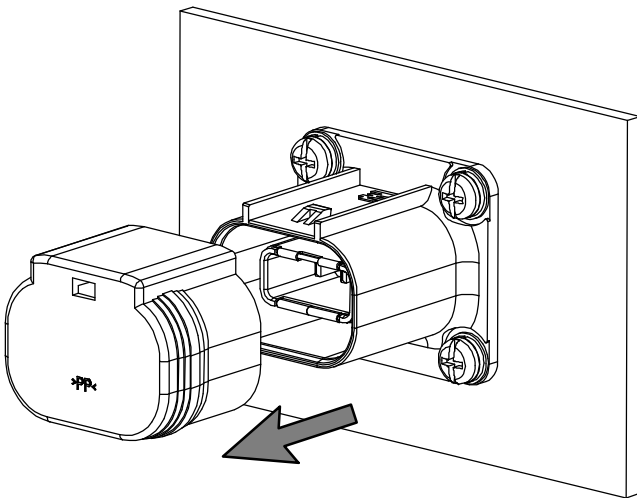

Figure 10

1. Prior to mating the corresponding plug with the header, remove the shipping cap (if installed) by pulling the shipping cap away from the header until it comes off. See Figure 11. Discard the shipping cap in a safe manner.



Remove Shipping Cap by Pulling Cap Off of Header Housing

Figure 11

2. Push the HVA280 plug assembly and header assembly together until the main latch engages with a click. See Figure 12. If the connector halves do not fit together easily, check the following:

- Keying options on the HVA280 plug assembly matches the HVA280 header assembly.

- HVA280 plug and header assemblies are correctly oriented (180°).

Pull lightly on the HVA280 plug assembly to verify that the plug and header are fully latched. The connector system is now fully functional.

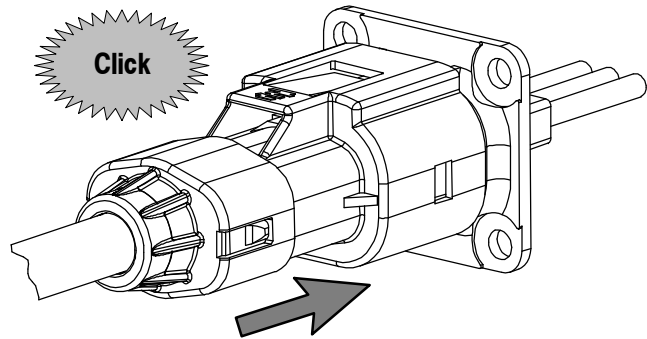

Figure 12

7. CONNECTOR UNMATING

DANGER



User must exercise extreme caution to verify high-voltage power is disabled before unmating the header and plug.

The following procedures provide steps to unmate the high-voltage plug assembly and header assembly.

1. Push a flat-bladed screwdriver straight into the latch opening in the back of the plug assembly. The screwdriver will act as a wedge between the latch and the HVA280 plug assembly and the latch retention feature of the HVA280 header. Do NOT pry the latch.
2. At the same time, pull the HVA280 plug assembly and header apart as shown in Figure 13. Do NOT pull on the cable or cable seal retainer.
3. The plug and header assemblies are now disconnected.

8. REVISION SUMMARY

- Updated document to incorporate requirements
- Added new artwork to Figures 1 and 2
- Added new NOTE to Section 1, INTRODUCTION
- Added new text to NOTES in Paragraphs 4.2 and 4.3

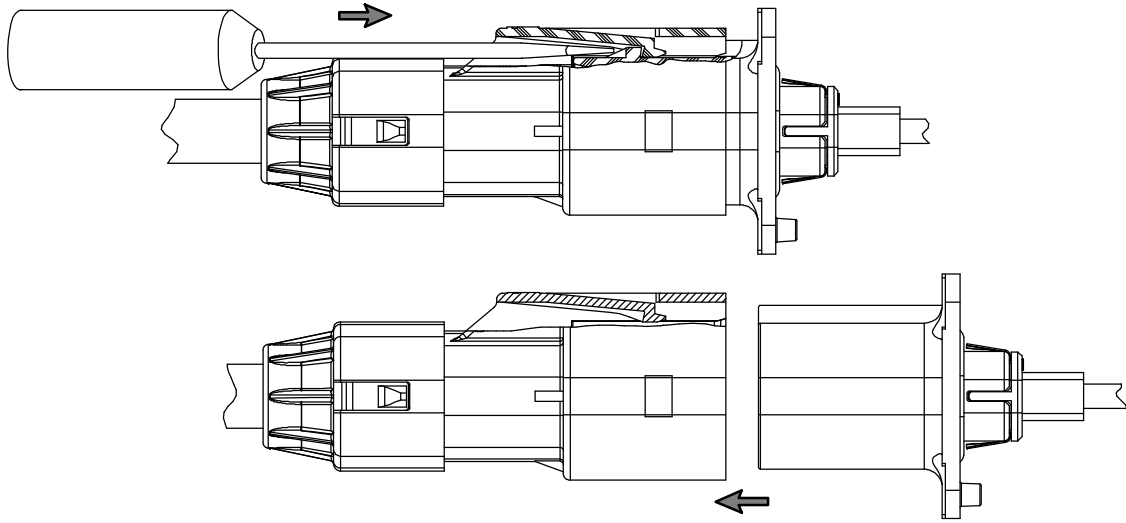

Figure 13