



**NOTE**

All numerical values are in metric units [with U.S. customary units in brackets]. Dimensions are in millimeters [and inches]. Unless otherwise specified, dimensions have a tolerance of  $\pm 0.13$  [ $\pm .005$ ] and angles have a tolerance of  $\pm 2^\circ$ . Figures and illustrations are for identification only and are not drawn to scale.

## 1. INTRODUCTION

This instruction sheet covers the use of the Power Versa-Lock connector system. Instructions for contact and housing assembly procedures and seal assembly procedures are included. Application Specification 114-143082 provides the requirements for application, including wire size range, contact crimp requirements.



**NOTE**

Contact the TE Product Information Center at the number at the bottom of page 1 for product availability.

## 2. CONNECTOR ASSEMBLY

### 2.1. Sealed Applications

#### A. Cap (Panel Mount)

Configurations for sealed panel mount cap applications are shown in Figure 1.

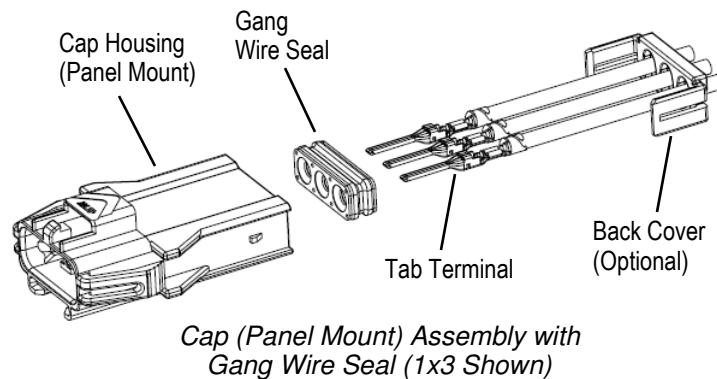

**NOTE**

- (a) See Customer Drawing for applicable housing dash number based on color and keying configuration.
- (b) See Application Specification 114-143082 for wire sizes, insulation diameter ranges, and crimping information for terminals. For 2 row housings, terminals in the top row must be inverted  $180^\circ$  from terminals in the bottom row. For 3x3 configurations no terminal inversion from row to row is required.
- (c) Assembly requires two gang seals in 2x3 sealed panel mount cap configurations and three gang seals for 3x3 sealed configurations. See Customer Drawing for applicable seal dash number based on wire insulation diameter and number of positions.

**Figure 1**

### B. Cap (Twist-N-Lock)

Configurations for sealed Twist-N-Lock cap applications are show in Figure 2.

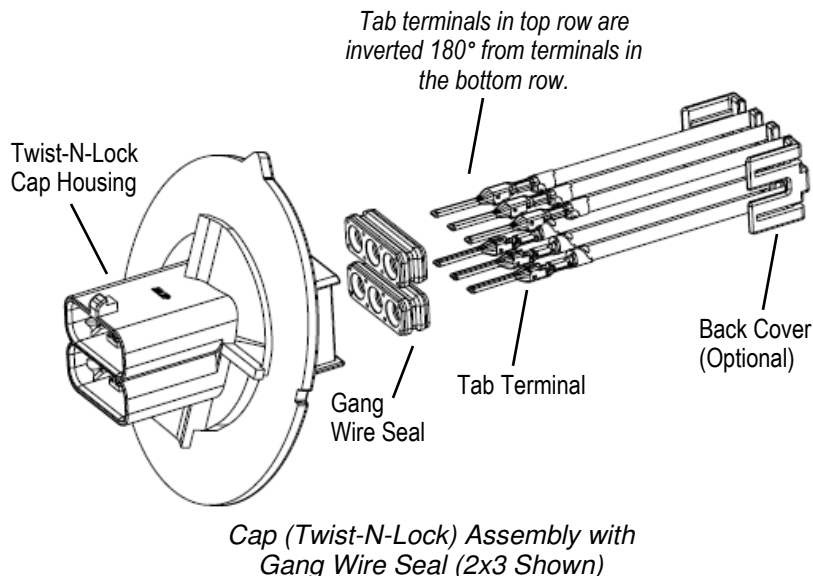

**NOTE**

- (a) See Customer Drawing for applicable housing dash number based on color and keying configuration.
- (b) See Application Specification 114-143082 for wire sizes, insulation diameter ranges, and crimping information for terminals. For 2 row housings, terminals in the top row must be inverted 180° from terminals in the bottom row. For 3x3 configurations no terminal inversion from row to row is required.
- (c) Assembly requires two gang seals in 2x3 sealed Twist-N-Lock cap applications and three gang seals for 3x3 sealed configurations. See Customer Drawing for applicable seal dash number based on wire insulation diameter and number of positions.

**Figure 2**

### C. Cap (Free Hanging)

Configurations for sealed free hanging cap applications are shown in Figure 3.

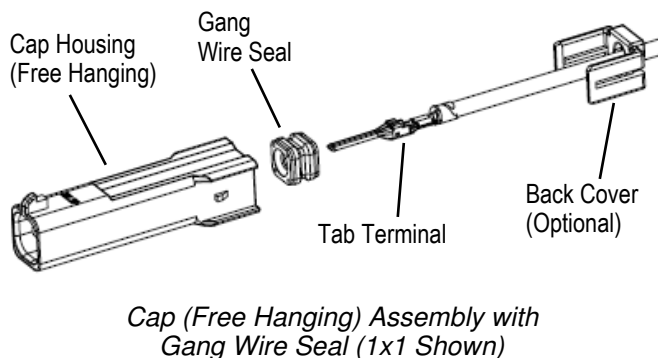

**NOTE**

- (a) See Customer Drawing for applicable housing dash number based on color and keying configuration.
- (b) See Application Specification 114-143082 for wire sizes, insulation diameter ranges, and crimping information for terminals.
- (c) See Customer Drawing for applicable seal dash number based on insulation diameter range.

**Figure 3**

### D. Plug

Configurations for sealed plug applications are shown in Figure 4.

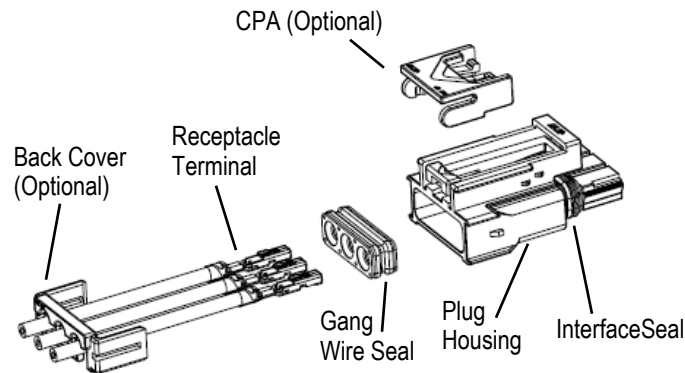

*Plug Assembly with Gang Wire Seals (1x3 Shown)*



**NOTE**

- (a) See Customer Drawing for applicable housing dash number based on color and keying configuration.
- (b) See Application Specification 114-143082 for wire sizes, insulation diameter ranges, and crimping information for terminals. For 2 row housings, terminals in the top row must be inverted 180° from terminals in the bottom row. For 3x3 configurations no terminal inversion from row to row is required.
- (c) See Customer Drawing for applicable seal dash number based on wire insulation diameter and number of positions.
- (d) Assembly requires two gang seals and two interface seals in 2x3 sealed plug configurations and three gang seals and three interface seals for 3x3 sealed plug configurations.

**Figure 4**

## 2.2. Unsealed Applications

### A. Cap (Panel Mount)

Configurations for unsealed panel mount cap applications are shown in Figure 5.

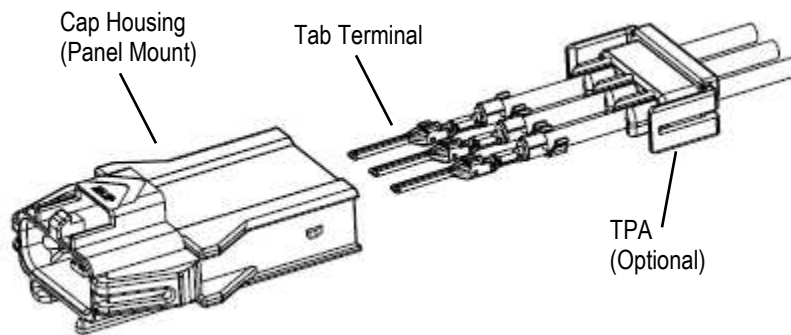

*Cap (Panel Mount) Assembly Unsealed Configuration (1x3 Shown)*



**NOTE**

- (a) See Customer Drawing for applicable housing dash number based on color and keying configuration.
- (b) See Application Specification 114-143082 for wire sizes, insulation diameter ranges, and crimping information for terminals. For 2 row housings, terminals in the top row must be inverted 180° from terminals in the bottom row. For 3x3 configurations no terminal inversion from row to row is required.

**Figure 5**

### B. Cap (Twist-N-Lock)

Configurations for unsealed Twist-N-Lock cap applications are shown in Figure 6.

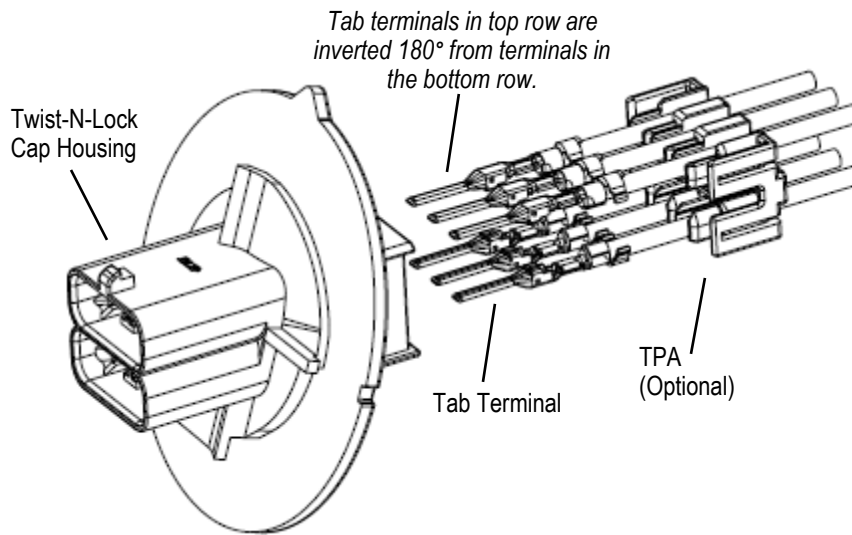

*Cap (Twist-N-Lock) Assembly Unsealed Configuration (2x3 Shown)*



**NOTE**

- (a) See Customer Drawing for applicable housing dash number based on color and keying configuration.
- (b) See Application Specification 114-143082 for wire sizes, insulation diameter ranges, and crimping information for terminals.
- (c) For 3x3 configurations no terminal inversion from row to row is required.

**Figure 6**

### C. Plug

Configurations for unsealed plug applications are shown in Figure 7.

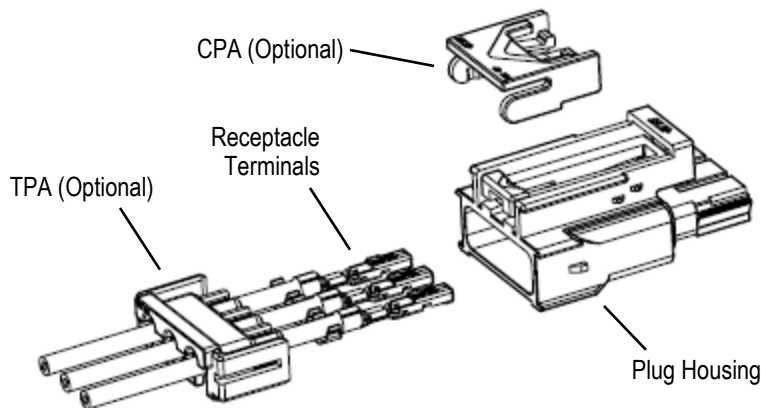

*Plug Assembly in Unsealed Application (1x4 Shown)*



**NOTE**

- (a) See Customer Drawing for applicable housing dash number based on color and keying configuration.
- (b) See Application Specification 114-143082 for wire sizes, insulation diameter ranges, and crimping information for terminals.

**Figure 7**

### 3. SEAL ASSEMBLY PROCEDURE

#### 3.1. Interface Seal Assembly

1. Assemble interface seal over contact silos of the plug housing as shown in Figure 8 until it rests against the mating face of the plug housing as shown in Figure 9.

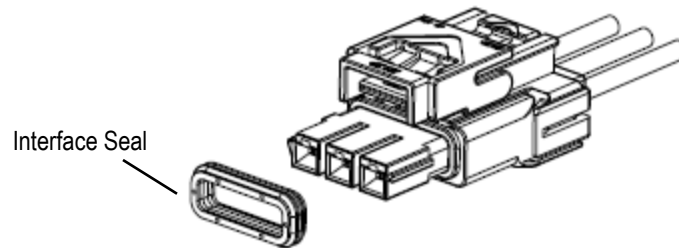

Figure 8

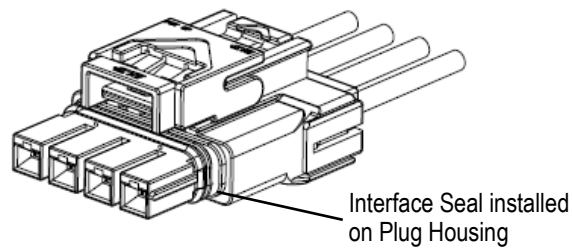

Figure 9

#### 3.2. Gang Seal Assembly

1. Select appropriate contacts, then follow termination procedures shown in Application Specification 114-143082.
2. Insert the gang seal into the contact cavities at the back end (wire side) of the cap and plug housings as shown in Figure 10.

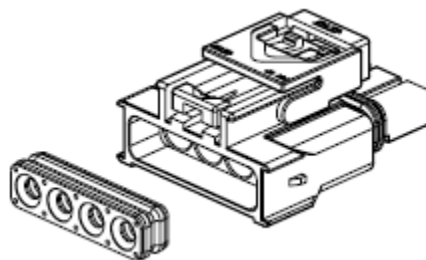

Figure 10

3. Align the terminated tab or receptacle contact with the appropriate cavity at the back end (wire side) of the plug or cap housing. This alignment is to help ensure that the gang seal will not be damaged during the insertion process. See Figure 11.

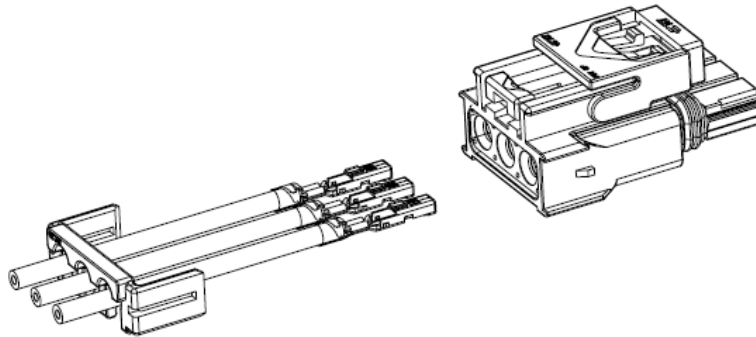

Figure 11

4. Grasp the wire directly behind the insulation barrel and push the contact straight into the housing cavity until contact locks in place. See Figure 12.



**CAUTION**

*Care must be taken to avoid nicks, tears, or other damage to gang seal when inserting contact.*

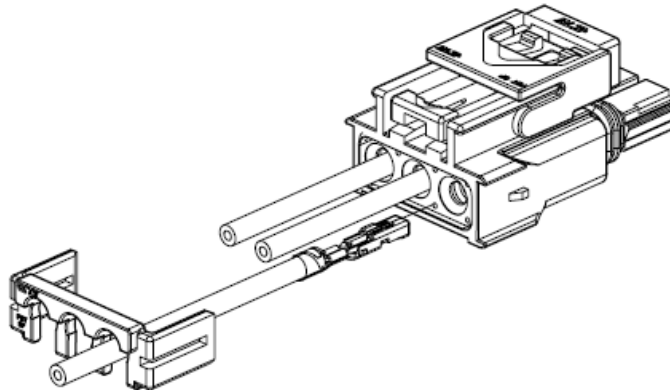

Figure 12

5. Assemble back cover to housing and ensure that locking latches for the back cover are engaged.

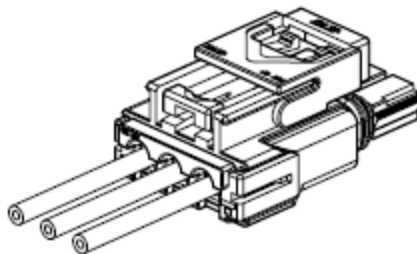

Figure 13

### 3.3. Sealing Plug Assembly

1. Assemble interface seal as indicated in Section 3.1.
2. Assemble gang seal with selectively loaded contacts as indicated in Section 3.2.
3. Align sealing plug with the appropriate cavity at the back end (wire side) of the plug or cap housing. See Figure 14.

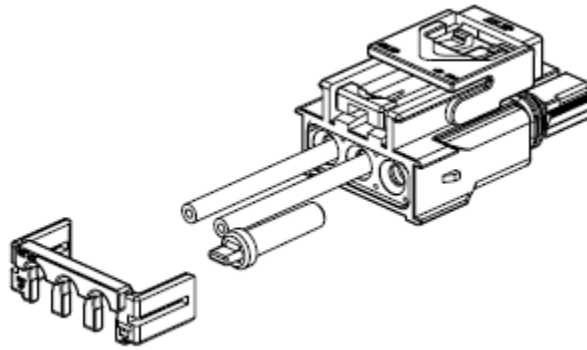

Figure 14

4. Push the sealing plug into the housing cavity until the sealing plug is flush with the gang seal. See Figure 15.

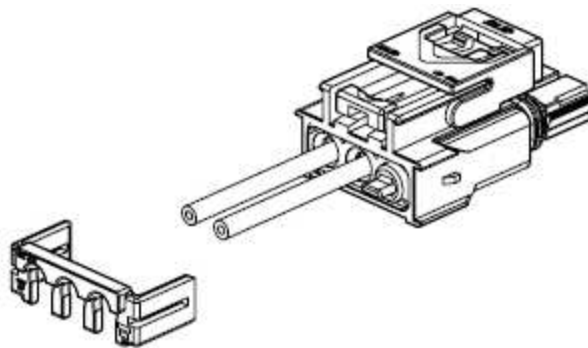

Figure 15

5. Assemble back cover to housing and ensure that locking latches for the back cover are engaged. See Figure 16.

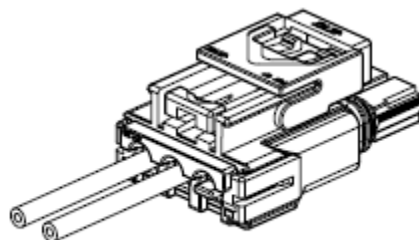

Figure 16