

30P Plug Connector, 2301461-[]



30P Cap Connector, 2301462-[]

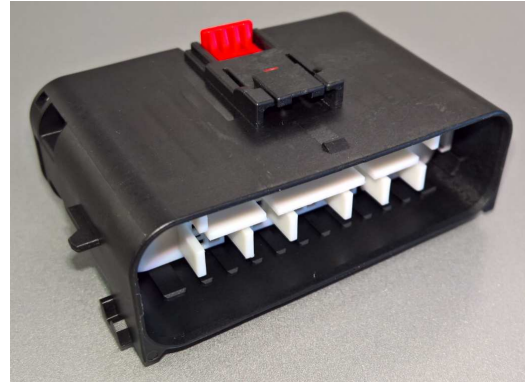

Figure 1

1. INTRODUCTION

This instruction sheet provides assembly, disassembly, mating, and un-mating procedures for the sealed harness connectors shown in Figure 1. The connectors are designed to use 1.2 MCON, 2.8 MCP, and 6.3 MCP terminal systems. Connector assemblies can be configured with specific patterns of blocked circuits, or in “all open” configuration and blocking of unused circuits accomplished by using “sealing plug” components. The CPA feature (Connector Position Assurance) for the lever mechanical assist is contained in the body of the Male Connector Outer Housing, so a separate Wire Dress Cover is not required but is optional.



NOTE

Terminal, seal, and sealing plug part numbers, as well as applicable Application Specifications are listed on connector customer drawings.



CAUTION

Sealing plugs are intended to be used only for prototyping purposes. Approval must be obtained from the end customer before using on a production intent harness.

2. DESCRIPTION

Each female connector assembly consists of an inner housing with circuit cavities, outer housing, lever mechanical assist, terminal secondary lock (ISL), peripheral seal, grommet (mat seal), and seal cover. A Wire Dress component to tie or route the wires exiting the rear of the connector is optional.

Each male connector assembly consists of an inner housing with circuit cavities, outer housing, pin protector plate, terminal secondary lock (ISL), grommet (mat seal), seal cover, and CPA. A Wire Dress component to tie or route the wires exiting the rear of the connector is optional.

The peripheral seal prevents moisture from entering the connector interface. The grommet seal prevents moisture from entering the connector body around the wires. The female connector outer housing contains latch features on each side that retain the lever in the pre-stage position for shipping and handling, and keep the lever in that position until properly mated to the male connector where the latches release the lever and allow it to “pop” a number of degrees of rotation signifying it is ready to be mated fully.

Once the lever is fully rotated completing the mating sequence, it will latch into the thumb latch of the cap outer housing. The CPA component is released at this point and able to be seated. The CPA is used to provide a visual indication that the connector is fully mated to the male connector, and provide reinforcement to the latch so that it is unable to be inadvertently released during high shock or vibration loads, water spray, or during vehicle maintenance procedures on surrounding areas.

Wire dress covers may be installed on one or both connectors. Wire dress covers are common to both connectors, and are reversible (able to be installed in either right or left exit).

3. ASSEMBLY PROCEDURE

3.1. Terminal Insertion

1. Crimp the terminals according to the Application Specifications listed on connector customer drawing, and ensure that the terminals are properly crimped.
2. Confirm ISLs are positioned in the open position as shown in Figure 2. When viewed in this orientation, with latch/lever up, the ISL should be slid fully to the left. This can be verified by looking at the exposed towers on the ends of the ISL and comparing them to the connector housings, using Figure 2 as a reference. If they are not, refer to Step 1 of Paragraph 4.3.

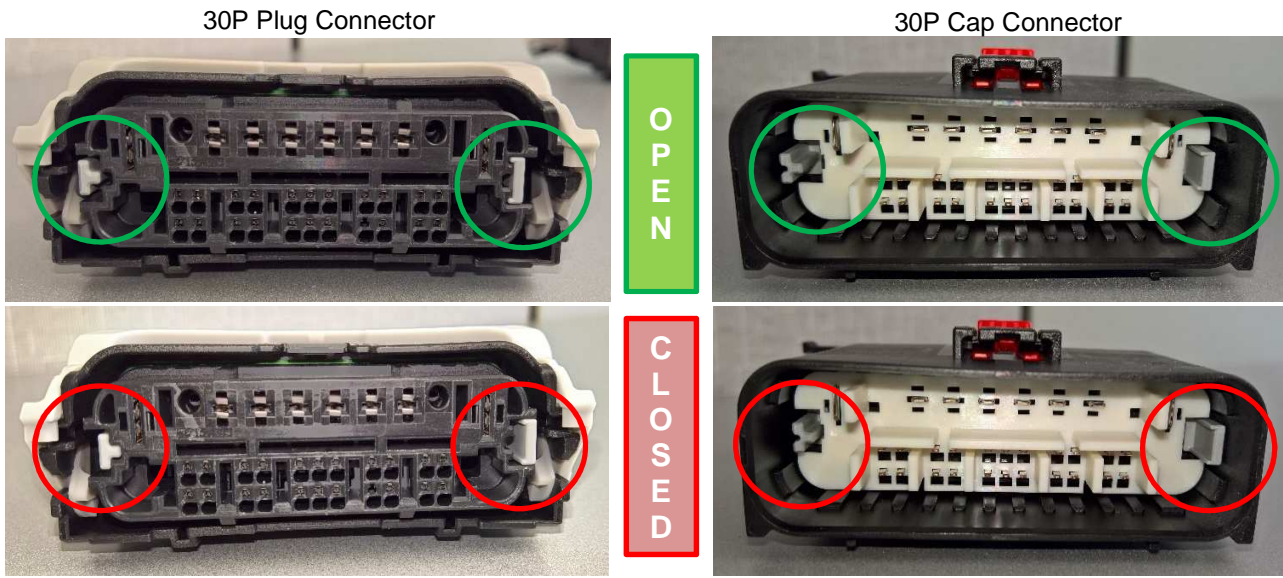

Figure 2

3. Align a crimped terminal with the appropriate circuit cavity of the connector so that the terminal is orientated as shown in Figure 3. The male connector is shown, but terminal orientation is the same for both male and female connectors. 1.2 circuits should have the orientation feature facing down, 2.8 terminals are oriented with the long side of the terminal box horizontal, and 6.3 terminals are oriented with the long side of the terminal box vertical.

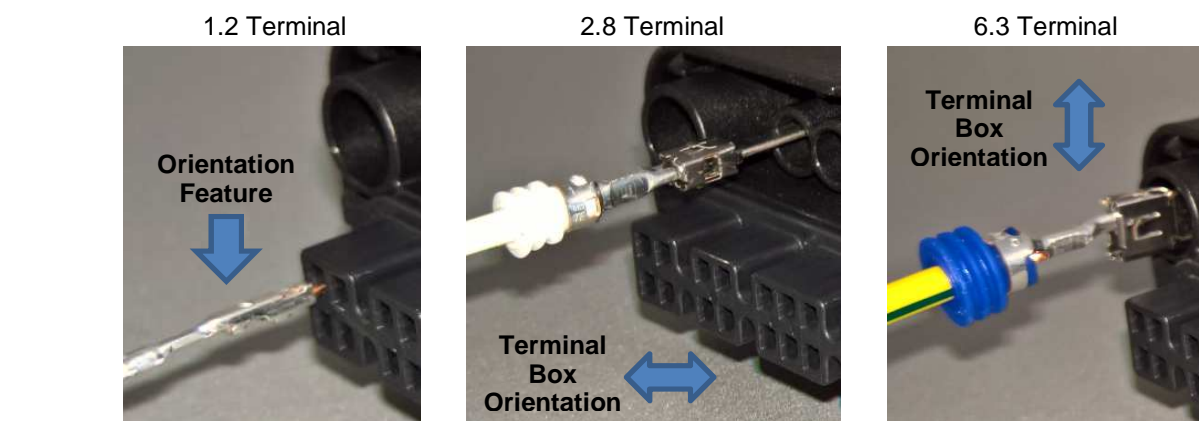

Figure 3

- Grasp the wire of the crimped terminal, and insert the terminal straight into the circuit cavity until it is fully inserted. If there is significant resistance during insertion, remove the terminal and verify proper orientation and ISL position. An audible and tactile click should be felt when terminals are fully latched into the circuit.



NOTE

If the terminal is difficult to insert into the circuit cavity, check for a de-populated arrangement. Refer to the wiring diagram on the customer drawing for the specific connector assembly.

- Lightly pull the wire to ensure that the terminal is latched.
- Follow step 3 through step 5 for the remaining terminals.
- After all terminals have been inserted, insert a small screwdriver or other suitable device as shown in Figure 4, to engage ISLs to the closed position by sliding to the right. Tool should be inserted as far down the tower of the ISL as possible. This can be verified by looking at the exposed towers on the ends of the ISL and comparing them to the connector housings, using Figure 5 as a reference.

30P Plug Connector

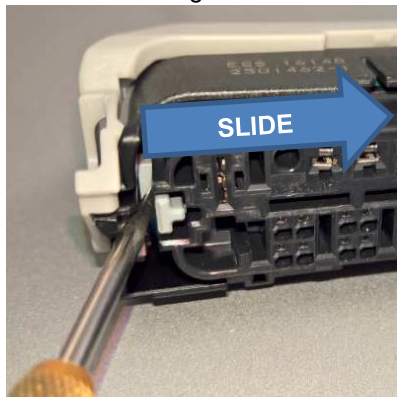

30P Cap Connector

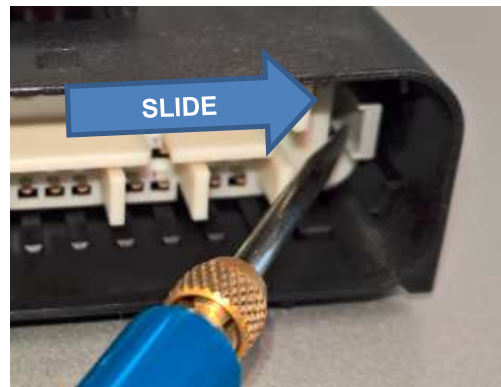

Figure 4

30P Plug Connector



C
L
O
S
E
D

30P Cap Connector

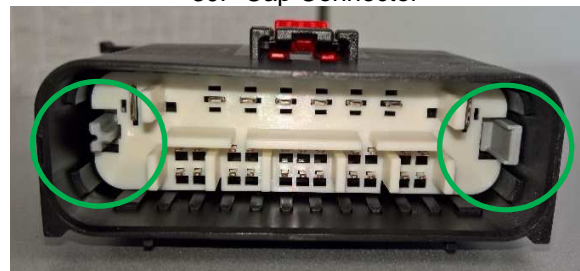

O
P
E
N

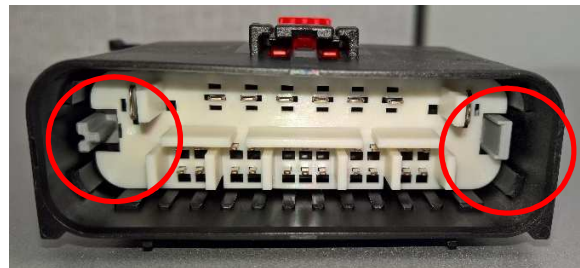

Figure 5



NOTE

If the ISL does not move easily into the closed position, one or more of the terminals is not fully inserted. Move the ISL to the open position (as described in Step 1 of Paragraph 4.3), then check that all terminals are fully inserted.

3.2. Wire Dress Assembly Installation (Optional)

**NOTE**

The wire dress cover should be installed after all terminals have been fully inserted.

1. Bundle the wires and bend them in a shape that will fit into the wire exit of the cover.
2. Align and insert the locking tabs of the wire dress cover into the windows of the connector outer housing. See Figure 6.

Locking Tabs
(2 Places)



Figure 6

3. Ensure that the wire bundle is completely captured within the wire exit of the wire dress cover and no wires are pinched between the connector housing and the wire dress cover, then rotate the wire dress cover toward the housing until the latch clicks into place. There will be an audible click. Figure 7 shows the wire dress cover fully seated onto the connector.



Figure 7

4. Using tape or wire ties, attach the wire bundle to the wire dress cover.

3.3. Connector Mating

1. If lever is not in the position shown in Figure 1, rotate it toward the wire exit end of the connector until it stops.
2. Align connectors as shown in Figure 8, and push connector halves together.

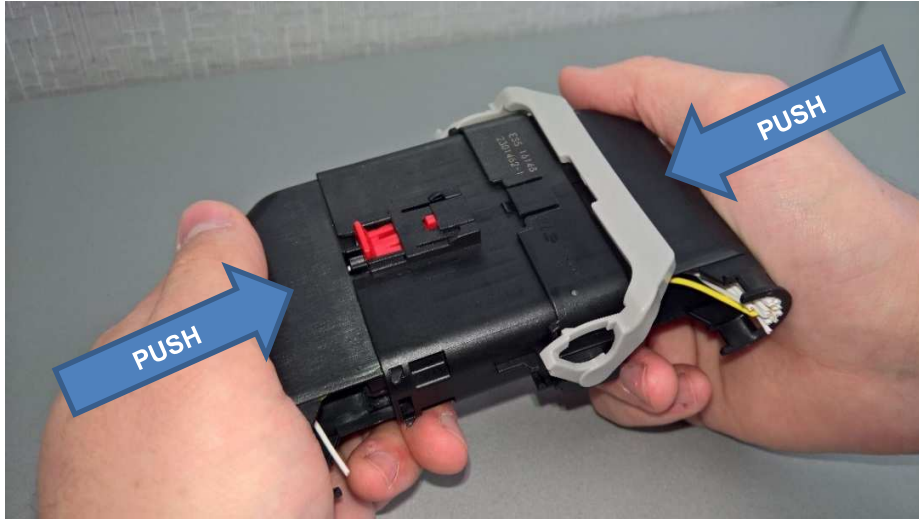

Figure 8



NOTE

If significant resistance is encountered, one or more ISLS may not be correctly located. Ensure that the ISLS are in the closed position (as described in Step 7 of Paragraph 3.1).

3. When pre-stage latch is over the ramp on cap connector (Figure 9), lever is able to be rotated. A small movement (or pop) of the lever may accompany this stage.

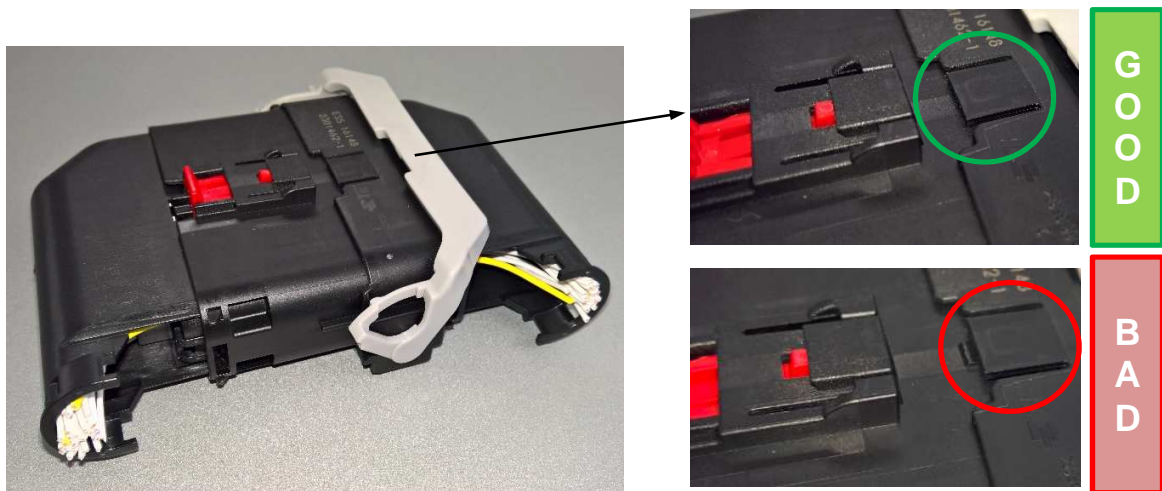

Figure 9

4. Alternatively, connector halves can continue to be pushed together manually until the lever pops further as shown in Figure 10.

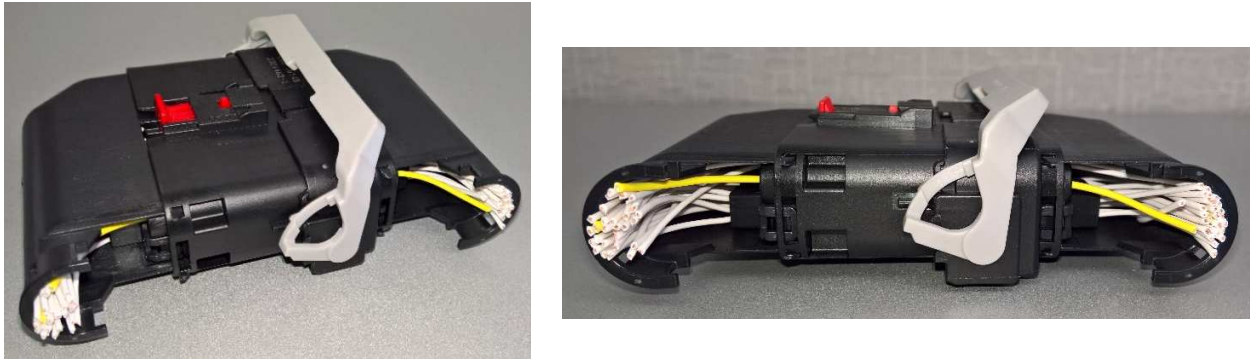

Figure 10

5. The lever can now be rotated toward the cap connector (See Figure 11), until it latches to the cap connector.

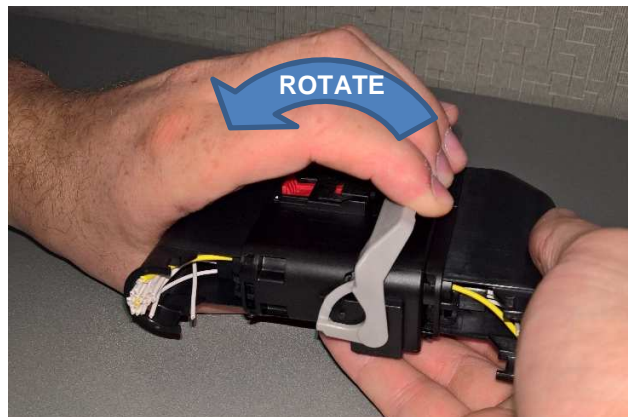

Figure 11

6. An audible and tactile click will accompany a lever that is properly latched to the cap, as shown in Figure 12.



Figure 12

7. The CPA can be engaged by sliding it toward the plug connector. See Figure 13.



NOTE

If there is significant resistance when sliding the CPA, ensure that the mating lever is completely latched in the closed position as shown in Figure 12.

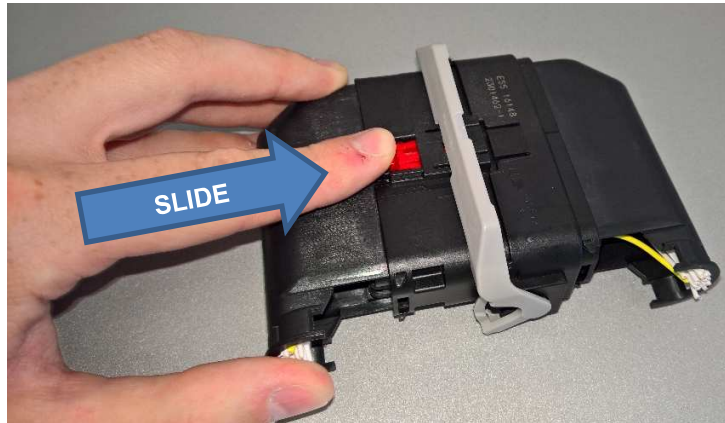

Figure 13

8. The connector system is now fully mated. See Figure 14.

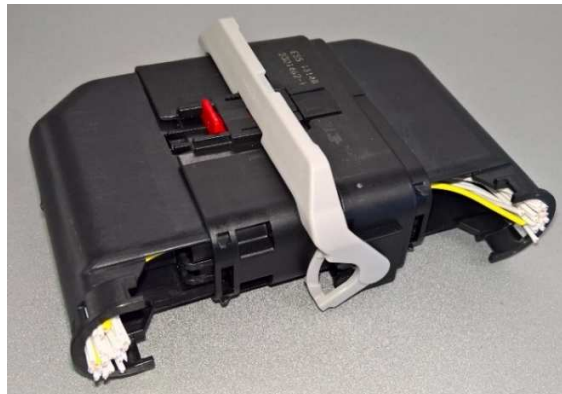

Figure 14

4. DISASSEMBLY PROCEDURES

Disassembly must be performed in the following order.

4.1. Connector Un-Mating

1. Disengage CPA by sliding it away from the plug connector. See Figure 15.



Figure 15

2. Depress connector latch as shown in Figure 16 until lever is free to rotate.

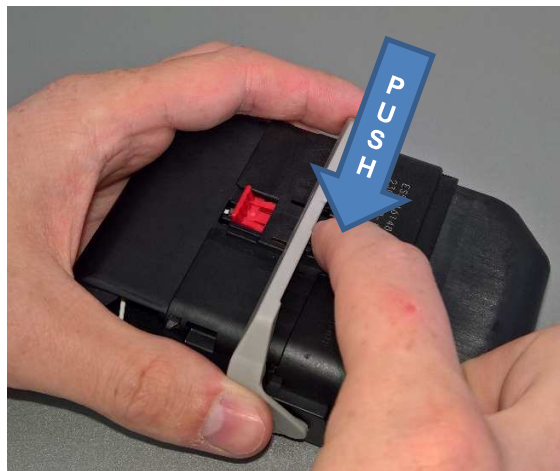

Figure 16

3. Rotate the lever away from the cap connector as shown in Figure 17 until the lever is flat against the plug connector/wire dress as shown in Figure 18.

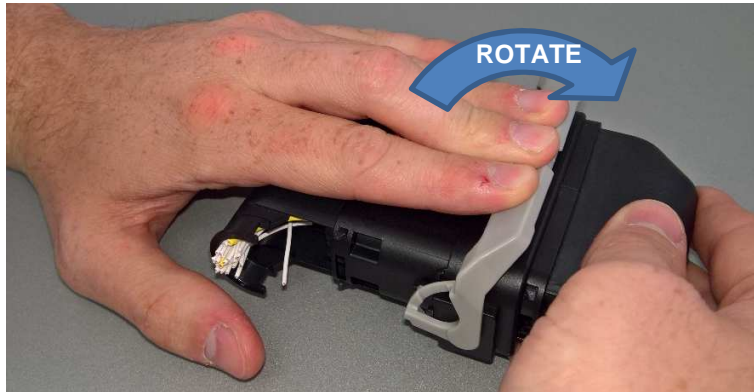

Figure 17



Figure 18

4. Pull connector halves apart as shown in Figure 19.

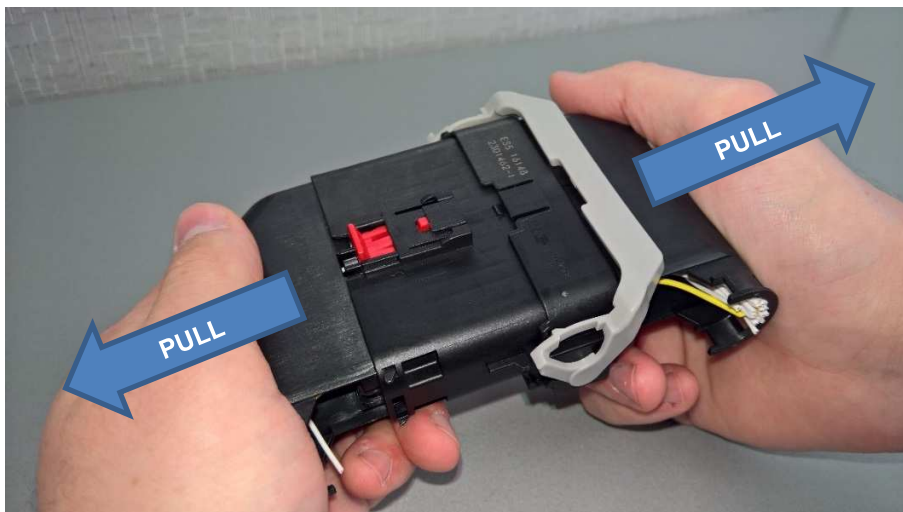

Figure 19

4.2. Wire Dress Assembly Removal

1. Using the tip of a screwdriver inserted into latch window of outer housing, release the latch of the wire dress cover by pushing inward on latch. See Figure 20.

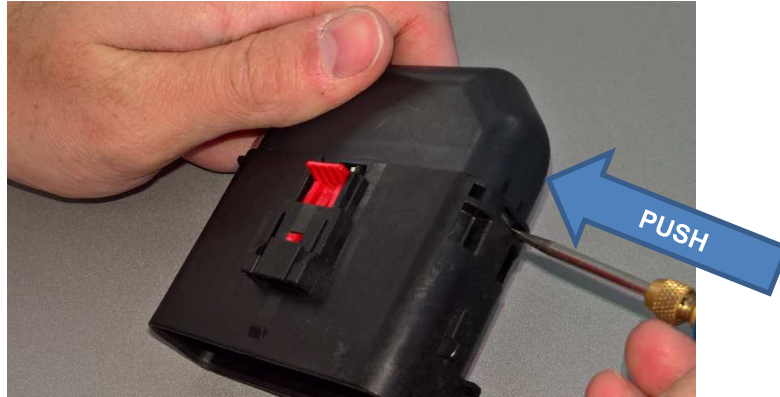

Figure 20

2. When latch is released, wire dress cover can be rotated upward and away from locking tab windows to free the wire dress from the connector assembly.

4.3. Terminal Removal

1. Terminals can be removed only when the ISL is in the open position. Insert a small screwdriver or other suitable device as shown in Figure 20, to disengage ISLs by sliding to the right. Tool should be inserted as far down the tower of the ISL as possible. This can be verified by looking at the exposed towers on the ends of the ISL and comparing them to the connector housings, using Figure 21 as a reference.

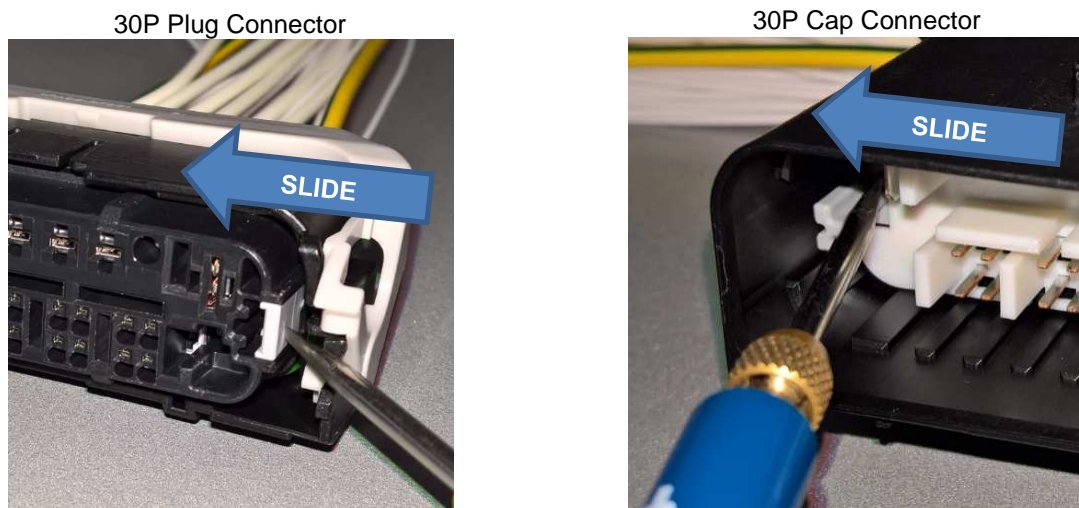

Figure 20

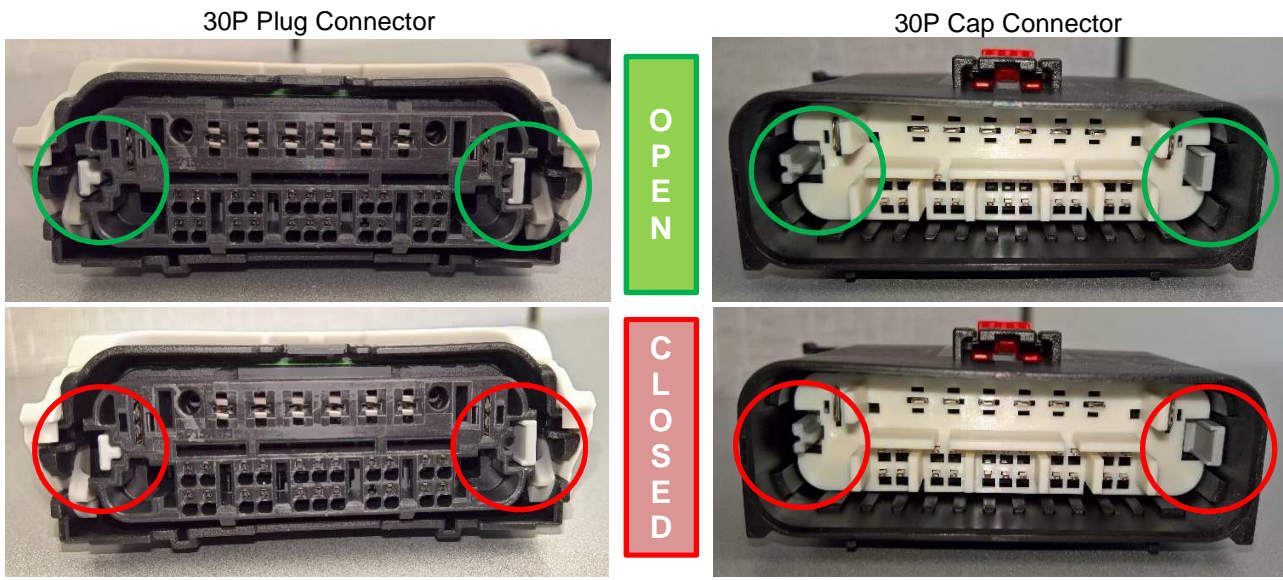

Figure 21

2. Push the wire of the terminal to be removed toward the circuit cavity so that the terminal moves toward the front of the housing.
3. Remove each terminal as follows (Female shown, male terminal removal is similar):
 - a. MCON 1.2: From the mating face of the connector assembly, insert the tip of removal tool into the opening below the circuit cavity of the terminal to be removed. Gently rotate the tool towards the terminal body, lifting the latch finger.

Suggested removal tools:

8-1579008-4 (TE Connectivity); or J-38125-215A (Kent Moore).

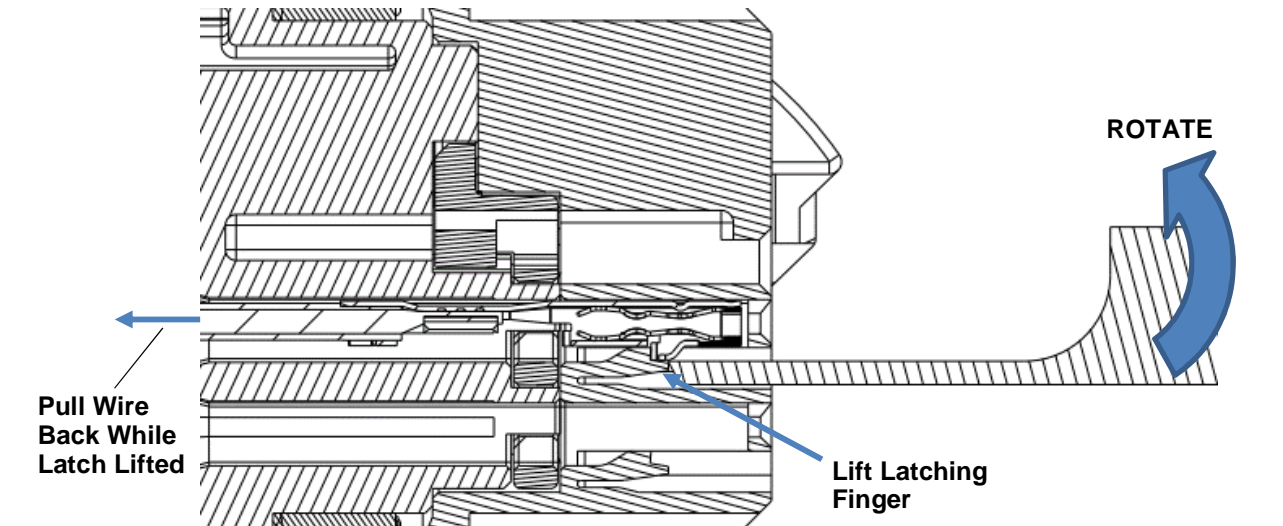

Figure 22

- b. MCP 2.8 and 6.3: From the mating face of the connector assembly, insert the tool straight into the openings on either side of the circuit cavity until locks are depressed and forward movement of the tool stops.

Suggested removal tools:

MCP 2.8: Female: 1-1579007-2 (TE Connectivity); or J-38125-557 (Kent Moore)

Male: 1-1579007-6 (TE Connectivity); or J-38125-36 (Kent Moore)

MCP 6.3: Female: 1-1579007-3 (TE Connectivity); or J-38125-557 (Kent Moore)

Male: 1-1579007-6 (TE Connectivity); or J-38125-36 (Kent Moore)

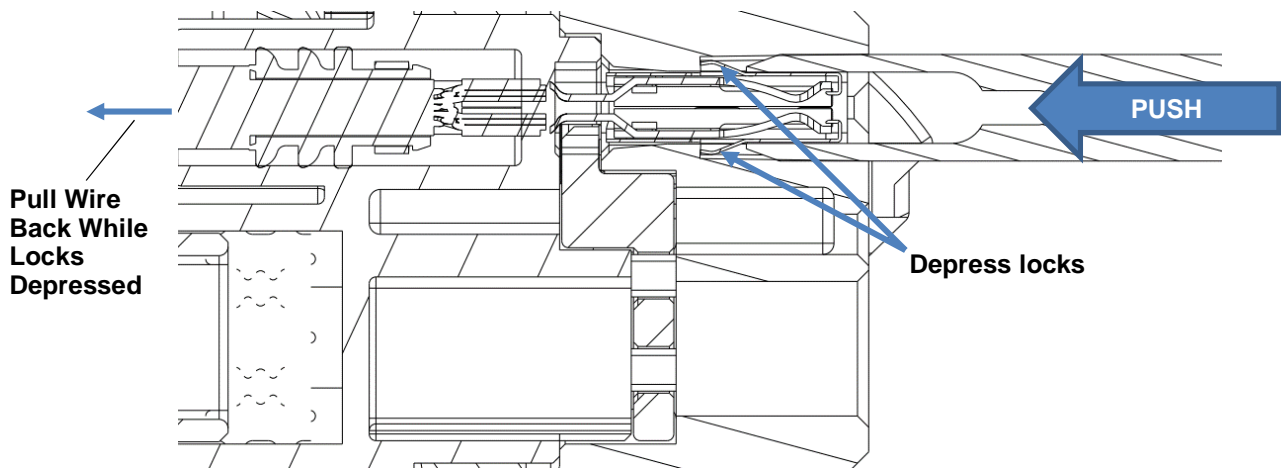

Figure 23

4. From the wire end of the connector assembly, gently pull the wire of the terminal to be removed until the terminal is out of the housing.



NOTE

If the terminal is not removing easily, verify that the ISL is in the open position as shown in Figure 21, and terminal is pushed forward in the cavity as described in Step 2.

5. ELECTRICAL PROBING

See Figures 24 and 25 for the designated areas to electrically probe connector assemblies.

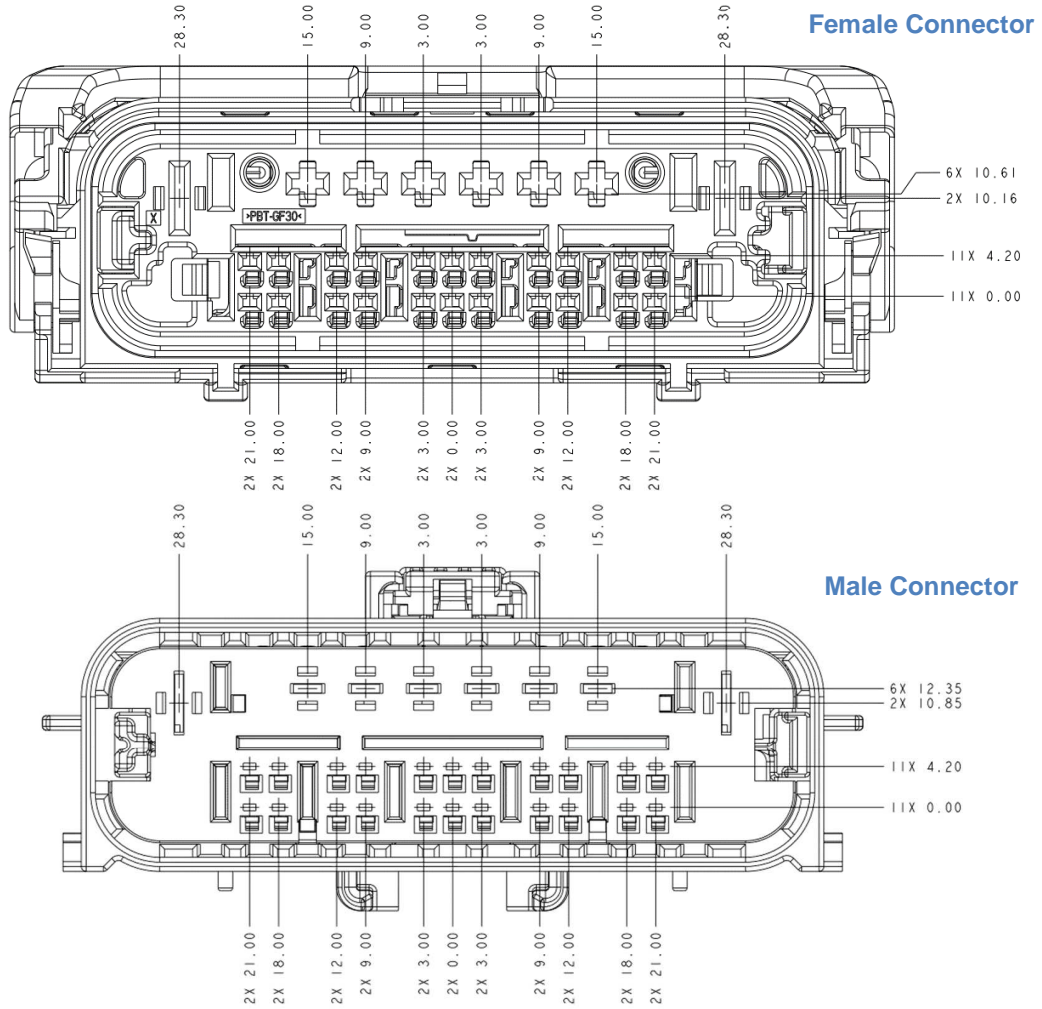
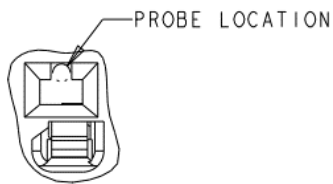
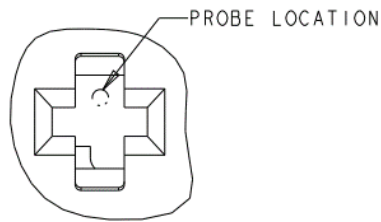

Figure 24 (Probe Spacing)

MCON 1.2 Female



MCP 2.8 Female



MCP 6.3 Female

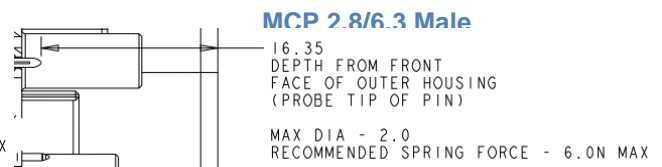
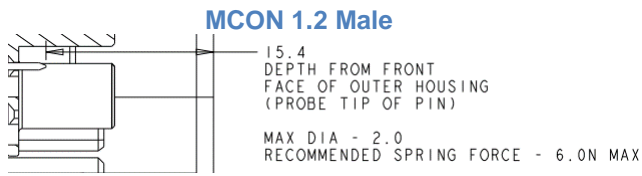
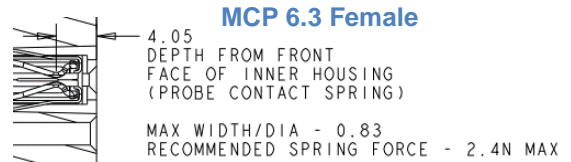
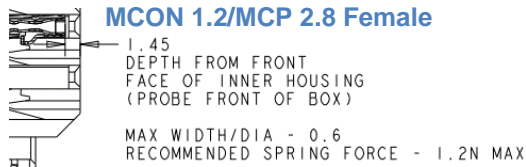
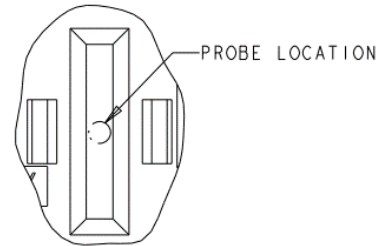

Figure 25 (Probe Details)

6. REPLACE AND REPAIR



CAUTION

These contacts and connectors are non-repairable. Damaged or defective contacts or connectors **MUST NOT** be used. A contact **MUST NOT** be re-terminated. The Wire Dress Cover, if equipped, can be replaced if damaged.

7. REVISION SUMMARY

- Initial release of document