

PLUG PART NUMBER		
TE PART NUMBERS		MILITARY NUMBER M39012/79-
TE NUMBER	PREVIOUS NUMBER	
1050793-1	2001-8207-92	3207
1050800-1	2001-8307-92	3307 (No Safety Wire Holes)

NOTE: Adherence to steps will yield tolerances shown on M39012/79

Figure 1

1. INTRODUCTION

SMA Straight Cable Plugs (Compression Crimp Attachment) 1050793-1 and 1050800-1 are designed to be crimped onto RG 405/U 2.16 [.085] diameter semi-rigid coaxial cable using the following tools shown in Figure 2.

TOOL DESCRIPTION	PART NUMBER CROSS-REFERENCE	
	TE PART NUMBER	PREVIOUS PART NUMBER
Crimp Tool Kit	---	2098-5657-54
Cable Pointer Tool	1080269-1	2098-5685-54
Cable Trim Tool	1055530-1	2098-5686-54
Cable Clamp Jaws	1055519-1	2098-5649-54
Anvil	---	2098-5652-02
Compression Crimp Installation Manual Kit	---	2098-5650-54
Compression Crimp Installation Pneumatic Kit	---	2098-5660-54
Pneumatic Kit Anvil	1055295-1	2098-0671-02

Figure 2

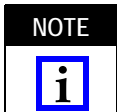

NOTE Dimensions on this instruction sheet are in millimeters [with inches in brackets]. Figures are not drawn to scale.

Reasons for reissue of this document are provided in Section 5, REVISION SUMMARY.

2. DESCRIPTION

The plug connector consists of a coupling nut, housing assembly, and bushing. See Figure 1.

3. ASSEMBLY PROCEDURE



Follow safety precautions included with the tools used for assembly.

1. Strip the cable to the dimensions shown in Figure 3.

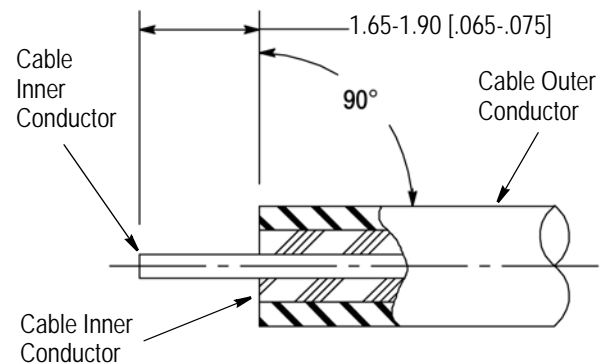

Figure 3

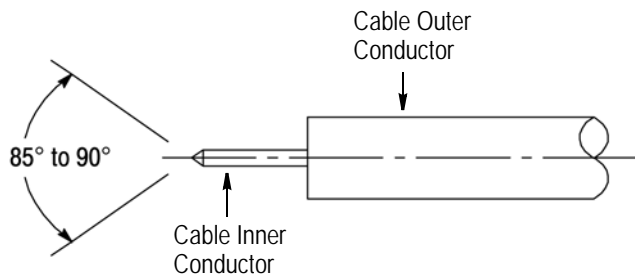

Figure 4

2. Shape the blunt end of the inner conductor to an 85° to 90° cone as shown in Figure 4.
3. To install the cable into the connector assembly, place the cable as shown in Figure 5.
4. Place the cable between the cable clamping jaws of the crimp tool.

5. Insert the cable inner conductor into the anvil and bottom the cable outer conductor flush with the face of the anvil as shown.



The connector assembly must remain clear of the cable clamping jaws.

6. Squeeze the handle of the crimp tool until the ratchet releases.

7. The assembly is now complete.



Damaged components must not be used. If a damaged component is evident, it must be removed and replaced.

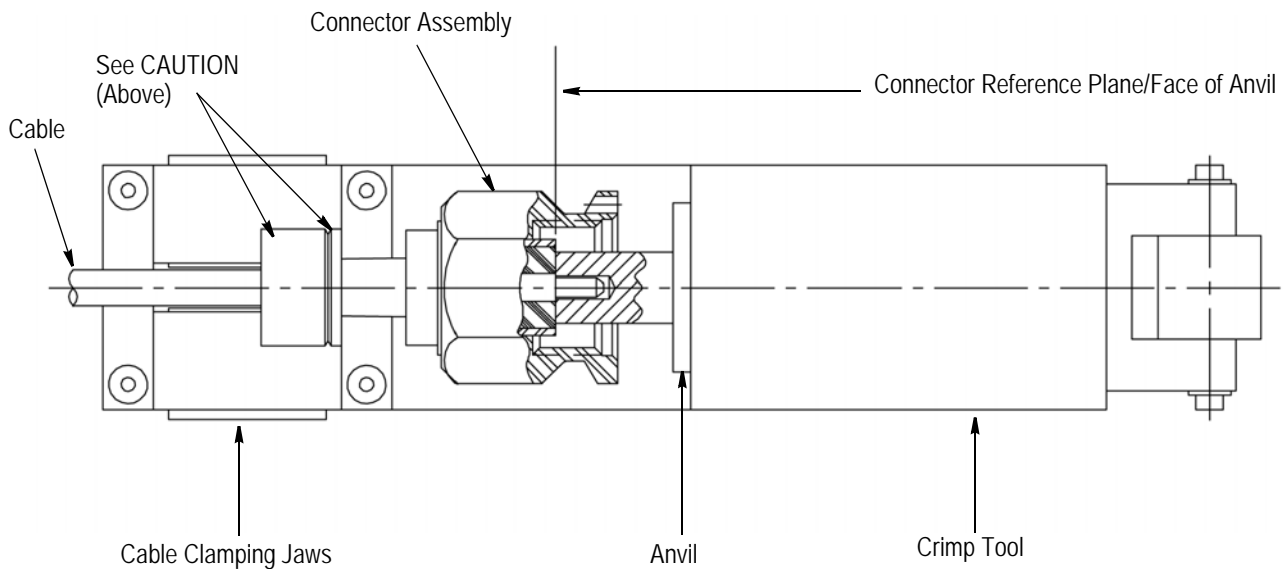

Figure 5

4. MILITARY INFORMATION

MILITARY MAINTENANCE TOOLS	
Crimp Tool:	M22520/36-01
Positioning Dies:	M22520/36-02
Locator Tool:	M22520/36-18

5. REVISION SUMMARY

Since the previous release of this document, the TE Connectivity logo has been applied