

CONNECTOR TYPE	CABLE TYPE	TOOLS REQ'D
OSM STRAIGHT CABLE PLUG, RETRACTABLE COUPLING NUT, DIRECT SOLDER ATTACHMENT	.141 DIA SEMI-RIGID CABLE	FIXTURE BASE: 2098-5206-54 (T-4567) CLAMP INSERT: 2098-5207-54 (T-4700-1) CENTER CONTACT HOLDER: 2098-5221-10 (T-4578) SOLDER GAGE: 2098-5516-02 (T-4562-5) LOCATOR TOOL: 2098-5218-02 (T-2367)

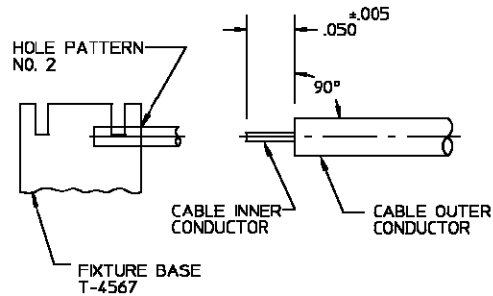

### ASSEMBLY OPERATIONS

- 1.0 PREPARATION OF CABLE.
- 1.1 INSERT SQUARED CABLE END INTO FIXTURE BASE HOLE PATTERN #2.
  - 1.2 PLACE SAW IN SAW SLOT AND CUT THROUGH OUTER CONDUCTOR AND INTO DIELECTRIC WHILE ROTATING CABLE.
  - 1.3 REMOVE CABLE FROM FIXTURE AND FINISH CUTTING DIELECTRIC WITH CUTTING BLADE.



- 2.0 SOLDERING OF CENTER CONTACT TO CABLE INNER CONDUCTOR.
- 2.1 TIN INNER CONDUCTOR OF CABLE.
- 2.2 PLACE SOLDER GAGE ON INNER CONDUCTOR, FLUSH WITH END OF OUTER CONDUCTOR.
- 2.3 PLACE CENTER CONTACT IN HOLDER, HEAT CENTER CONTACT AND PUSH IT OVER INNER CONDUCTOR OF CABLE TO REST FIRMLY AGAINST SOLDER GAGE.
- 2.4 REMOVE SOLDER GAGE AND EXCESS SOLDER.

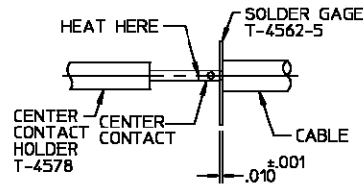

- 3.0 SOLDERING OF CABLE TO HOUSING
- 3.1 SCREW HOUSING ASSEMBLY ONTO LOCATOR TOOL.
- 3.2 CAREFULLY INSERT CABLE ASSEMBLY INTO PRE-ASSEMBLED DIELECTRIC OF HOUSING ASSEMBLY.
- 3.3 PLACE LOOSE ASSEMBLY IN FIXTURE BASE AS SHOWN.
- 3.3.1 BOTTOM LOCATOR TOOL AGAINST FIXTURE BASE AS SHOWN.
- 3.3.2 MAINTAINING PRESSURE ON CABLE TO KEEP LOCATOR TOOL BOTTOMED, TIGHTEN CLAMP SCREW TO SECURE CABLE.
- 3.4 SOLDER CABLE TO HOUSING.

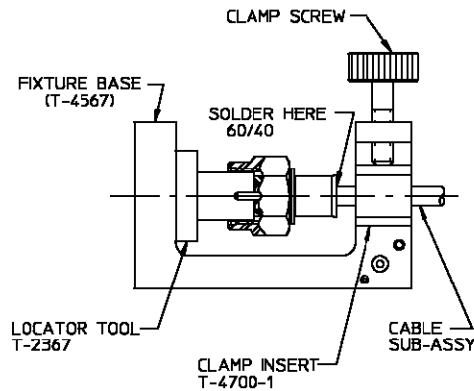

NOTE: FIXTURE SHOULD BE CLAMPED VERTICALLY IN VISE (SO THAT CONNECTOR INTERFACE IS FACING DOWN).

- 4.0 INSPECTION OF COMPLETED CONNECTOR ASSEMBLY.
- 4.1 ADHERENCE TO STEPS GIVEN WILL YIELD TOLERANCES SHOWN.

