

CONNECTOR TYPE

OSM HERMETIC JACK
 FLANGE MOUNT FIELD REPLACEABLE
 SOLDER ON GLASS SEAL

TOOLS REQUIRED:

HERMETIC SEAL SOLDERING FIXTURE: 2098-5615-54
 HARDWARE NOT SUPPLIED BY MANUFACTURER:
 FOUR (4) MACHINE SCREWS: #2-56, UNC-2A X .125 LONG
 SOLDER PREFORM (TYPE OPTIONAL) .015-.020 RECOMMENDED DIA.

CONNECTOR

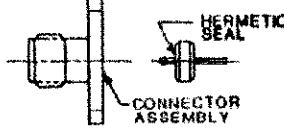

ASSEMBLY OPERATIONS

1.0 MOUNTING HOLE PREPARATION

- 1.1 DRILL PILOT HOLE THRU PANEL DIAMETER PER CUSTOMER APPLICATION.
- 1.2 INSERT STEP REAMER INTO PILOT HOLE AND REAM .102 ±.001 DIA HOLE TO DEPTH AS SHOWN.
- 1.3 DRILL AND TAP #2-56UNC-2B THREAD 4 PLACES AS SHOWN.
- 1.4 PLATE PER CUSTOMER APPLICATION
- 1.5 CLEAN IN SOLVENT

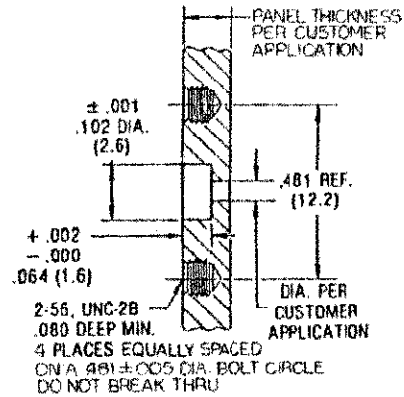

2.0 INSTALLATION OF HERMETIC SEAL ASSEMBLY

- 2.1 CLEAN HERMETIC SEAL IN SOLVENT (DO NOT HANDLE HERMETIC SEALS AFTER CLEANING)
- 2.2 ASSEMBLE FLANGE ASSEMBLY, OF HERMETIC SEAL SOLDERING FIXTURE, ONTO PANEL AS SHOWN.
- 2.3 ASSEMBLE APPROPRIATE SOLDER PREFORM INTO MOUNTING HOLE.
- 2.4 THINLY COAT O.D. OF HERMETIC SEAL WITH FLUX (DO NOT FLUX CONTACT EXTENSION).
- 2.5 USING TWEEZERS, ASSEMBLE HERMETIC SEAL ASSEMBLY INTO MOUNTING HOLE AS SHOWN.
- 2.6 THREAD HERMETIC SEAL SOLDERING FIXTURE INTO FLANGE ASSEMBLY AND BOTTOM.
- 2.7 APPLY SUFFICIENT HEAT TO FLOW SOLDER.
- 2.8 DISASSEMBLE FLANGE ASSEMBLY AND HERMETIC SEAL SOLDERING FIXTURE.

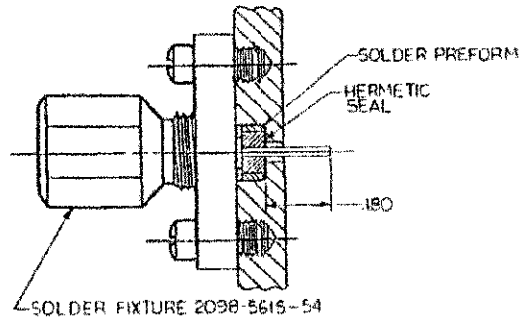

3.0 INSTALLATION OF CONNECTOR ONTO PANEL

- 3.1 INSTALL CONNECTOR ONTO PANEL AS SHOWN, BEING SURE THAT HERMETIC SEAL PIN ENTERS CENTER CONTACT OF CONNECTOR.
- 3.2 ASSEMBLY IS NOW COMPLETE.

