

INSERTION TOOL		WIRE	
Part No.	Shank Color	Size (AWG)	Qty Per Terminal
552714-1	Yellow	22-18	2
552714-2	Red	24-18	1
552714-3	White	28-24	2
552714-4	Blue	28-22	2
552714-5	Green	28-26	2

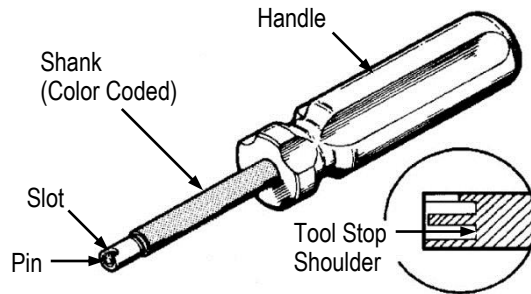

Figure 1

This insertion tool is designed to insert 1 or 2 unstripped wires into an AMP-BARREL terminal installed onto a printed circuit (pc) board. Features of the insertion tool are shown in Figure 1.

i **NOTE**
For terminal installation, refer to instruction sheet 408-6505.

1. USING THE TOOL

i **NOTE**
If any small dents, burrs, or chips are evident on the sleeve of the tool, remove them using a fine abrasive.

1. Place the wire over the terminal slot so that the end of the wire is flush with the inside back of the terminal.
2. Position the pin end of the tool so that the wire enters the tool slot. See Figure 2.
3. Press the tool straight down until the tool stop bottoms on the terminal. Remove the tool.
4. For 2-wire insertion, repeat steps 1 through 3 (second wire will push first wire below C-shaped cross slot). See Figure 2.

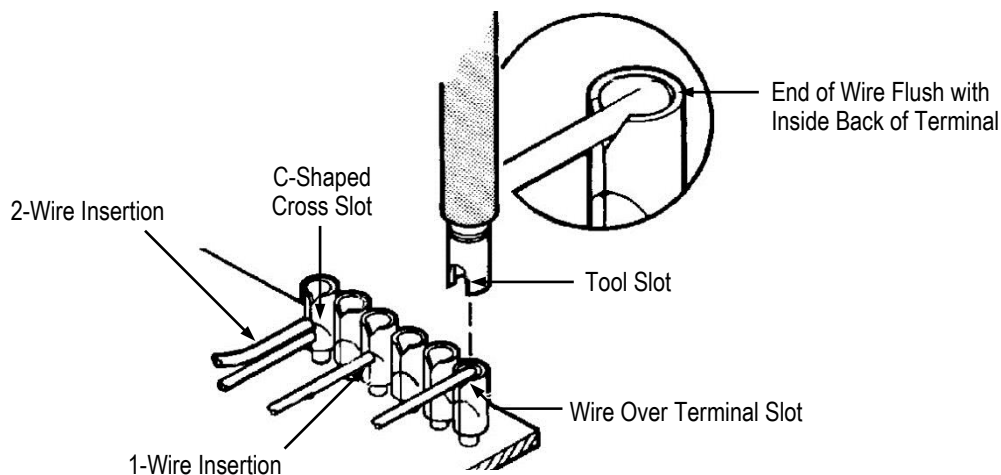

Figure 2

2. REVISION SUMMARY

Revisions to this instruction sheet include:

- Removed terminal part numbers and previous Sections 2 and 4