



AMP INCORPORATED  
HARRISBURG, PENNA.

A-MP\* TYPE I CONTACT  
CRIMPING DIE-SET FOR USE IN  
A-MP AIR GUNS NO. 69365

<b>IS 72 25</b>	
RELEASED	5-3-65
REVISED	9-24-65

CONNECTOR PRODUCTS DIVISION

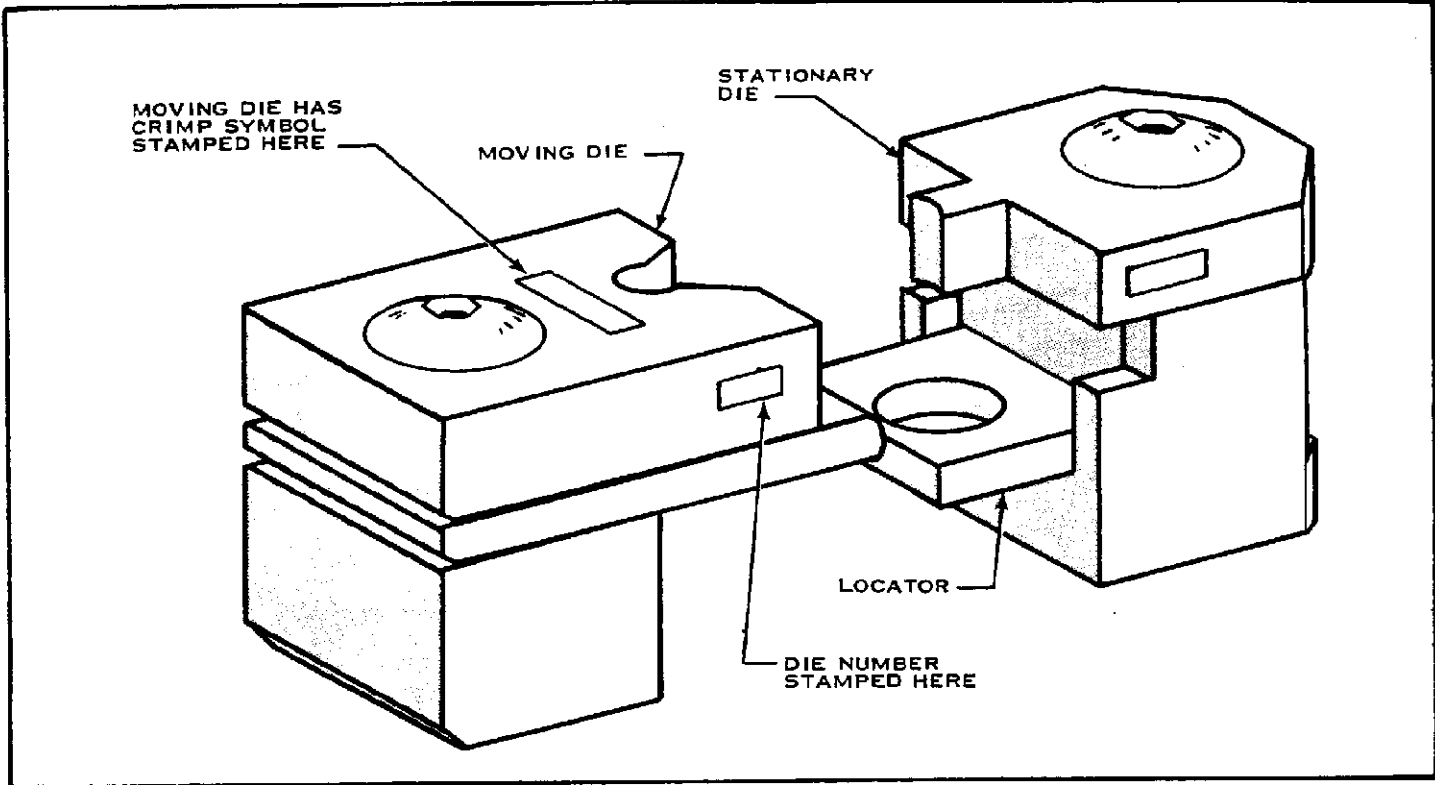
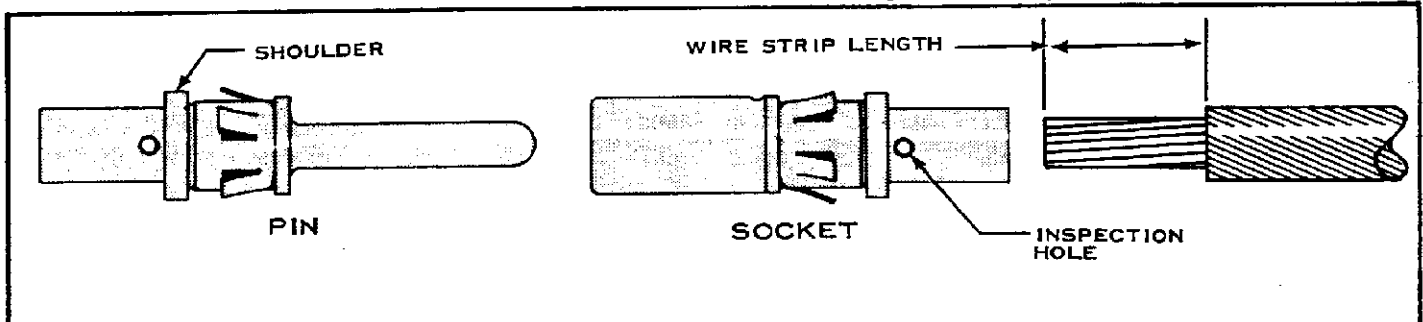

FIG. 1

1. This Die-Set (see Figure 1) is used to crimp the A-MP Type I Pin and Socket Contacts whose part numbers are listed in Figure 2. Read these instructions and those packaged with the Air Gun before using the Die-Set.

2. CONTACT SELECTION

- (a) Refer to Figure 2 to obtain the part number of the Pin and Socket Contacts which will accommodate the size of wire you wish to crimp.
- (b) Make sure the Crimp Symbol shown in Figure 2 for the Contacts you have chosen matches the Crimp Symbol stamped on the Moving Die. See Figure 1.



WIRE SIZE	CONTACT NUMBER		DIE NUMBER	CRIMP SYMBOL	WIRE STRIP LENGTH
	SOCKET	PIN			
18-16	202418-□	202421-□	90122-□	18-12	17/64"
14-12	202417-□	202422-□			

FIG. 2

\*Trademark of AMP Incorporated

© 1965 by AMP Incorporated. All international rights reserved. A-MP® products covered by U. S. and foreign patents and/or patents pending.

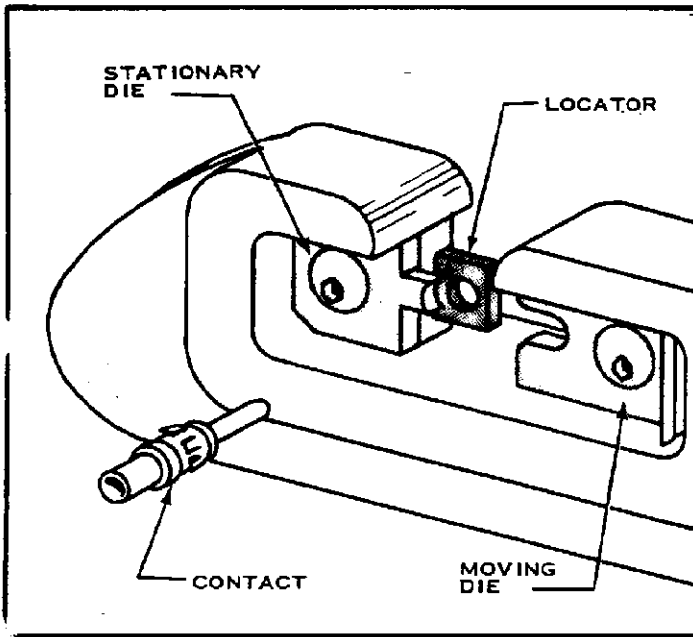

FIG. 3

### 3. WIRE STRIPPING

Strip Insulation from end of Wire as shown in Figure 2.

### 4. DIE-SET INSERTION

The instructions packaged with the Air Gun will explain insertion and removal of the Die-Set.

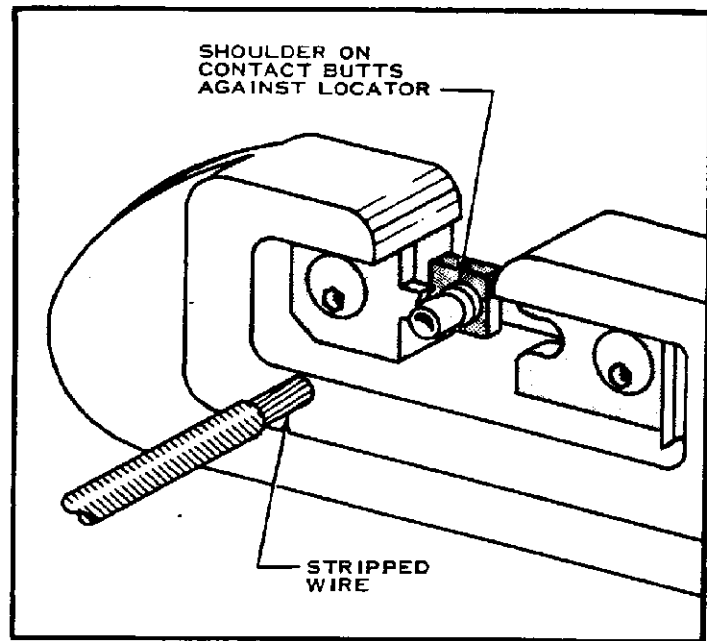

FIG. 4

### 5. CRIMPING PROCEDURE

- (a) Place Contact in Locator as shown in Figure 3. Make sure Shoulder on Contact butts against Locator. See Figure 4.
- (b) Complete crimping operation using the instructions packaged with the Air Gun.