

**PROPER USE GUIDELINES**

Cumulative Trauma Disorders can result from the prolonged use of manually powered hand tools. AMP hand tools are intended for occasional use and low volume applications. AMP offers a wide selection of powered application equipment for extended-use, production operations.

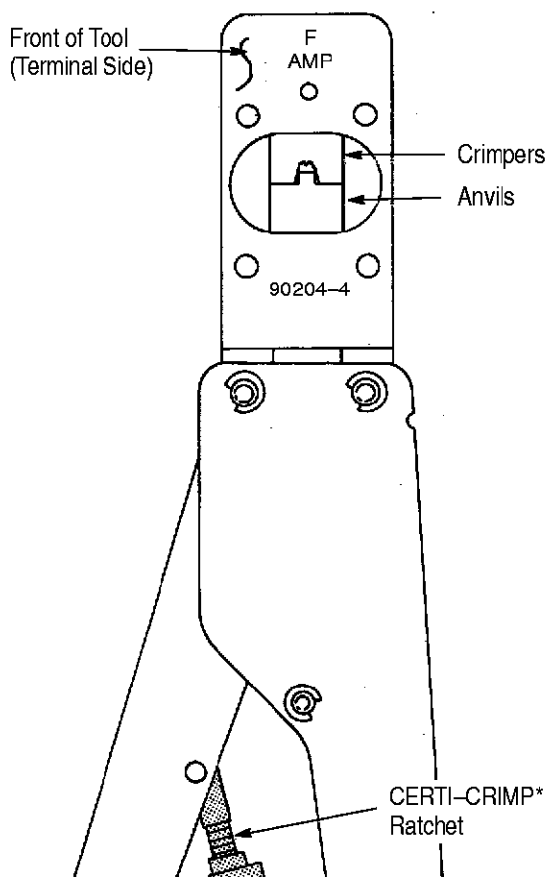

Figure 1

**1. INTRODUCTION**

AMP\* Hand Crimping Tool 90204-4 is designed to crimp the loose piece (LP) AMP Pin Receptacles listed in Figure 2. Read these instructions before using the tool.

**NOTE** Dimensions are in millimeters [with inch equivalents in brackets]. Figures are for identification only and are not drawn to scale.

Reasons for reissue are provided in Section 6, REVISION SUMMARY.

**2. DESCRIPTION** (Figure 1 and Figure 3)

The tool number is marked on the front of tool (terminal side). This is the side into which the contact is inserted. The wire size is marked above the crimp section on the back of the tool (wire side). This is the side of the tool into which the wire is inserted.

This tool contains two fixed dies (crimpers), two movable dies (anvils), a locator/insulation stop, and a CERTI-CRIMP ratchet.

The locator/insulation stop positions the terminal between the crimping dies. In addition, the locator/insulation stop aids in locating the wire in the terminal. In use, it is positioned in the terminal locator slot. See Figure 3.

The CERTI-CRIMP ratchet assures that a full crimp is applied to the contact. Once engaged, the ratchet will not release until the tool handles have been fully closed.

**CAUTION** The crimping dies bottom before the CERTI-CRIMP ratchet releases. This is a design feature that assures maximum electrical and tensile performance of the crimp. Do NOT re-adjust the CERTI-CRIMP ratchet.

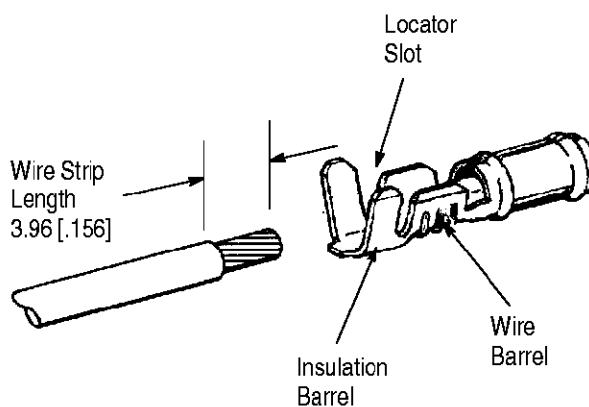

| WIRE       |                         | TERMINAL NUMBER |         | CRIMP SECT (Wire Size Marking) |
|------------|-------------------------|-----------------|---------|--------------------------------|
| SIZE (AWG) | INSUL DIA               | LP              | STRIP   |                                |
| 24 to 20   | 1.14 - 1.78 [.045-.070] | 60789-1         | 60598-1 | 24-20                          |

Figure 2

### 3. CRIMPING PROCEDURE

1. Refer to the table in Figure 2, select a wire of the specified size and strip the wire to the dimension provided. Do NOT nick or cut the wire strands.
2. Select a terminal using the table in Figure 2.
3. Hold the tool so that the back (wire side) of the tool is facing you. See Figure 3.
4. Make sure that the ratchet is released. Squeeze the tool handles together and allow them to open fully.
5. Looking straight into the back of the crimp section, insert the terminal (insulation barrel first) into the front of the crimp section.
6. Position the terminal in the crimpers so that the locator enters the terminal locator slot. See Figure 3.
7. Hold the terminal in this position and squeeze the tool handles together until the insulation anvil begins entry into the insulation crimper. Do NOT deform the insulation barrel or wire barrel.
8. Insert a properly-stripped wire into the wire slot in the locator and into the wire barrel of the terminal until the insulation butts against the locator/insulation stop. See Figure 3.

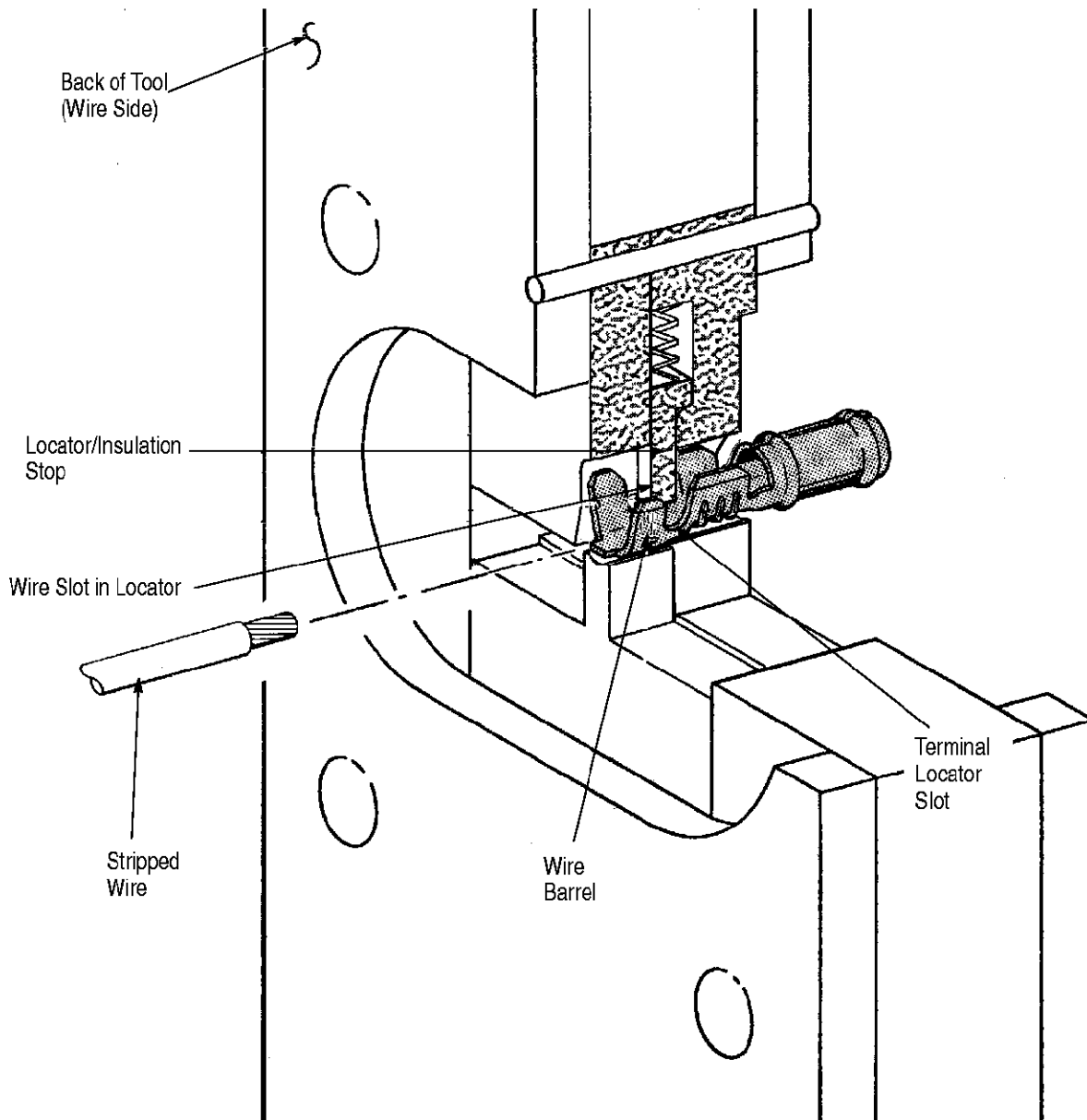

Figure 3

9. Hold the wire in place and squeeze the tool handles together until the ratchet releases.

10. Allow the tool handles to open fully and remove the crimped contact

**4. MAINTENANCE/INSPECTION**

**4.1. Daily Maintenance**

Remove all foreign particles with a clean, soft brush or a clean, soft, lint-free cloth. Make sure the proper retaining pins are in place and are secured with the proper retaining rings. If foreign matter cannot be removed easily, or if the proper replacement parts are not available, return the tool to your supervisor.

Make sure all pivot points and bearing surfaces are protected with a thin coat of any good SAE 20 motor oil. Do NOT oil excessively. When the tool is not in use, keep the handles closed to prevent objects from becoming lodged between the dies, and store the tool in a clean, dry area.

**4.2. Periodic Inspection**

Regular inspection should be performed by quality control personnel. A record of scheduled inspections should remain with the tool and/or be supplied to the supervisory personnel responsible for the tool. Though recommendations call for at least one inspection a month, the inspection frequency should be based on the amount of use, ambient working conditions, operator training and skill, and established company standards. These inspections should be performed in the following sequence:

**A. Visual Inspection**

1. Remove all lubrication and accumulated film by immersing the tool (handles partially closed) into a suitable degreaser that will not affect paint or plastic material.
2. Make certain all retaining pins are in place and are secured with the proper retaining rings. If replacement retaining rings are necessary, refer to Figure 5.
3. Close the tool handles until the ratchet releases, and then allow the handles to open freely. If they do not open quickly and fully, then the spring is defective and must be replaced (see Section 5, REPLACEMENT AND REPAIR).
4. Inspect the tool, with special emphasis on checking for worn, cracked, or broken crimping dies. If damage to any part of the head is evident, return the tool to AMP for evaluation and repair (see Section 5, REPLACEMENT AND REPAIR).

**B. Crimp Height Inspection**

This inspection requires the use of a micrometer, with modified anvil, as shown in Figure 4. AMP recommends the modified micrometer (Crimp Height Comparator RS-1019-5LP) available from:

Shearer Industrial Supply Co.                      VALCO  
 20 North Penn Street                              or                      1410 Stonewood Drive  
 York, PA 17401-1014                              Bethlehem, PA 18017-3527

To measure the crimp height:

1. Refer to Figure 4, select a contact and a wire (maximum size) for each crimp section listed in the table.
2. Crimp the contact(s) according to the procedures provided in Section 3, CRIMPING PROCEDURE.
3. Using the crimp height comparator, measure the wire barrel crimp height as shown in Figure 4. If the crimp height conforms to the dimensions provided in Figure 4, then the tool is considered dimensionally correct. If the crimp height does not conform to the dimensions provided, return the tool to AMP for evaluation and repair (refer to Section 5, REPLACEMENT AND REPAIR).

For additional information concerning the use of the crimp height comparator, refer to AMP Instruction Sheet 408-7424.

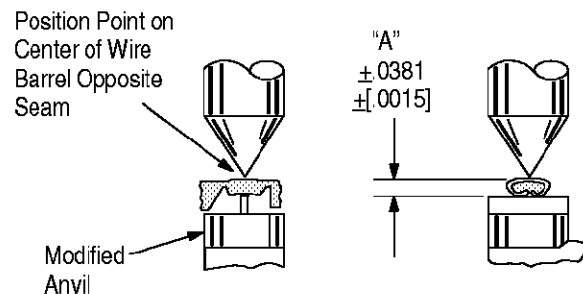

| TERMINAL NUMBER (LP) | WIRE SIZE AWG (Max) | CRIMP SECTION (Wire Size Marking) | CRIMP HEIGHT DIMENSION "A" |
|----------------------|---------------------|-----------------------------------|----------------------------|
| 60789-1              | 20                  | 24-20                             | .84 [.0330]                |

Figure 4

**C. CERTI-CRIMP Ratchet Inspection**

Obtain a 0.025-mm [.001-in.] shim that is suitable for checking the clearance between the bottoming surfaces of the crimping dies. To inspect the ratchet, proceed as follows:

1. Select a terminal, wire (maximum size), and locate the proper crimp section of the tool.
2. Position the terminal in the tool, as described in Section 3, CRIMPING PROCEDURE. While

holding the wire in place, squeeze the tool handles together until the ratchet releases. Hold the tool handles in this position, maintaining just enough pressure to keep the dies closed.

3. Check the clearance between the bottoming surfaces of the dies. If the clearance is 0.025 mm [.001 in.] or less, then the ratchet is satisfactory. If the clearance exceeds 0.025 mm [.001 in.], the ratchet is out of adjustment and must be repaired.

If the tool conforms to these inspection procedures, lubricate it with a THIN coat of any good SAE 20 motor oil and return it to service.

**5. REPLACEMENT AND REPAIR**

The parts listed in Figure 5 are customer-replaceable. A complete inventory can be stocked and controlled to prevent lost time when replacement of parts is necessary. Order replacement parts through your AMP representative, or call 1-800-526-5142, or send a facsimile of your purchase order to 1-717-986-7605, or write to:

CUSTOMER SERVICE (38-35)  
AMP INCORPORATED  
P.O. BOX 3608  
HARRISBURG, PA 17105-3608

Tools may be returned to AMP for evaluation and repair. For tool repair service, contact an AMP representative at 1-800-526-5136.

**6. REVISION SUMMARY**

The following changes were made since the previous release of this sheet:

Per EC 0990-0864-99

- Changed tool repair service information in Section 5, REPLACEMENT AND REPAIR
- Removed obsolete part numbers
- Revised the title
- Updated document format

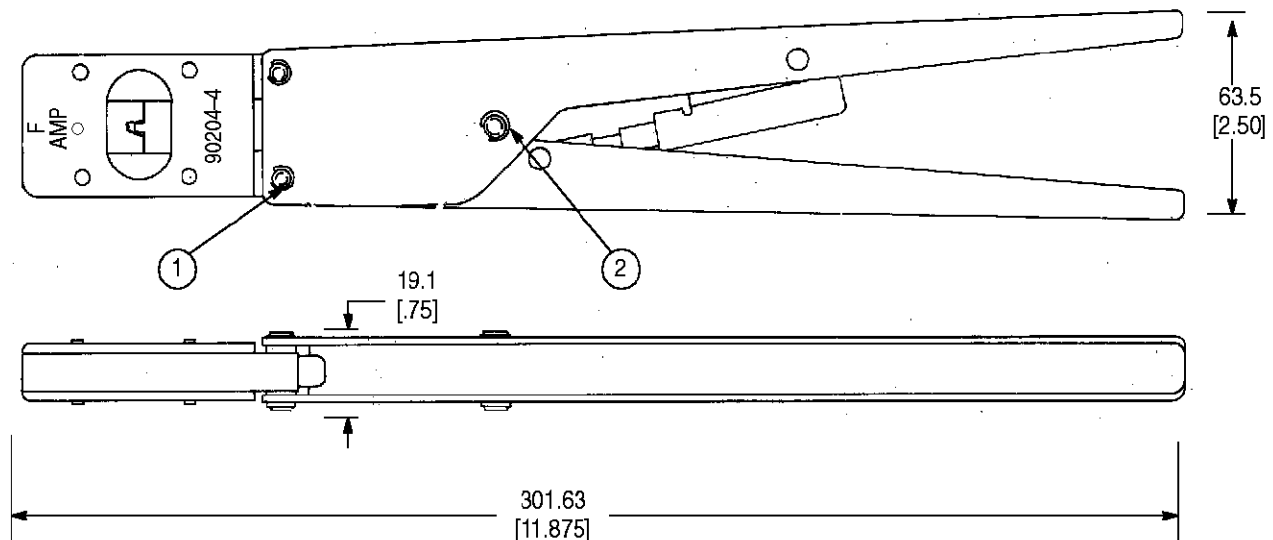

**WEIGHT:** 567 g [1 lb. 4 oz.]

**CAUTION** Do not remove the retaining pins or permanent damage to the tool may result.

| REPLACEMENT PARTS |             |                 |              |
|-------------------|-------------|-----------------|--------------|
| ITEM              | PART NUMBER | DESCRIPTION     | QTY PER ASSY |
| 1                 | 21045-3     | RING, Retaining | 4            |
| 2                 | 21045-9     | RING, Retaining | 2            |

Figure 5