

SPECIFICATION	RACK	
	1435045-1	1435046-1
Height	1829 mm [72.0 in.]	2134 mm [84.0 in.]
Width	483 mm [19.0 in.]	483 mm [19.0 in.]
Mounting Holes	117	132
Mounting Spaces (1U)	39	44

Figure 1

1. INTRODUCTION

Standard Equipment Racks 1435045-1 and 1435046-1 are used for mounting equipment that does not require an environmental enclosure. Specifications for the racks are listed in Figure 1.

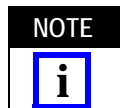

Dimensions in this instruction sheet are in millimeters [with inches in brackets]. Figures are not drawn to scale.

The rack is designed to be anchored to the floor using the following kits:

- Concrete Floor Installation Kit 559311-1
- Wood Floor Installation Kit 559311-2



The rack must be anchored to the floor to prevent it from tipping over when equipment is mounted

Read these instructions thoroughly before starting assembly or installation.

2. DESCRIPTION

The rack consists of top support angle plates, base support angle plates, support rails, assembly hardware, and equipment mounting hardware. See Figure 1.

The support rails contain mounting holes for the mounting the equipment. The arrangement of the mounting holes complies with the standard Electronic Industries Alliance (EIA) alternating hole pattern of 31.75 to 12.7 [1 ¼ to ½]. See Figure 2.

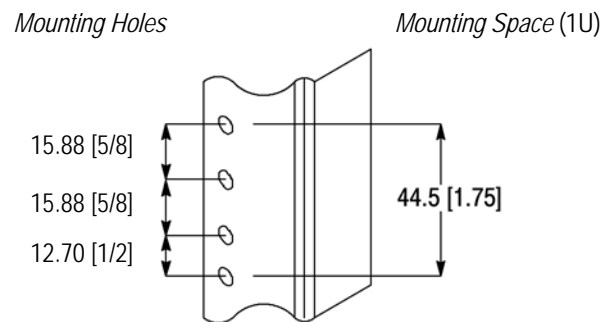

Figure 2

3. ASSEMBLY



ALWAYS use safe lifting techniques. NEVER lift more than you can manage comfortably. Lifting guidelines are available from the Occupational Safety and Health Administration (OSHA).

Unpack the rack components and hardware from the carton, and inventory all parts according to Figure 1. Then proceed as follows:

3.1. Tools Required

The following tools are required for assembly:

- ½-in. box end wrench
- carpenter's square

- measuring tape
- 3/4-in. wood drill bit (for wood floor installation) or 5/8-in. masonry drill bit (for concrete floor installation)

3.2. Assembling the Rack

Refer to Figure 1, and proceed as follows:

1. Lay both support rails flat on the floor with the flanges facing each other.
2. Lay one base support angle plate and one top support angle plate on the support rails, aligning the assembly holes. Using the wrench, attach the support angle plates to the support rail with four of the hex head bolts. Do NOT tighten the bolts at this time.
3. Turn the rack over, and attach the other base support angle plate and top support angle plate in the same manner. Do NOT tighten the bolts at this time.
4. Using the carpenter's square, align the rack between the support rails at both the top and bottom of the rack. Tighten all the bolts.
5. Stand the rack upright. Check that the support rails are square with the base support and top support angle plates. Tighten the bolts to a torque between 13.5 and 16.3 Nm [10 and 12 ft-lbs].



TORQUE FOR THESE BOLTS MUST BE NO MORE THAN THE MAXIMUM STATED.

3.3. Installing the Rack onto Concrete Floor

Refer to Figure 3, and proceed as follows:

1. Place the rack on the floor at a permanent location. Use the four installation holes in the base support angle plate as a template, and mark the center of the holes onto the floor.
2. Move the rack away from the marks on the floor. Using the masonry drill bit, drill a 64 [2.5] deep hole into the floor at each mark.
3. Screw a stud into an anchor until the stud protrudes approximately 13 [.5] beyond the bottom of the anchor. Slide a fender washer, split lockwasher, and hex nut onto the stud. Follow this procedure for the three remaining hardware assemblies.

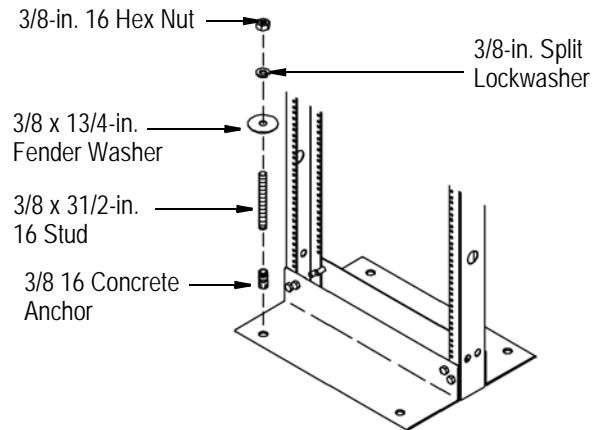

Concrete Floor Installation

Figure 3

4. Align the installation holes in the base support angle plate with the holes in the floor. Insert the hardware assemblies, anchor first, through the mounting holes in the rack and into the floor.
5. Tighten the hex nuts to a torque between 23 and 25.7 Nm [17 and 19 ft-lbs].

3.4. Installing the Rack onto Wood Floor

Refer to Figure 4, and proceed as follows:

1. Place the rack on the floor at a permanent location.

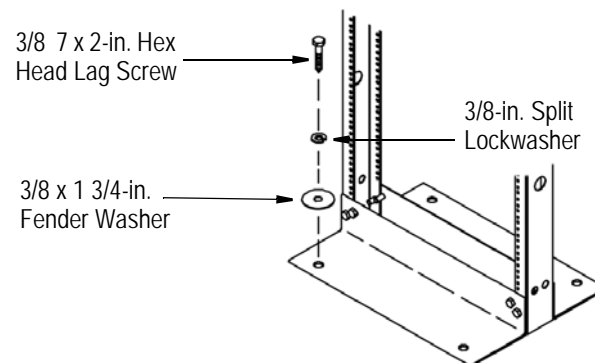

Wood Floor Installation

Figure 4

2. Using the wood drill bit, drill a 38 [1.5] deep hole into the floor at each mounting hole in the base support angle plate.

3. Slide a lockwasher and fender washer onto a hex head lag screw. Follow this procedure for the three remaining hardware assemblies.

4. Insert the hardware assemblies through the installation holes in the base support angle plate and into the floor. Tighten the hex head lag screws.

3.5. Mounting Equipment

Using the combination pan head and pilot point mounting screws, mount equipment onto the support rails of the rack. Tighten these screws to a torque of 3.39 Nm [30 in.-lb].

4. REPLACEMENT

The racks are not repairable if damaged. Order racks through your representative, or call 1-800-526-5142, or send a facsimile of your purchase order to 717-986-7605, or write to”

CUSTOMER SERVICE (038-035)
TYCO ELECTRONICS CORPORATION
PO BOX 3608
HARRISBURG PA 17105-3608

5. REVISION SUMMARY

Revisions to this instruction sheet include:

- Changed company name and logo