

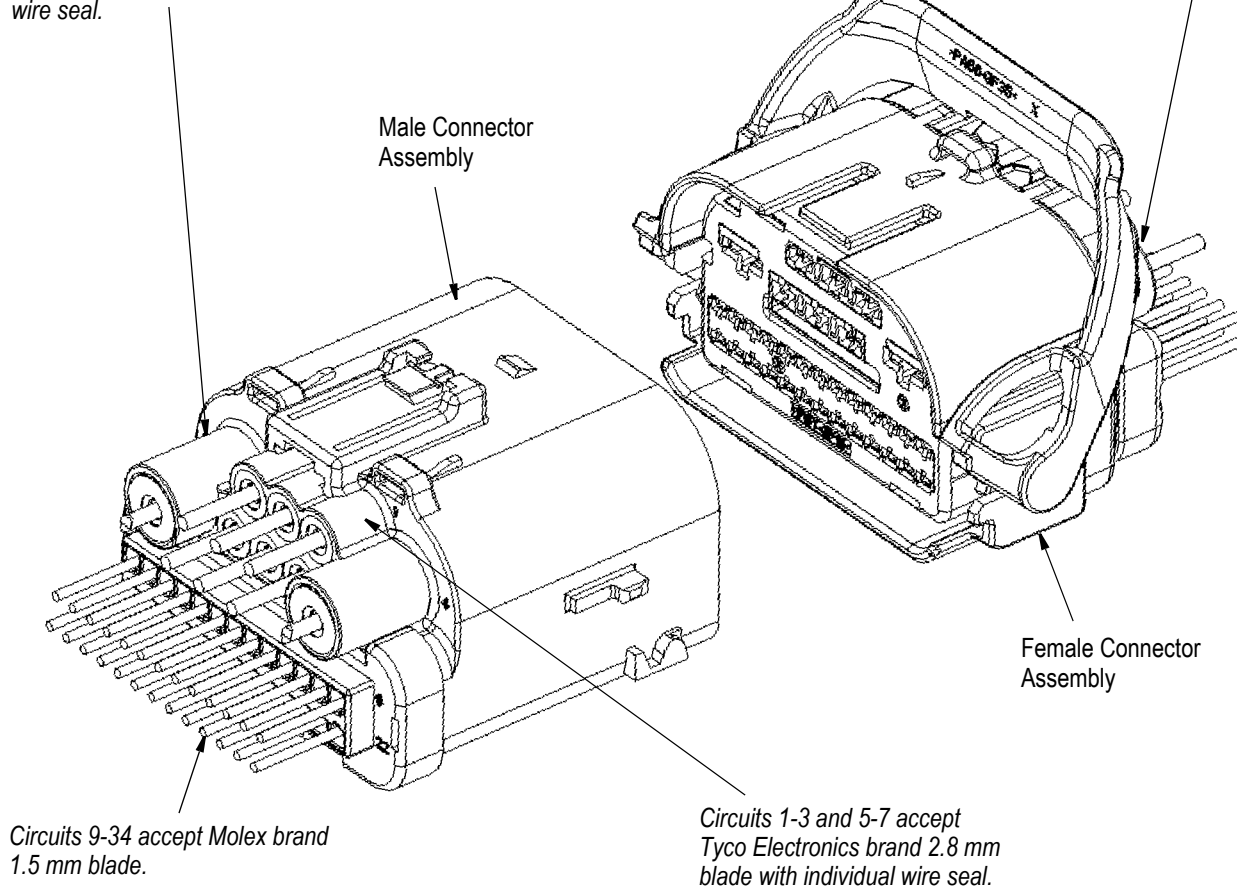

All numerical values are in metric units [with U.S. customary units in brackets]. Dimensions are in millimeters [and inches]. Unless otherwise specified, dimensions have a tolerance of ± 0.13 [$\pm .005$] and angles have a tolerance of $\pm 2^\circ$.

Circuits 4 & 8 accept Yazaki brand 6.3 mm blade with individual wire seal.

Circuits 1-3 and 5-7 accept Tyco Electronics brand 2.8 mm receptacle, with individual wire seal. Circuits 4 & 8 accept Yazaki brand 6.3 mm receptacle with individual wire seal. Circuits 9-34 accept Molex brand 1.5 mm receptacles.



Circuits 9-34 accept Molex brand 1.5 mm blade.

Circuits 1-3 and 5-7 accept Tyco Electronics brand 2.8 mm blade with individual wire seal.

1. INTRODUCTION

The 34-Position Hybrid Connector is an in-line wire-to-wire system used in both passenger compartment and under-hood applications. The connector system is sealed to protect against environmental exposures and utilizes three different terminal systems for various current-carrying capabilities.

The male and female connectors are shipped fully assembled and ready for terminal installation.

The following procedures describe the proper use of this connector system and the individual components and accessories used in the connector.

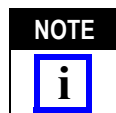

Figures and illustrations are for reference only, and are not drawn to scale.

Reasons for revision may be found in REVISION SUMMARY at the end of this document.

A. Female Contact Assembly Instructions (Cont'd)

1

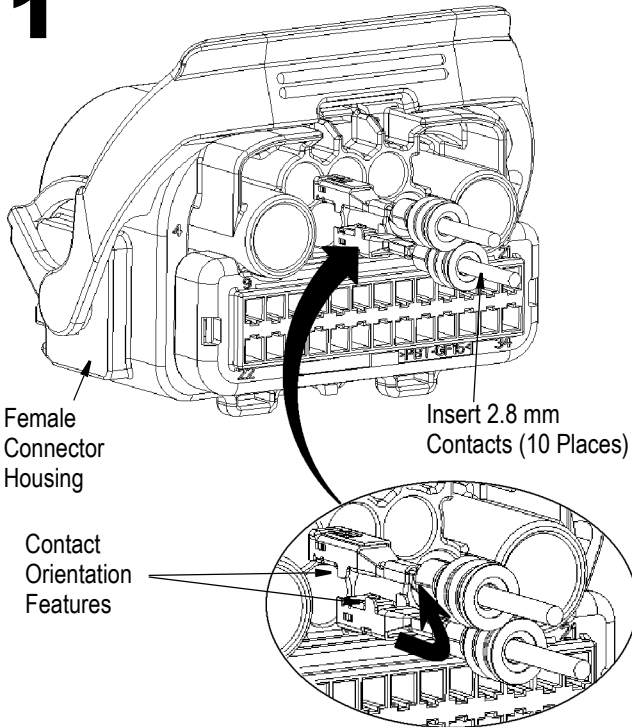

Lower contact row oriented 180° from upper contact row

2

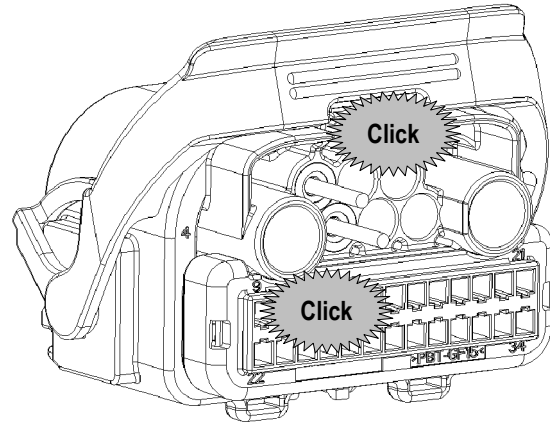

Insert contact until an audible "Click" is heard or felt. Pull slightly on wire to ensure full seating. If resistance is felt prior to full seating, refer to Section "C" to verify connector TPA is in the pre-lock position.

3

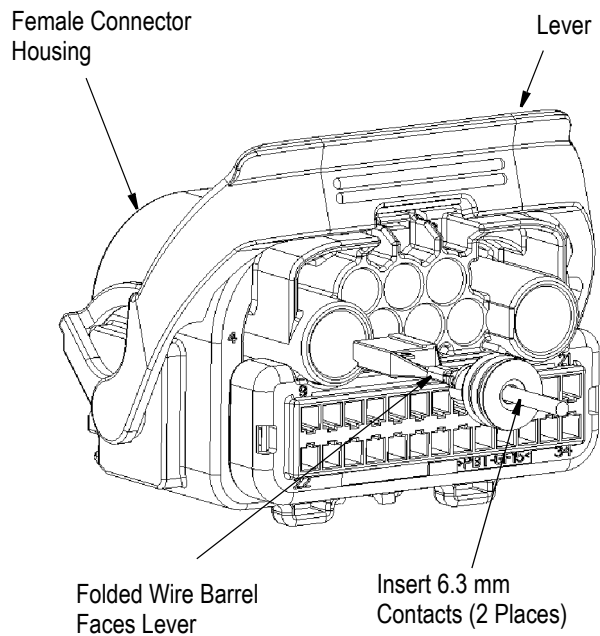

4

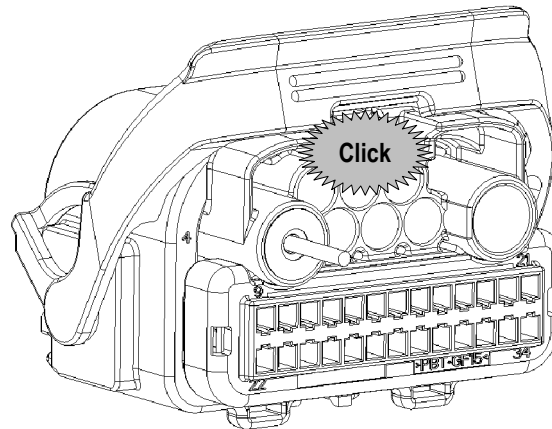

Insert contact until an audible "Click" is heard or felt. Pull slightly on wire to ensure full seating.

Female Contact Assembly Instructions (End)

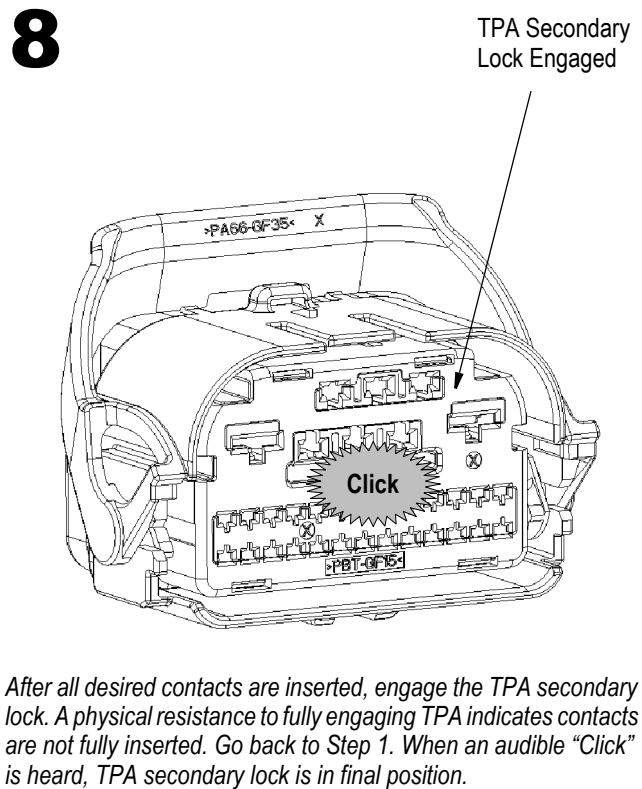
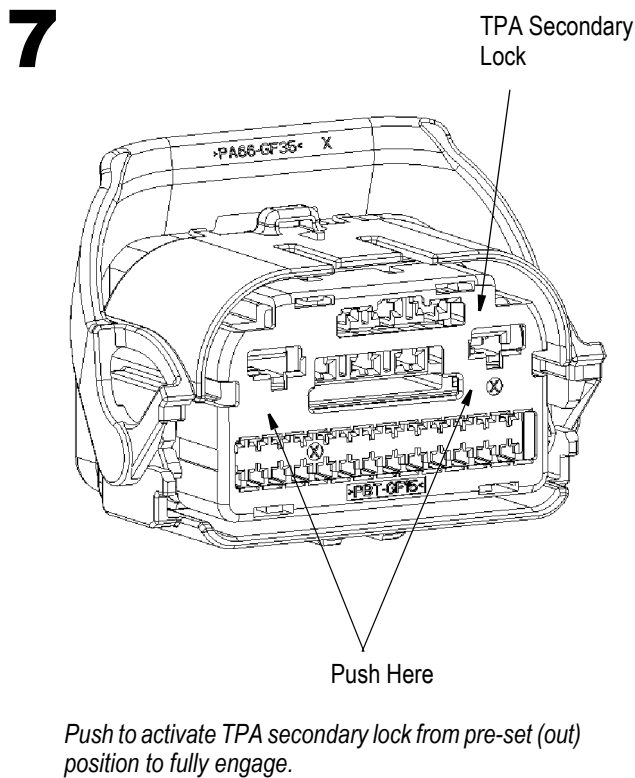
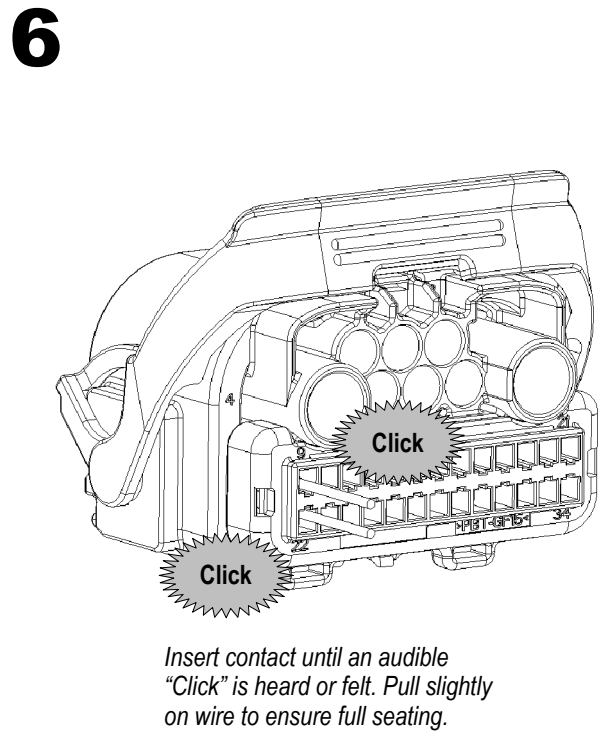
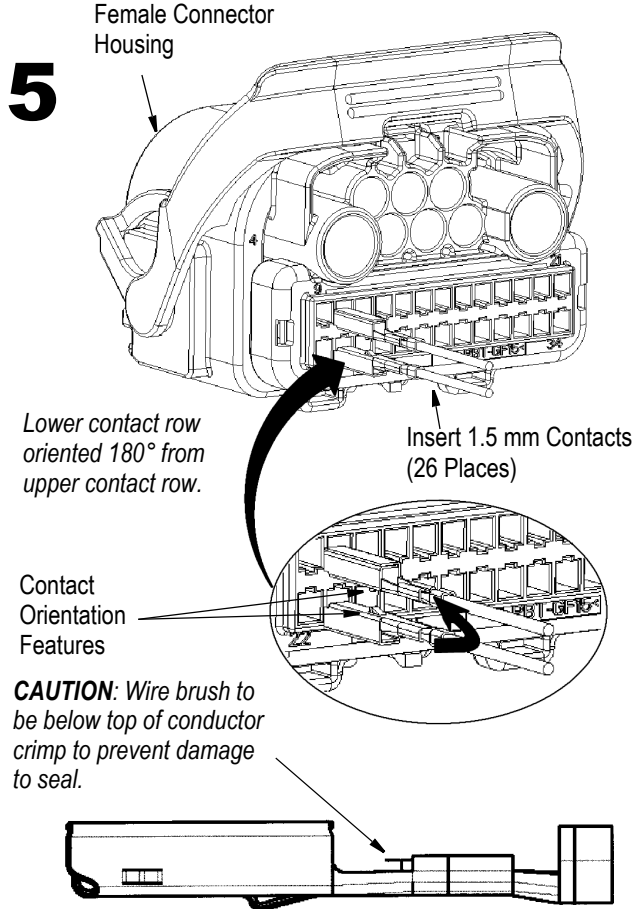

B. Male Contact Assembly Instructions (Cont'd)

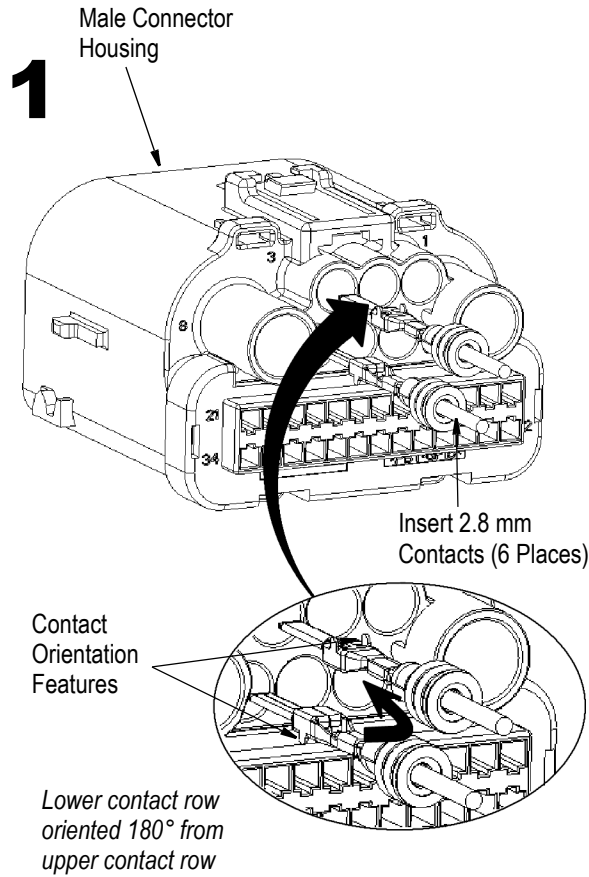

2

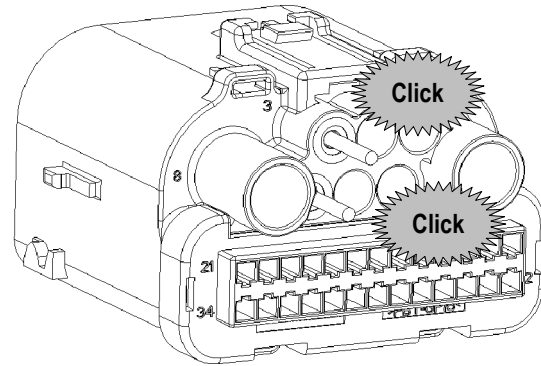

Insert contact until an audible "Click" is heard or felt. Pull slightly on wire to ensure full seating. If resistance is felt prior to full seating, refer to Section "D" to verify connector TPA is in pre-lock position.

3

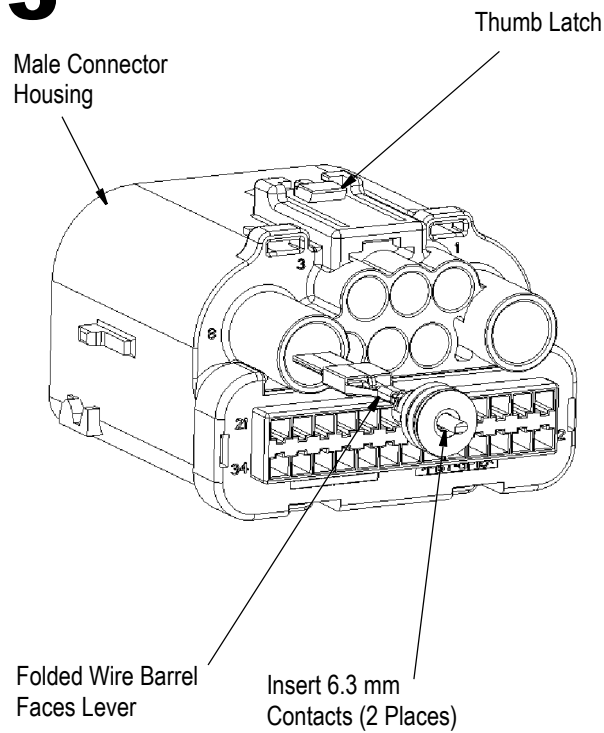

4

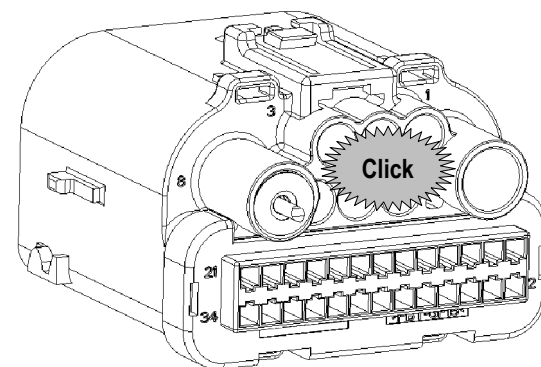

Insert contact until an audible "Click" is heard or felt. Pull slightly on wire to ensure full seating.

Male Contact Assembly Instructions (End)

5

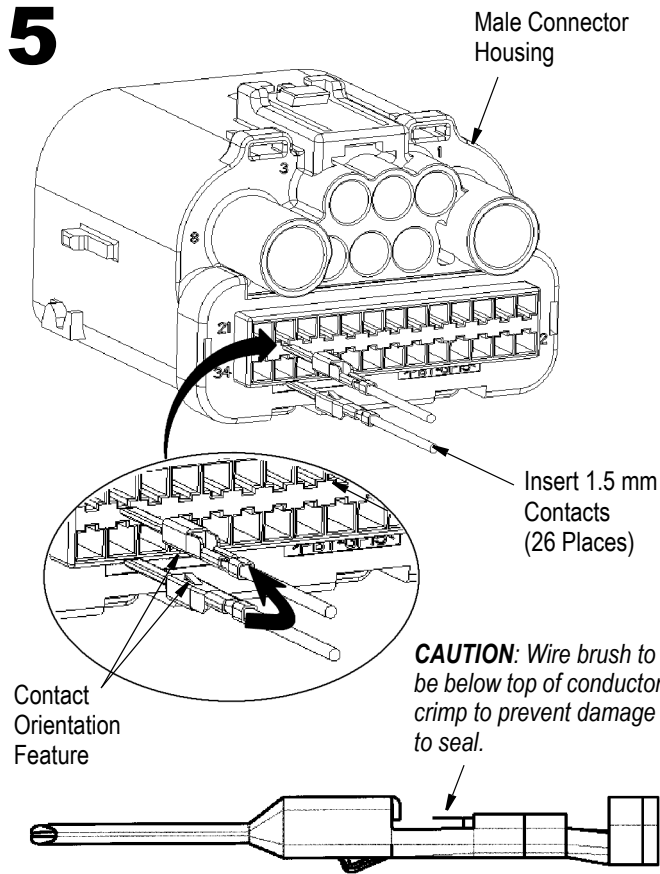

6

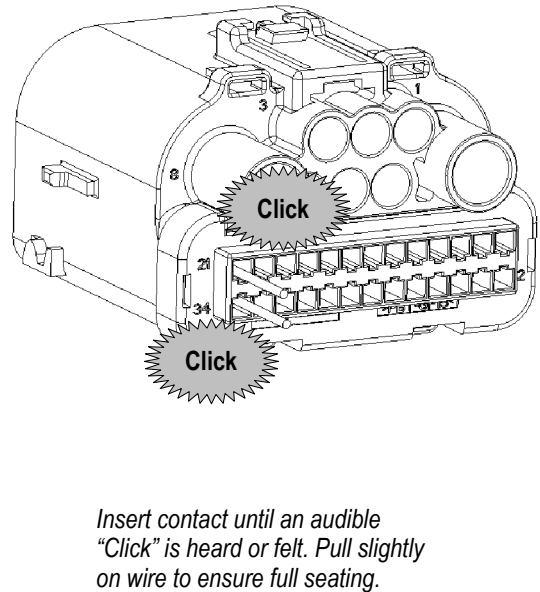

All male terminals should extend through the alignment plate.

Push TPA here to seat TPA without seating alignment plate. A physical resistance indicates contacts may not be fully seated - go back to Step 1.

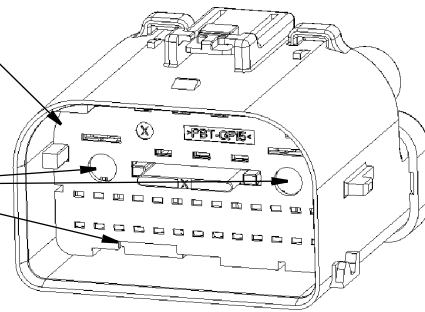

7a

7b

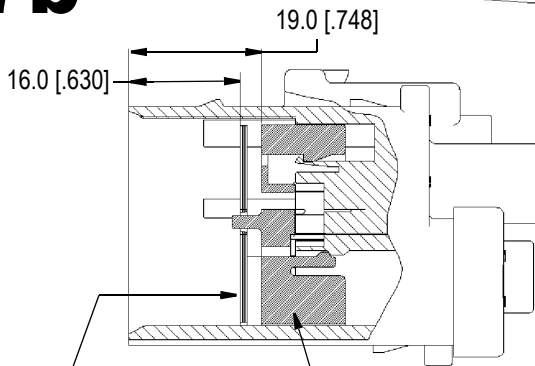

Alignment Plate in Pre-Locked Position TPA in Pre-Locked Position

7c

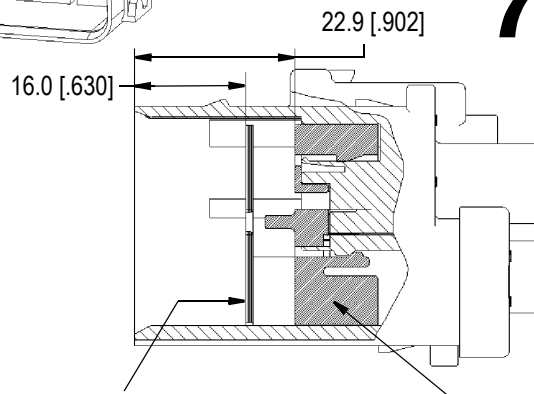

Alignment plate remains in pre-locked position and is seated when fully assembled connectors are mated (Section E). TPA in Fully Seated Position

C. Female Contact Disassembly Instructions (Use Small Screwdriver)

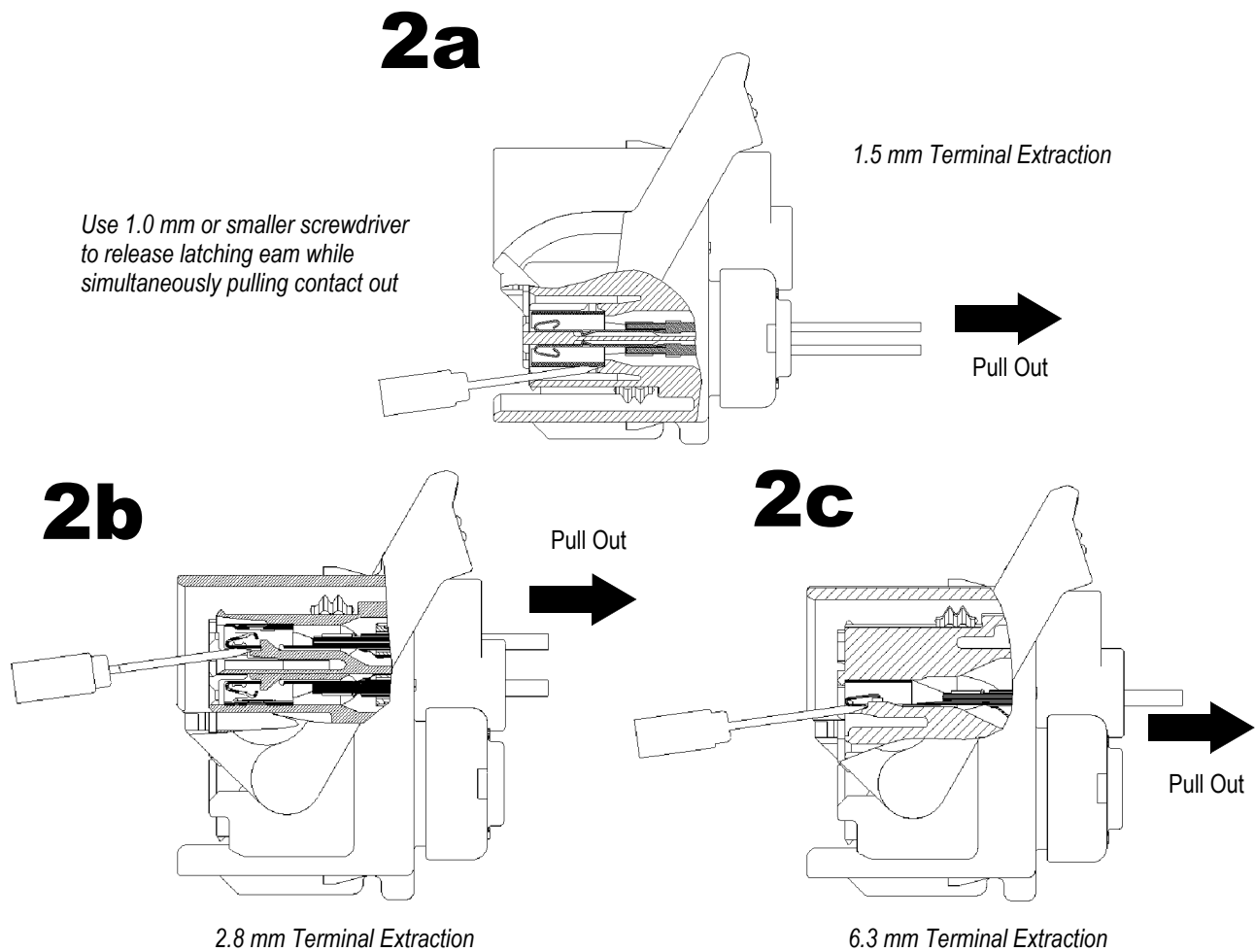
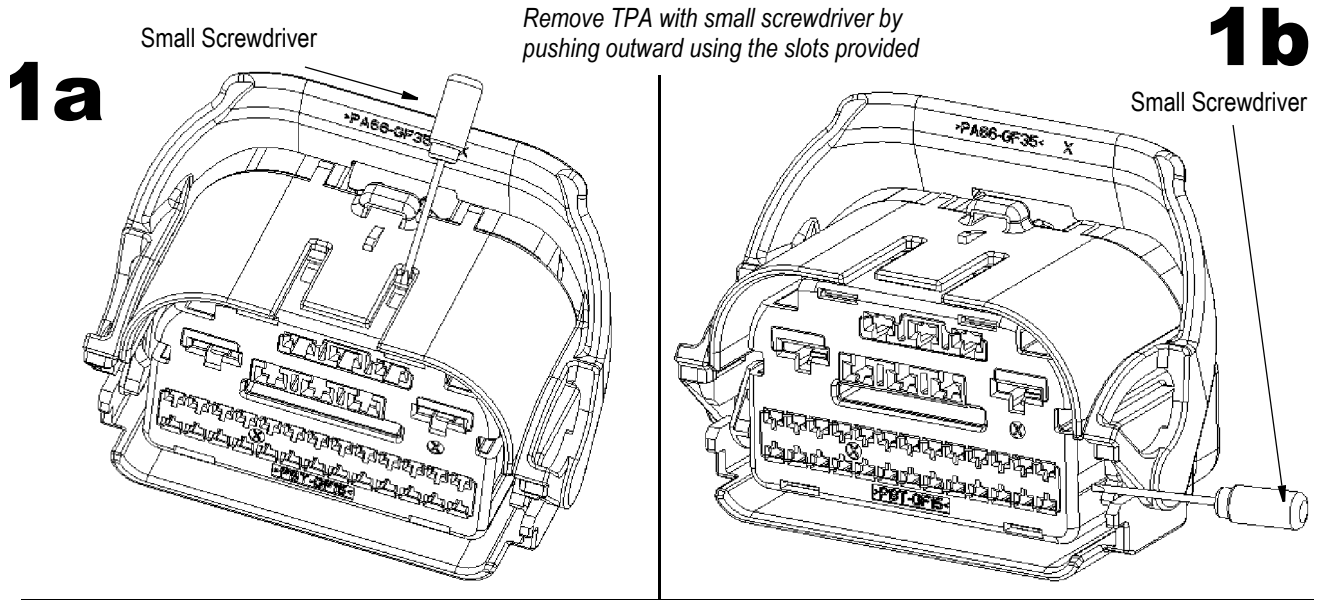

D. Male Contact Disassembly Instructions (Use Pliers and Small Screwdriver) (Cont'd)

1a

Remove the TPA and Alignment Plate

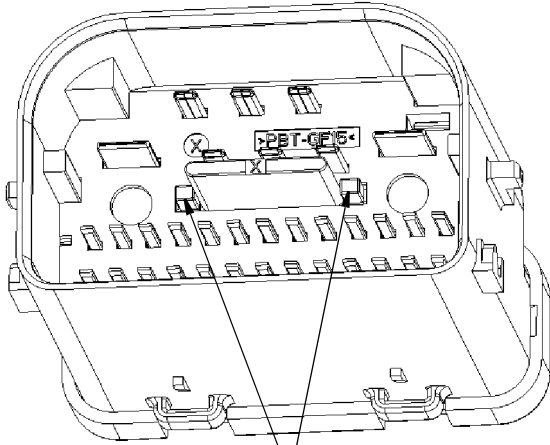

Pull TPA posts with pliers to remove TPA and alignment plate simultaneously

1b

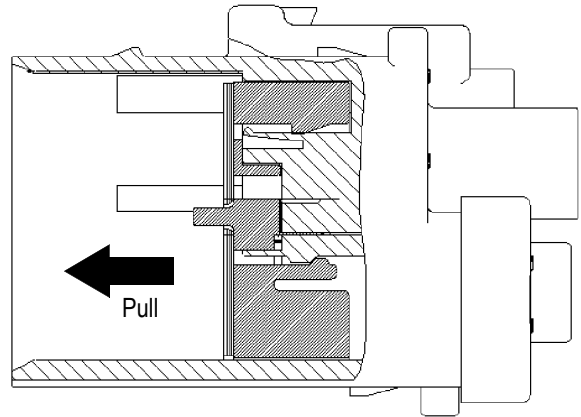

1c

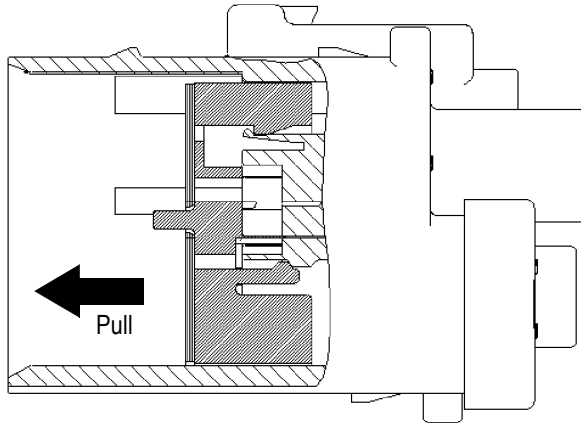

1d

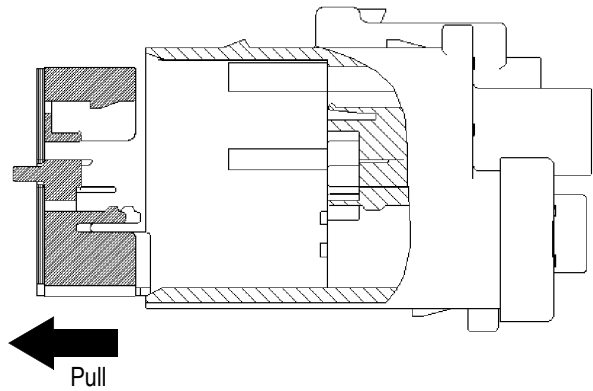

Male Contact Disassembly Instructions (Use Pliers and Small Screwdriver) (End)

2a

Use 1.0 mm or smaller screwdriver to release latching beam while simultaneously pulling contact out.

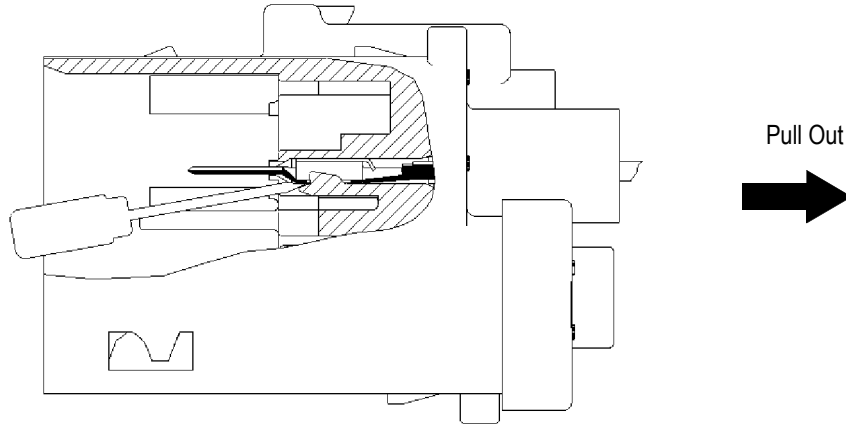

6.3 mm Terminal Extraction

2b

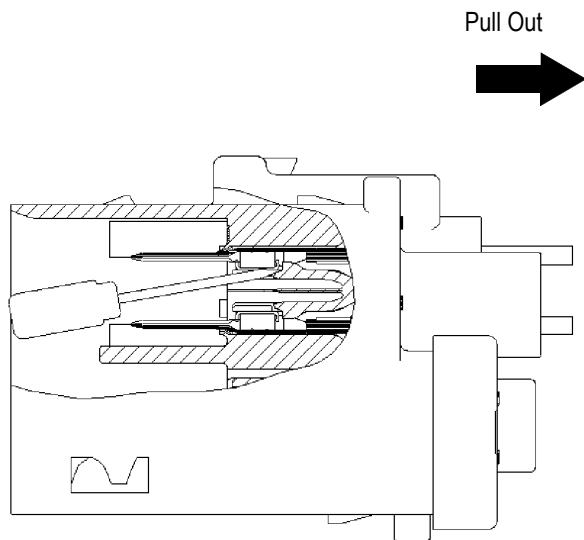

2.8 mm Terminal Extraction

2c

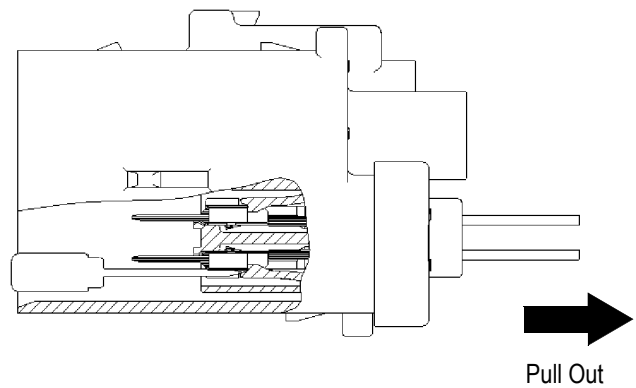

1.5 mm Terminal Extraction

E. Connector Mating Instructions (Cont'd)

1

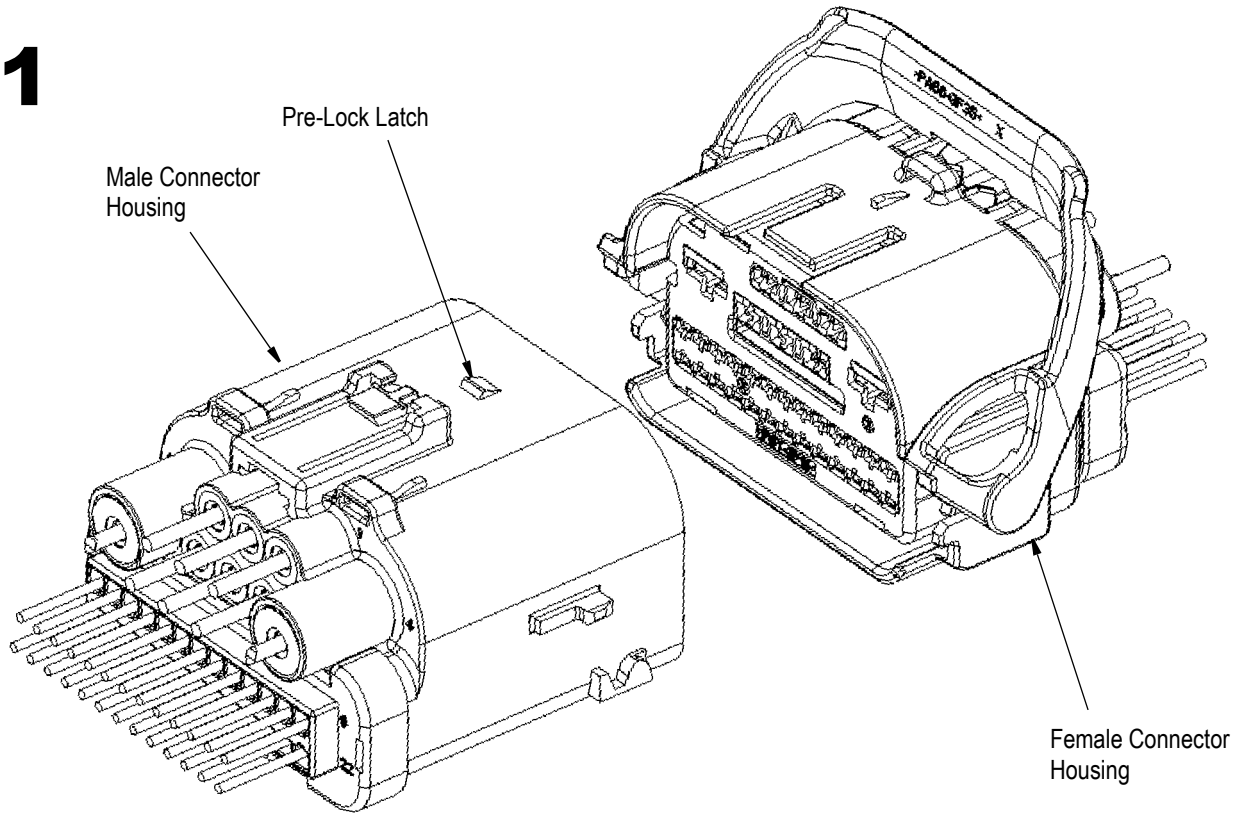

2

Connector must be seated into pre-lock position before lever can swing freely. Connector TPA's must be fully seated prior to connector mating to ensure low mating force and prevent binding.

Audible "click" is heard when connectors are seated in pre-lock position.

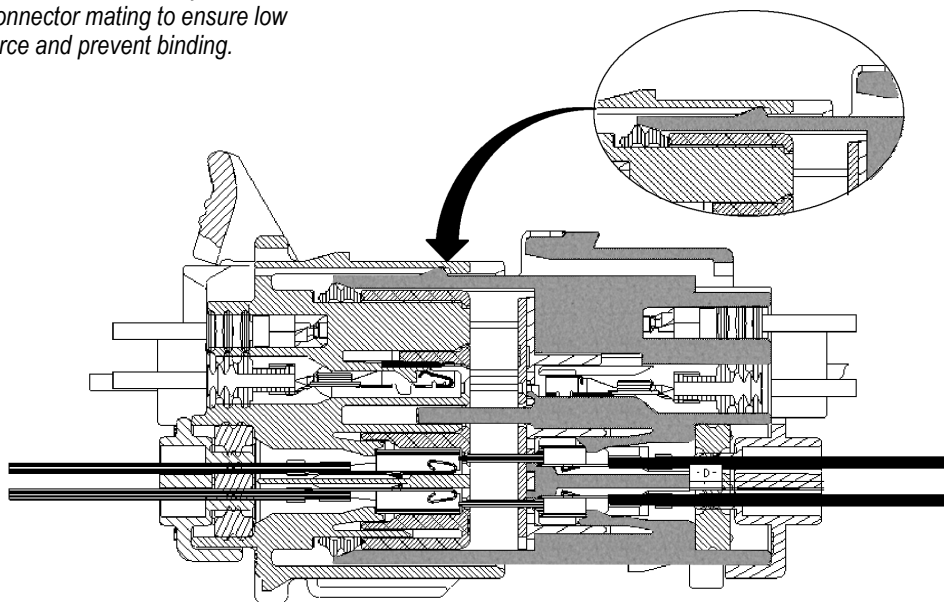

Connector Mating Instructions (End)

3

Activate Lever

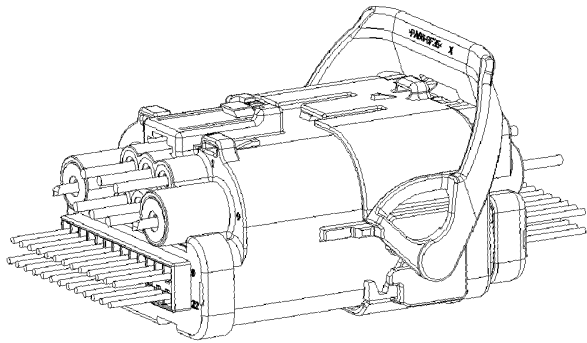
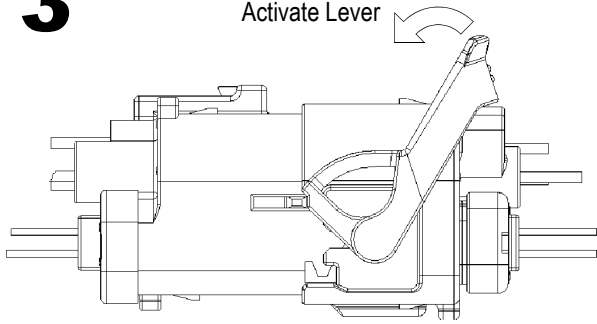

4

Activate Lever

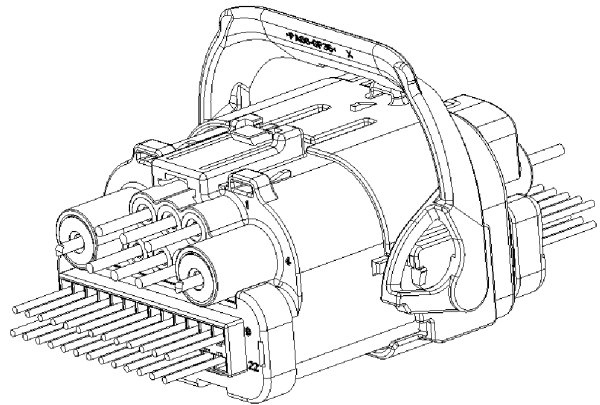
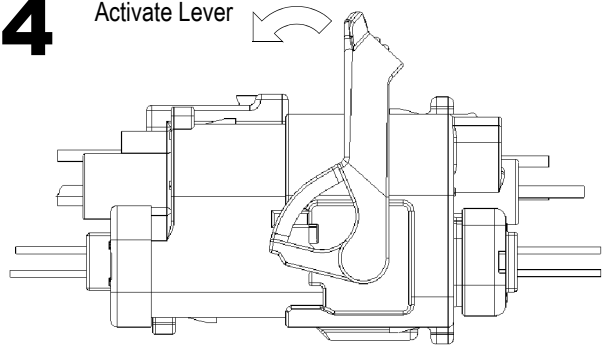

5

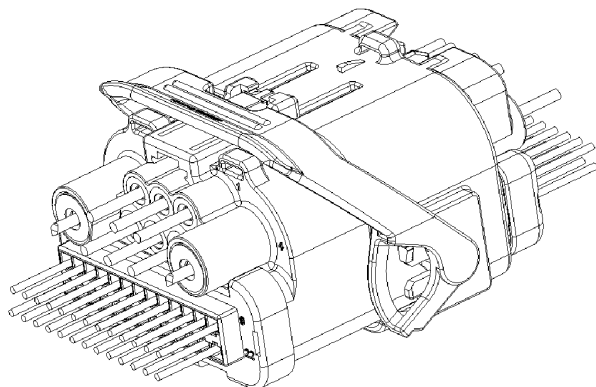
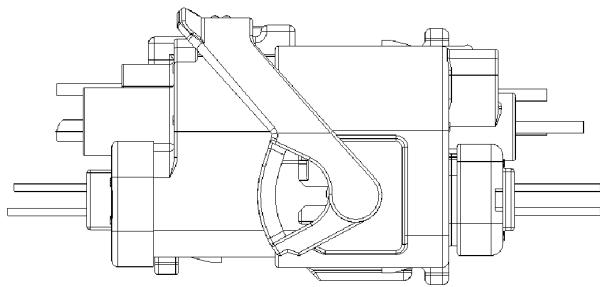

6

Lever Fully Engaged
with Connector Latch

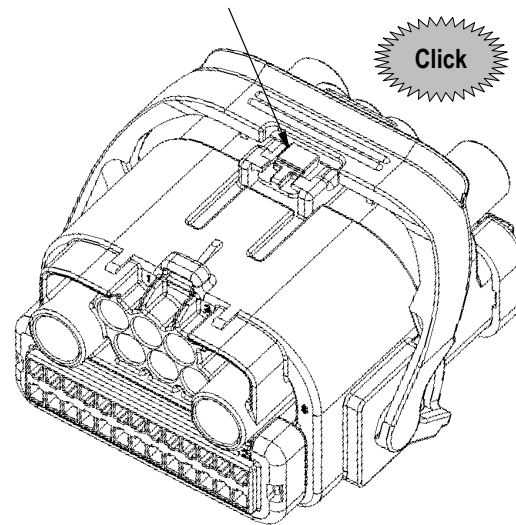

F. Connector Unmating Instructions

1

Press Latch Down to Disengage Lever from Connector

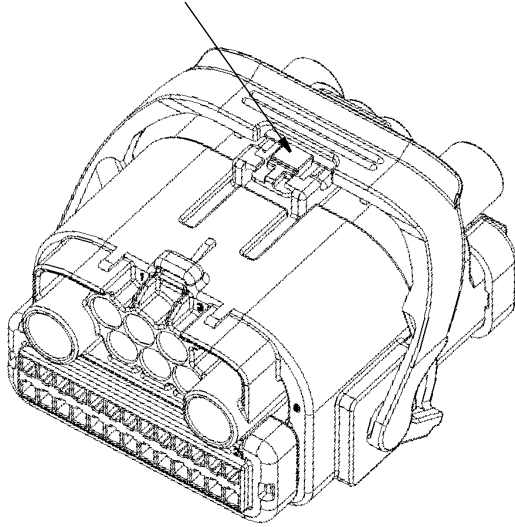

2

Pull Lever Open While Depressing Connector Latch

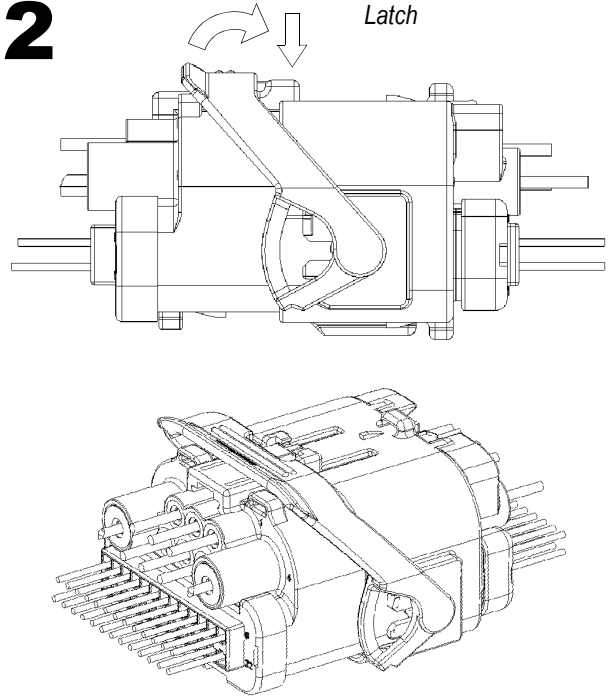

3

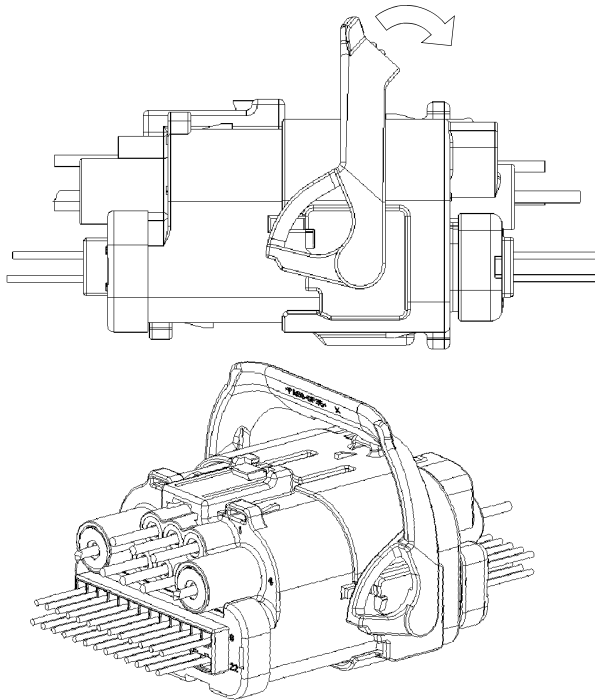

4

The connectors may be unmated when the lever is fully disengaged.

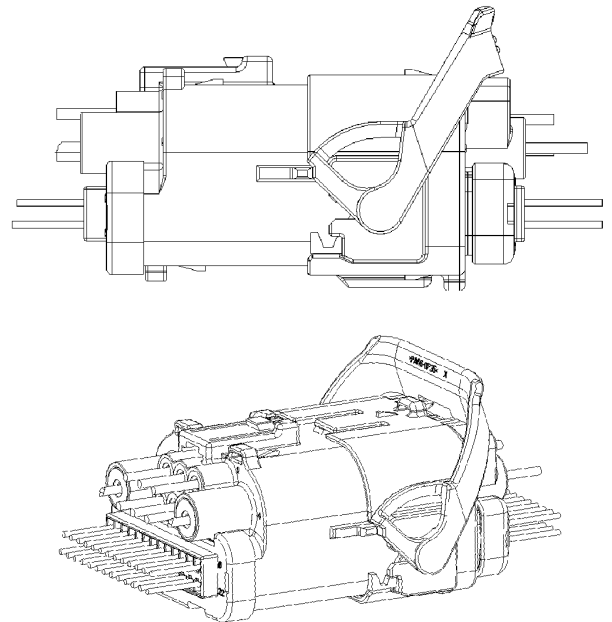

G. Connector Polarization

The 34-Position Hybrid Connectors are color-coded and have keying features to ensure proper polarization.

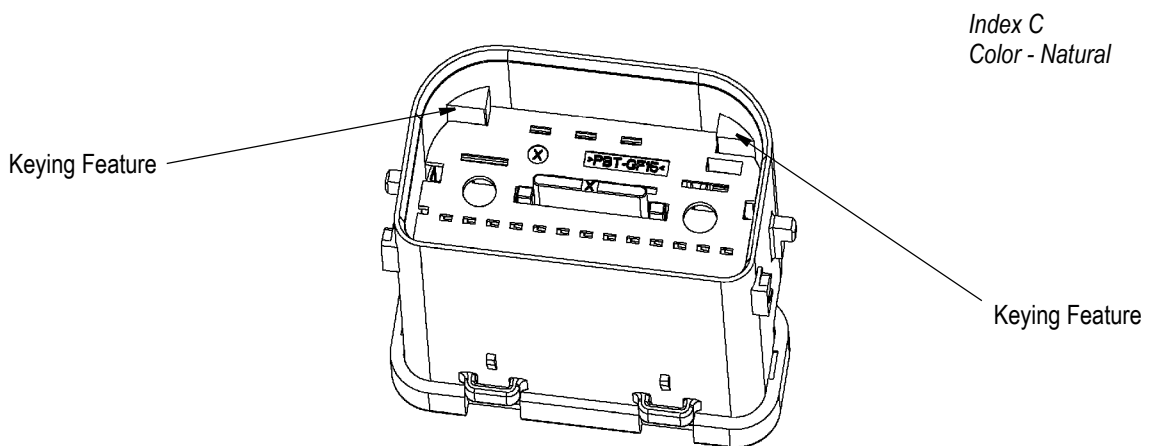
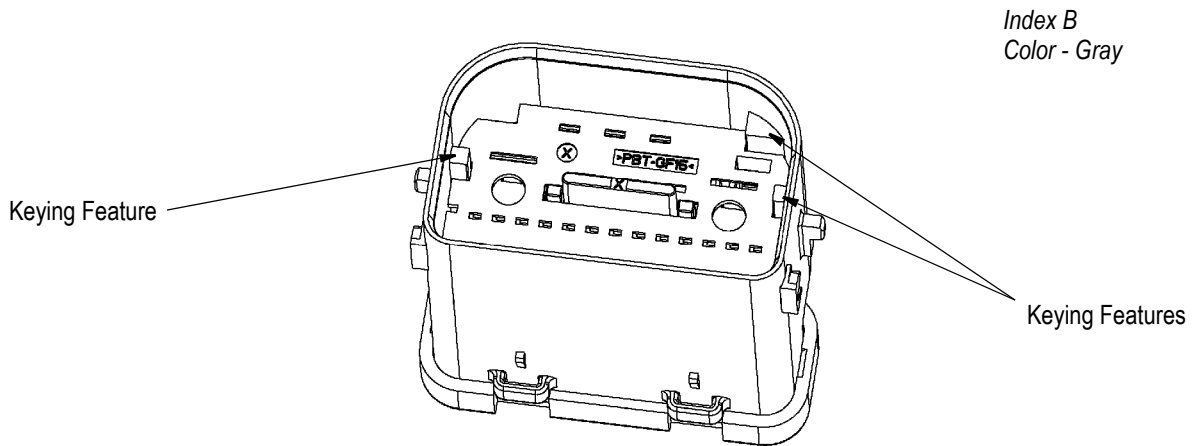
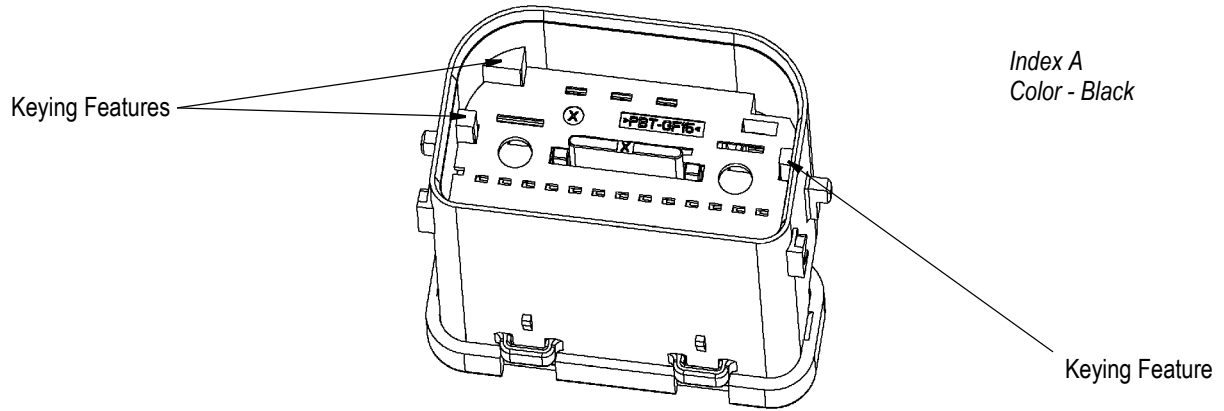

2. REVISION SUMMARY

- Updated format to corporate requirements.