

CUSTOMER HOTLINE 1 800 722-1111

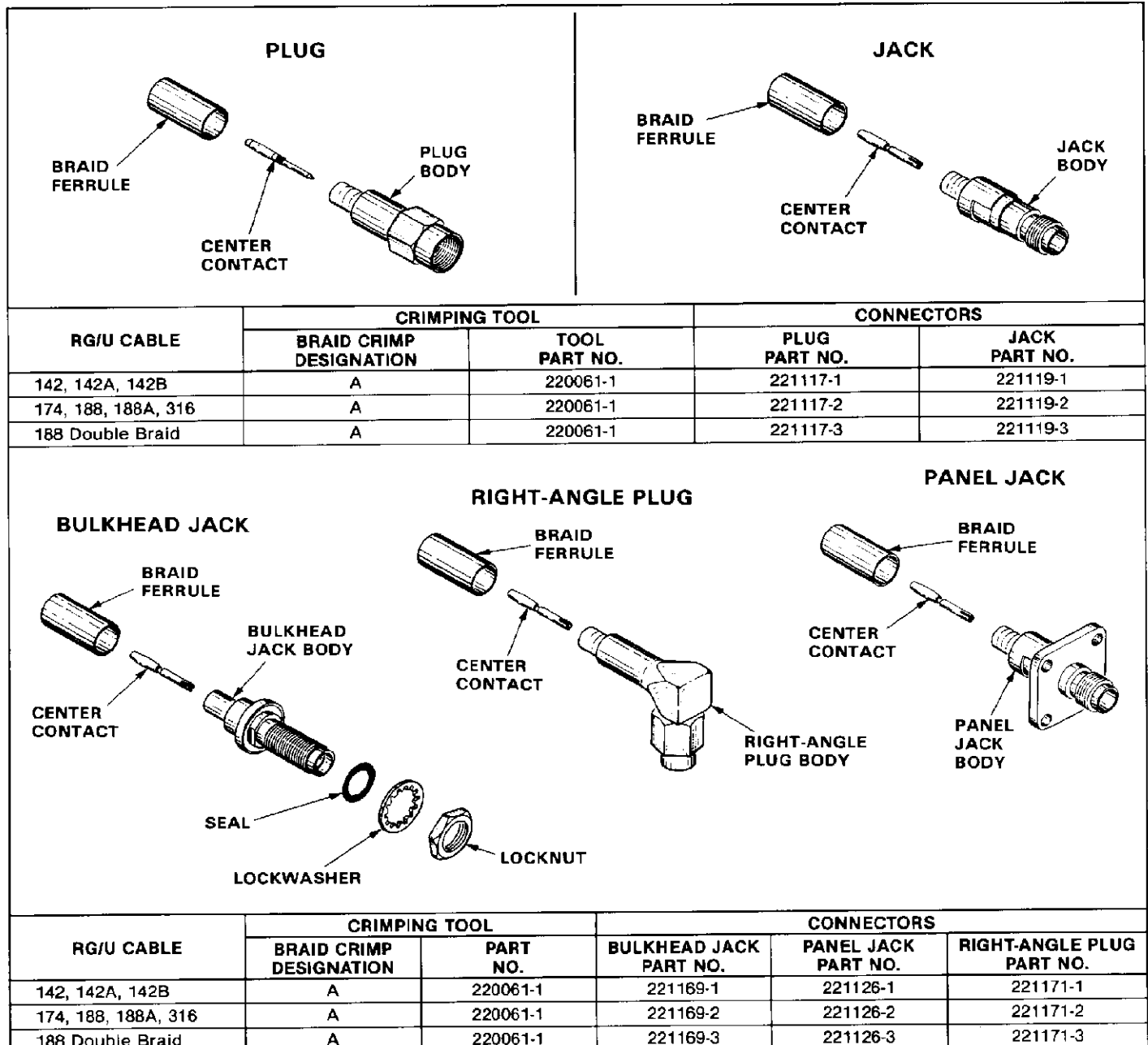

NOTE: FOLLOW THE LETTER DESIGNATION OF RG/U CABLE AS INDICATED. DO NOT USE RG/U CABLE UNLESS SHOWN.

Fig. 1

1. INTRODUCTION

This instruction sheet (IS) covers the use of the AMP SMA Series commercial 50-ohm RF connectors listed in Figure 1. The connectors are terminated to flexible cable. Read these instructions thoroughly before assembling the connectors.

2. DESCRIPTION

The SMA RF connectors consist of a plug, a jack, a bulkhead jack, a right-angle plug, and a panel jack. Each connector features a braid ferrule, body, and center contact. The bulkhead jack connector also features a seal, lockwasher, and locknut.

NOTE All dimensions on this instruction sheet are in inches.

3. ASSEMBLY PROCEDURE

Refer to the chart in Figure 1, select the appropriate cable size and connector, and proceed as follows:

1. Slide ferrule onto cable as shown in Figure 2. Then strip the cable according to the dimensions shown in Figure 3.
2. Crimp center contact using AMP Hand Crimping Tool 220061-1. Refer to AMP Instruction Sheet IS 2392, included with the tool, for specific crimping instructions.
3. Insert center contact into body, making sure braid fits over the support sleeve of the body. Pull back lightly on the cable to make sure center contact is being held captive by the internal locking feature in the connector body.
4. Slide ferrule over braid and crimp ferrule according to instructions in IS 2392.

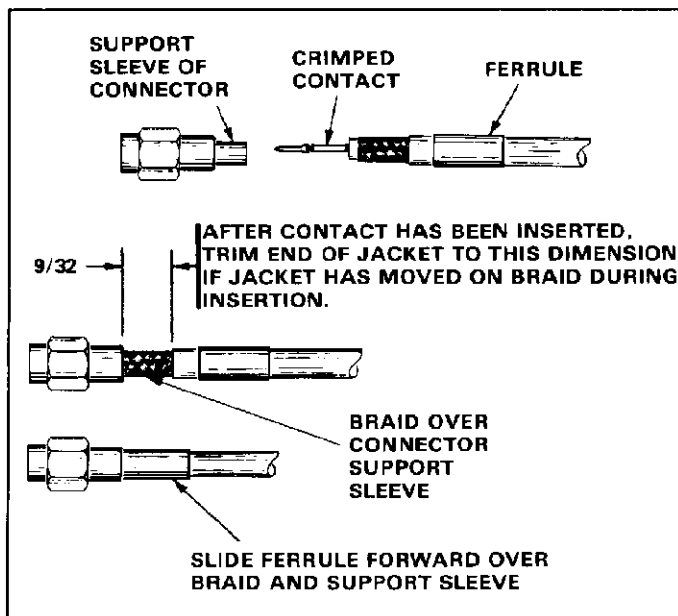

Fig. 2

SMA SERIES RF COMMERCIAL CONNECTORS

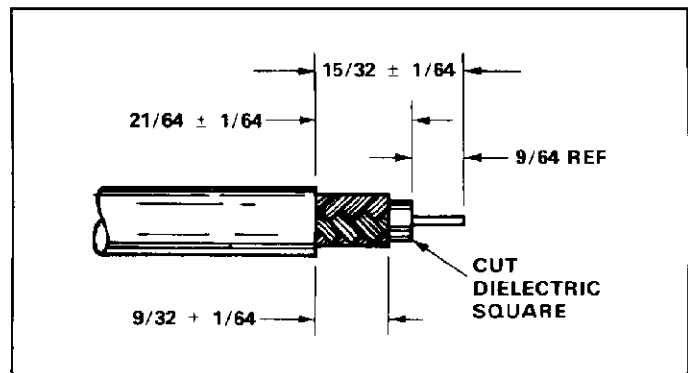

Fig. 3

5. Torque mated members to 7 to 10 inch-pounds.
6. When using bulkhead jack and panel jack connections, refer to the dimensions in Figure 4 to make the panel cutouts.

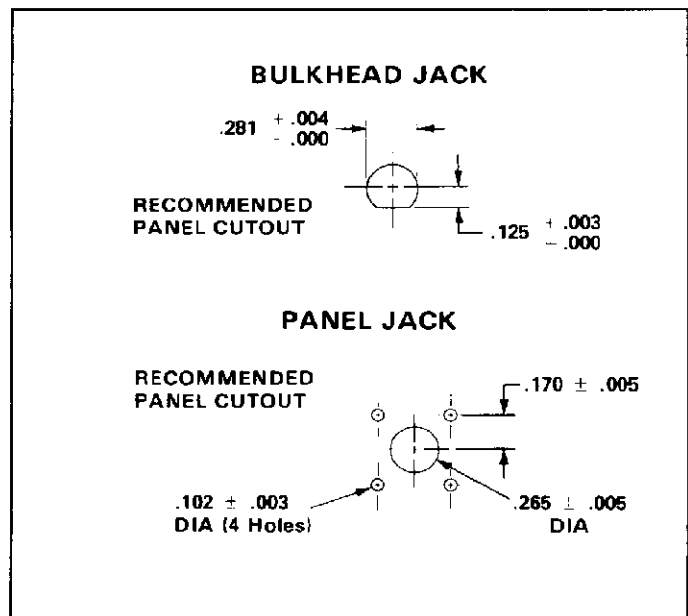

Fig. 4