

TRANSCIVER	TRANSCIVER ASSEMBLIES (Transceiver and Tap Adapter)			
	N SERIES TAP ADAPTER	LOW-PROFILE TAP ADAPTER	BNC "T" TAP ADAPTER	BNC VERTICAL TAP ADAPTER
Full Status Display No. 222062-1	222289-1	222289-2	222289-3	222289-4
No Status Display (PWR† and SQE‡ Indicators) No. 222063-1	222290-1	222290-2	222290-3	222290-4

† Power
‡ Signal-Quality Error Test

Figure 1

1. INTRODUCTION

This instruction sheet describes the installation, testing, and use of the AMP* LAN-LINE Transceiver Assemblies listed in Figure 1. Transceiver specifications and a summary of differences between network standards are also included for reference.

Reasons for reissue are provided in Section 9, REVISION SUMMARY.

2. DESCRIPTION

As shown in Figure 1, AMP offers three types of transceivers. Each type is available with one of four different transceiver tap adapters. Both BNC transceiver tap adapters are used with Thinnet cable. The N-Series and Low-profile tap adapters are designed to be used with standard Ethernet cable. A separate instruction sheet, describing the transceiver tap adapter, is included with the transceiver assembly.

The transceiver has a rugged cast-aluminum case that houses two printed circuit (pc) boards. A 15-position, panel-mounted plug connector and a 15-position receptacle connector are mounted on the central pc board. The transceiver tap adapter plugs into the receptacle connector, and two flat head screws hold the adapter in place. The plug connector attaches to an auxiliary unit interface (AUI) cable, which then connects to the host device (such as a computer terminal or printer).

Transceiver 222062-1 has a "full-status display" which includes these light-emitting diodes (LEDs):

- PWR (Power)
- SQE (Signal-Quality Error)
- XMT (Transmit)
- RCV (Receive)
- CP (Collision Presence)

These LEDs help the system troubleshooter locate node and network problems. While these LEDs may not help the troubleshooter solve complex network problems, they may help to pinpoint simple, but hard-to-find, causes for the problems.

The transceiver has been designed to provide easy enabling and disabling of the SQE (signal-quality error — "heartbeat") test without having to take apart the transceiver. When the heartbeat is enabled, the SQE LED will glow steadily. Refer to Section 4, CONFIGURING THE HEARTBEAT (SQE) TEST.

All LAN-LINE transceiver assemblies are compatible with Ethernet Versions 1.0 and 2.0, as well as the IEEE 802.3 Standard for a 10-Mbps Medium Attachment Unit.

3. INSTALLATION

The transceiver assembly is installed in a network in this order:

1. Connect transceiver tap adapter to coaxial network cable.
2. Connect transceiver with transceiver tap adapter.
3. Connect transceiver to host.

3.1. Connecting the Transceiver Tap Adapter to the Network Cable

For detailed information on connecting the transceiver tap adapter to the coaxial network cable, refer to the instruction sheet included with the transceiver assembly.

3.2. Connecting the Transceiver to the Transceiver Tap Adapter

1. Remove the flat head screws from the transceiver case. Refer to Figure 2.
2. Insert the transceiver tap adapter into the opening in the transceiver. Make sure that the connector pins in the transceiver tap adapter align with the receptacle contacts inside the transceiver.

CAUTION

Do NOT force the transceiver tap adapter into the transceiver; very little force is required.

3. Install and tighten the flat head screws.
4. Test the transceiver assembly using network test equipment.

3.3. Connecting the Transceiver to the Host

The transceiver attaches to the host through an AUI cable, which must be properly matched to the host Ethernet or IEEE 802.3 controller to achieve efficient throughput in the network. Since Ethernet Version 1.0, Version 2.0, and IEEE 802.3 standards require different transceiver cables, proper matching to the controller is critical to network performance.

The transceiver works with any style of transceiver cable. Since cable grounding is done at the host end of the cable, however, proper matching of cable and host is critical. Refer to Section 6, STANDARDS, for additional information on the differences between the standards.

1. Attach the receptacle end of the AUI cable to the transceiver's 15-position plug connector. Lock the receptacle to the plug by moving the slide lock to the "locked" position.

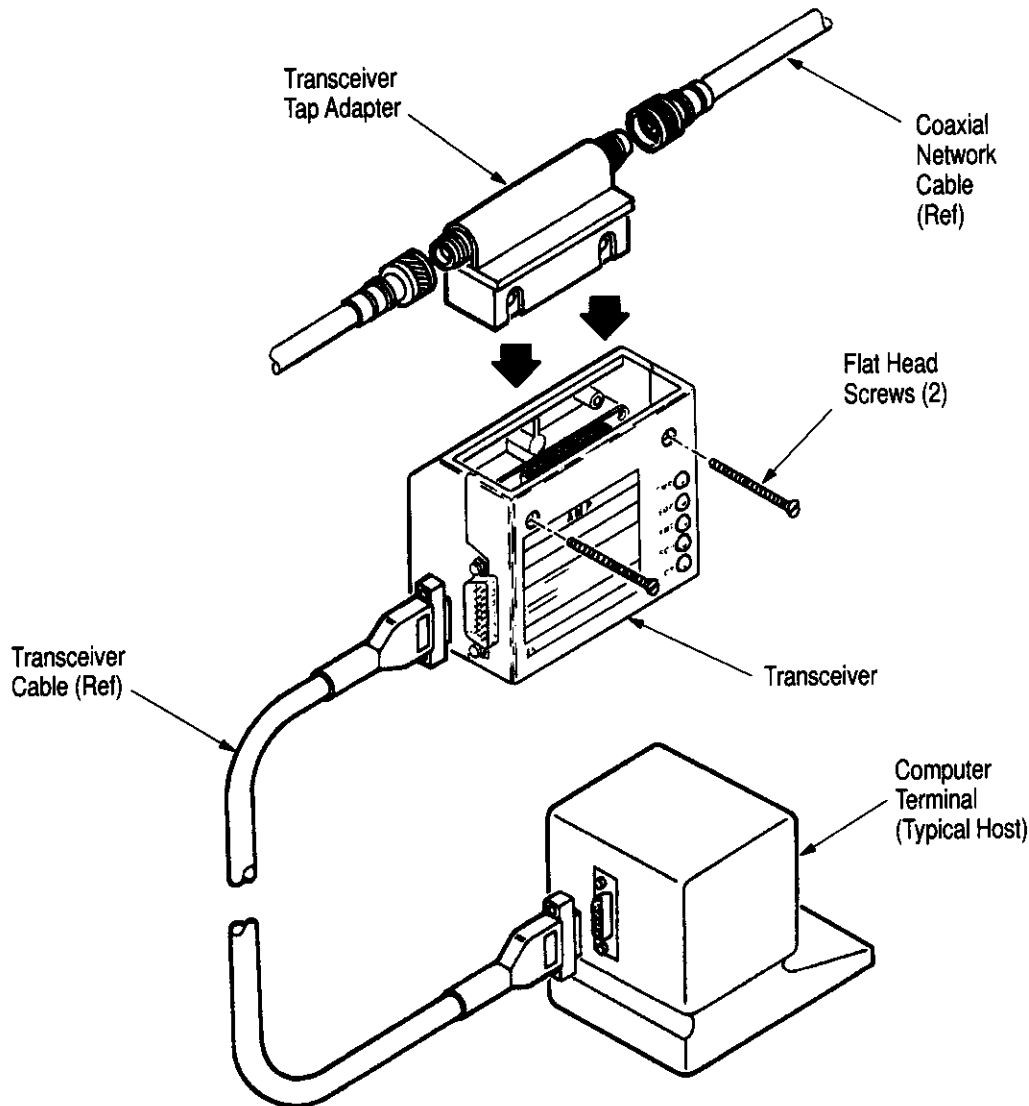

Figure 2

2. Attach the other end of the AUI cable to the 15-position plug connector on the host system, then lock the connector in place.

NOTE

Make sure that the grounding configuration on the host system's 15-position plug connector is the same as the configuration on the transceiver cable. Improper grounding can cause data packets (especially longer packets) to become garbled.

3. Turn on the system. If you are installing Transceiver 222289-[], the full-status display LEDs should show this lighting pattern (refer to Section 4, CONFIGURING THE HEARTBEAT (SQE) TEST for more information):

SQE ("Heartbeat") Enabled:

- PWR "on"
- SQE "on"
- XMT "off," unless host transmits data
- RCV "off" and "on," depending on network traffic
- CP "off" and "on," depending on network traffic and when host transmits data

SQE ("Heartbeat") Disabled:

- PWR "on"
- SQE "off"
- XMT "off," unless host transmits data
- RCV "off" and "on," depending on network traffic
- CP "off" and "on," depending on collision occurrence in network

These lighting patterns indicate that the transceiver has been connected to the Ethernet/IEEE 802.3 network, and that the host has access to the network. Other lighting patterns are shown in Section 5, TROUBLESHOOTING USING THE FULL STATUS DISPLAY INDICATORS.

NOTE

The LEDs are meant to be an aid in troubleshooting and maintenance of the network. Remember, however, that the LEDs are only a rough method of determining network problems, and they should not take the place of more sophisticated LAN test and troubleshooting equipment.

4. CONFIGURING THE HEARTBEAT (SQE) TEST

The heartbeat, or signal-quality error (SQE), test is used to make sure that the collision-presence circuit and path are working. This test is generated by the transceiver after it retransmits a packet that it has received from the host. Since the collision circuitry is critical to the operation of all CSMA/CD networks, it is important to perform this test.

The heartbeat test is not part of the Ethernet Version 1.0 specification. Because of this, Version 1.0 equipment may not work with transceivers that generate the heartbeat signal. IEEE 802.3 specifications state that repeaters complying with IEEE 802.3 must not be attached to transceivers that generate the heartbeat (this is related to a jam signal which prevents repeated collisions from occurring on the network).

For applications where both Ethernet-type and IEEE 802.3-type transceivers are required, AMP offers one unit that meets both needs. To reduce confusion, the unit has an LED that indicates the presence of the heartbeat signal.

It is important that the transceiver be properly set up to work with the Ethernet or IEEE 802.3 controller. If

you have any questions about the configuration, refer to the controller board's user manual. In many cases, Version 1.0-style equipment manuals do not cover the heartbeat test, so if information on the test is not included, set up the transceiver so that heartbeat is not generated.

NOTE

Using heartbeat and non-heartbeat transceivers on the same network does not affect the network performance, since the test involves only the transceiver and the respective host.

NOTE

AMP LAN-LINE Transceivers are shipped with the SQE test signal switched "on." This procedure should only be performed if the transceiver must be operated with the SQE signal turned "off."

To set up the heartbeat test:

1. Disconnect the transceiver cable from the transceiver.
2. Remove the transceiver from the transceiver tap adapter.
3. Hold the transceiver with the rectangular opening up and the label on the case away from you. The side of the case with the Status LEDs should face away from you.
4. Move the switch to the appropriate position to turn the SQE test signal "on" or "off" as shown in Figure 3.
5. Reconnect the transceiver to the transceiver tap adapter.
6. Reconnect the transceiver cable.
7. When power is "on" at the host system or repeater, transceivers that have the heartbeat set to "on" will display a lighted SQE LED. If the heartbeat is set to "off," the transceiver's SQE LED will not be lighted.

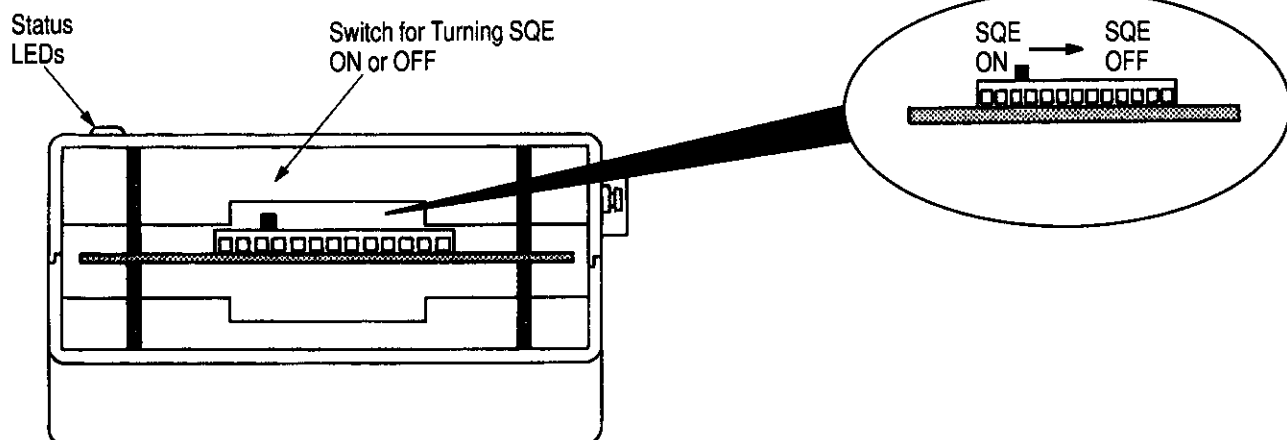

Figure 3

5. TROUBLESHOOTING USING THE FULL STATUS DISPLAY INDICATORS

This section describes potential error conditions that might occur during network operation. The status display indicators (LEDs) on Transceiver 222062-1 provide a simple method of detecting many network and node errors.

The SQE LED is not included in this description. This LED lights when SQE is "on", and remains dark when SQE is "off."

To check the following conditions, a host system must be attached and it must be transmitting data packets.

Condition 1 — No Status Display LEDs "On"

Probable Cause:

- Host system power is "off."
- Transceiver cable is not properly connected.
- Transceiver power pair (pins 6 and 13) not properly connected.

Condition 2 — PWR (Power) "on" XMT (Transmit) "off" RCV (Receive) "on" (steady glow) CP (Collision) "on" (steady glow)

Probable Cause:

- Transceiver tap adapter not making contact with center conductor on coax (open).
- Test equipment on network is producing a steady collision signal.

Condition 3 — PWR (Power) "on" XMT (Transmit) "off" RCV (Receive) "off" CP (Collision) "on"

Probable Cause:

- Test equipment on network is producing a steady collision signal.

Condition 4 — PWR (Power) "on" XMT (Transmit), RCV (Receive), and CP (Collision) flashing at the same time.

This display is normal if SQE is "on" and the host is transmitting. If data is not transmitted properly, check the following:

Probable Cause:

- "Open" in coaxial cable.
- Intermittence in tap; check connection. If other transmitting stations show the same condition, there is a network problem. If other stations do not show the same condition, there is a node problem.
- An incorrect transceiver cable is being used or is paired improperly.

Condition 5 — PWR (Power) "on" XMT (Transmit) flashing RCV (Receive) "on" or "off" CP (Collision) "off"

Probable Cause:

- Collision detector "on"; controller is not properly deferring. This is a condition caused by the test equipment, creating a steady collision signal.
- Collision path through the transceiver cable is broken.

The source of the problem (with a node or with the network) can be determined by checking the LEDs on more than one transceiver. Similar indications at more than one transceiver show a network problem. Indications at only one station show a node problem (this is only a rule of thumb, and it may not apply in every case).

6. STANDARDS

As shown above, the Ethernet and IEEE 802.3 standards are not the same. While Ethernet Version 1.0 and an IEEE 802.3 host can normally coexist and communicate properly on one network, there are sometimes differences that could cause network problems. The important link is the overall transceiver-to-host integrity. Figure 4 shows some of these differences between standards. If you have questions concerning these standards, contact your AMP Representative.

ITEM	NETWORK STANDARD		
	V1.0	V2.0	IEEE 802.3
Transceiver Cable	Three 22 AWG pairs	Four 20 AWG pairs	Four 20 AWG pairs
	One 20 AWG inner and outer shield common at backshell and pin no. 1	Shield common at backshell and pin no. 1	Inner and outer shield isolated from each other
			Outer shell at backshell, inside at pin no. 4
			Indented male connector for better electrical connection
Transceiver	Full step	Half step	Half step
SQE	No heartbeat	Heartbeat	Heartbeat●
Grounding	Pin no. 1	Pin no. 1	Pin nos 1, 4, 11, and 14, ground indents on male connector, jabber latching
Repeater	No requirements	No requirements	Redundant collision protection using jam sequence; separates excessive collision segment from network

● Except when attached to 802.3 repeater.

Figure 4

6.1. Half-Step/Full-Step Signaling (Figure 5)

With full-step signaling, the idle state of the signal potential is nonzero. The first transition, then, changes the signal voltage by the full peak-to-peak signal amplitude.

With half-step signaling, the signal voltage remains at zero until the data is sent. The first transition from the inactive state at the beginning of the packet changes the voltage by only one-half of the peak-to-peak signal amplitude.

Half-step signaling has no DC component which could cause skew during the early part of the preamble of the packet. Signal skew is caused by DC coupling used in some interface circuits.

6.2. Connector Ground Pin

On cables used in IEEE 802.3, the shield is connected only to the connector shell. The plug connectors have a tin-plated shell with ground indents, and the receptacles also use tin-plated shells.

On cables used in Ethernet 1 and 2, pin no. 1 is tied to the connector shell and cable shield.

Half-Step Signal (IEEE 802.3)

NOTE: Idle state is zero.

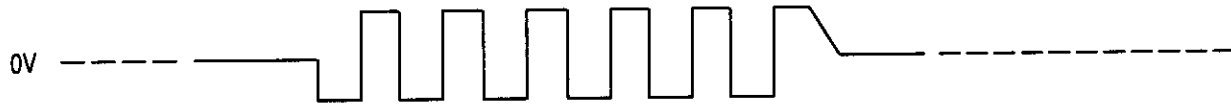

Full-Step Signal (Ethernet 1.0)

NOTE: Idle state is nonzero.

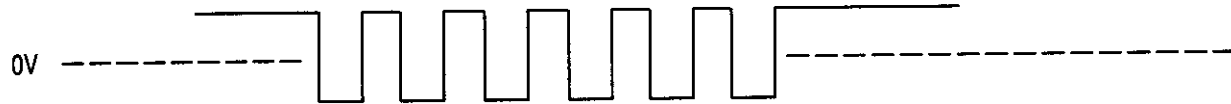

Figure 5

6.3. Differences in the Coaxial Cable

There is no significant difference between IEEE 802.3 and Ethernet 1 and 2 specifications in this area; the two specifications are compatible.

Isolation: 2000 Vac, 50/60 Hz, applied between the shield of the coaxial cable and the shield of the transceiver cable or transceiver case shield.

7. SPECIFICATIONS

7.1. Environmental Factors

Operating Temperature Limits:
5° to 55° C (41° to 131° F)

Temperature Limits When Not Operating:
-20° to +90° C (-4° to +194° F)

Humidity Tolerance:
5% to 95% non-condensing

Electromagnetic Susceptibility:
The transceiver will operate properly in the following externally applied fields:

2 Volts/Meter, 10 KHz to 30 MHz
5 Volts/Meter, 30 MHz to 1000 MHz

as well as an applied transient with slope equal to 1 V/nS from coax shield to transceiver case.

Electromagnetic Radiation:
Meets FCC Part 15, Subpart J, Class A and B limits.

NOTE IT IS THE RESPONSIBILITY OF THE PERSON WHO SELLS THE SYSTEM OF WHICH THE AMP LAN-LINE TRANSCEIVER MAY BE A PART TO ENSURE THAT THE TOTAL SYSTEM MEETS THE ALLOWED LIMITS OF CONDUCTED AND RADIATED EMISSIONS.

7.2. Interface

Figure 6 shows the transceiver physical interface to the transceiver cable. The pin assignments are:

Pin 1	Logic Ref	Pin 8	Logic Ref
2	Collision +	9	Collision -
3	Transmit +	10	Transmit -
4	Logic Ref	11	Logic Ref
5	Receive +	12	Receive -
6	Power Return	13	Power
7	N/C	14	Logic Ref
		15	N/C

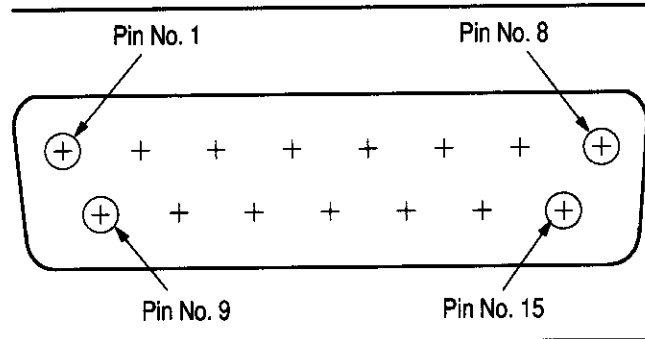

Figure 6

7.3. Federal Communications Commission (FCC) Notices

For Transceivers 222062-1 & 222063-1:

This equipment generates and uses radio-frequency energy. If not installed and used in strict accordance with the manufacturer's instructions, the equipment may cause interference to radio and television reception. The equipment has been type-tested and

found to comply with the limits for a Class B computing device in accordance with the specifications in Subpart J of Part 15 of FCC Rules. These specifications are designed to provide reasonable protection against such interference when the equipment is operated in a residential environment. There is no guarantee, however, that interference will not occur in a particular installation. If the equipment does cause interference to radio or television reception, which can be determined by turning the equipment off and on, the user is encouraged to try to correct the interference with one or more of the following measures:

- Re-orient the receiving antenna.
- Relocate the computer with respect to the receiver.
- Move the computer away from the receiver.
- Plug the computer into a different outlet so that computer and receiver are on different branch circuits.

If necessary, the user should consult the dealer or an experienced radio/television technician for additional suggestions. The user may find the following booklet prepared by the Federal Communications Commission helpful:

"How to Identify and Resolve Radio TV Interference Problems."

This booklet is available from the U.S. Government Printing Office, Washington, DC 20402 — Stock No. 004-000-00345-4.

Notice

To insure FCC compliance and proper operation of the AMP LAN-LINE Transceiver, SHIELDED transceiver cables must be used.

7.4. CE Compliance

For Transceivers 222062-1, 222063-1, and 413692-1

This equipment complies with the following standards:

EN 55022 Class B, EN 50082-1

8. TRANSCEIVER SPECIFICATIONS

RECEIVER SECTION	TYPICAL VALUE	WORST-CASE VALUE
Leakage Current, μ A	0	-5 to +5
Input Impedance, $k\Omega$	>250	>100
Coax Cable Tap Capacitance, pf	3.5	4
Delay Time, Input to Output, ns		
Turn On	250	500
Steady-State	20	50
Waveform Symmetry, ns	± 1	± 1 to 2
Output Voltage, mV	± 670	± 550 to 850

TRANSMITTER SECTION	TYPICAL VALUE	WORST-CASE VALUE
Output Current, mA		
AC Component	41	38 to 44
DC Component	41	38 to 44
Waveform Symmetry, ns	± 1	± 2
Delay Time, Input to Output, ns		
Start-Up	100	200
Steady-State	30	50
Signal Spectrum Harmonic, dB		
Second	-27	-20
Third	-27	-20
Fourth	-40	-30
Fifth	-40	-30
Sixth	-50	-40
Seventh	-50	-40
Higher-order	-57	-50
Input Impedance, Ohms		
Differential	78	77.2 to 78.8
Common-Mode		greater than 20.0
Frequency Range, MHz	2 to 30	2 to 30
Common-Mode Voltage		
Range at Input	0 to 30	0 to 5
Input Voltage Required		
for Operation, mV	± 90	± 150

COLLISION DETECTOR	TYPICAL VALUE	WORST-CASE VALUE
Turn-On Delay, ns	350	900
Output Frequency, MHz	10	9 to 11
Turn-Off Delay, ns	500	2000
Collision DC Threshold, Vdc	- 1.5 to - 1.6	
Interframe Test Signal (optional)		
Delay, ns	700	600 to 1000
Duration, ns	800	600 to 1000
Output Voltage, mV	± 670	± 550 to 850
Jabber Control Timeout, ms	25	20 to 35
Reset Time, ms	420	340 to 500

POWER SUPPLY		
Input Voltage, Vdc	12	9.5 to 16.0
Source Resonance	—	4 Ω Max
Current, mA	225	450

SERVICE	
MTBF, Hours	200,000
MTTR, Hours	.25

9. REVISION SUMMARY

Since the previous release of this sheet, the following changes were made:

Per EC 0990-0322-97:

- Added CE logo and (Refer to Section 7.4) to Figure 1.
- Deleted obsolete part numbers in Figure 1.
- In Section 7.3, deleted information for Transceiver 222061-1.
- Added Section 7.4, CE Compliance.