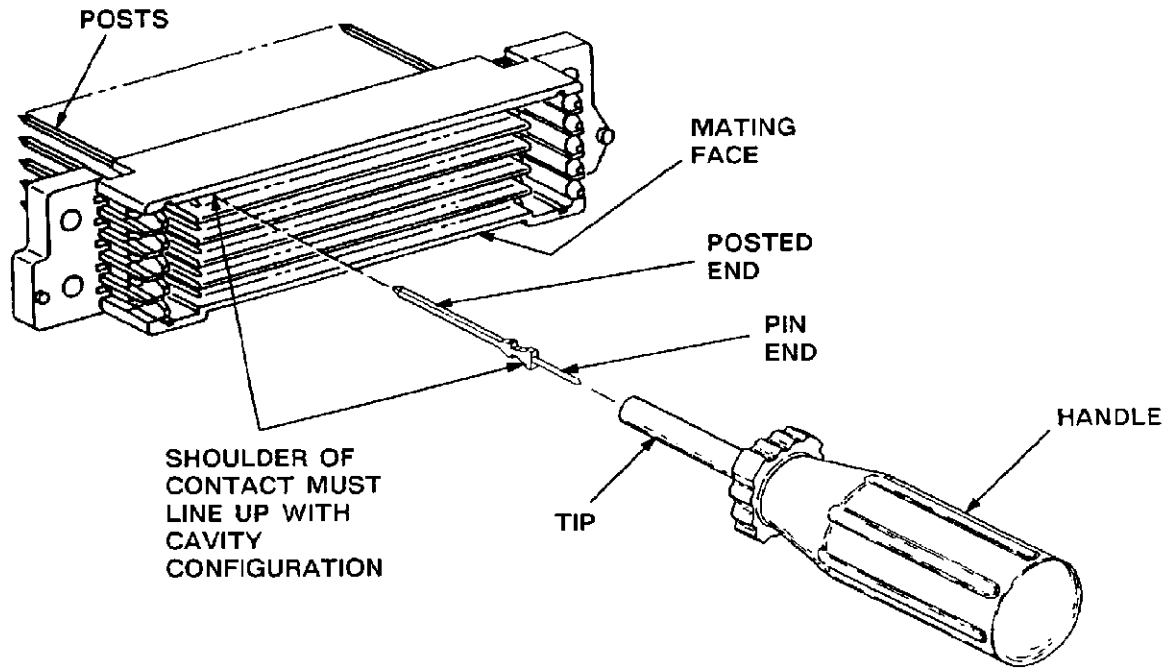

**AMP**AMP INCORPORATED  
HARRISBURG, PA 17105AMP\* INSERTION TOOL 58347-1  
FOR  
AMP WIRE INTEGRATION UNIT

REDUCED FOR PACKAGING

**IS 9399**CUSTOMER HOTLINE  
1 800 722-1111RELEASED  
4-18-88

## PART NUMBER

INSERTION TOOL	REPLACEMENT CONTACT	NUMBER OF POSITIONS	RECEPTACLE ASSEMBLY
58347-1	213400-3	30	213395-1
		75	213396-1

Fig. 1

**1. INTRODUCTION**

This Instruction Sheet (IS) covers AMP Insertion Tool 58347-1 which is designed to insert AMP Replacement Contact 213400-3 into empty cavities of AMP Receptacle Assemblies; the receptacle assemblies are part of the AMP Wire Integration Unit covered by AMP Instruction Sheet IS 9320. See Figure 1 for part numbers. Contact 213400-3 is compatible with any receptacle assembly and is inserted through the mating face.

**NOTE**

All dimensions on this instruction sheet are in inches.

Read these instructions thoroughly before using the tool.

**2. DESCRIPTION**

The tool is a one-piece item that features a metal insertion tip and a plastic handle. The tool part number appears on the handle portion. See Figure 1.

**3. INSERTION PROCEDURE**

The steps which follow are recommended to insert a contact into an empty cavity:

1. Orient the replacement contact so that its shoulders line up with the rectangular configuration of the empty cavity.
2. Push the contact into the cavity by hand until it holds itself in place.
3. Position the insertion tool tip over the pin portion of the contact and — keeping the tool aligned with the contact and cavity — seat the contact, using a steady, even force.

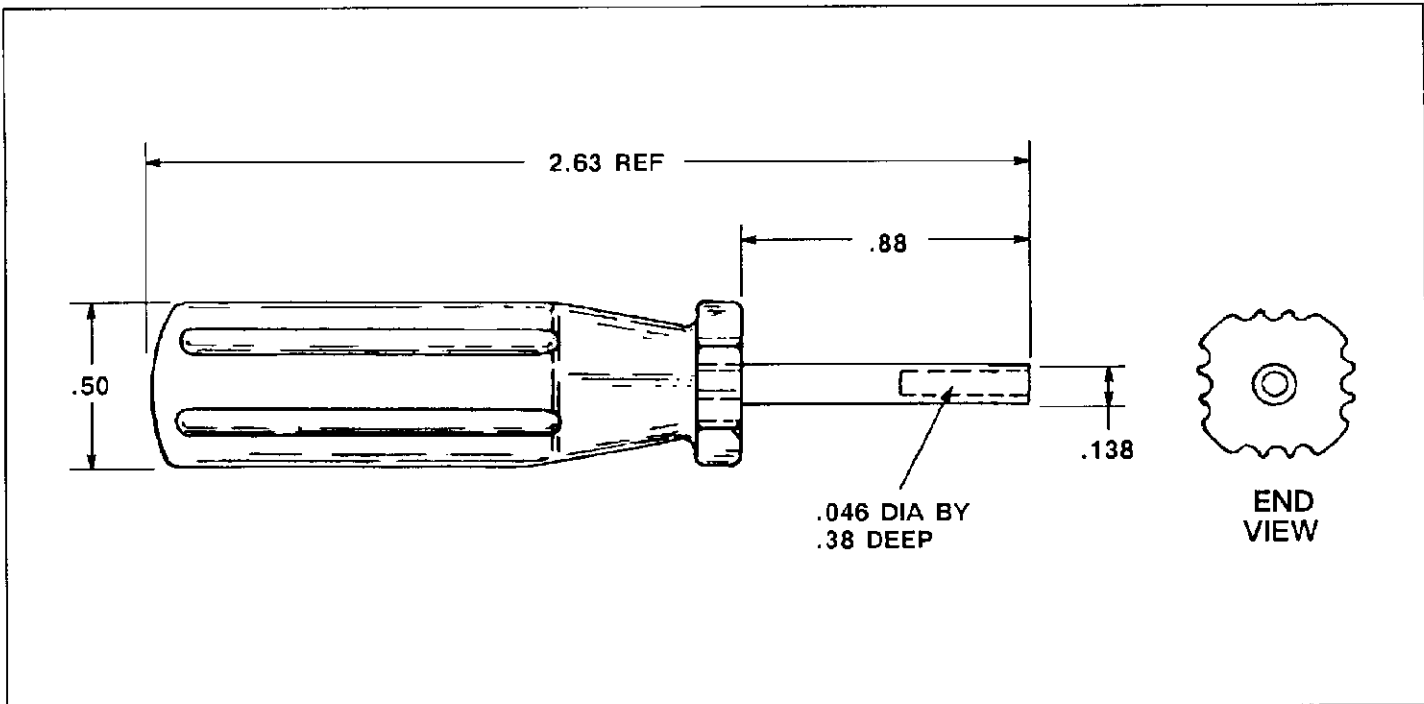

Fig. 2

#### 4. INSPECTION

We recommend that you inspect the tool immediately upon arrival to ensure that the tool has not been damaged in shipment. We also recommend periodic inspection of the tool for damage that may occur in use.

The dimensions shown in Figure 2 include the maximum tolerances.

Additional tools can be purchased from:

AMP Incorporated  
P.O. Box 3608  
Harrisburg, PA 17105-3608