

Figure 1

### 1. INTRODUCTION

Extraction Tool 861751-1 shown in Figure 1 is designed to remove Type II and Type III+ pin and socket contacts from LGH commercial single-line connectors and LGH high-voltage circular connectors.



*Dimensions in this instruction sheet are in millimeters [with inches in brackets]. Figures are not drawn to scale.*

Reasons for reissue of this instruction sheet are provided in Section 6, REVISION SUMMARY.

### 2. DESCRIPTION

The extraction tool consists of a sleeve and handle to release the contact locking lance, and a push button to eject the contact from the connector.

### 3. USING THE TOOL

Make sure that the contact to be removed is compatible with this extraction tool. Then, refer to Figure 2, and proceed as follows (applies to both pin and socket contact):

1. From the mating face of the connector, align the sleeve of the extraction tool with the contact to be removed.
2. Holding the handle, insert the sleeve straight into the contact cavity until the sleeve bottoms. Allow the push rod button to "back out" of the handle as shown in Figure 2.
3. Rotate the handle in either direction to assure that the contact locking lance has released.

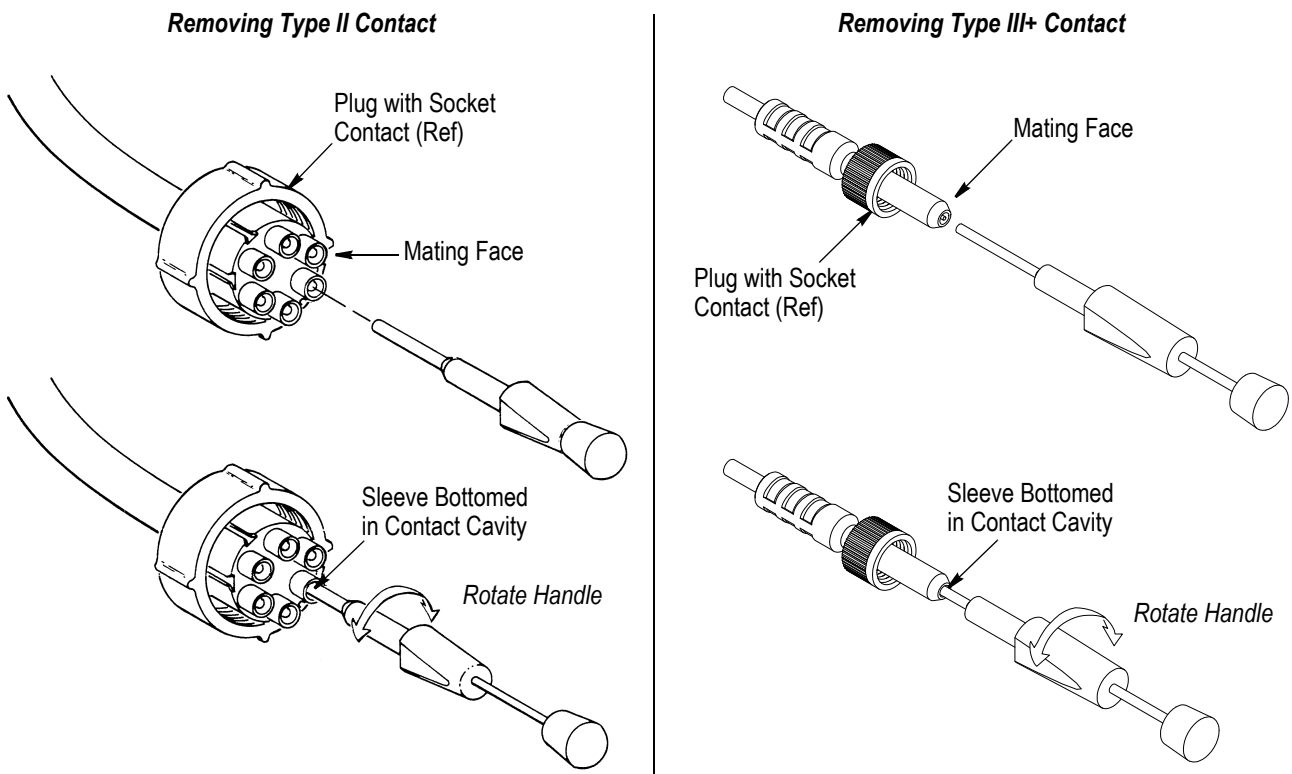

Figure 2

4. Keep the sleeve firmly bottomed in the contact cavity, and depress the push rod button. The contact will eject as the push button is depressed.

**4. INSPECTION**

The extraction tool is inspected prior to shipment and should conform to the dimensions provided in Figure 3. It is recommended that each tool be inspected upon arrival at your facility and at regularly scheduled intervals thereafter. To ensure that the tool retains its original dimensions, it should be stored in a clean, dry place and kept clean with a soft, lint-free cloth.

**5. REPLACEMENT AND REPAIR**

Order replacement tools through your representative, or call 1-800-526-5142, or send a facsimile of your purchase order to 717-986-7605, or write to:

CUSTOMER SERVICE (038-035)  
 TYCO ELECTRONICS CORPORATION  
 PO BOX 3608  
 HARRISBURG PA 17105-3608

**6. REVISION SUMMARY**

Revisions to this instruction sheet include:

- Updated instruction sheet to corporate requirements
- Added Type II contacts

*Extraction Tool Dimensions*

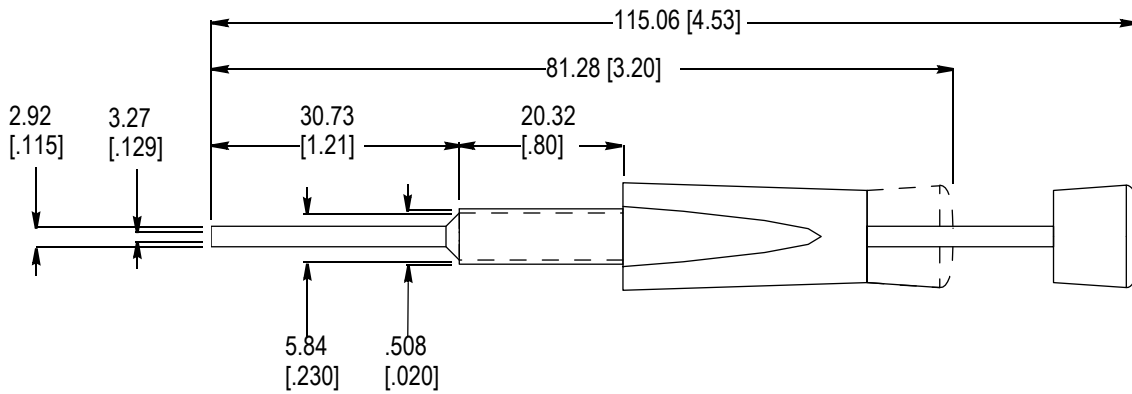

Figure 3