



Segmented Radial Crimp Machine (SRC-M)

Part number 2335600-[]

Customer Manual
409-35032
30 MAY 2024, Rev C

SAFETY PRECAUTIONS — AVOID INJURY — READ THIS FIRST!..... 4

Contents

1 Safety..... 6

- 1.1 Instruction 6
 - 1.1.1 Hydraulic 6
 - 1.1.2 Acoustic 6
 - 1.1.3 Heat 6
 - 1.1.4 Fire 6
- 1.2 Working area 7
- 1.3 Protective equipment..... 8
- 1.4 Emergency stop button..... 8
- 1.5 Warning labels..... 9

2 Machine description..... 10

- 2.1 Introduction 10
 - 2.1.1 Additional Documents 10
- 2.2 Specifications 10
- 2.3 Design and function..... 12
 - 2.3.1 Crimping tool 13
 - 2.3.2 Cable clamp assembly..... 14
 - 2.3.3 Terminal locator 15
- 2.4 Forming options 16
 - 2.4.1 Forming to a specified diameter 16
 - 2.4.2 Forming to a specified pressure 16
- 2.5 Operation and display elements 17
- 2.6 Operation modes 19

3 Receiving and installation..... 20

- 3.1 Transport 20
- 3.2 Storage 21
- 3.3 Installation..... 21
 - 3.3.1 Filling hydraulic fluid..... 22
 - 3.3.2 Bleeding the hydraulic system 23
 - 3.3.3 Electrical Connection 23
 - 3.3.4 Installing the terminal locator 24
- 3.4 Setting the Press Diameter..... 25

4 Activation and deactivation 26

- 4.1 Turning on the machine 26
- 4.2 Turning off the machine..... 26
- 4.3 Emergency stop..... 27

5	Crimping a terminal	28
6	Maintenance	34
6.1	Maintenance schedule.....	35
6.2	Changing the hydraulic fluid	36
6.3	Cleaning.....	37
6.4	Changing the crimping dies with the Quick Die Change (QDC) tool.....	37
6.5	Checking and replacing the slide bearing plates.....	40
6.6	Replacing the relay/opto-coupler.....	42
6.7	Calibration.....	43
6.8	CMK Function >Machine capability index	46
7	Troubleshooting	48
8	Error message	48
9	Decommissioning and disposal	49
9.1	Decommissioning	49
9.2	Disposal.....	49
10	Replacement and repair	50
11	Diagrams	50
11.1	Electric diagram.....	50
11.2	Hydraulic diagram	51
12	Forms	52
12.1	Maintenance log	52
12.2	Declaration of qualified staff.....	53
13	Revision summary	53

SAFETY PRECAUTIONS — AVOID INJURY — READ THIS FIRST!



NOTE

Keep all decals clean and legible. Replace them when necessary.



DANGER

ELECTRIC SHOCK HAZARD

This tool is not insulated. When using this unit near energized electrical lines, use proper personal protective equipment.



Failure to observe this warning could result in severe injury or death.



DANGER

Denotes an imminent hazard that can result in moderate or severe injury.



SKIN INJECTION HAZARD

Do not use hands to check for oil leaks. Highly pressurized oil punctures the skin, causing serious injury, gangrene, or death. If injured, seek immediate medical help to remove the oil.



DANGER

FIRE HAZARD

Do not use solvents or flammable liquids to clean the crimping tool. Solvents or flammable liquids could ignite and cause serious injury or property damage.



Failure to heed these warnings could result in severe injury from harmful fumes or burns from flying debris.



DANGER

Inspect the tool and dies before each use. Replace any worn or damaged parts. A damaged or improperly assembled tool can break and strike nearby personnel.

Failure to observe this warning could result in severe injury or death.



CAUTION

Do not place the tool in a vise. The crimping tool is designed for hand-held operation.

Protect the crimping tool from rain and moisture. Water damages the crimping tool and battery.

Failure to observe these precautions can result in injury or property damage.



CAUTION

Do not perform any service or maintenance other than as described in this manual. Injury or damage to the tool can result.

Failure to observe these precautions can result in injury or property damage.

Safeguards are designed into this application equipment to protect operators and maintenance personnel from most hazards during equipment operation. However, certain safety precautions must be taken by the operator and repair personnel to avoid personal injury, as well as damage to the equipment. For best results, application equipment must be operated in a dry, dust-free environment. Do not operate equipment in a gaseous or hazardous environment.

Carefully observe the following safety precautions before and during operation of the equipment:



Always wear approved eye protection while operating equipment.



Always turn off the main power switch and disconnect the electrical cord from the power source when performing repair or maintenance on the equipment.



Always wear appropriate ear protection while using equipment.



Never alter, modify, or misuse the equipment.



Moving parts can crush and cut. Always keep guards in place during normal operation.



Do not operate equipment if the guards are removed.



Electrical shock hazard.



Read and understand this entire document before using equipment.



Always turn off the main power switch and disconnect the electrical cord from the power source when performing repair or maintenance on the equipment.

SUPPORT CENTER

CALL TOLL FREE +1 800 522 6752 (CONTINENTAL UNITED STATES AND PUERTO RICO ONLY)

The **Support Center** offers a means of providing technical assistance when required. In addition, Field Service Specialists are available to provide assistance in the adjustment or repair of the application equipment when problems arise that your maintenance personnel cannot correct.

INFORMATION REQUIRED WHEN CONTACTING THE SUPPORT CENTER

When calling the Support Center regarding service to equipment a person familiar with the device should be present with a copy of the manual (and drawings) to receive instructions. Many difficulties can be avoided in this manner.

When calling the Support Center, be ready with the following information:

- Customer name
- Customer address
- Person to contact (name, title, telephone number, and extension)
- Person calling
- Equipment number (and serial number, if applicable)
- Product part number (and serial number, if applicable)
- Urgency of request
- Nature of problem
- Description of inoperative components
- Additional information that may be helpful

1 Safety

1.1 Instruction

1.1.1 Hydraulic

**CAUTION**

Relieve the residual pressure in the system before performing repair or maintenance work on hydraulic systems.

Hydraulic systems are subject to special safety provisions.

- Repair work on the hydraulic system of the machine or on its components must be performed **only** by TE Connectivity specialist staff.
- Regularly check lines and bolted connections for leaks and damage (see section 6.1).

1.1.2 Acoustic

The operation of the machine causes noise emissions of less than 70 dB(A) at the workplace. Hearing protection is not required.



Hydraulic fluid, lubricants, and emulsions can penetrate the skin. Use skin protection appropriate for the substances used. Comply with the manufacturer's safety instructions.

1.1.3 Heat



The electric motor and the terminal can be hot after crimping. Wear protective gloves and keep away from the motor.

1.1.4 Fire

**CAUTION**

Ensure that operators know the location of fire alarms and fire extinguishing equipment. Maintain free access to this equipment and train all personnel in its use.

**CAUTION**

Never use water to extinguish a fire. Refer to the safety data sheet of the hydraulic fluid supplier for information about appropriate extinguishing methods.

1.2 Working area

The working area is defined as a rectangle extending 1 meter away from the machine on all sides (Figure 1).

- Keep the working area free from tripping hazards.
- Use ducts for lines and cables.
- Provide good illumination.
- Maintain clear access to hydraulic supply.

Figure 1: Working area.

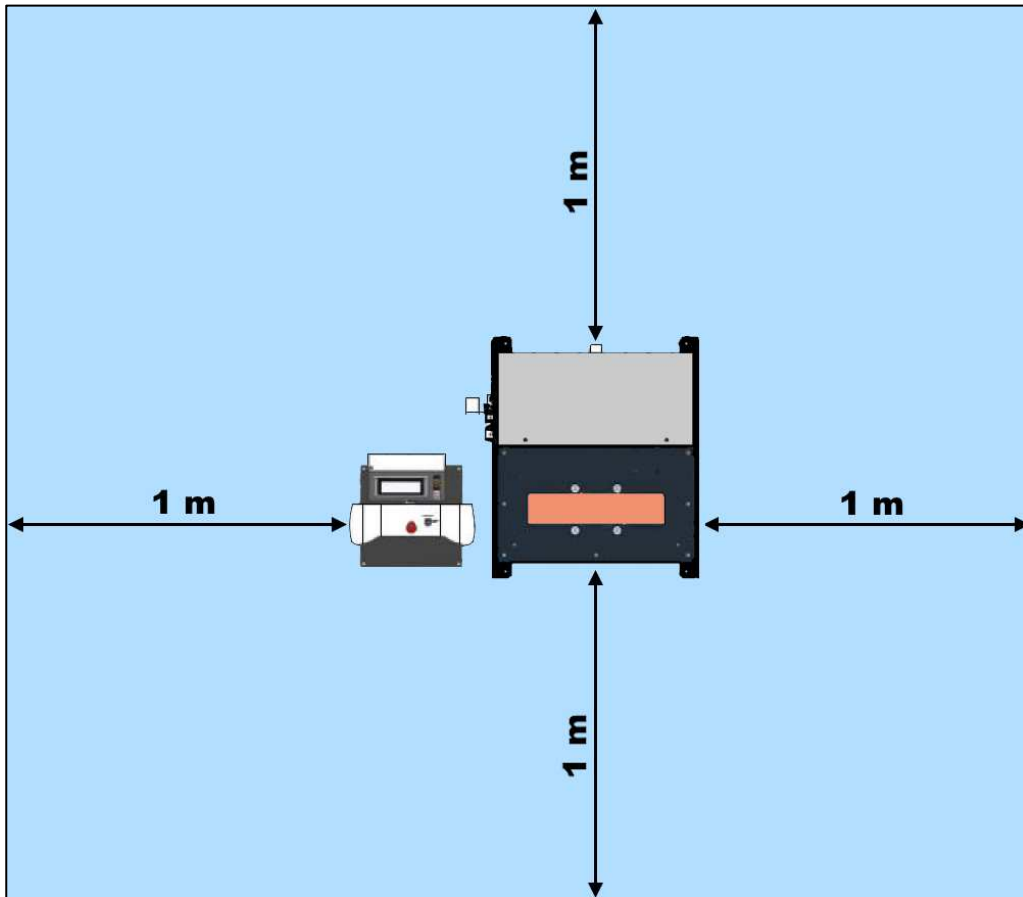

1.3 Protective equipment



DANGER

Do not operate the equipment without guards in place.

Due to the variety of customer-specific terminals, TE Connectivity cannot supply additional standard protection equipment for the prevention of potential residual risks imposed by the machine.

For example, additional protective equipment would be required for angled terminal geometries needing a large opening for insertion into the crimping machine. The pressure joining of insulators, structural steel, and steel cables can also require special safeguards.

You must determine what additional protective equipment and install it before commissioning the machine.

TE Connectivity can provide customized solutions for protective equipment on request.

1.4 Emergency stop button

The emergency stop button for the machine is located on the control panel (Figure 2).

1. In case of emergency, press the emergency stop button immediately.
2. Remedy the cause of the emergency stop.
3. Twist the emergency stop button counter-clockwise to unlock it.





Figure 2: Emergency stop button.



1.5 Warning labels

Several warning labels are affixed to the machine in the crimping die area (Table 1). Missing or illegible labels must be replaced immediately.

Table 1: Warning labels

Label	Meaning
	<p>Risk of hand injury. Keep hands clear of the dies.</p>
	<p>Moving parts can crush and cut. Keep hands clear of the dies.</p>
	<p>Hot surface on the electric motor.</p>
	<p>Do not lubricate the dies.</p>
	<p>Eye protection is required.</p>

2 Machine description

2.1 Introduction

The Segmented Radial Crimp Machine (SRC-M) provide Hydraulic Press for large wire size products.

2.1.1 Additional Documents

1. [114-97858](#) - Segmented Radial Crimp (SRC) Closed Barrel Core Crimp termination – General Guideline.
2. 114-xxxxx - Product Associated Application Specification (given on Customer Drawing of Product).
3. [2439743](#) - Customer Drawing - TE Measure Tips.
4. [408-35335](#) - Instruction Sheet CQM.

2.2 Specifications

Table 2: Machine specifications.

Length	645 mm
Width	560 mm
Height	1450 mm
Control system	CONTROL C.2 / IPC
Operation mode	S6-70%
Noise level	< 70 dB(A)*
Degree of protection	IP 40
Forming force	1320 kN [135 tons]
Maximum crimping range	Ø dies + 12 mm (maximum outer diameter of the fittings before crimping)
Maximum Ø dies	70 mm
Opening size without dies	105 mm
Opening distance	+35 mm
Velocity (closing)	10 mm per second*
Velocity (forming)	5 mm per second*
Velocity (opening)	10 mm per second*

*Value is theoretical, computed, or measured on a prototype. Actual value can vary slightly, depending on the machine.

Table 3: Electrical.

Connection power	5.5 kW
Adjustable connection voltage (3 phases + PE)	230V 50/60 Hz 380V 50/60 Hz 400V 50/60 Hz 420V 50 Hz 440V 60 Hz 460V 60 Hz 480V 60 Hz
Voltage selection by plug position (3 phases)	Δ 230V 50/60 Hz Y 380-480V 50/60 Hz
Motor protection setting (red marks at adjustment scale)	230V, 21A 380-480V, 13A
Backup fuse (preferably thermal fuses or class C circuit breakers)	230V, 20A delayed 400V, 16A delayed

Table 4: Hydraulic.

Fluid capacity	80 liters [21.1 gallons]
Fluid type	HLP 46, DIN 51524, 10μ filtered
System pressure	280 bar maximum

Table 5: Environmental requirements.

Permanent floor loading	0.07 kg/mm ² (approximate)
Floor carrying capacity	2500 kg/m ² minimum
Floor quality	B25
Unevenness	5 mm/m maximum
Inclination	5 mm/m maximum
Ambient temperature	10-35° C
Humidity	45-65%

2.3 Design and function

The crimping tool (Figure 3) is closed hydraulically. The pressure to crimp the terminal is built up by the electrically driven pump in the cylinders.

The position encoder system (Figure 4) records the current position of the dies and transfers the value to the control system.

Data records can be saved in the item memory and recalled at any time in the control system. Depending on the operation mode, the actual crimping process is controlled via the buttons on the control panel.

Figure 3: Components (exterior).



- 1** Two-hand control panel
- 2** Crimping tool
- 3** Control cabinet
- 4** CQM Kit (optional)

Figure 4: Components (interior).

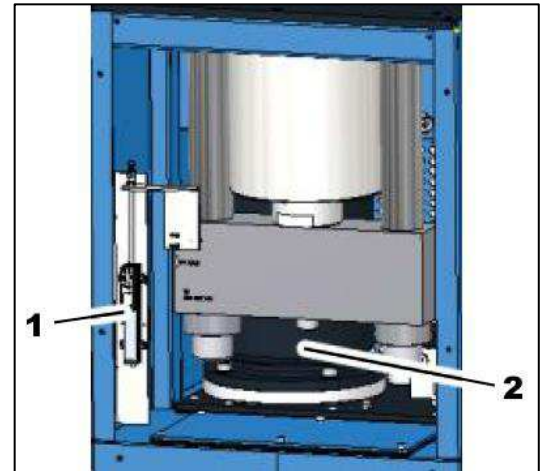

- 1** Position encoder system
- 2** Unit (electric motor, pump, and control block)

2.3.1 Crimping tool

The die system includes basic dies and crimping dies (Figure 5). All basic dies are supported on sliding plates. The crimping dies are plugged onto the basic dies.

When the tool opens after the crimping process, the springs separate the basic dies. The holding plates guide the basic dies axially in the tool.

Figure 5: Crimping tool.

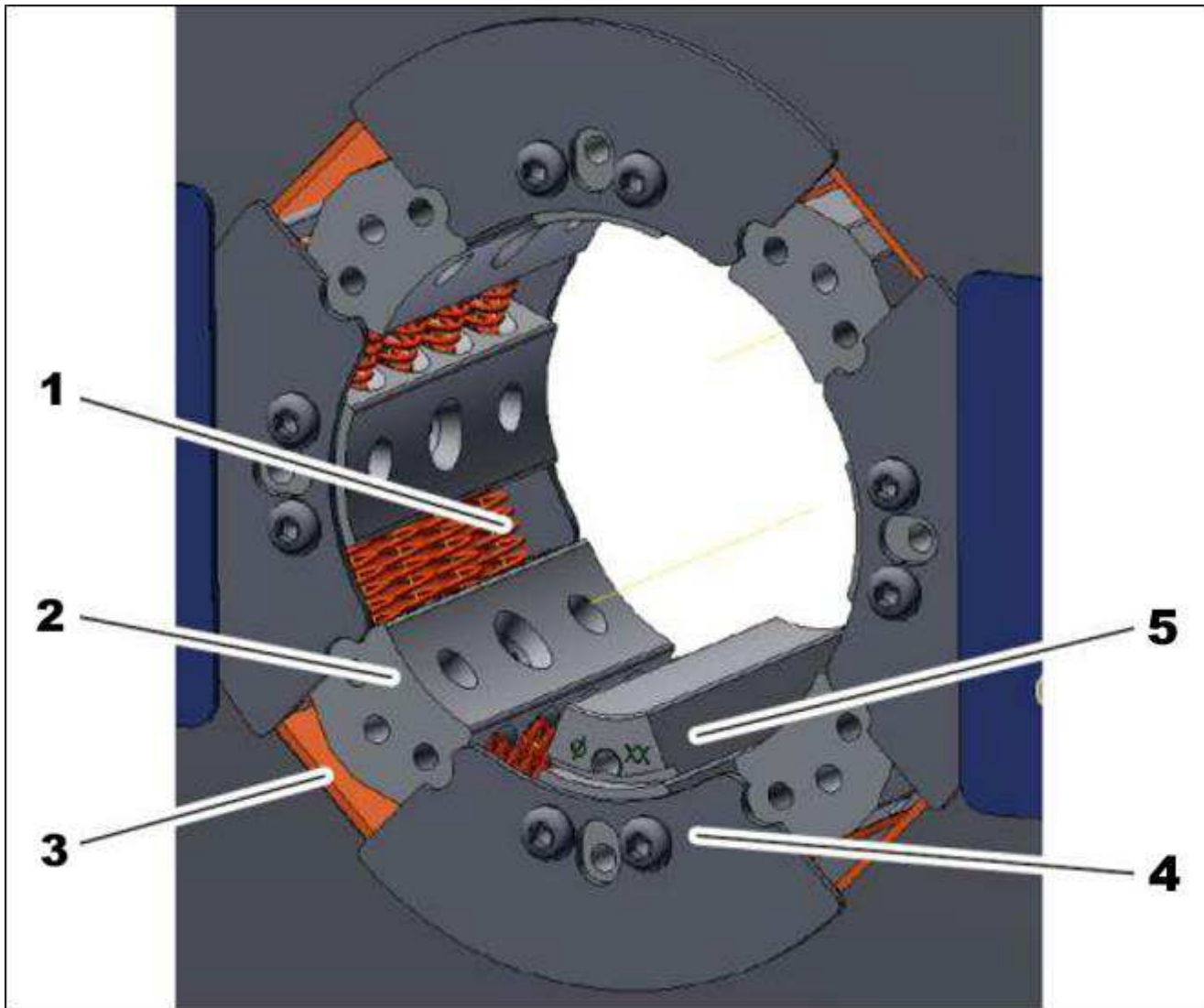

- 1** Springs
- 2** Basic dies
- 3** Sliding plates
- 4** Holding plates
- 5** Crimping dies

2.3.2 Cable clamp assembly

The cable clamp assembly (Figure 6) holds the cable in place during the crimping process.

Figure 6: Cable clamp.

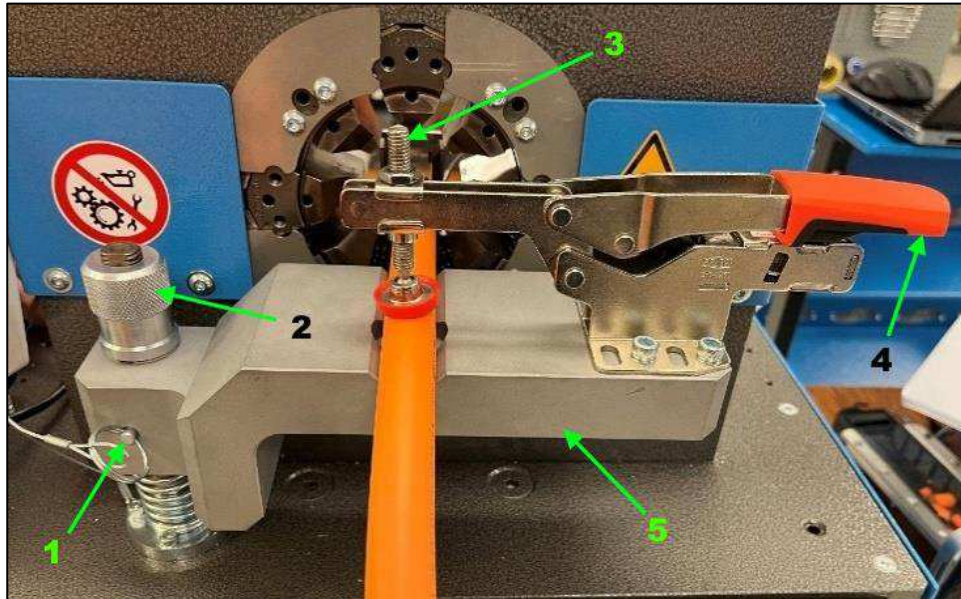

- 1 Locking pin
- 2 Height adjustment knob
- 3 Cable diameter adjustment screw
- 4 Handle
- 5 Swing arm

- The height adjustment knob raises or lowers the cable clamp assembly so that the cable is correctly aligned with the terminal.
- The cable diameter adjustment screw is used to adjust the clamp so that it fits the cable.
- Removing the locking pin allows the cable clamp assembly to rotate away from the crimp tool, providing unobstructed access when you need to change the die set.

2.3.3 Terminal locator

The terminal locator (Figure 7) holds the terminal in the correct position during the crimping process. Each terminal type requires a different terminal locator.

Figure 7: Terminal locator.

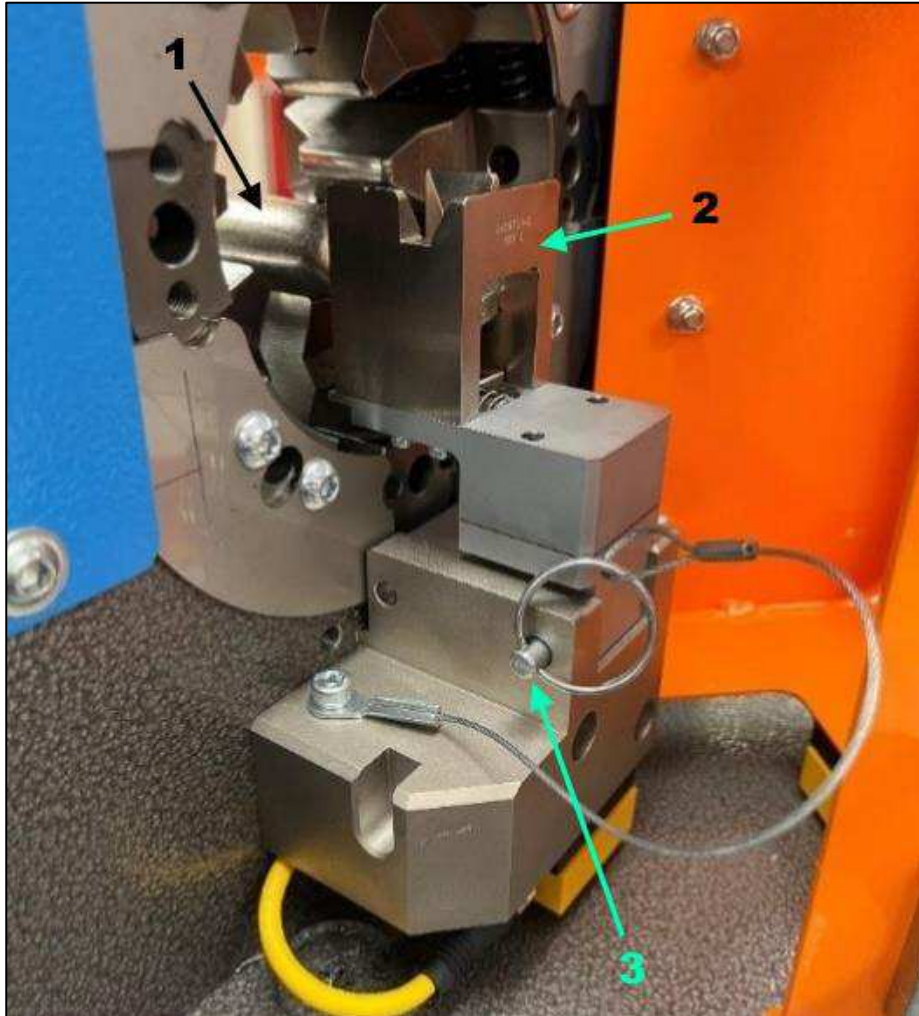

- 1** Terminal
- 2** Terminal locator
- 3** Locking pin

2.4 Forming options

The machine equipped with a Crimp Quality Monitor (CQM) as alternate (preferred) option provides two forming options with different target parameters:

- Forming to a specified diameter
- Forming to a specified pressure

2.4.1 Forming to a specified diameter

This is the standard process for crimping if the Product Associated Application Specification points out a specified diameter. The crimping tool closes until it reaches a pre-set diameter, regardless of the required forming force. The required forming force can be up to the machine's maximum capacity.

Optionally, you can monitor the required forming pressure (forming force) at the time when the pre-set diameter is reached. This enables you to detect terminal deviations (PFM option: Pressure Force Monitoring).

2.4.2 Forming to a specified pressure

This process is used only if explicit requested in the Product Associated Application Specification. Due to the terminal tolerances, forming to a specific diameter can destroy the terminal. The crimping tool closes until the pre-set pressure value is reached. No diameter control is used.

Optionally, you can monitor the required forming diameter at the time when the pre-set pressure is reached. This enables you to detect terminal deviations (PFM option: Pressure Force Monitoring).

DANGER



Ensure that the terminal, cable, die set, and Press Diameter are all correct. Over crimping or using the wrong die set can cause a sudden failure. If this happens, flying chips or terminal parts can injure people and damage equipment, even outside the working area.

CAUTION



When using the machine in series production, do not permanently load it with more than 2/3 of the maximum operating pressure. A high permanent load increases wear disproportionately, reducing the lifetime of the machine.

2.5 Operation and display elements

Figure 8 shows the controls on the front of the control panel.

Figure 8: Operation and display elements.

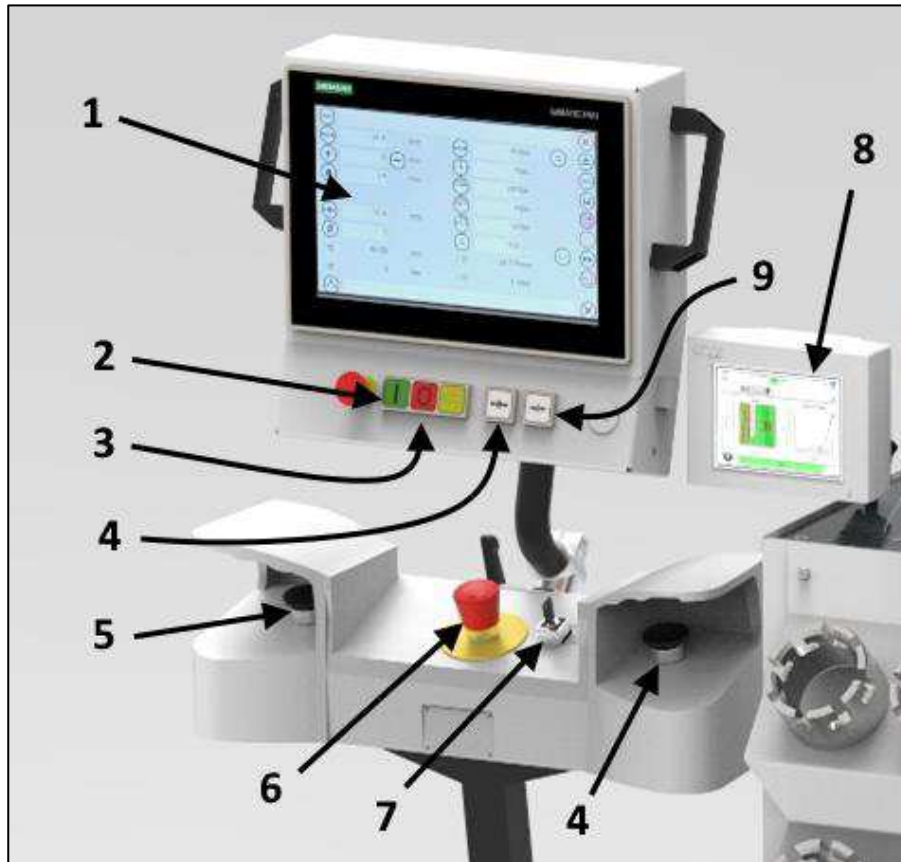

- | | |
|---|-------------------------|
| 1 Control panel | 6 Emergency stop button |
| 2 Motor on button | 7 Key switch |
| 3 Motor off button | 8 CQM host module |
| 4 Open tool button | 9 Close tool button |
| 5 Palm buttons for two-handed operation | |



NOTE

The positions of the motor on and off buttons might be reversed, depending on the control version.

- The key switch determines which buttons are enabled for crimping operations (see section 5 on page 28).

- Figure 9 shows the ports on the back of the control panel.

Figure 9: Ports.

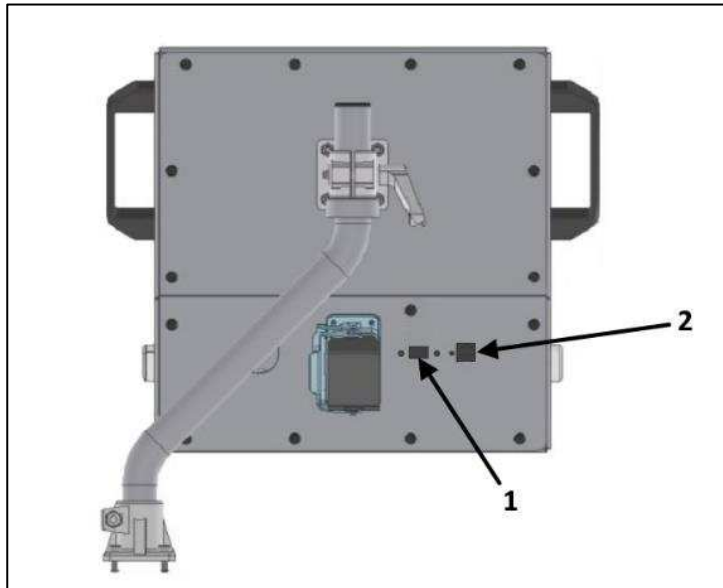

- 1** USB port
- 2** Network port

- The USB ports are for memory media, calipers, or bar code scanners certified by TE Connectivity.
- The network port is for connection to a local area network.
- Figure 10 shows the electrical sockets on the side of the machine.

Figure 10: Electrical sockets.

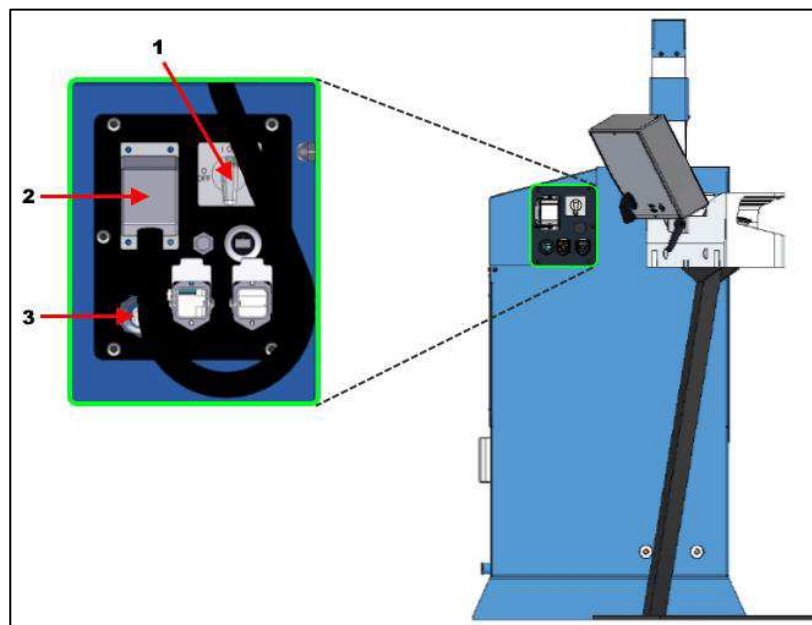

- 1** Main power switch
- 2** Control panel connection
- 3** Power cable screw connection

2.6 Operation modes

The control unit provides two operation modes for operating the crimping tool. Select the mode you want by pressing the corresponding button on the control panel. (The appearance of the mode buttons varies depending on the control version, as shown in Table 6.) Production is possible in either operation mode.

Manual operation: Press the **Manual** button (Table 6) to select this mode. The crimping process is controlled manually with the buttons on the control panel (Figure 11).

- Press the **Close** button to close and crimp.
- Press the **Open** button to open.

When the pre-set crimping diameter or crimping pressure is reached in the control, the tool stops and opens automatically.

Semi-automatic operation: Press the **Semi-automatic** button (Table 6) to select this mode. The crimping process is controlled manually with the buttons on the control panel.

Press the **Close** button (Figure 11) to close and crimp. When the pre-set crimping diameter or crimping pressure is reached in the control, the tool stops and opens automatically after the preset holding time.

Table 6: Mode buttons.

Mode	C.2	IPC
Manual		
Semi-automatic		

Figure 11: Open and close buttons.

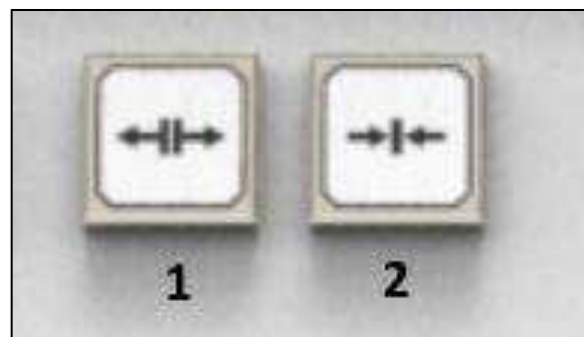

- 1 Open
- 2 Close



NOTE

When the machine is deactivated, it remembers the operation mode you were using and automatically selects it after the next restart.



CAUTION

Due to safety, use Two-hand operation (see section 5.1) as primary operation method.

3 Receiving and installation

3.1 Transport

The machine must be transported only in the original packaging. During transport, the machine must be secured safely within the packaging. Comply with all applicable laws and regulations relating to securing loads.

The machine must be unloaded and moved only with a forklift, a lift truck, or a crane. If a crane is used, lifting gear with sufficient length and lifting capacity is required. For machine weight, see Table 2 on page 10.

Lift the machine at the designated points (Figure 12) and transfer it to the location of installation.

DANGER
 To avoid injury, **do not** stand or walk under suspended loads.

DANGER
 The machine can tilt and fall if it is transported improperly. To avoid injury and equipment damage, consider the machine's center of gravity (Figure 12) and lift it **only** at the designated points.

Figure 12: Center of gravity and lift points.

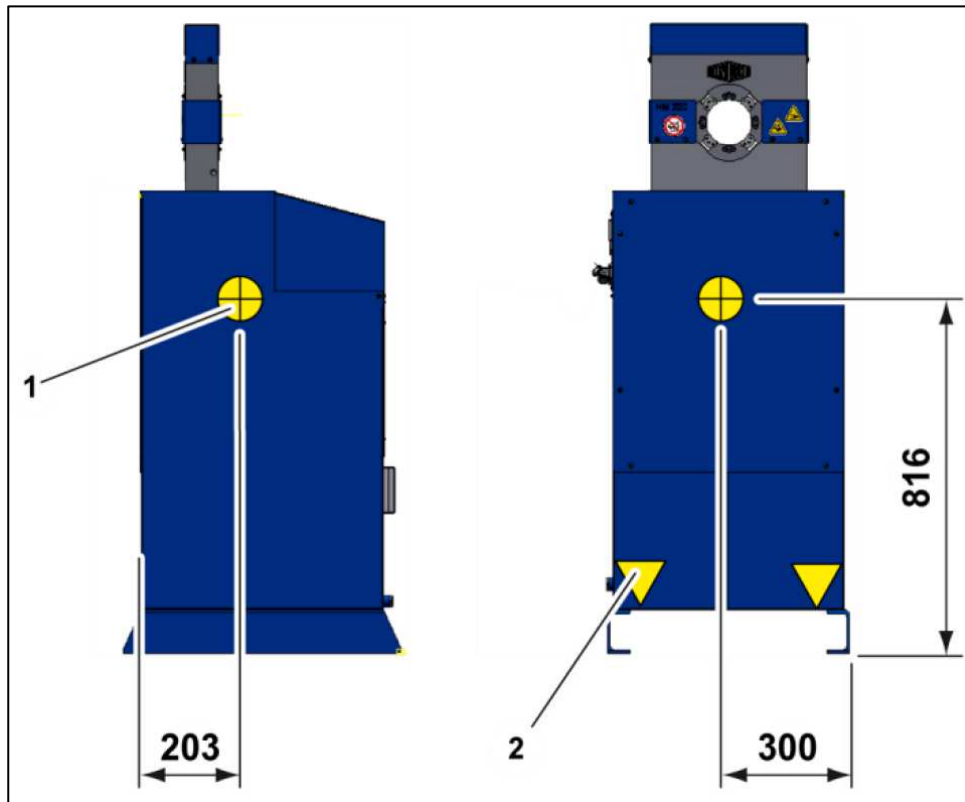

- 1 Center of gravity
- 2 Lift points

3.2 Storage

If the machine cannot be installed immediately upon delivery, it must be protected against contamination, weather influences, and mechanical damage. The machine components must be stored in closed rooms under the conditions listed in Table 7.

Table 7: Environmental requirements for storage.

Temperature	10-45° C
Maximum humidity	80% non-condensing

3.3 Installation

To install the machine, complete the following steps.

1. Place the machine on a flat surface at the place of installation.
2. Position the machine so that it is easily accessible from all sides for maintenance work.
3. Use suitable bolts to secure the machine legs to the floor.



DANGER

If the machine is not bolted to the floor, it can tilt and fall, causing injury and equipment damage.

4. Open and close the machine several times with no terminal or dies to check for loose parts or atypical noise.



DANGER

Machine components can loosen during transport. These components can be flung out during the crimping process, causing injury or equipment damage.

5. Check the electric cables for damage.
6. Train the operating staff. Record the training sessions in section 12.2.

3.3.1 Filling hydraulic fluid

If the machine was purchased without hydraulic fluid filling, the appropriate new, clean, and pre-filtered hydraulic fluid must be filled before commissioning.

DANGER



Hydraulic fluid can injure the skin, eyes, respiratory system, and intestinal tract. Wear protective equipment. Refer to the supplier's data sheet for protection and safety instructions. Ensure good ventilation and do not eat, drink, or smoke in the working area.



CAUTION

Spilled hydraulic fluid creates a slipping and falling hazard. Clean up any spills immediately.



CAUTION

Hydraulic fluid is flammable. Fluid spray or spills create a fire hazard. Keep ignition sources (such as welding, cutting, or soldering work) away from the machine during hydraulic fluid filling. Do not smoke in the working area.

To fill the hydraulic fluid, complete the following steps:

1. Remove the grating (Figure 13).
2. Open the fill cap.
3. Begin adding hydraulic fluid. (For quantity and type, refer to Table 4 on page 11.)
4. Continue adding fluid until the level reaches the center of the fill level indicator.
5. Close the fill cap.
6. Reinstall the grating.
7. Wait at least four hours to allow dirt particles in the system to settle.

Figure 13: Filling hydraulic fluid.

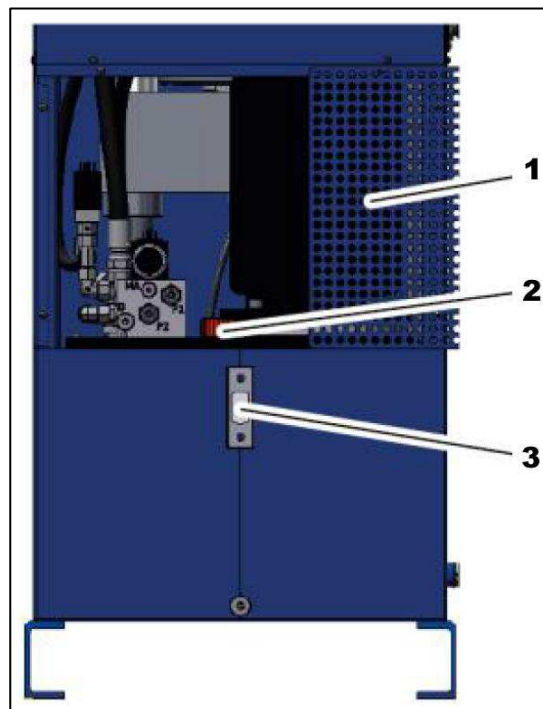

- 1 Grating
- 2 Fill cap
- 3 Fill level indicator

8. Check the electric motor rotational direction through the inspection window. Verify that the direction matches the red arrow on the motor cover. Reverse the outer cable (phases) of the connection, if necessary.



CAUTION

Extended operation of the motor with an incorrect rotational direction will destroy the hydraulic pump.

9. Verify that the hydraulic fluid level is sufficient before starting the machine.



CAUTION

Operating the machine without hydraulic fluid will destroy the hydraulic pump.

3.3.2 Bleeding the hydraulic system

1. Switch on the machine (see section 4.1).
2. Operate the machine in the idle mode for two minutes in order to fill the pump with hydraulic fluid.
3. Open and close the tool several times.
4. Check fluid level. Add hydraulic fluid if needed.

3.3.3 Electrical Connection



WARNING

There is a risk of electrocution near the live parts!

- *Work on electric systems may only be performed by qualified electricians or instructed and trained persons under the supervision of a qualified electrician.*
- *Do not operate the machine without a sufficiently rated ground wire.*
- *Deactivate the machine and secure it against unintentional restart before maintenance.*

Figure 14: Electrical Connection.

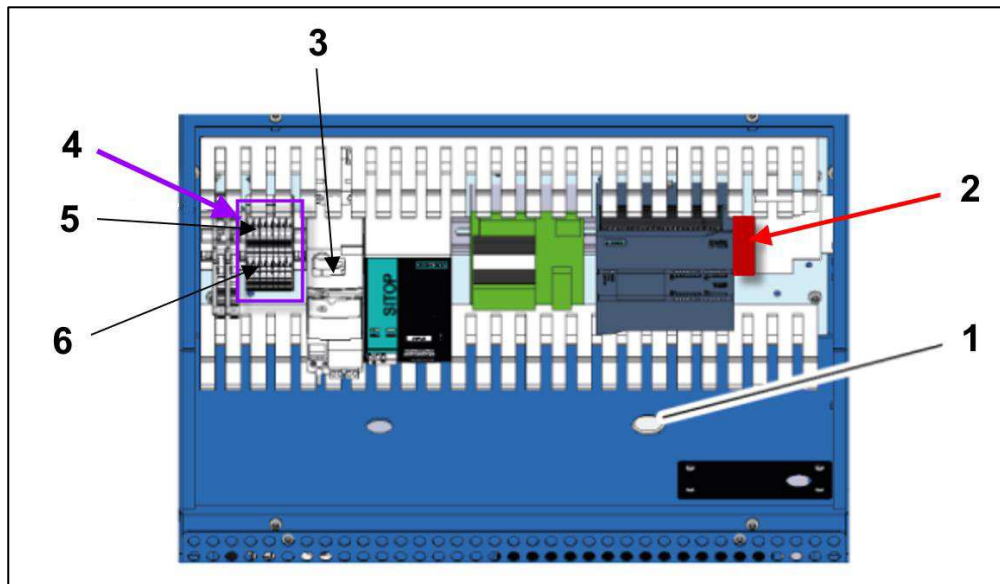

- | | |
|----------------------------------|---------------------------------|
| 1 Inspection window | 4 Voltage selection plug |
| 2 X100 Terminal Block | 5 Y connection |
| 3 Motor protection switch | 6 Δ connection |

1. Connect the voltage selection plug to the correct slot in the control cabinet - Δ 230V on connection (6), Y 380-480V on connection (5) (Figure 14).
2. Set the motor protection switch as specified in Table 3 under Motor Protection Setting (see section 2.2).



The permissible voltage frequency ranges and the relevant motor protection setting are also indicated on the sticker in the control cabinet.

3. Have the power cable of the machine connected to the local mains by a qualified electrician according to the regulations of the Electricity Board.
4. Dismantle the control cabinet cover and check the electric motor rotational direction according to the arrow through the inspection window. Exchange outer cable (phases) of the connection, if required to change rotation.



CAUTION

Extended operation of the motor with an incorrect rotational direction or operating the machine without oil will destroy the hydraulic pump.

- *Make sure that the hydraulic oil filling in the machine is sufficient before starting the machine.*
- *Ensure that the rotational direction of the motor is correct. Observe the red arrow on the motor cover.*

3.3.4 Installing the terminal locator

To install the terminal locator, complete the following steps:

1. Open the rear cover of the tool.
2. Remove the locking pin (Figure 15).

Figure 15: Locking pin.

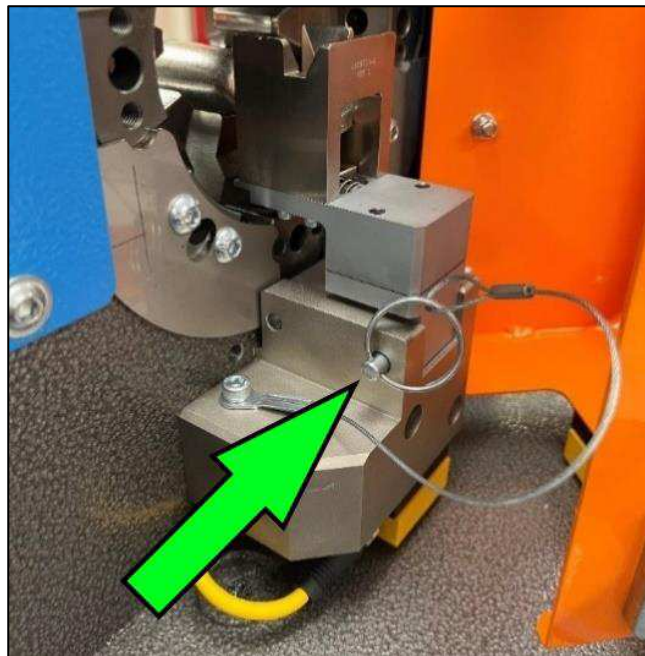

3. Slide the terminal locator into position.
4. Reinstall the locking pin.
5. Close the rear cover.

3.4 Setting the Press Diameter

The Press Diameter (Figure 16) must be set specifically for the terminal.

1. Read the Press Diameter in the Press Diameter table of the terminal supplier (for example, \varnothing 17.4 mm).
2. Select crimping dies with a diameter equal to or less than the Press Diameter. For example, if the supplier's table lists a Press Diameter of \varnothing 17.4 mm, you could select crimping dies with a diameter of \varnothing 17 mm.
3. Place the crimping dies in the tool.
4. Set the control system or micrometer to the required dimension:

Control system: Crimping die diameter.

Micrometer: Terminal Press Diameter minus crimping die diameter.

5. Make a test crimp.
6. Check the terminal for the correct Press Diameter.
 - If the Press Diameter is correct, crimp other identical terminals.
 - If the Press Diameter is **not** correct, adjust the control or micrometer settings. Repeat steps 5 and 6.

Figure 16: Press Diameter.

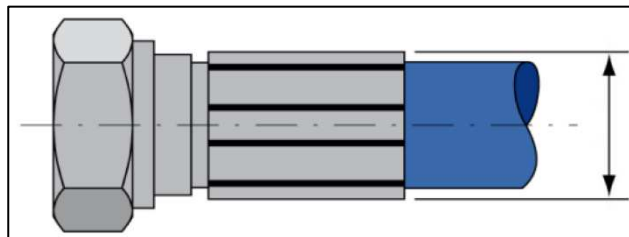

4 Activation and deactivation

4.1 Turning on the machine

1. Check the screen to verify that no emergency stop notification is displayed.
2. Turn on the power switch (Figure 17). After a few seconds, the starting screen is displayed.

Figure 17: Power switch on.

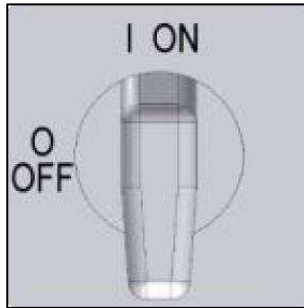

4.2 Turning off the machine

1. Complete the crimping process.
2. Deposit the work piece outside the machine.
3. Turn off the main switch (Figure 18).

Figure 18: Power switch off.

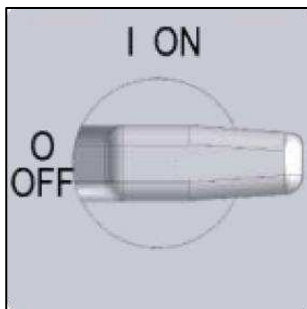

4. Check the machine for contamination, leaks, and external damage.
5. Check the crimping tool and retaining bolts for contamination, damage, and secure fitting.
6. Check the hydraulic fluid level.
7. Use a vacuum cleaner to remove contamination, dust, and chips.

4.3 Emergency stop

In case of emergency, press the emergency-stop button (Figure 19). The crimping tool movement stops. The drive unit shuts down.

Figure 19: Emergency stop button.



DANGER

The emergency-stop button was probably pressed because of a hazardous situation. **Do not** restart the machine until the hazard has been eliminated.

1. Remedy the cause of the emergency stop.
2. Touch the **OK** button on the screen. The error messages are cleared.
3. Twist the emergency-stop button counter-clockwise to unlock it.

5 Crimping a terminal



Always wear approved eye protection while operating equipment.



DANGER

Moving parts can crush and cut. Keep hands clear to avoid injury.



DANGER

Do not wear jewelry, loose clothing, or long hair that can catch in moving parts of the equipment.

When the tool closes, any object that gets too close can be crushed between the dies and the terminal.

- Keep the feed opening for the terminal as small as possible. Excessive opening creates a risk of injury and lost time.
- Keep your hands at least 120 mm away from the dies (Figure 20).

Figure 20: Minimum distance 120 mm.

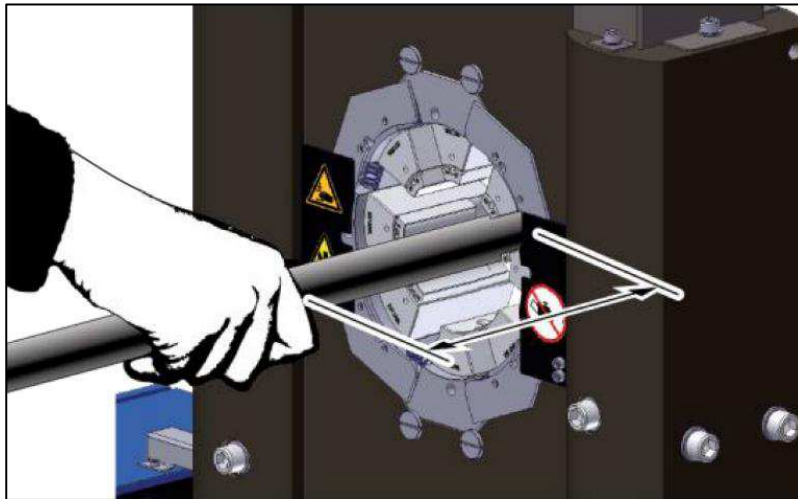

During operation, observe the following precautions:

- Comply with the safety instructions on the machine.
- Make sure that no other persons stay in the working area.
- Eating, drinking, and smoking at the workplace is prohibited.

Before crimping, verify that:

- The work area is properly illuminated.
- The cable from the control panel is plugged into the control cabinet (see Figure 10 on page 18).
- The control cabinet is closed securely.
- The dies are correctly mounted in the tool.
- The Press Diameter and the dies have been entered into the control system as described in section 3.4.
- The die set and terminal locator are appropriate for the terminal you are crimping.

**CAUTION**

Using the wrong components can damage the tool or the terminal.

**NOTE**

Use the **Form To Diameter** option. Do not use the **Form to Pressure** option. See section 2.4 for details.

**DANGER**

When the tool closes, anything between the die and the terminal can be crushed, causing serious injury or equipment damage.

**DANGER**

Stay at least 120 mm away from the dies while the machine is in operation.



Always wear approved eye protection while operating equipment.

1. Turn the key switch to select the operation method you want to use (Figure 21).

Figure 21: Key switch positions.

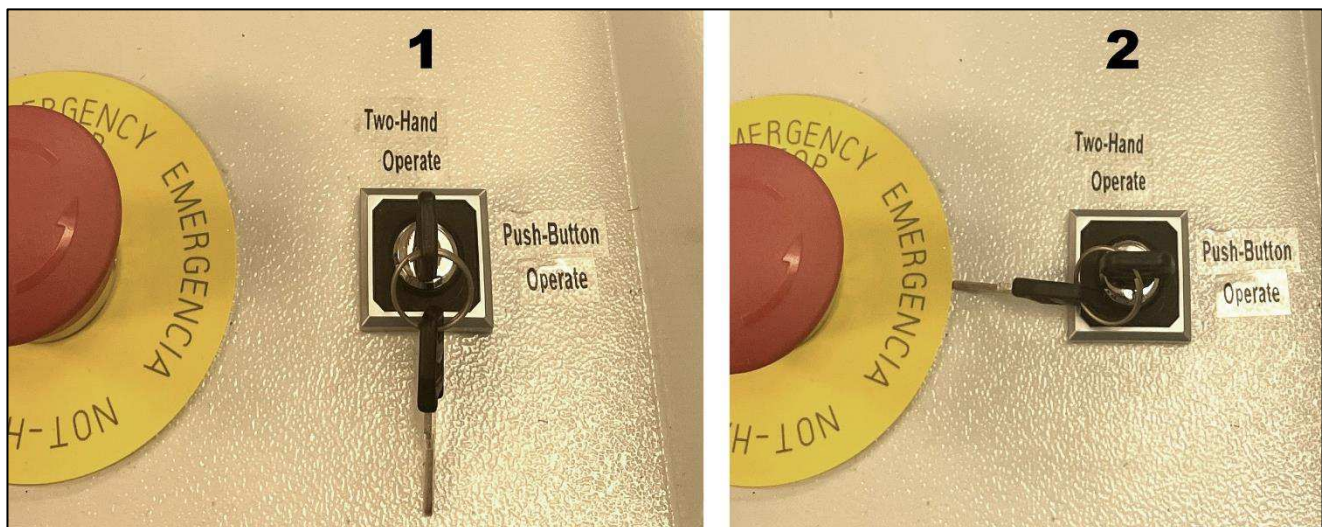

- 1 Two-handed operation
- 2 Push-button operation

The operation buttons on the control panel (Figure 22) are enabled or disabled as shown in Table 8.

Table 8: Effect of key switch position.

Button	Push-button operation	Two-handed operation
Open Tool	✓	✓
Close Tool	✓	
Palm (both)		✓

Figure 22: Operation buttons.

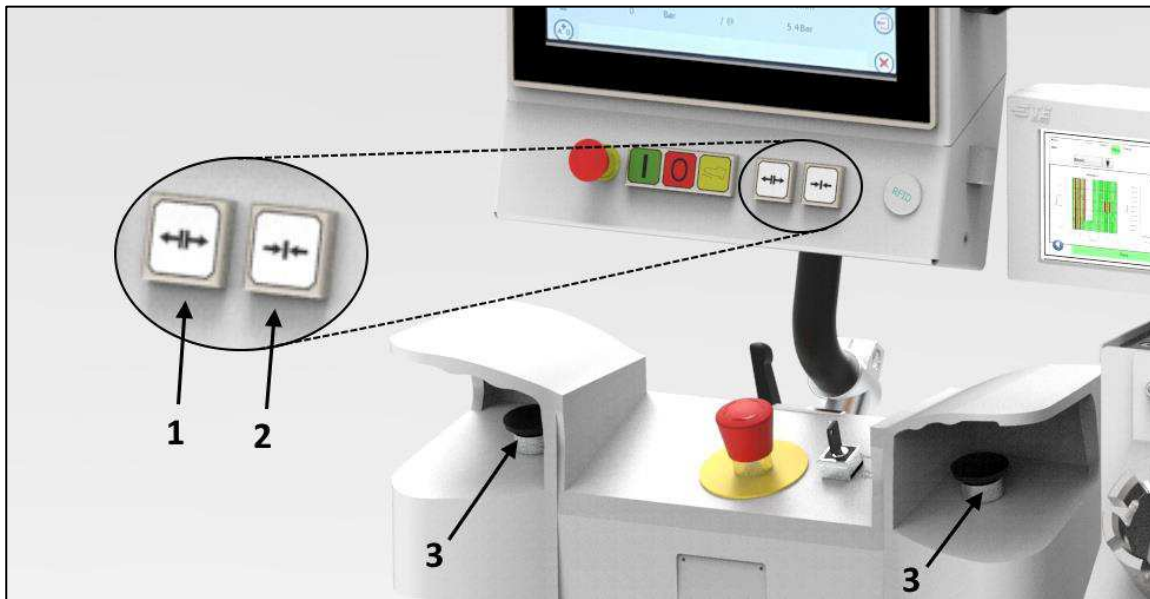

- 1 Open button
- 2 Close button
- 3 Palm buttons

2. Open the rear cover of the tool (Figure 23). Install terminal locator (see section 3.3.4).

Figure 23: Rear cover opened.

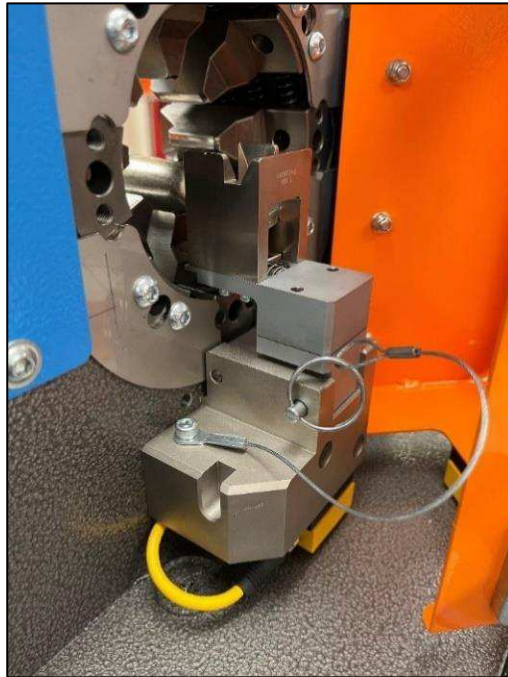

3. Close the rear cover.
4. Open the cable clamp by lifting the handle (Figure 24).

Figure 24: Opening the cable clamp.

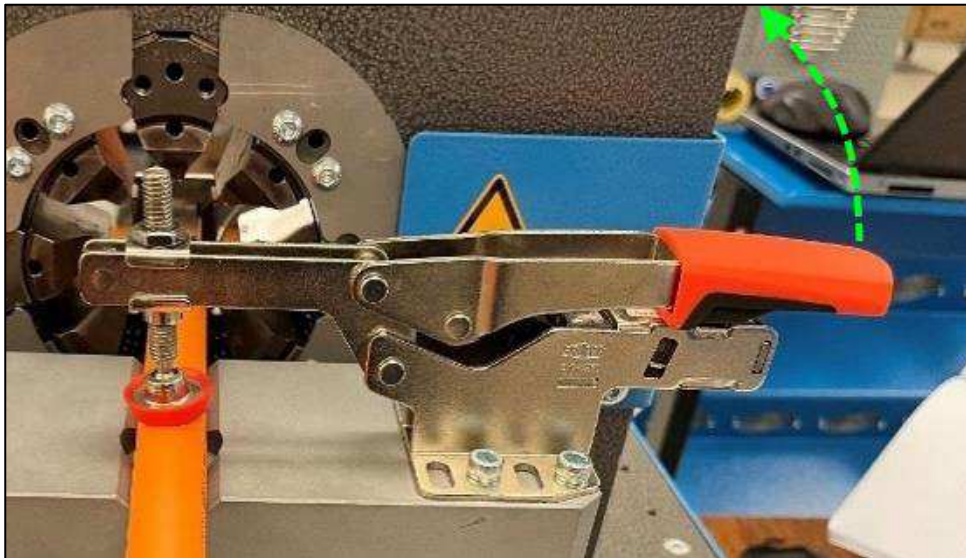

5. Insert the pre-mounted terminal into the terminal locator (Figure 25).



NOTE

For best results, position the terminal in the center of the crimping die length. Off-center crimping leads to a conical crimping result and causes the dies and the bearing plates to wear asymmetrically.

Figure 25: Inserting the terminal.

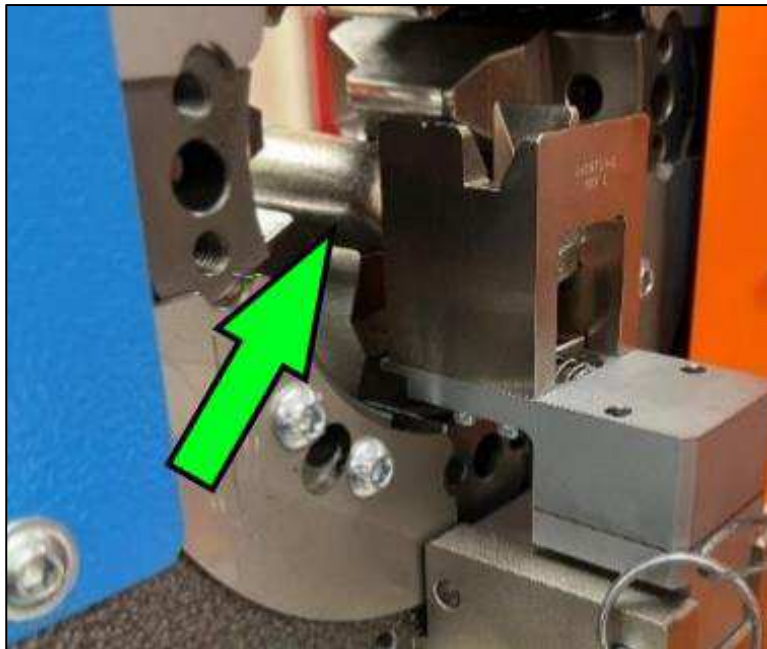

6. Close the cable clamp to lock the cable in place.
7. Enter the crimp settings on the Control Panel screen (Figure 26). The values of these settings are determined as described in Table 9.

Figure 26: Entering crimp settings.

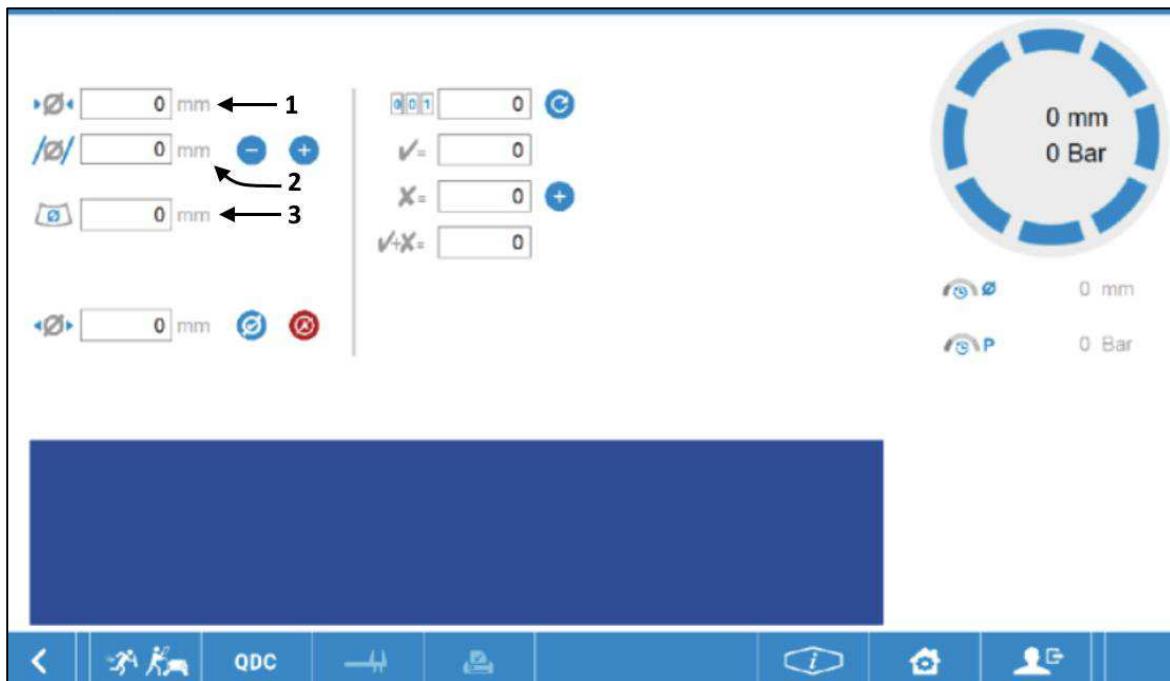

- 1 Crimp diameter
- 2 Crimp adjustment
- 3 Die diameter

Table 9: Crimp settings.

Setting	Value
Crimp diameter	Specified by terminal supplier
Crimp adjustment	Increase or decrease crimp in 0.1 mm increments for fine adjustment
Die diameter	Nominal diameter marked on dies

8. Activate the crimping process (Table 10). Crimping starts. It ends when the pre-set diameter or pressure are achieved.

Table 10: Activating the crimping process.

Operation method	How to activate
Two-hand	Press and hold both palm buttons simultaneously

i **NOTE**

“Simultaneously” means that the palm buttons must be pressed within 0.5 seconds of each other. If the delay between button presses is longer than half a second, the machine does not activate.

9. *Two-hand operation only:* After the crimping process is complete, release the palm buttons.
10. Open the tool (Table 11).

Table 11: Opening the tool.

Operation mode	How to activate
Manual	Press the Open button.
Semi-automatic	Wait. After the specified hold time expires, the tool opens automatically.

11. Raise the handle to open the cable clamp.
12. Remove the crimped terminal from the tool.
13. Check the Press Diameter after the first crimping process. If it does not match the height specified by the system supplier, correct it (see section 3.4).

6 Maintenance

Regular maintenance ensures the continuous operation and reliability of the device. This section describes how to ensure the trouble-free use of the machine.

- Maintenance work must be performed only by qualified maintenance staff.
- Repair work on the machine or components must be performed only by appropriately qualified expert staff or TE Connectivity experts.



Lock out electrical power when performing maintenance or repair on this equipment.

- The machine must always be deactivated during maintenance work (see section 4.2). Use a lock to prevent the main switch from being switched on. Attach a sign like the one shown in Figure 27.

Figure 27: Out of service sign.

**Machine out of service
for maintenance work.
DO NOT turn on.**

- Welding, flame-cutting, and grinding work on and in the machine and its environment must be approved in advance.



CAUTION

Remove fire hazards. Clean dust and flammable substances from the machine. Ensure adequate ventilation.

6.1 Maintenance schedule

Inspections are visual unless otherwise specified. Replace defective parts.

NOTE

If you work in two or three shifts, double the check frequency.

Record maintenance work performed in the maintenance log (section 12.1). This includes hydraulic fluid changes and replacement of worn parts.

Table 12: Hydraulic system maintenance.

Item	Maintenance task	Frequency
Hydraulic energy lines (hoses)	Check for porosity and leaks.	Monthly
Hydraulic energy lines (bolted connections of hoses and pipes)	Check for leaks.	
Hydraulic fluid	Check level. Add fluid as needed.	See section 6.2
Hydraulic fluid filter	Replace.	When indicated by control display
Hydraulic fluid	Replace.	Annually
Hydraulic hoses	Replace with high-pressure DIN 20066 hoses of equivalent quality.	Every six years

Table 13: Crimping tool maintenance.

Item	Maintenance task	Frequency
Crimping tool	Check for wear and damage	Monthly
Retaining bolt	Check for damage	
Slide bearing plates	Check for damage (section 6.5)	Every 6 months
Pressure springs between base dies	Check for damage	
Guiding plates	Check for wear	
Hex socket screws in base dies	Re-tighten (M5, torque MA = 8 Nm)	Annually
Bolted connections	Check for secure fit; re-tighten as needed	
Crimping tool	Complete overhaul	After 150,000 crimping cycles

Table 14: Safety equipment maintenance.

Item	Maintenance task	Frequency
Emergency stop button	Check function	Weekly
Permanently installed partitioning protection equipment and covers	Check for completeness and correct installation	Monthly
Warning labels	Check legibility (see section 1.5)	Every 6 months

6.2 Changing the hydraulic fluid

DANGER
 Hydraulic fluid can injure the skin, eyes, respiratory system, and intestinal tract. Wear protective equipment. Refer to the supplier's data sheet for protection and safety instructions. Ensure good ventilation and do not eat, drink, or smoke in the working area.

CAUTION
 Spilled hydraulic fluid creates a slipping and falling hazard. Clean up any spills immediately.

CAUTION
 Hydraulic fluid is flammable. Fluid spray or spills create a fire hazard. Keep ignition sources (such as welding, cutting, or soldering work) away from the machine during hydraulic fluid filling. Do not smoke in the working area.

 Lock out electrical power when performing maintenance or repair on this equipment.

1. Shut down the machine (section 4.2) and secure it against unintentional restart.
2. Let the hydraulic fluid cool down until the tank enclosure is warm to the touch.
3. Remove the grating (Figure 28).

Figure 28: Changing hydraulic fluid.

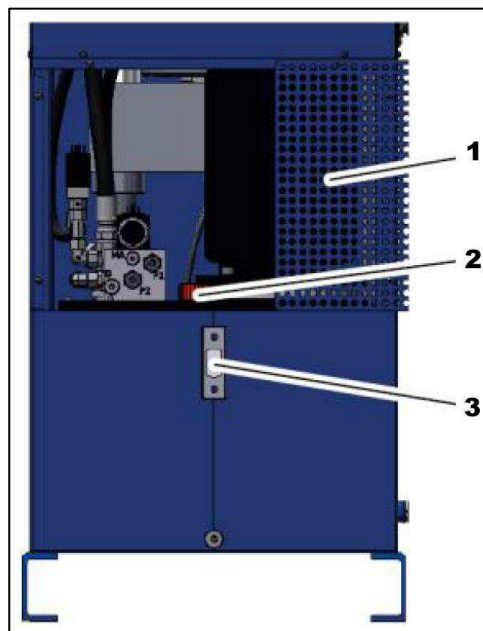

- 1** Grating
- 2** Fill cap
- 3** Fill level indicator

4. Open the fill cap.
5. Pump out hydraulic fluid with an external pump.
6. Begin adding hydraulic fluid. (For quantity and type, refer to Table 4 on page 11.)
7. Continue adding fluid until the level reaches the center of the fill level indicator.
8. Close the fill cap.

9. Reinstall the grating.
10. Wait at least four hours to allow dirt particles in the system to settle.
11. Turn on the machine (section 4.1).
12. Operate the machine in the idle mode for two minutes.
13. Run the tool several times to bleed the hydraulic fluid system.
14. Verify that the fluid level is at the center of the fill level indicator. Add hydraulic fluid if necessary.
15. Dispose of the hydraulic fluid in compliance with the applicable local environmental protection regulations.

6.3 Cleaning



CAUTION

Do not use a steam jet or compressed air to clean the machine. Doing so can cause dirt or water to enter the machine, resulting in serious damage.

1. Remove the crimping dies and the intermediate dies.
2. Vacuum the machine (or clean it with a soft cloth) to remove metal fragments (crimping scale) from the opened crimping tool.
3. Reinstall the crimping dies and the intermediate dies.

6.4 Changing the crimping dies with the Quick Die Change (QDC) tool

Always use a complete set of equal crimping dies with the same identification and diameter. A complete set consists of eight dies in one of the following combinations:

- Eight crimping dies
- Seven crimping dies and one matching marking die



DANGER

Do not wear jewelry, loose clothing, or long hair that can catch in moving parts of the equipment.

1. On the control panel, touch the QDC button (Figure 29) to select the change position for crimping dies.

Figure 29: QDC button.

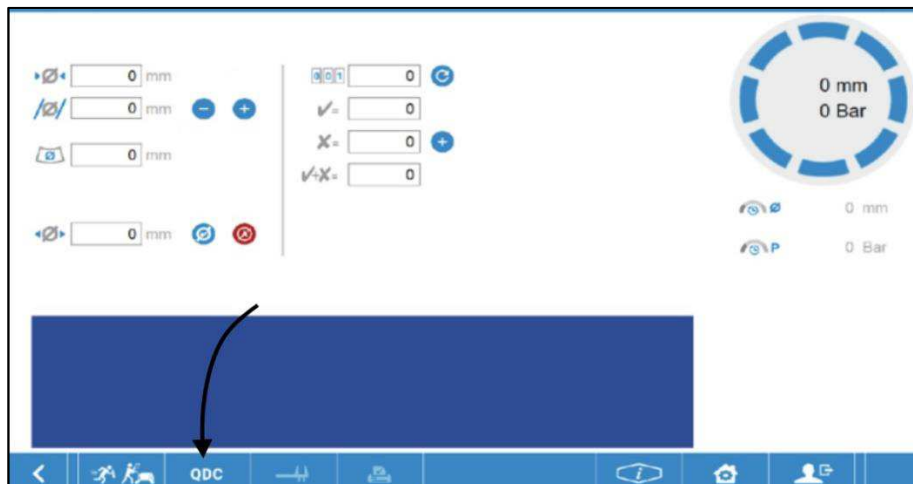

2. Touch the **Open** button to open the crimping tool just far enough to insert the dies.
3. Push the eight pins of the QDC tool into the front holes of the crimping dies (Figure 30).

Figure 30: Changing the crimping dies.

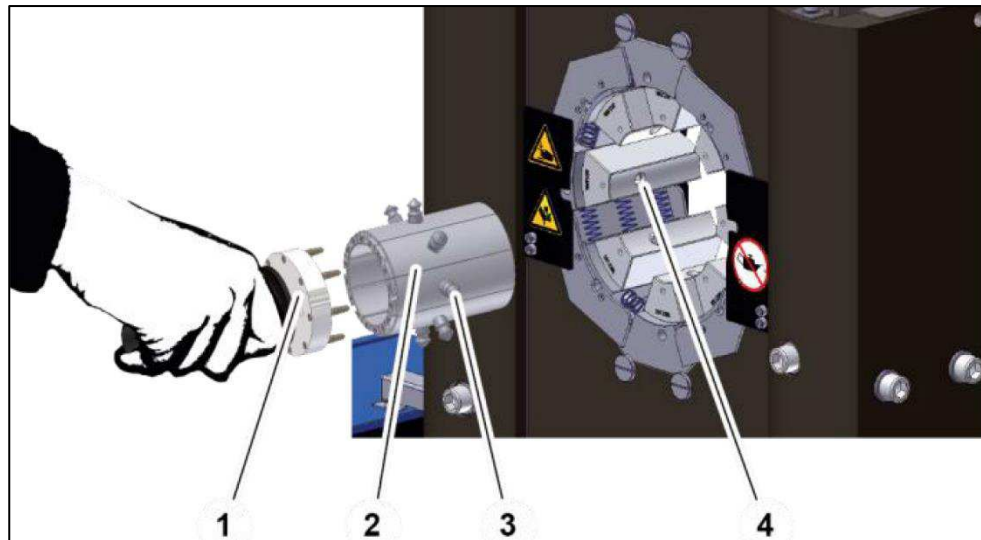

- 1 QDC tool
- 2 Crimping dies
- 3 Retaining bolts
- 4 Mounting hole

4. Rotate the QDC tool counter-clockwise.
5. Check the retaining bolts of the crimping dies for damage. Replace if necessary.
6. Insert the QDC tool with crimping dies into the center of the crimping tool.



CAUTION

The retaining bolts **must** fit in the mounting hole of the base dies or intermediate dies. If they do not fit, the retaining bolts and the crimping dies will be destroyed.



DANGER

Moving parts can crush and cut. Keep hands clear to avoid injury.

7. Press the button to close the tool.
 - All retaining bolts **must** slide into the relevant mounting hole of the basic or intermediate dies.
 - The spring-mounted pressure pieces **must** engage into the retaining bolts.
8. Remove the QDC tool from the dies.
9. Verify that the crimping dies fit tightly. If they do not, remove the dies, inspect them, and try again.
10. Proceed in reverse order to remove the crimping dies.

11. Place the crimping die in the base or intermediate die so that it does not protrude too far (Figure 31).



CAUTION

If the crimping dies protrude beyond the basic and intermediate dies, the dies and the machine will be damaged.

Figure 31: Crimping die placement.

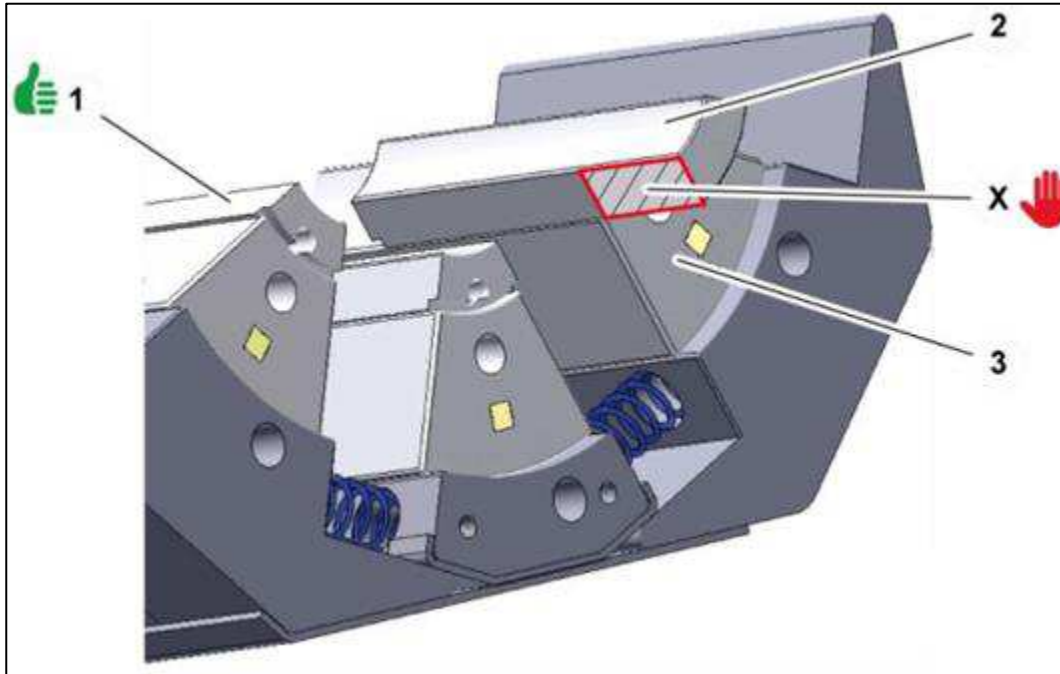

- 1** Correctly installed crimping die
- 2** Incorrectly installed crimping die
- 3** Base or intermediate die
- X** Protrudes beyond base or intermediate dies

6.5 Checking and replacing the slide bearing plates



CAUTION

Worn slide bearing plates can damage the machine and cause inaccurate Press Diameters.

Check slide bearing plates for wear on a regular basis (see Table 13 on page 35). Figure 32 shows the wear pattern to look for.

Figure 32: Slide bearing plates.

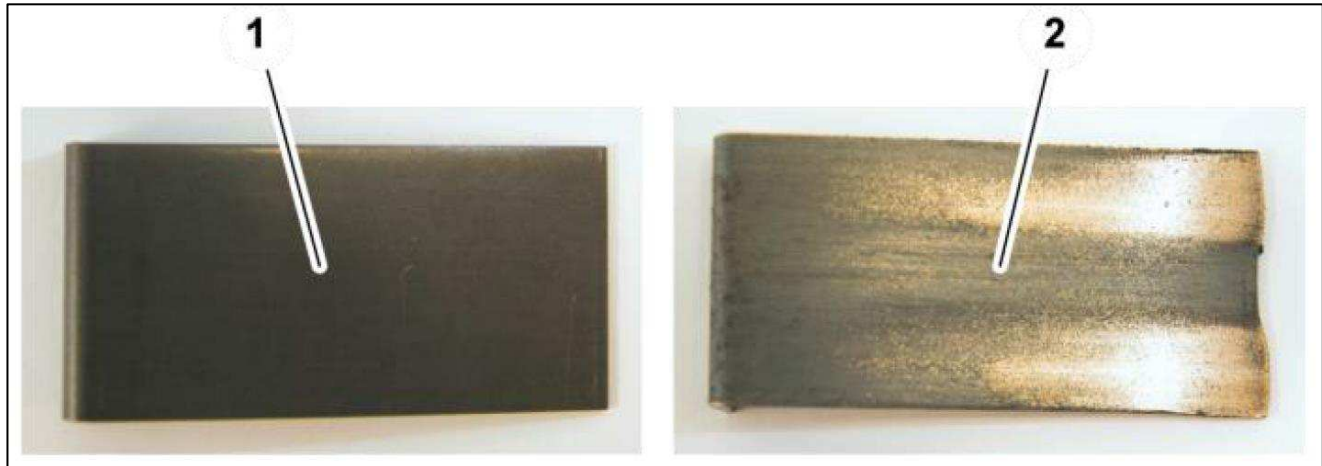

- 1** New
- 2** Worn

Replace worn plates with new ones. You will need the spare part sets listed in Table 15.

Table 15: Spare part sets.

TE PNs	Description
5-2234018-5	Slide Plates
5-2234018-6	Springs
5-2234018-8	Shims
6-2234018-0	Guiding plates

The new slide bearing plates have two different surfaces.

- The side with the White, Grey, or Red coating is the surface for the dies.
- The shiny metal side of the plate is the back side.



Lock out electrical power when performing maintenance or repair on this equipment.

1. Open the crimping tool fully.
2. Turn off the main power switch (section 4.2).
3. Secure the machine against unintentional restart.

4. Loosen the screws that secure the protective plates (Figure 33). Each plate has four screws at the front and four at the back.

Figure 33: Plates and hexagon socket screws.

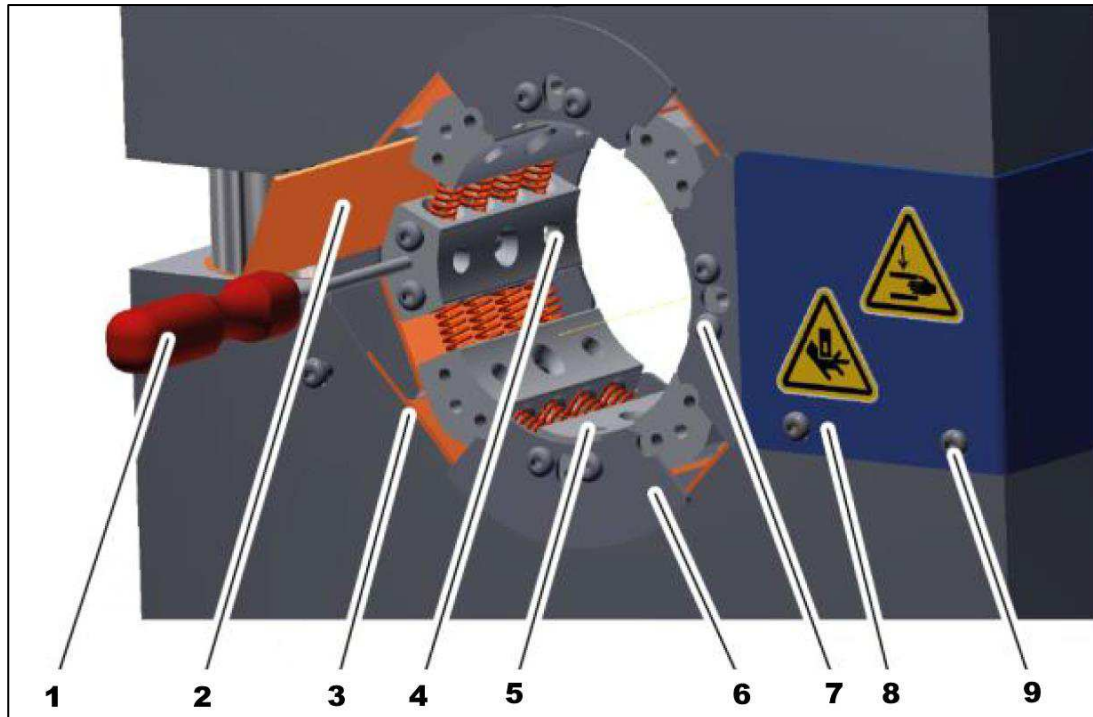

- | | |
|---|--|
| 1 Screwdriver | 6 Guiding plates |
| 2 Master bearing plates | 7 Screws securing the guiding plates |
| 3 Secondary bearing plates | 8 Protective plates |
| 4 Master dies | 9 Screws securing the protective plates |
| 5 Inside screws securing the base dies | |

5. Remove the protective plates.
6. Loosen the screws that secure the guiding plates. Each plate has eight screws (with adjusting washers) at the front and eight at the back.
7. Remove the guiding plates.
8. Slightly loosen both inside screws in the 3, 6, 9, and 12 o'clock base dies by two revolutions.
9. Use the new secondary bearing plates to push out the old secondary bearing plates.
10. Slightly lift the master dies with a screwdriver and press the eight new master bearing plates against the old slide bearing plate at the front. The old slide bearing plates are pushed out of the tool.
11. Reinstall the screws in the base dies and tighten them to the torque for M5 MA = 8 Nm.
12. Reassemble the guiding plates and protective plates in reverse order.
13. Use grease to affix one adjusting washer on each base die before the guiding plates are screwed on.
14. Perform a crimping test run and check the crimped terminal.
15. Re-calibrate the machine (see section 6.7).

i **NOTE**
Shims, if any, must be reinstalled at the same location.

6.6 Replacing the relay/opto-coupler



Lock out electrical power when performing maintenance or repair on this equipment.

1. Turn off the main power switch (section 4.2).
2. Secure the machine against unintentional restart.
3. Open the control cabinet.
4. Open the flap 90°.
5. Press down on the hinge with the opened flap (Figure 34). The relay/opto-coupler springs up.

Figure 34: Ejecting the relay/opto-coupler.

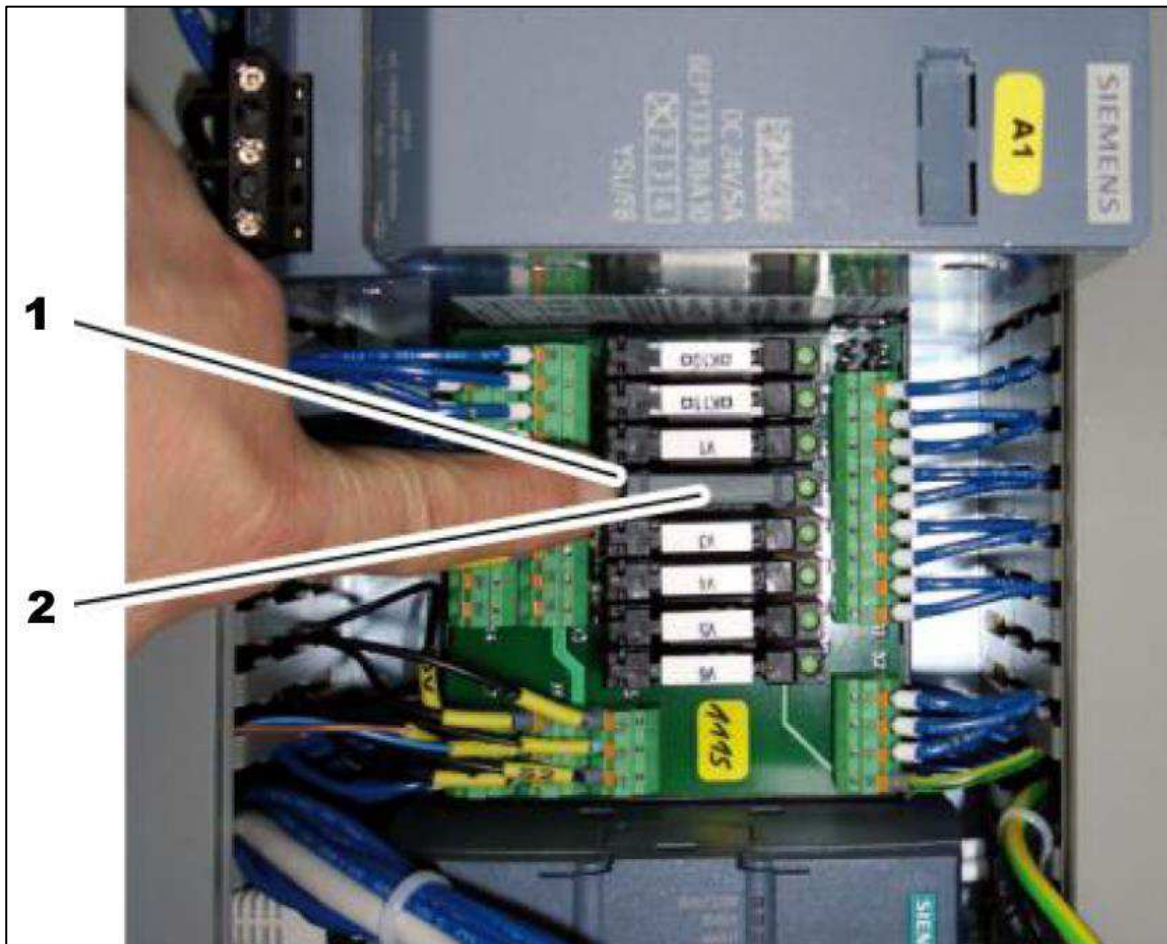

- 1 Hinge
- 2 Relay/opto-coupler

6. Remove the relay/opto-coupler.
7. Install the new relay/opto-coupler.
8. Close the flap.

6.7 Calibration

During calibration, the zero point and the crimping tool inclination are set. This is required if the slide bearing plates have been replaced (section 6.5).

1. On the Start screen, touch the **Machine Settings** button (Figure 35).

Figure 35: Machine Settings button.



2. The login screen is displayed. Enter your username and password. Touch the **Log In** button (Figure 36).

Figure 36: Log In button.

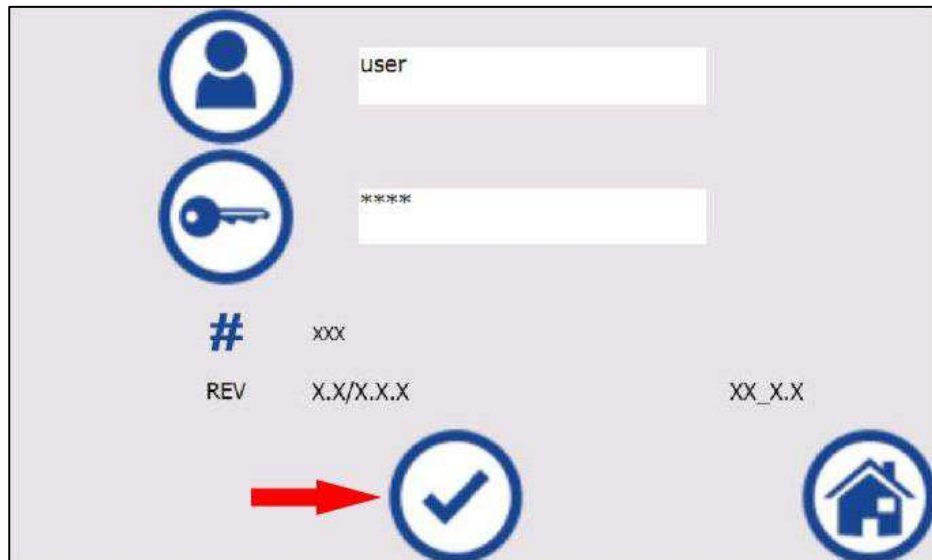

- The Database screen is displayed. Touch the **Next Screen** button (Figure 37) to advance to the next machine settings screen.

Figure 37: Next Screen button.

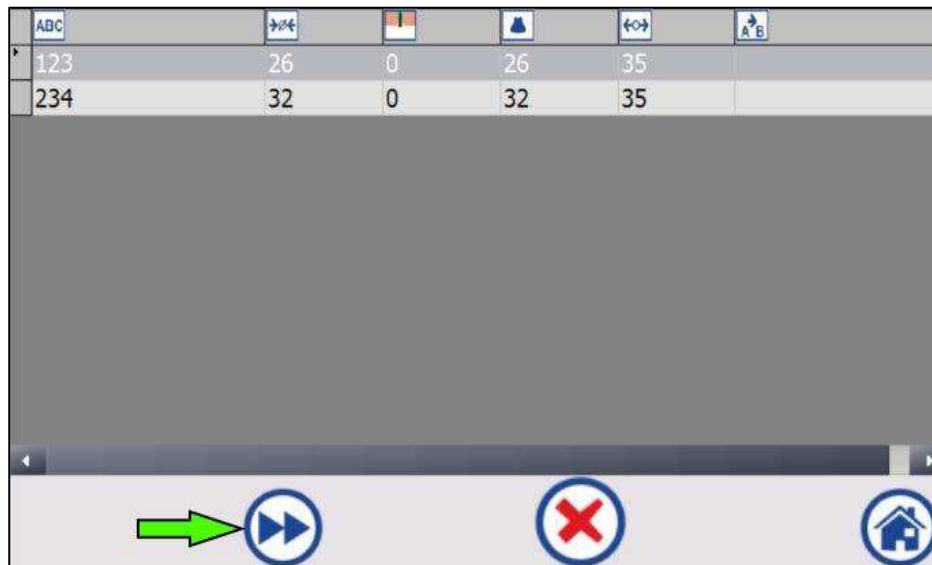

- Touch the **Next Screen** button repeatedly to advance through the machine settings screens until the Calibration screen is displayed (Figure 38).

Figure 38: Calibration screen.

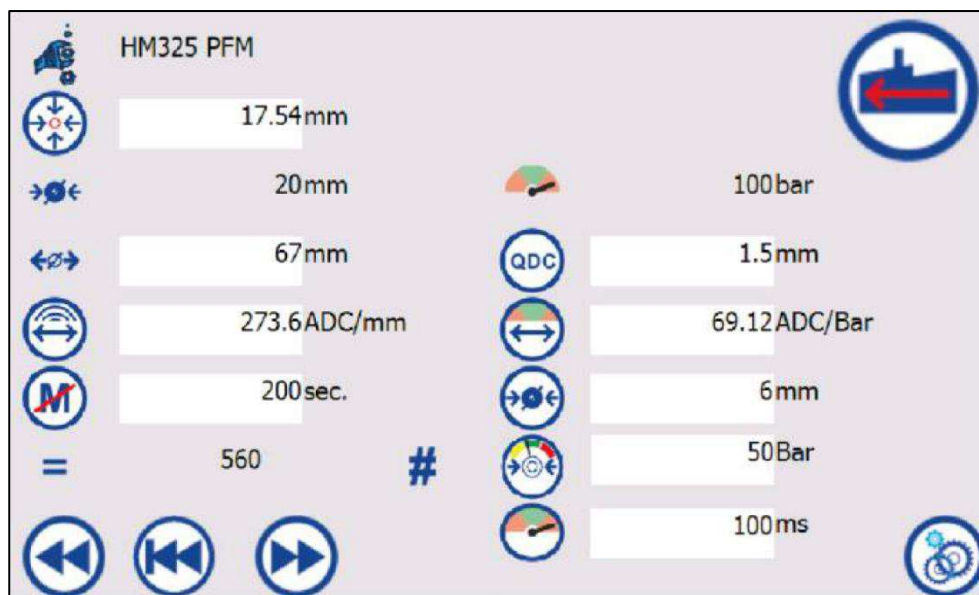

- Select a calibration pin (PN 2461008-1) (Figure 39) with the indicated measurement (Figure 40).

Figure 39: Calibration pin.

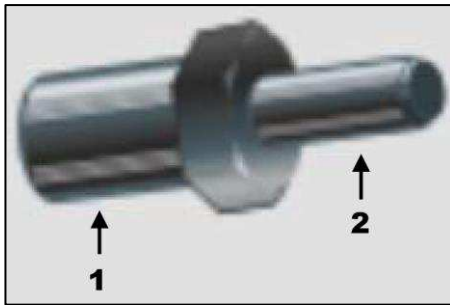

- 1** Thick end
- 2** Thin end

Figure 40: Calibration pin measurement.

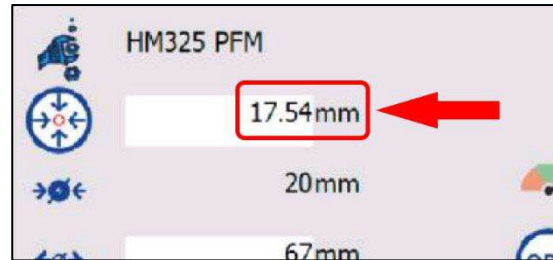

6. Insert crimping dies with the indicated size.
7. Insert the thin end of the pin into the crimping tool.
8. Touch the Close button (Figure 41). The machine reaches the calibration pressure.

Figure 41: Open and close buttons.

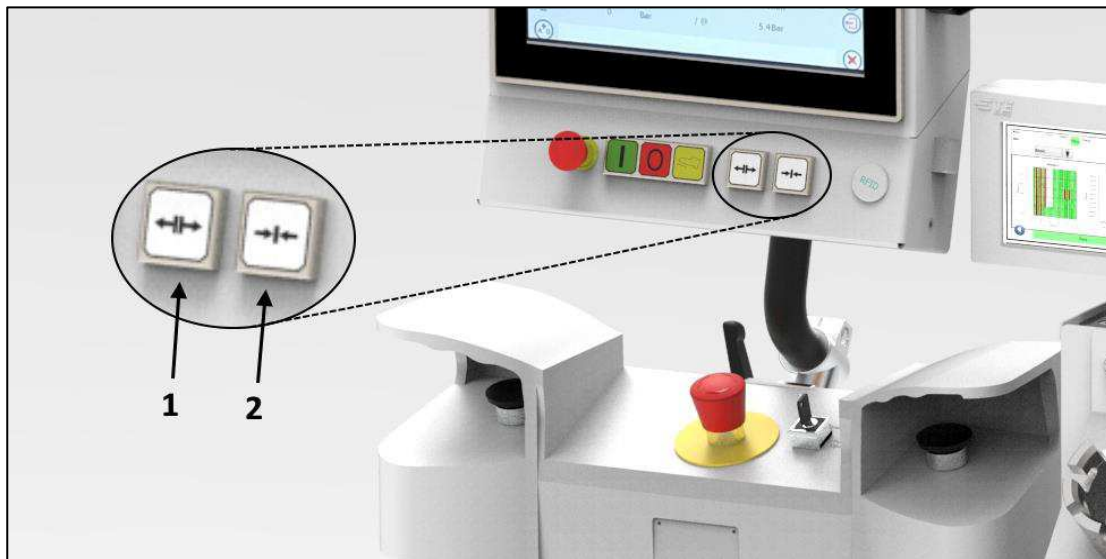

- 1** Open button
- 2** Close button

9. Insert the thick end of the pin into the crimping tool.
10. Touch the Close button. The machine reaches the calibration pressure. The calibrated zero point is displayed (Figure 42).

Figure 42: Calibrated zero point.



6.8 CMK Function >Machine capability index

1. Touch the **Forming to a defined diameter** button (see section 2.4.1). Enter the CMK settings on the Control Panel screen (Figure 43), setting the parameters described in Table 16.

Figure 43: Entering CMK settings.

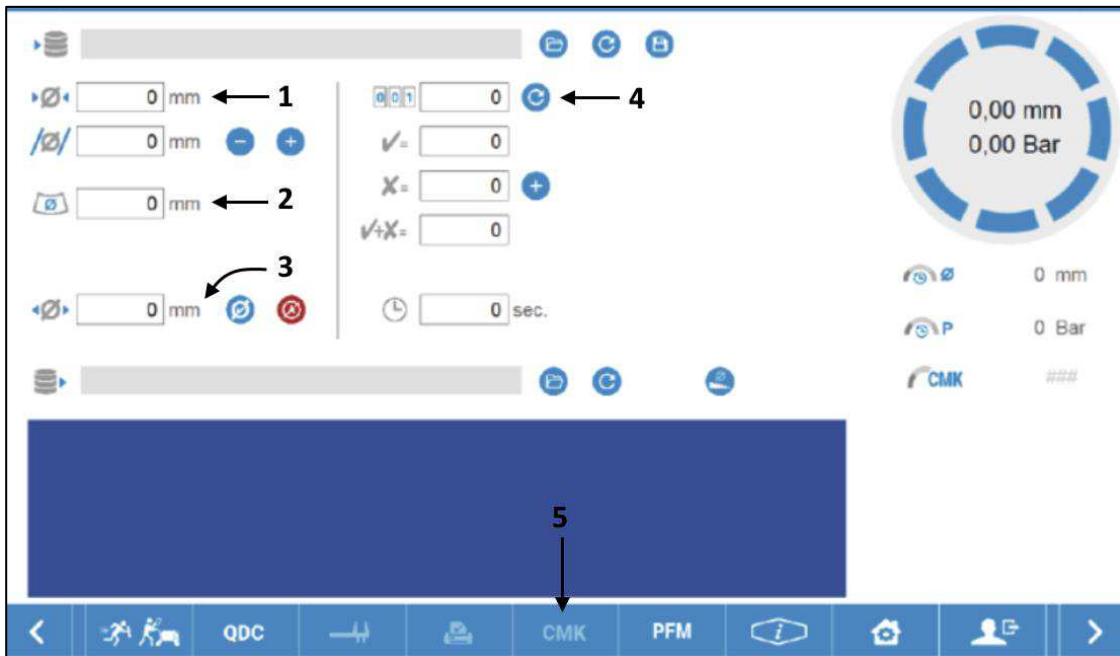

- 1 Forming dimension diameter
- 2 Crimping die diameter
- 3 Opening diameter
- 4 Number of work pieces
- 5 CMK Button

Table 16: CMK settings.

Setting	Value
Forming dimension diameter	31.7 mm <i>Must be smaller than the crimping die diameter, so force (between 55-70 bar) can be built up</i>
Crimp diameter	32 mm
Opening diameter	As small as possible to save time (for example: 45mm)
Number of work pieces	50

2. Touch the **CMK** button.
3. Check the values and activated **CMK function** (Figure 44).

Figure 44: CMK screen.

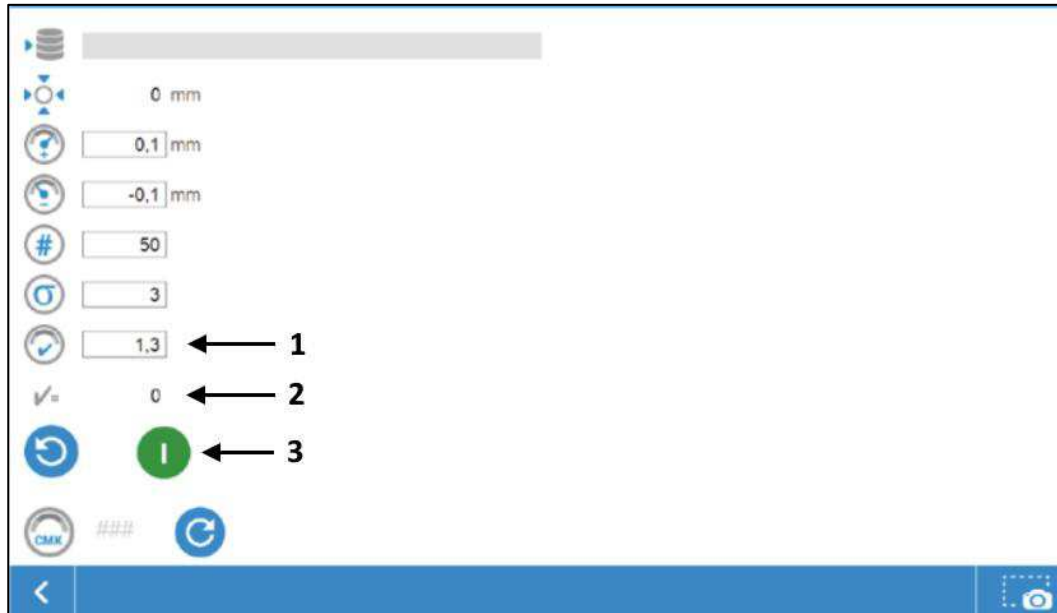

- 1 CMK target value
- 2 Completed quantity
- 3 CMK function

Table 17: CMK values.

Setting	Value
CMK target value	Must be 2
Completed quantity	Number of forming processes completed so far.
CMK function	CMK activated

4. Place the ring or calibration gauge in the die set and start crimping.
 - by using the ring, replace a new ring in the die set after each pressing.
5. After 50 crimps the machine calculates the CMK value (must be >2)

i **NOTE**
 Not necessary by using the calibration gauge.

7 Troubleshooting

Table 18: Troubleshooting.

Problem	Cause	Remedy
Machine does not close or open	Main switch is OFF	Turn switch ON
	Incorrect voltage	Check voltage supply
	Defective power plug	Replace plug
	Electric motor is rotating in the wrong direction	Correct electrical connection
	Low hydraulic fluid level	Add fluid
	Defective power unit	Replace power unit
	Defective operation buttons	Replace buttons
Uneven or conical crimp	Worn bearing plates	Replace plates
	Damaged base dies	Replace base dies
	Damaged crimping dies	Replace crimping dies
	Crimping area not centered	Position terminal in center of crimping length
Crimping dimension is wrong	Worn bearing plates	Replace plates
	Leak or defect in pump or pipe	Check hydraulic pressure at the hydraulic manifold measuring point. Repair or replace as needed.
	Wrong crimping dies used	Check die diameter and profile (see section 3.4)

8 Error message

If the machine uses an oil filter and this filter is contaminated, an error message is displayed:

Oil filter contaminated.

To correct the problem, complete the following steps.

1. Replace the oil filter.
2. Touch the **OK** button to clear the error message.



NOTE

If you touch the OK button without replacing the oil filter, the message is displayed again when the motor restarts.



NOTE

The error message can also be displayed if the ambient temperature is low. Operate the machine in the idle mode for several minutes. If the message is displayed again after restart, replace the oil filter.

9 Decommissioning and disposal

9.1 Decommissioning

**DANGER**

Turn off the main power switch and disconnect the electrical cord from the power source before decommissioning the machine.

**DANGER**

Hydraulic fluid can injure the skin, eyes, respiratory system, and intestinal tract. Wear protective equipment. Refer to the supplier's data sheet for protection and safety instructions. Ensure good ventilation and do not eat, drink, or smoke in the working area.

**CAUTION**

Spilled hydraulic fluid creates a slipping and falling hazard. Clean up any spills immediately.

**CAUTION**

Hydraulic fluid is flammable. Fluid spray or spills create a fire hazard. Keep ignition sources (such as welding, cutting, or soldering work) away from the machine during hydraulic fluid filling. Do not smoke in the working area.

**CAUTION**

Parts of the machine might be under pressure or tension. To avoid injury, depressurize the machine and check for potential sources of hazard before performing any work.

This section describes how to safely decommission the machine. The machine must be decommissioned only by entrusted and qualified staff.

1. Disassemble the entire machine.
2. Deactivate the hydraulic pump and secure it against unintentional restart.
3. Relieve the hydraulic pressure manually, if necessary.
4. Open all bolted hydraulic connections slowly and carefully.
5. Pump out all hydraulic fluid with an external pump.

9.2 Disposal

The machine contains metal, hydraulic hoses, electric cables, and electronic components, depending on the type. Comply with all applicable national environmental protection and waste disposal regulations.

Observe applicable national environmental protection and waste disposal regulations.

Observe the information given on the safety data sheet.

10 Replacement and repair



DANGER

To avoid personal injury, **always** remove the battery from the tool **before** performing any maintenance on the crimping tool.

Customer-replaceable parts are listed in the product drawing. Stock and control a complete inventory to prevent lost time when replacement of parts is necessary. Parts other than those listed should be replaced by TE Connectivity to ensure quality and reliability. Order replacement dies through your TE representative or go to TE.com and click the **Shop TE Store** link at the top of the page.

For field service, go to the [Service and Repair](#) page on the TE website, or send an e-mail to the address for your region in Table 19.

Figure 45: Service and repair.



Table 19: Field service e-mail addresses.

Region	Address
Asia	Tefe1ap@te.com
EMEA (including India)	Tefe1@te.com
North America	Fieldservicesnorthamerica@te.com
South America	FSE@te.com

11 Diagrams

11.1 Electric diagram

The electrical diagram of the machine is not yet available at the time of publishing this manual. Contact TE for further information.

11.2 Hydraulic diagram

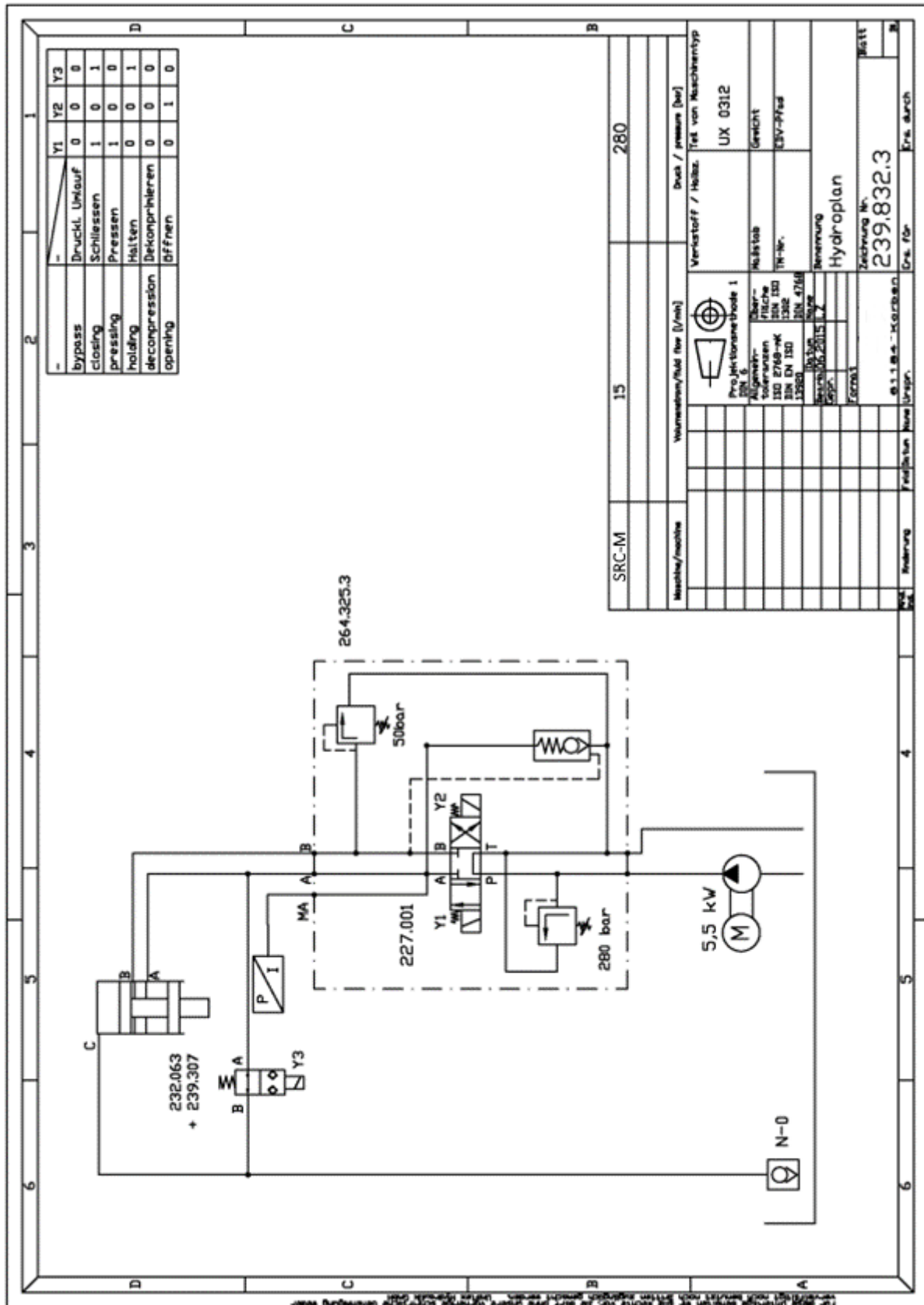

12.2 Declaration of qualified staff

I herewith declare that I have attended an internal training for the operation of the machine and have been informed on all safety-related details. In addition, I declare that I have read and understood this Operation Manual completely.

City	Date	Name	Signature

13 Revision summary

REV	REVISION RECORD	DRAWN	DATE
A	Initial Release	Berry, Patrick	23Jun2023
B	Figures-2,3,8,9,11,18,21,25,28 and 40 were replaced with the new images, Section 6.8 CMK Function, is added, Table numbers are updated.	Veerasamy, Gobinath	10Jan2024
C	Added new Section 2.1, 2.1.1, Section 2.3, 2.3.1, 2.3.2, 10 & 11.2 updated, Figure 3, Figure 5, Figure 8 & Figure 31 updated, Table 10, Table 13 & Table 15 updated.	Huang, Kelly	30May2024