



T2212 PRINTER

Type
T2212-PRINTER
T2212-SWARE-PRINTER

Doc. # 412-121037 revision 1

Copyright

This documentation as well as translation hereof are property of TE Connectivity.

The replication, conversion, duplication or divulgement of the whole manual or parts of it for other intentions than its original intended purpose demand the previous written authorization by TE Connectivity.

Trademark

Windows is a registered trademark of the Microsoft Corporation.

Editor

Regarding questions or comments please contact TE Connectivity.

Topicality

Due to the constant further development of our products discrepancies between documentation and products can occur.

Please check with your local TE Connectivity Representative for the latest update.

1	Introduction	4
1.1	Instructions.....	4
1.2	Intended Use.....	4
1.3	Safety Instructions.....	5
1.4	Environment.....	5
2	Installation	6
2.1	Device Overview	6
2.2	Unpacking and Setting-up the Printer	8
2.3	Connecting the Device.....	8
2.3.1	Connecting to the Power Supply	8
2.3.2	Connecting to a Computer or Computer Network	8
2.4	Switching on the Device.....	8
3	Touchscreen-Display	9
3.1	Start Screen	9
3.2	Navigation in the Menu	11
4	Loading Material.....	12
4.1	Loading Media from a Roll	12
4.2	Adjusting the Label Sensor	13
4.3	Loading Transfer Ribbon.....	14
4.4	Setting the Feed Path of the Transfer Ribbon.....	15
5	Printing Operation.....	16
5.1	Printing in Tear-off Mode	16
5.2	Printing in Cutting Mode.....	16
6	Cleaning	17
6.1	Cleaning Information	17
6.2	Cleaning the Print Roller.....	17
6.3	Cleaning the Printhead.....	18
7	Fault Correction	19
7.1	Error Display	19
7.2	Error Messages and Fault Correction	19
7.3	Problem Solution.....	21
8	Licenses.....	22
8.1	Reference to the EU Declaration of Conformity	22
8.2	FCC.....	22
9	Index.....	23

1.1 Instructions

Important information and instructions in this documentation are designated as follows:

**Danger!**

Draws attention to an exceptionally grave, imminent danger to your health or life due to hazardous voltages.

**Danger!**

Draws attention to a danger with high risk which, if not avoided, may result in death or serious injury.

**Caution!**

Draws attention to a danger with low risk which, if not avoided, may result in minor or moderate injury.

**Attention!**

Draws attention to potential risks of property damage or loss of quality.

**Note!**

Advices to make work routine easier or on important steps to be carried out.

**Environment!**

Gives you tips on protecting the environment.



Handling instruction



Reference to section, position, illustration number or document.



Option (accessories, peripheral equipment, special fittings).

Time

Information in the display.

1.2 Intended Use

- The device is manufactured in accordance with the current technological status and the recognized safety rules. However, danger to the life and limb of the user or third parties and/or damage to the device and other tangible assets can arise during use.
- The device may only be used for its intended purpose and if it is in perfect working order, and it must be used with regard to safety and dangers as stated in the operating manual.
- The device printer is intended exclusively for printing suitable materials that have been approved by the manufacturer. Any other use or use going beyond this shall be regarded as improper use. The manufacturer/supplier shall not be liable for damage resulting from unauthorized use; the user shall bear the risk alone.
- Usage for the intended purpose also includes complying with the operating manual, including the manufacturer's maintenance recommendations and specifications.

**Note!**

Further documentation are included on the DVD enclosed in the printer box, and can be found on www.te.com/identification.

1.3 Safety Instructions

- The device is configured for voltages of 100 to 240 V AC. It only has to be plugged into a grounded socket.
- Only connect the device to other devices which have a protective low voltage.
- Switch off all affected devices (computer, printer, accessories) before connecting or disconnecting.
- The device may only be used in a dry environment, do not expose it to moisture (sprays of water, mists, etc.).
- Do not use the device in an explosive atmosphere.
- Do not use the device close to high-voltage power lines.
- If the device is operated with the cover open, ensure that people's clothing, hair, jewelry etc. does not come into contact with the exposed rotating parts.
- The device or parts of it can become hot while printing. Do not touch during operation, and allow it to cool down before changing material and before disassembly.
- Risk of crushing limbs and/or fingers when closing the cover. Only touch the cover on the outside. Do not reach into the swivel range of the cover.
- Perform only those actions described in this operating manual.
Work going beyond this may only be performed by trained personnel or service technicians.
- Unauthorized interference with electronic modules or their software can cause malfunctions.
- Other unauthorized work on, or modifications to, the device can also endanger operational safety.
- Always have service work done by a qualified workshop, where the personnel have the technical knowledge and tools required to do the necessary work.
- There are various warning stickers on the device. They draw your attention to danger.
Warning stickers may therefore not be removed, because you and other people will not be made aware of pending dangers and may be injured.
- The maximum noise level is under 0.063 Pa/70 dB(A).

**Danger!**

Danger to life and limb from the power supply.

- ▶ Do not open the device casing.

**Warning!**

This is a class A product. In a domestic environment this product may cause radio interference in which case the user may be required to take adequate measures.

1.4 Environment



Obsolete devices contain valuable recyclable materials that should be sent for recycling.

- ▶ Send to suitable collection points, separately from residual waste.

The modular construction of the printer enables it to be easily disassembled into its component parts.

- ▶ Send the parts for recycling.



The electronic circuit board of the device is equipped with a lithium battery.

- ▶ Take old batteries to collection boxes in shops or public waste disposal centres.

2.1 Device Overview

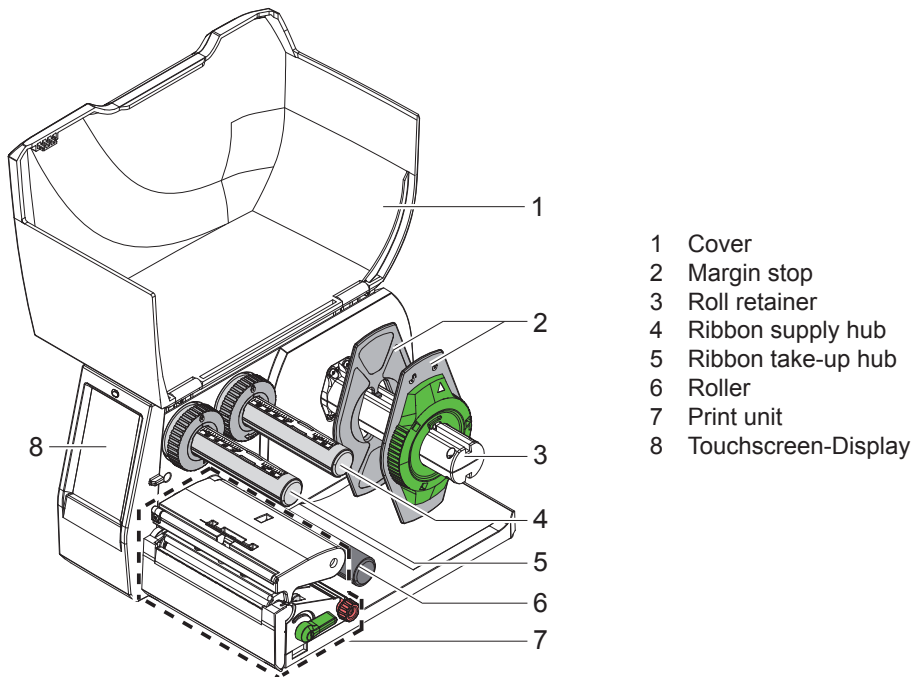

Figure 1 Overview

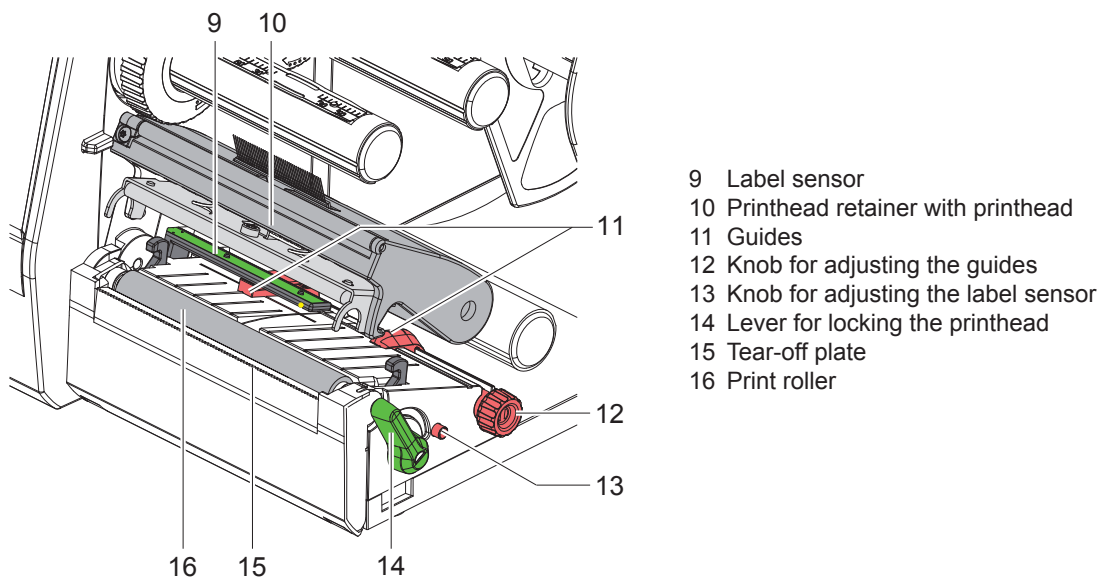
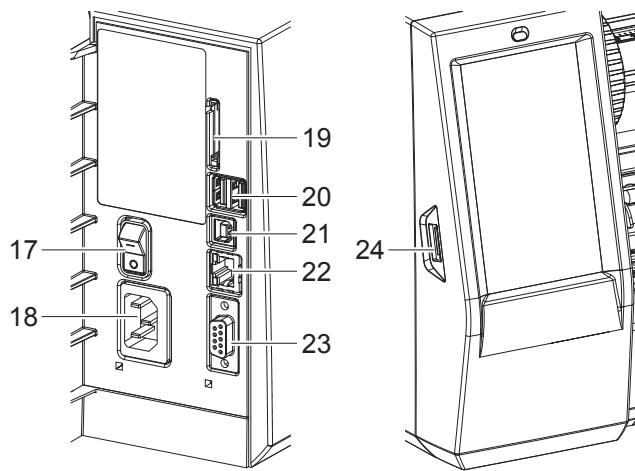

Figure 2 Print unit



- 17 Power switch
- 18 Power connection jack
- 19 Slot for SD card
- 20 2 USB master ports for keyboard, scanner, USB memory stick, Bluetooth adapter, service key or WiFi stick
- 21 USB full-speed slave port
- 22 Ethernet 10/100 Base-T
- 23 Serial RS-232 port
- 24 USB master port for service key or USB memory stick

Figure 3 Connections

2.2 Unpacking and Setting-up the Printer

- ▶ Lift the label printer out of the box.
- ▶ Check label printer for damage which may have occurred during transport.
- ▶ Set up printer on a level surface.
- ▶ Remove foam transportation safeguards near the printhead.
- ▶ Check delivery for completeness.

Contents of delivery:

- T2212-PRINTER
- Power cables
- USB cable
- Operator's Manual
- DVD with Windows driver and documentation



Note!

Please keep the original packaging in case the printer must be returned.

In the event a printer is returned please ensure all printing materials are removed from the printer before shipping.



Attention!

The device and printing materials will be damaged by moisture.

- ▶ **Set up label printers only in dry locations protected from moisture.**

2.3 Connecting the Device

The standard available interfaces and connectors are shown in Figure 3.

2.3.1 Connecting to the Power Supply

The printer is equipped with a wide area power unit. The device can be operated with a supply voltage of 100-240 V~/50-60 Hz without adjustment.

1. Check that the device is switched off.
2. Plug the power cable into the power connection socket (18/Figure 3).
3. Plug the power cable into a grounded socket.

2.3.2 Connecting to a Computer or Computer Network



Attention!

Inadequate or no grounding can cause malfunctions during operations.

Ensure that all computers and cables connected to the label printer are grounded.

- ▶ Connect the printer to a computer or network with a suitable cable.

To connect the printer please consult the Quick start guide (TE document 411-121061) found in the cover of the Printer CD case.

2.4 Switching on the Device

When all connections have been made:

- ▶ Switch the printer on at the power switch (17/Figure 3).
The printer performs a system test, and then shows the system status *Ready* in the display.

The user can control the operation of the printer with the control panel, for example:

- Issuing, interrupting, continuing and canceling print jobs,
- Setting printing parameters, e.g. heat level of the printhead, print speed, interface configuration, language and time of day.
- Control stand-alone operation with a memory module.
- Update the firmware..

Many functions and settings can also be controlled by software applications or by direct programming with a computer using the printer's own commands.

Settings made on the touchscreen display set the basic settings of the printer.



Note!

It is advantageous, whenever possible, to make adjustments to various print jobs in the software.

3.1 Start Screen

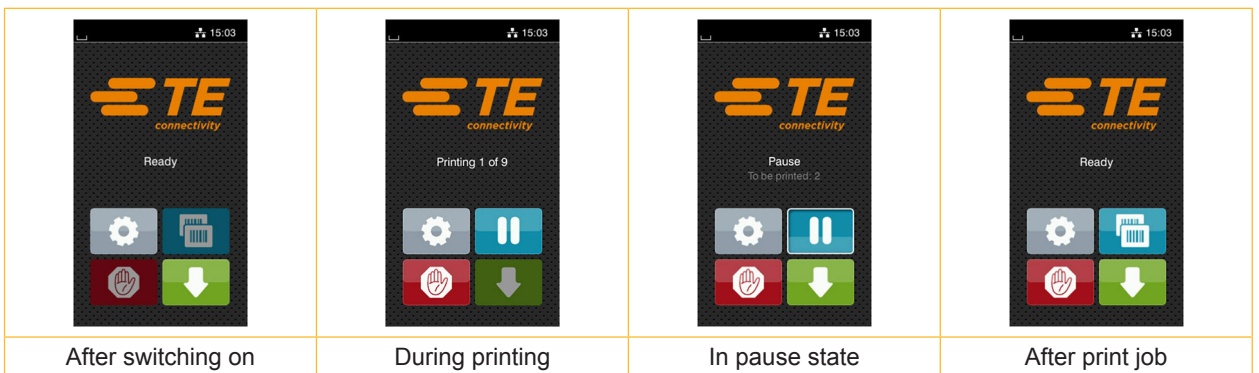

Figure 4 Start screen

The touchscreen display is operated by touch:

- To open a menu or select a menu item lightly touch the corresponding symbol.
- To scroll in lists slide finger up or down on the display.

	Open the menu		Repeat the last printed label
	Interrupt the print job		Cancel all print jobs
	Continue the print job		Feed a blank label

Table 1 Symbols on the start screen



Note!

Inactive symbols are shaded.

With special software or hardware configurations additional symbols appear on the start screen:

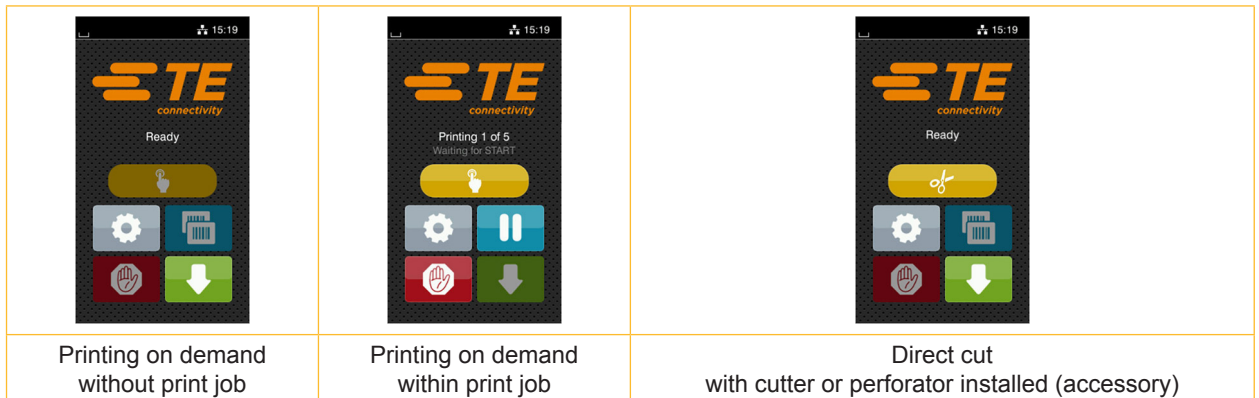

Figure 5 Optional symbols on the start screen

	Initiate the printing of a single label within a print job including cutting, perforating...		Release a direct cut without media feed
--	--	--	---

Table 2 Optional symbols on the start screen

Depending on the configuration a range of information is visible via several icons in the status bar:

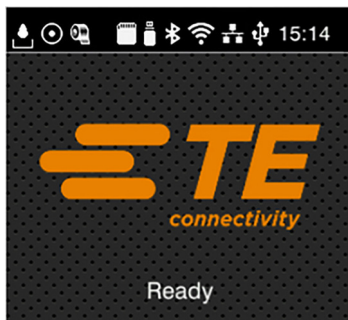

Figure 6 Icons of the status bar

	Displays the current data transfer in the form of a falling drop.
	The <i>Save data stream</i> function is active All received data are stored in a .lbl file.
	Warning ribbon end The remaining ribbon is below the required amount
	SD card installed
	USB memory installed
	Gray: Bluetooth adapter installed, White: Bluetooth connection active
	WiFi connection active The WiFi strength is displayed by the number of white arcs.
	Ethernet connection active
	USB connection active
	abc program active
	Clock time

Table 3 Icons on the status bar

3.2 Navigation in the Menu

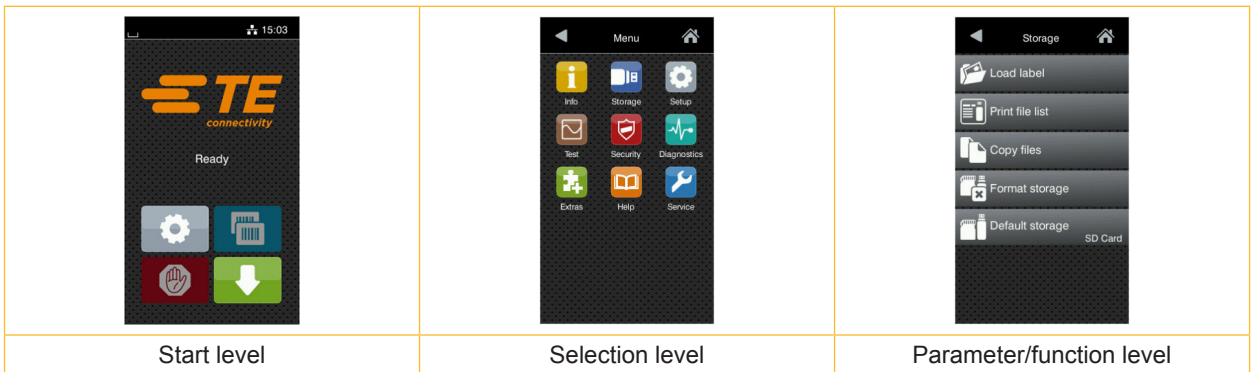





Figure 7 Menu levels

- ▶ To open the menu select  on the start screen.
- ▶ Select a theme in the selection level. Several themes have substructures again with selection levels. To return from the current level to the upper one select . To leave the menu select .
- ▶ Continue the selection until the parameter/function level is reached.
- ▶ Select function. The printer may perform a function after a preparatory dialog, if necessary.
 - or -
 - Select parameter. The setting options depend on the type of parameter.

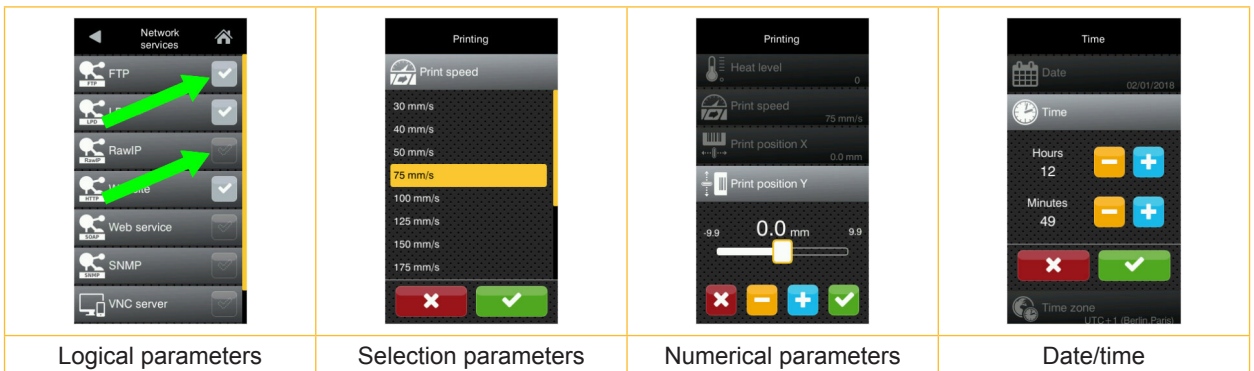

Figure 8 Samples for parameter setting







	Scroll bar for rough value setting
	Decreasing the value step-by-step
	Increasing the value step-by-step
	Return without saving the setting
	Return and save settings
	Parameter is disabled, touching enables the parameter
	Parameter is enabled, touching disables the parameter

Table 4 Buttons for setting parameters

4.1 Loading Media from a Roll

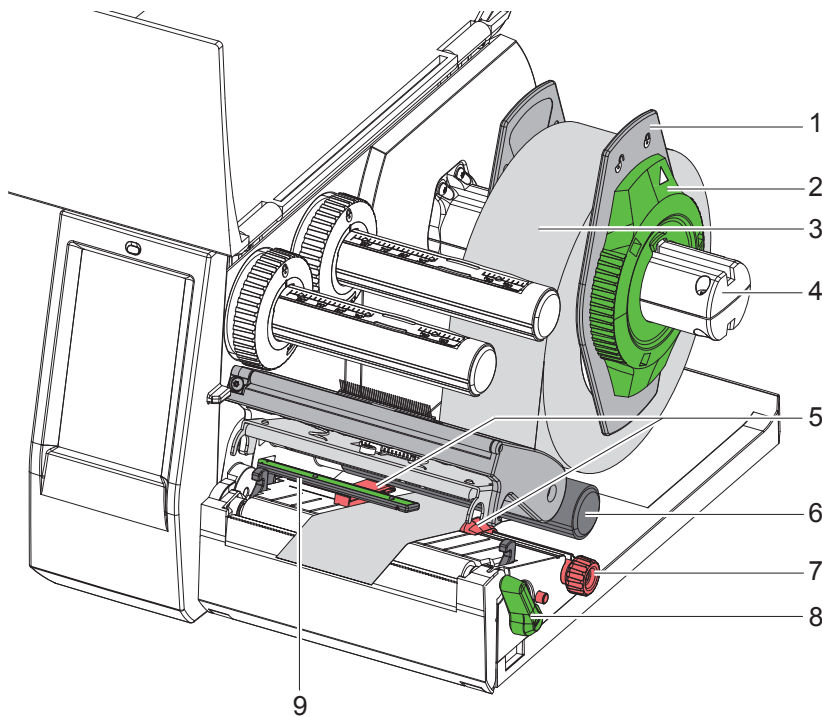



Figure 9 Loading media from a roll

1. Open cover.
2. Turn ring (2) of the margin stop (1) counterclockwise, so that the arrow points to the symbol , and thus release the margin stop.
3. Remove the margin stop (1) from the roll retainer (4).
4. Load label roll (3) on the roll retainer (4) in such a way that the labels can be inserted into the printhead in the correct position. The printable side of the labels must be visible from above.
5. Re-mount the margin stop (1) onto the roll retainer (4). Push the margin stop (1) to the roll (3) until the roll touches both margin stops and a clear resistance is encountered.
6. Turn ring (2) clockwise, so that the arrow points to the symbol , and thus fix the margin stop (1) on the roll retainer (4).
7. Turn lever (8) counterclockwise to open printhead.
8. Position guides (5) by turning the knob (7) so that they are several millimeters wider than the material.
9. Position material below the roller (6) and guide it through the print unit.

**Attention!**

- ▶ Guide material through the print unit below the label sensor (9).

10. Move guides (5) close to the edges of the material without clamping the material.
11. Adjust label sensor (▷ 4.2 on page 13).
12. Press printhead retainer down and turn lever (8) clockwise to lock the printhead.

4.2 Adjusting the Label Sensor

**Note!**

When the printer is delivered the label sensor is positioned in the middle of the paper feed. Thus, the label sensor must only be adjusted if materials with the following characteristics are used:

- Material with reflex or cut-out marks, which are not in the middle.
- Multi-column material with an even number of columns.
- Material with irregularly shaped labels.

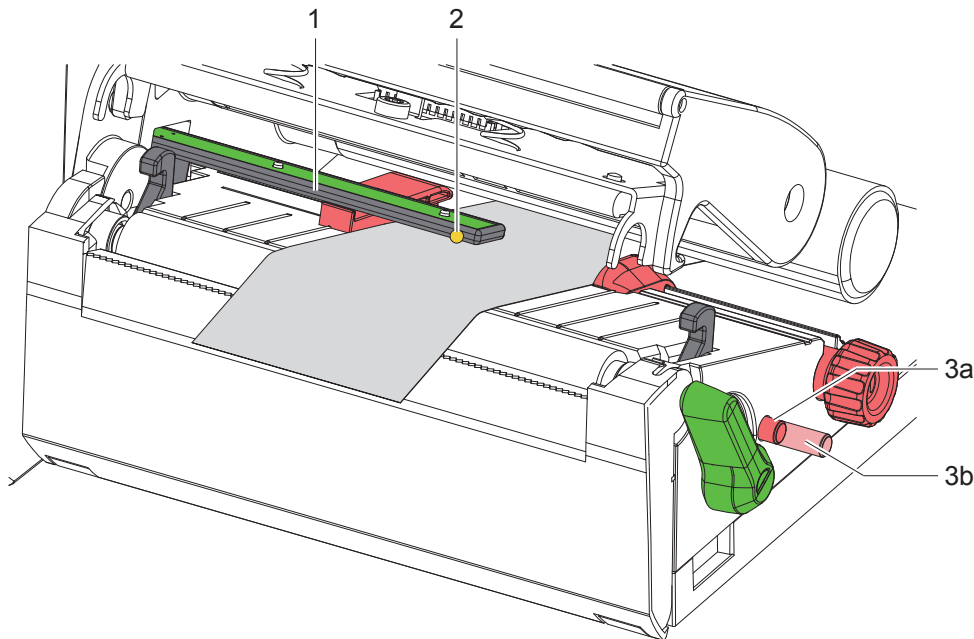

Figure 10 Adjusting the label sensor

The sensor position (2) is marked with a yellow LED in the sensor holder.

1. Open the printhead.
2. Release the label sensor (3) by pressing, so that it is extended (3b) ready to make an adjustment.
3. Position the sensor holder (1) by turning the knob (3) so that the sensor (2) can detect the front edge of the label in the direction of paper flow or the reflex or cut-out mark.
4. Return the label sensor adjuster knob by pushing it back in (3a)

**Note!**

It is important to ensure the label sensor adjustment knob is returned into the printer (3a), before closing the printhead.

4.3 Loading Transfer Ribbon

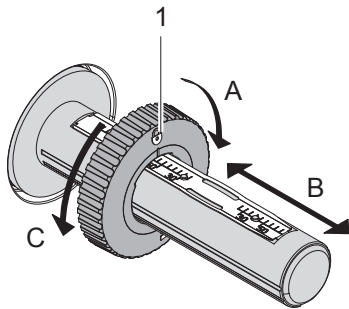

Figure 11 Guide Adjustment

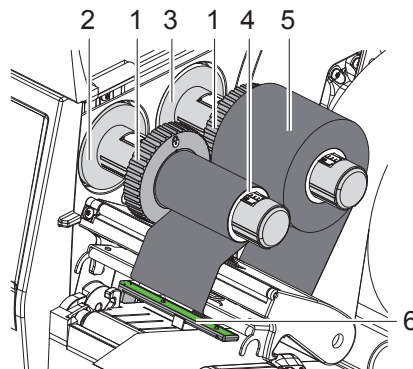

Figure 12 Loading Transfer Ribbon

1. Open the printhead.
2. Clean the printhead before loading the transfer ribbon (▷ 6.3 on page 18).
3. Set guide (1) on the ribbon supply hub to the correct transfer ribbon width (Figure 11):
 - Hold the hub and unlock the guide (1) by turning it in direction A.
 - Slide the guide in direction B and adjust the guide to the ribbon width using the scale.
 - Hold the hub and lock the guide by turning it in direction C.
4. Slide transfer ribbon roll (5) onto the ribbon supply hub (3) until it reaches the guide (1) so that the ink coating of the ribbon faces downward when being unwound.

**Note!**

To rewind the ribbon a ribbon core (4) is needed that must be at least equal in width to the supply ribbon.

► **When changing the transfer ribbon use the empty supply ribbon core for winding the next ribbon.**

5. Adjust the position of the guide on the take-up hub to the width of the ribbon core (4) and push ribbon core on the take-up hub (2).
6. Guide the transfer ribbon through the printing unit as shown in Figure 13.

**Attention!**

► **Guide transfer ribbon over the label sensor (6).**

7. Secure the starting end of transfer ribbon to the transfer ribbon core (4) with adhesive tape. The transfer ribbon take-up hub is turned counterclockwise.
8. Turn transfer ribbon take-up hub (2) counterclockwise to smooth out the feed path of the transfer ribbon.
9. Close the printhead.

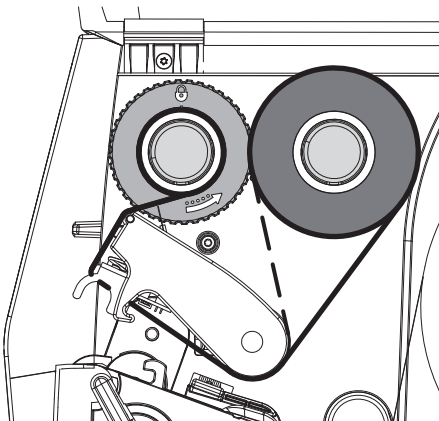

Figure 13 Transfer Ribbon Feed Path

4.4 Setting the Feed Path of the Transfer Ribbon

Transfer ribbon wrinkling can lead to print image errors. The transfer ribbon deflection bar (2) can be adjusted to prevent wrinkles.

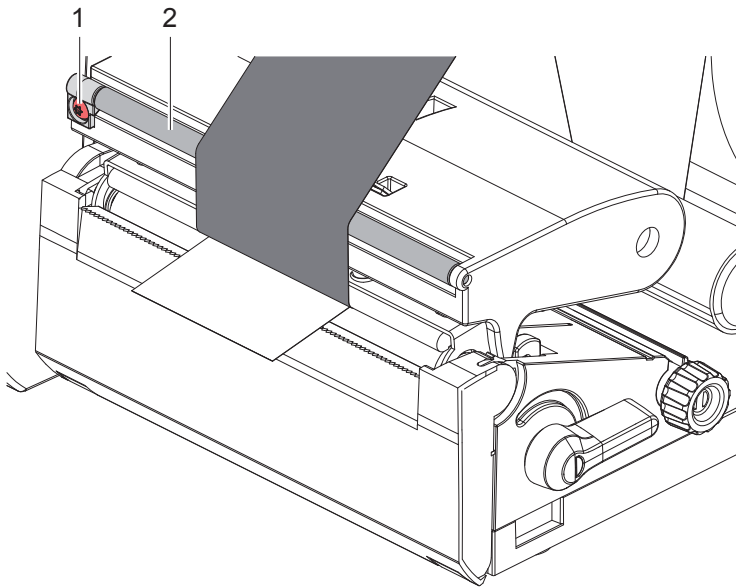

Figure 14 Setting the feed path of the transfer ribbon



Note!

The adjustment is best carried out during printing.

- ▶ Turn screw (1) with torx wrench TX10 and observe the behavior of the ribbon.
- By turning it clockwise the outer edge of the transfer ribbon is tightened.
- By turning it counterclockwise the inner edge of the transfer ribbon is tightened.

**Attention!**

Printhead damage is caused by improper handling!

- ▶ Do not touch the underside of the printhead with fingers or sharp objects.
- ▶ Ensure labels are clean.
- ▶ Ensure that the label surfaces are smooth. Rough labels act like emery paper and reduce the service life of the printhead.
- ▶ Print with the lowest possible printhead temperature.

The Printer is ready for operation when all connections are made and the transfer ribbon and labels are loaded.

5.1 Printing in Tear-off Mode

After printing, a label can be torn off manually using the tear off plate (2) Figure 15.

5.2 Printing in Cutting Mode

- * Cutter and Perforator units are available as an accessory. Please consult TE document TTDS-260 for all TE printer accessories.

6.1 Cleaning Information

**Danger!**

Risk of death via electric shock!

- ▶ **Disconnect the printer from the power supply before performing any maintenance work.**

The label printer requires very little maintenance.

It is important to clean the thermal printhead regularly. This guarantees a consistently good printed image and plays a major part in preventing premature wear of the printhead.

Otherwise, the maintenance is limited to monthly cleaning of the device.

**Attention!**

The printer can be damaged by aggressive cleansers.

Do not use abrasive cleaners or solvents for cleaning the external surfaces or modules.

- ▶ Remove dust and paper fluff from the print area with a soft brush or vacuum cleaner.

6.2 Cleaning the Print Roller

Accumulations of dirt on the print roller may impair the media transport and the print quality.

**Attention!**

Damage of the print roller.

- ▶ **Do not use sharp objects (knives, screwdrivers, etc.) to clean the print roller.**

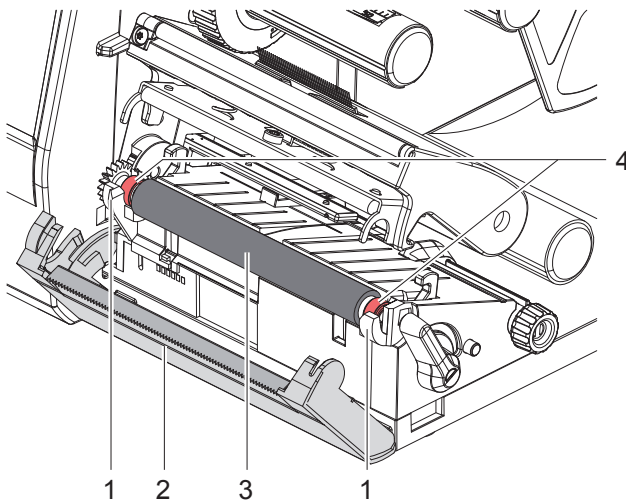

Figure 15 Print roller

1. Open the printhead.
2. Remove material and transfer ribbon from the printer.
3. Fold down the tear-off plate (2).
4. Lift the print roller (3) from its retainers (1).
5. Remove deposits with roller cleaner and a soft cloth, or replace it if the roller appears damaged.
6. Push roller with bearings (4) into the retainers (1) until they click into place.
7. Fold up the tear-off plate (2).

6.3 Cleaning the Printhead

Cleaning intervals: - every media roll change

Substances may accumulate on the printhead during printing and adversely affect printing, e.g. differences in contrast or vertical stripes.



Attention!

Printhead can be damaged!

Do not use sharp or hard objects to clean the printhead.

Do not touch protective glass layer of the printhead.



Caution!

Risk of injury from the hot printhead.

► **Ensure that the printhead has cooled down before starting cleaning.**

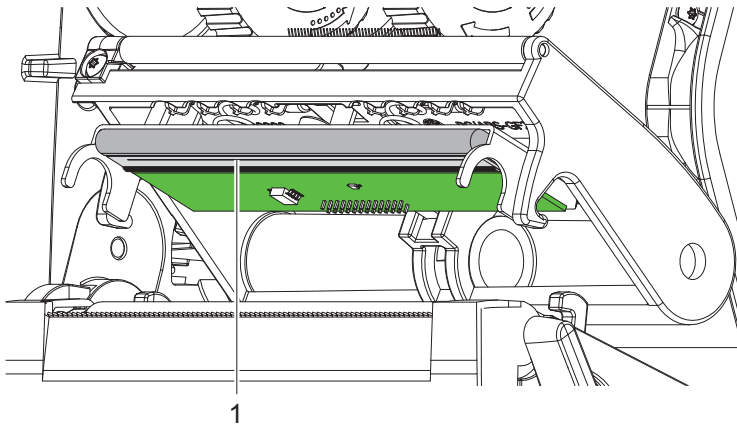

Figure 16 Heating line of the printhead

- Open the printhead.
- Remove material and transfer ribbon from the printer.
- Clean the printhead heating line (1) with Alcohol (IPA) and a soft cloth.
(For detailed information and advice please consult TE document 411-121037 Thermal Transfer printhead cleaning instructions.)
- Allow printhead to dry for 2–3 minutes before commencing printing.

7.1 Error Display

The appearance of an error will be shown on the display:

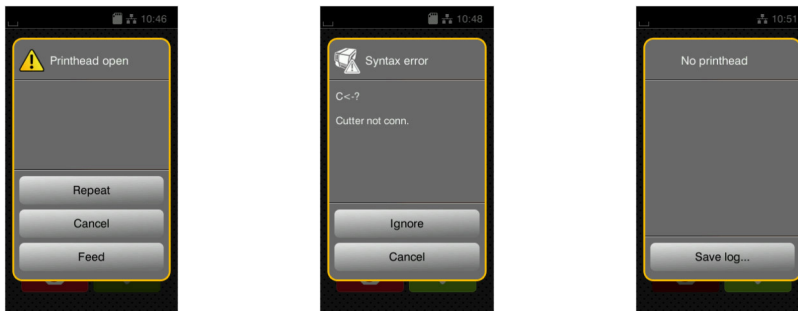

Figure 17 Error display

The error correction is dependent on the error type ▷ 7.2 on page 19.

The display offers the following solutions to continue printing.

<i>Repeat</i>	The print job will continue after clearing the error.
<i>Cancel</i>	The print job will be cancelled.
<i>Feed</i>	The paper feed will be synchronized. Following the print job can be continued.
<i>Ignore</i>	The error message will be ignored. The print job will be continued possibly with limited performance.
<i>Save log</i>	The error does not allow print operation. For detailed analysis several system files can be saved on an external memory.

Table 5 Button in the error display

7.2 Error Messages and Fault Correction

Error message	Cause	Remedy
<i>Barcode error</i>	Invalid barcode content, e.g. alphanumeric characters in a numerical barcode	Correct the barcode content.
<i>Barcode too big</i>	The barcode is too big for the allocated area of the label	Reduce the size of the barcode or move it.
<i>Buffer overflow</i>	The input buffer memory is full and the computer is still transmitting data.	Use data transmission via protocol (preferably RTS/CTS).
<i>Cutter blocked</i>	Cutter cannot return into its home position and stays in an undefined position	Switch off the printer. Remove material. Switch on the printer. Restart print job. Change material
	No cutter function	Switch the printer off and then on. If error recurs call service.
<i>Cutter jammed</i>	The cutter is unable to cut the labels but is able to return into its home position	Press <i>Cancel</i> Change material.
<i>Device not conn.</i>	Programming addresses a non-existent device	Either connect this device or correct the programming.
<i>File not found</i>	Requested file is not on the card	Check the contents of the card.
<i>Font not found</i>	Error with the selected download font	Cancel current print job, change font.
<i>Memory overflow</i>	Current print job contains too much information, e.g. selected font, large graphics	Cancel current print job. Reduce amount of data to be printed.
<i>Name exists</i>	Duplicate usage of field name in the direct programming	Correct programming

Error message	Cause	Remedy
<i>No label found</i>	There are labels missing on the label material	Press <i>Repeat</i> repeatedly until printer recognizes the next label on the material.
	The label format as set in the software does not correspond with the real label format	Cancel current print job. Change the label format set in the software. Restart print job.
	Printer is loaded with continuous paper, but the software is set on labels	Cancel current print job. Change the label format set in the software. Restart the print job.
<i>No label size</i>	The size of the label is not defined in the programming.	Check programming.
<i>Out of paper</i>	Out of label roll	Load labels.
	Error in the paper feed	Check paper feed.
<i>Out of ribbon</i>	Out of transfer ribbon	Load new transfer ribbon.
	Transfer ribbon melted/snapped during printing	Cancel current print job. Change the heat level via software. Clean the printhead ▷ 6.3 on page 18 Load transfer ribbon. Restart print job.
<i>Printhead open</i>	Printhead not locked	Lock printhead.
<i>Printhead too hot</i>	Printhead is overheated	After pausing the print job will be continued automatically. If the fault recurs repeatedly, reduce the heat level or the print speed via software.
<i>Read error</i>	Read error when reading from the memory card	Check data of the card. Backup data, reformat card.
<i>Remove ribbon</i>	Transfer ribbon is loaded although the printer is set to direct thermal printing	Set the printer in the configuration or in the software to transfer printing
<i>Ribbon ink side</i>	Identified ribbon unwinding direction does not match to the setup setting	Ribbon loaded incorrectly. Clean the printhead ▷ 6.3 on page 18. Load the ribbon correctly.
		Setting does not match to the used ribbon. Correct the setting.
<i>Syntax error</i>	Printer has received an unknown or invalid command from the computer.	Press <i>Ignore</i> to skip the command or press <i>Cancel</i> to cancel the print job.
<i>Unknown card</i>	Card not formatted, Type of card not supported	Format card, use different type of card.
<i>Voltage error</i>	Hardware error	Switch the printer off and then on. If error recurs contact TE Technical support. It is shown which voltage has failed. Please note.
<i>Write error</i>	Hardware error	Repeat the write process, reformat card.

Table 6 Error Messages and Fault Correction

7.3 Problem Solution

Problem	Cause	Remedy
Transfer ribbon creases	Transfer ribbon deflection not adjusted	Adjust the transfer ribbon deflection. ▷ 4.4 on page 15
	Transfer ribbon too wide	Use a transfer ribbon slightly wider than the width of label.
Print image has smears or voids	Printhead is dirty	Clean the printhead. ▷ 6.3 on page 18
	Temperature too high	Decrease temperature via software.
	Unsuitable combination of labels and transfer ribbon	Consult TE document 411-121005 Identification Printer Product Ribbon Matrix.
Printer does not stop after transfer ribbon runs out	Direct Thermal printing has been selected in the printer menu.	Change to thermal transfer printing.
Printer prints a sequence of characters instead of the label format	Printer is in <i>ASCII dump mode</i>	Cancel the <i>ASCII dump mode</i> .
Printer transports label media, but transfer ribbon does not move	Transfer ribbon incorrectly inserted.	Check and, if necessary, correct the transfer ribbon web and the orientation of the label side.
	Unsuitable combination of labels and transfer ribbon	Consult TE document 411-121005 Identification Printer Product Ribbon Matrix.
Printer only prints each second label	Setting of the size in the software is too large.	Change the size in the software.
Vertical white lines in the print image	Printhead is dirty	Clean the printhead. ▷ 6.3 on page 18
	Printhead is defective (failure of heat elements)	Change the printhead. Contact TE Technical Support
Horizontal white lines in the print image	Printer is used with the <i>backfeed > smart</i> in the cut or peel-off mode	Set the <i>backfeed > always</i> in the setup.
Print image is irregular, one side is lighter	Printhead is dirty	Clean the printhead. ▷ 6.3 on page 18

Table 7 Problem solution

8.1 Reference to the EU Declaration of Conformity

The printers of the T2212 series comply with the relevant fundamental regulations of the EU Rules for Safety and Health:

- Directive 2014/35/EU relating to electrical equipment designed for use within certain voltage limits
- Directive 2014/30/EU relating to electromagnetic compatibility
- Directive 2011/65/EU on the restriction of the use of certain hazardous substances in electrical and electronic equipment

EU Declaration of Conformity

For the current EU Declaration of Conformity please contact your local TE Connectivity Representative or use the following link to download

▷ [EU Declaration of Conformity](#)



8.2 FCC

NOTE : This equipment has been tested and found to comply with the limits for a Class A digital device, pursuant to Part 15 of the FCC Rules. These limits are designed to provide reasonable protection against harmful interference when the equipment is operated in a commercial environment. The equipment generates, uses, and can radiate radio frequency and, if not installed and used in accordance with the instruction manual, may cause harmful interference to radio communications. Operation of this equipment in a residential area is likely to cause harmful interference in which case the user may be required to correct the interference at his own expense.

C

Cleaning	
information	17
printhead	18
print roller	17
Connecting	8
Contents of delivery	8

D

Device overview	6
-----------------------	---

E

Environment	5
Errors	
correction	19
messages	19
types	19

I

Important information	4
Intended use	4

L

Lithium battery	5
Loading labels	12
Loading labels from a roll	12
Loading transfer ribbon	14

M

Margin stop	6
-------------------	---

P

Power supply	5
Printhead	
cleaning	18
damage	16
Print roller, cleaning	17
Problem solution	21

S

Safety instructions	5
Service work	5
Setting the ribbon feed path	14
Setting-up	8
Supply voltage	8
Switching on	8

T

Tear-off mode	16
---------------------	----

U

Unpacking	8
-----------------	---

V

Voltage	5
---------------	---

This page was left blank intentionally.