



DEUTSCH* DT 2 & 3pin Snap Cap Connector Series

1. INTRODUCTION

1.1. Purpose

This report summarizes the results of testing performed on DEUTSCH DT 2 & 3 pin snap cap connector system to determine conformance to the requirements of product specification 108-151009.

1.2. Scope

This report covers the electrical, mechanical, and environmental performance of the DEUTSCH DT 2 & 3 pin snap cap connector system. Testing for groups 1 – 3 was performed at the TE Connectivity Shanghai, CN Electrical Component Test Laboratory in 2017. This documentation is on file at TE Connectivity Shanghai, CN Electrical Component Test Laboratory. Testing for group 4 was performed at the TE Connectivity North Carolina, USA Test Laboratory. This documentation is on file at TE Connectivity North Carolina, USA Test Laboratory. All test files for these testing groups are listed in Figure 1.

Test Group	Test Report
1	501-1322633 (17-AUT-CN-0007)
2	
3	
4	TR 2302030

Figure 1

1.3. Conclusion

The DEUTSCH DT 2 & 3pin snap cap connector system products listed in Paragraph 1.4 conform to the electrical and environmental performance requirements given in product specification 108-151009.

1.4. Test Specimens

Test specimens were representative of normal production lots. Specimens identified with the part numbers given in Figure 2 were used for testing.

PART NUMBER	DEUTSCH PN	SIMILAR TO PN	DESCRIPTION	TEST GROUP
1-2303812-1	DT04-2P-TE31	DT04-2P-CE01	2pin Receptacle, Blk, E, Snap Cap	1-3
1-2303812-2	DT04-2P-TN31	DT04-2P-E003	2pin Receptacle, Blk, N, Snap Cap	
2-2303812-1	DT04-2P-TE81	DT04-2P-CE04	2pin Receptacle, Blk, E, X-Snap Cap	
2-2303812-2	DT04-2P-TN81	DT04-2P-E008	2pin Receptacle, Blk, N, X-Snap Cap	
1-2303813-1	DT04-3P-TE31	DT04-3P-CE01	3pin Receptacle, Blk, E, Snap Cap	
1-2303813-2	DT04-3P-TN31	DT04-3P-E003	3pin Receptacle, Blk, N, Snap Cap	
2-2303813-1	DT04-3P-TE81	DT04-3P-CE04	3pin Receptacle, Blk, E, X-Snap Cap	
2-2303813-2	DT04-3P-TN81	DT04-3P-E008	3pin Receptacle, Blk, N, X-Snap Cap	
1-2303815-1	DT06-2S-TE31	DT06-2S-CE01	2pin Plug, Blk, E, Snap Cap	
1-2303815-2	DT06-2S-TE31	DT06-2S-E003	2pin Plug, Blk, N, Snap Cap	
2-2303815-1	DT06-2S-TE81	DT06-2S-CE04	2pin Plug, Blk, E, X-Snap Cap	
2-2303815-2	DT06-2S-TN81	DT06-2S-E008	2pin Plug, Blk, N, X-Snap Cap	
1-2303816-1	DT06-3S-TE31	DT06-3S-CE01	3pin Plug, Blk, E, Snap Cap	
1-2303816-2	DT06-3S-TN31	DT06-3S-E003	3pin Plug, Blk, N, Snap Cap	
2-2303816-1	DT06-3S-TE81	DT06-3S-CE04	3pin Plug, Blk, E, X-Snap Cap	
2-2303816-2	DT06-3S-TN81	DT06-3S-E008	3pin Plug, Blk, N, X-Snap Cap	
2441202-1	DT06-2S-TE01	NA	2pin Plug, Gry, E	4
DT04-2P	DT04-2P	NA	2pin Receptacle, Gry, N	
1060-16-0122	1060-16-0122	NA	Size 16 S&F Pin, Nickel	1-4
1062-16-0122	1062-16-0122	NA	Size 16 S&F Socket, Nickel	
W2S-P012	W2S-P012	NA	2pin Plug Wedgelock, Green	4
W2P	W2P	NA	2pin Receptacle Wedgelock, Green	

Figure 2

1.5. Environmental Conditions

Unless otherwise stated, the following environmental conditions prevailed during testing:

Temperature: 15° to 35°C

Relative humidity: 25 to 75%

1.6. Qualification Test Sequence

TEST OR EXAMINATION	TEST GROUP (a)			
	1	2	3	4
	TEST SEQUENCE (b)			
Examination of Product	1,12	1,11	1,8	1,7
Insulation Resistance	2,10	2		2,4,6
Connection Resistance	3,6,8	3,10		
Mating Forces		5	3	
Un-mating Forces		6	4	
Maintenance Aging			2	
Durability		7	5	
Terminal Retention in Connector			6	
Connector Retention			7	
Thermal Shock	4	8		3
Temperature Life		4		
Vibration	5			
Drop	7	9		
Water Immersion	9			5
Fluid Immersion	11			

(a) Specimens were prepared in accordance production drawings and were selected at random from current production.

- Group 1 specimens consisted of 3 samples each with DEUTSCH stamped and formed terminals size 16 nickel pins and sockets with 16 GXL wire.
 - 2-pin N, Cap, 2-pin E, Cap, 2-pin N, X-Cap, 2-pin E, X-Cap
 - 3-pin N, Cap, 3-pin E, Cap, 3-pin N, X-Cap, 3-pin E, X-Cap
- Group 2 specimens consisted of 2 samples each with DEUTSCH stamped and formed terminals size 16 nickel pins and sockets with 16 GXL wire.
 - 2-pin N, Cap, 2-pin E, Cap, 2-pin N, X-Cap, 2-pin E, X-Cap
 - 3-pin N, Cap, 3-pin E, Cap, 3-pin N, X-Cap, 3-pin E, X-Cap
- Group 3 specimens consisted of 2 samples each with DEUTSCH stamped and formed terminals size 16 nickel pins and sockets with 16 GXL wire.
 - 2-pin N, Cap, 2-pin E, Cap, 2-pin N, X-Cap, 2-pin E, X-Cap
 - 3-pin N, Cap, 3-pin E, Cap, 3-pin N, X-Cap, 3-pin E, X-Cap
- Group 4 specimens consisted of 6 samples each with DEUTSCH stamped and formed terminals size 16 nickel pins and sockets with 16 GXL wire.

(b) Numbers indicate sequence that tests were performed.

Figure 3

2. TEST METHODS AND RESULTS

2.1. Examination of Product (Group 1-4)

A. Procedure: SAE J2030_201506

B. Method: Conduct a visual examination for identification of product, torn seals, cracked plastic, etc.

C. Requirement: The connectors shall be correctly constructed, marked, and show good quality and workmanship. Connector after conditioning shall not show signs of damage or any detectable loss of function.

D. Result: **PASSED.**



2.2. Insulation Resistance (Group 1,2,4)

A. Procedure: SAE J2030_201506

B. Method: Using a 1000 VDC megohmmeter check the insulation resistance between each contact to each adjacent contact

C. Requirement: > 20 MΩ

D. Result: **PASSED.**



2.3. Connection Resistance (Group 1,2)

A. Procedure: SAE J2030_201506

B. Method: The resistance of a cable equal in length to that of the two measuring points shall be subtracted from the measured values. The cable used shall be from the same batch of cable as used for the connector wiring.

C. Requirement: Measurements shall be taken after thermal equilibrium at 15A. Voltage drops shall not exceed 100mV.

D. Result: **PASSED.**

2.4. Mating Force (Group 2,3)

A. Procedure: SAE J2030_201506

B. Method: The maximum required force to mate the plug and receptacle pair and engage the latching mechanism.

C. Requirement: $F \leq 135\text{N}$

D. Result: **PASSED.**

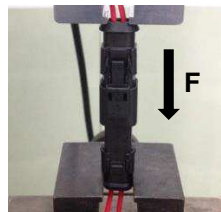

2.5. Un-Mating Force (Group 2,3)

A. Procedure: SAE J2030_201506

B. Method: The maximum force required to separate the plug and receptacle with the latch mechanism fully disengaged.

C. Requirement: $F \leq 135\text{N}$

D. Result: **PASSED.**

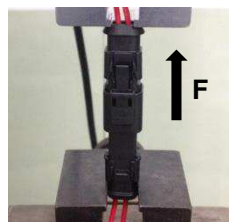

2.6. Maintenance Aging (Group 3)

- A. Procedure: SAE J2030_201506
- B. Method: Subject at least 10% of the cavities to 10 cycles of inserting and removing its respective contact. The 10th cycle shall include any disassembly required to remove the contacts. The connectors shall be mated and unmated during each cycle.
- C. Requirement: There shall be no visible change or damage to the contact cavity
- D. Result: **PASSED.**

2.7. Durability (Group 2,3)

- A. Procedure: SAE J2030_201506
- B. Method: The connector shall be mated and unmated for a total of 50 complete cycles.
- C. Requirement: No evidence of damage to the contacts, contact plating, connector housing or seals which may be detrimental to reliable connector performance.
- D. Result: **PASSED.**

2.8. Terminal Retention in Connector (Group 3)

- A. Procedure: SAE J2030_201506
- B. Method: The contacts shall be subjected to a direct pull of 110N for 1 minute. The pull is to be exerted on the conductor by means of a tension-testing machine or equivalent to prevent sudden or jerking force during test. The terminal shall maintain its original position in the connector throughout the test. The secondary-locking device is needed.
- C. Requirement: The contact shall remain in place.
- D. Result: **PASSED.**

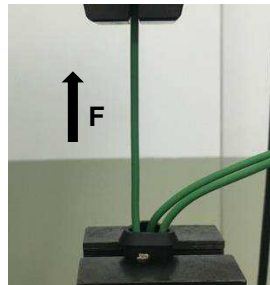

2.9. Connector Retention (Group 3)

- A. Procedure: SAE J2030_201506
- B. Method: Apply a pulling force to the wire bundle of the mated connector. The load shall be applied for 30 seconds
- C. Requirement: 2pin: 222N, 3pin: 300N.
- D. Result: **PASSED.**

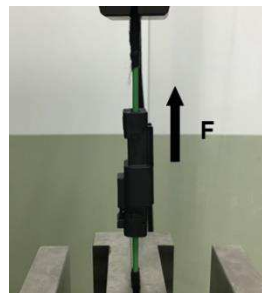

2.10. Thermal Shock (Group 1,2,4)

- A. Procedure: SAE J2030_201506
- B. Method: Test samples were subjected to 10 cycles. One cycle consisted of a soak time at -55°C, then transitioned within 2 minutes to an ambient temperature of +125°C with a soak time, and then transition back to -55°C within 2 minutes. The soak times were established as the time necessary to bring the internal connector temperature on test to within 5°C of each of the ambient temperatures.
- C. Requirement: No evidence of cracking, chipping, or other damage detrimental to the normal operation of the connector.
- D. Result: **PASSED.**

2.11. Temperature Life (Group 2)

- A. Procedure: SAE J2030_201506
- B. Method: 125°C for 1000 hours
- C. Requirement: No evidence of cracking, chipping, or other damage detrimental to the normal operation of the connector.
- D. Result: **PASSED.**

2.12. Vibration (Group 1)

- A. Procedure: SAE J2030_201506
- B. Method:
 - Sine Sweep: 10 to 2000 Hz
 - Max Acceleration: 20 G
 - Time Per Axis: 8 hours
 - Test Duration: 24 hours
 - Test Current: 13A first 3 hours each axis

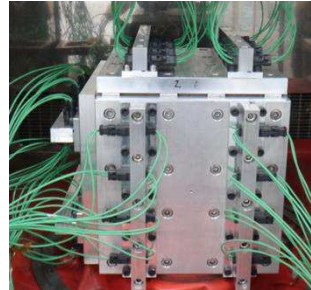

- C. Requirement: No defects, cracks, and no discontinuity greater than $10\Omega >1 \mu s$ during the last hour of each axis.

D. Result: **PASSED.**

2.13. Drop (Group 1,2)

- A. Procedure: SAE J2030_201506
- B. Method: The free end of the cord or cable, which shall be 1500 mm, shall be fixed to a wall at a height of 750 mm above a concrete floor. The specimen shall be held so that the cord or cable is horizontal and allowed to fall to a concrete floor eight times. Rotate the specimens through approximately 45° at it fixing each time.
- C. Requirement: There shall be no evidence of cracking, distortion or detrimental damage to the connector following the test. Small chips and dents that do not adversely affect the connector shall be disregarded.
- D. Result: **PASSED.**

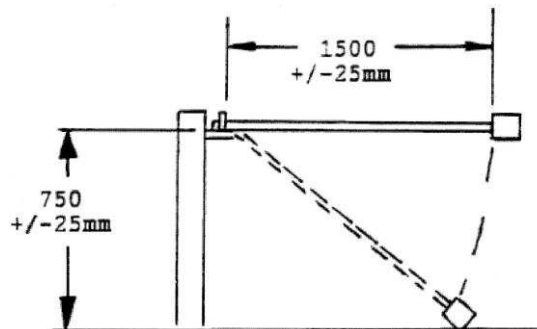

2.14. Water Immersion (Group 1,4)

- A. Procedure: SAE J2030_201506
- B. Method: The wired mated connectors shall be placed in an oven at +125°C for 1 hour then immediately be placed in water with a 5% salt in weight content and 0.1 g/L wetting agent, to a depth of 1 meter for 4 hours. Water temperature is to be 23°C. The ends of the cable are to be sealed during this test.
- C. Requirement: Must meet insulation resistance and visually inspect for moisture inside the connector.
- D. Result: **PASSED.**

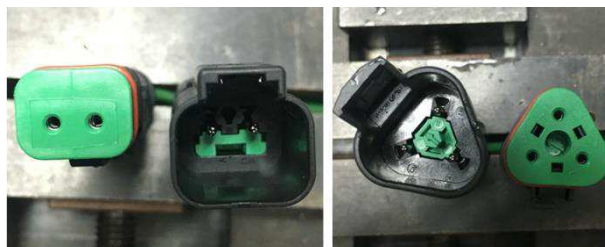

2.15. Fluid Immersion (Group 1)

A. Procedure: SAE J2030_201506

B. Method: Subject each connector to one fluid only in the cabled and mated condition. Submerge the mated connector in fluid per Figure 12-18 at the specified temperature ± 3 °C for 5 minutes, then remove and allow to air dry for 24 h. This completes one cycle. Each connector is to be subjected to a total of five cycles. Inspect for damage after the test.

C. Requirement: No evidence of cracking, distortion, or detrimental damage to the connector.

D. Result: **PASSED.**



Motor oil IRM-902 +85°C



Brake fluid SAE RM66-04 +85°C



Diesel fuel RM-903/T-Xylene +60°C



Antifreeze mixture Fluid 104 +85°C



Roundup Original +23°C



Gear oil 90wt-Mobil ATF +85°C

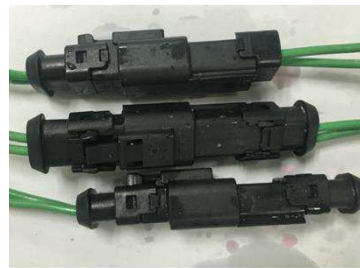

Aqueous Urea- Ad-Blue +23°C

3. REVISION HISTORY

Rev Ltr	Brief Description of Change	Date	Dwn	Apvd
A	Initial Release	27-Mar-2020	DM	DM
B	Page 1. Added to the Scope. Page 1. Added new information to the Test Group Table. Page 2. Added new information to the Test Specimen Table. Page 2. Added new data to Test Sequence Table. Page 3. Added note to the Qualification Test Sequence Section. Page 4. Added Group 4 to Examination of Product. Page 4. Added Group 4 to Insulation Resistance. Page 5. Added Group 4 to Thermal Shock. Page 6. Added Group 4 to Water Immersion.	19APR2023	AP	IG