

Impact Interconnect Systems

1. INTRODUCTION

1.1. Purpose

Testing was performed on the Tyco Electronics Impact Interconnect Systems to determine their conformance to the requirements of Product Specification 108-2351 Revision A.

1.2. Scope

This report covers the electrical, mechanical, and environmental performance of the Impact Interconnect Systems. Testing was performed at the Harrisburg Electrical Components Test Laboratory between 19Nov10 and 25Feb11. The test file number for this testing is EA20101012T. This documentation is on file at and available from the Harrisburg Electrical Components Test Laboratory.

1.3. Conclusion

The Impact Interconnect Systems listed in paragraph 1.5., conformed to the electrical, mechanical, and environmental performance requirements of Product Specification 108-2351 Revision H1.

1.4. Product Description

The Impact Interconnect System consists of modular groupings of broad-edge coupled signals with optional integrated guidance. These connectors are two-piece devices, which connect two Printed Circuit Boards (PCBs). The right angle receptacle connectors (daughtercard) and header pin connectors (backplane) are through-hole devices with Eye-of-the-Needle (EON) compliant pin terminals.

1.5. Test Specimens

Test specimens were representative of normal production lots. Specimens identified with the following part numbers were used for test:

Test Group	Quantity	Part Number	Description
1,2,3,4,5,6	53	2007716-1	4 pair, daughtercard 10 column, right guided, signal module
1,2,3,4,5,6,7	60	2007815-2	4 pair, 10 column, header right guided, left end wall signal module
1,2,3,4,5	38	60-1042769-1	4 pair, 10 column backplane PCB
1,2,3,4,5	38	60-1042770-1	4 pair, 10 column daughtercard PCB
4,7	10	60-1042772-1	4 pair, 10 column daughtercard PCB wired for vibration and EON LLCR
4	5	60-1042772-1	4 pair, 10 column daughtercard PCB wired for vibration and EON LLCR

Figure 1

1.6. Environmental Conditions

Unless otherwise stated, the following environmental conditions prevailed during testing:

- Temperature: 15 to 35°C
- Relative Humidity: 20 to 80%

1.7. Qualification Test Sequence

Test or Examination	Test Group (a)						
	1	2	3	4(b)	5	6(c)	7
	Test Sequence (e)						
Initial examination of product	2	1	1	1	1	1	1
LLCR	4,6	3,5	2,5,7,9	2,4,7,9,11	2,4,6,8,10,12,14,16,18		
Insulation resistance						2,6	
Withstanding voltage						3,7	
Compliant pin interface resistance							3,6
Sinusoidal vibration				6			
Mechanical shock				8			
Durability			3(f),8(f)	3(f),10(f)	5(g),17(g)		
Mating force	3,8	2,7					
Unmating force	7	6					
Compliant pin insertion force	1						2,5(d)
Compliant pin retention force							4,7
Minute/thermal disturbance					15		
Thermal shock		4				4	
Humidity/temperature cycling			6			5	
Temperature life	5				3		
Mixed flowing gas (h)					7,9,11,13		
Dust			4	5			
Final examination of product	9	8	10	12	19	8	8(h)

NOTE

- (a) See paragraph 1.5.
- (b) Separate specimens must be run for LLCR and discontinuity monitoring.
- (c) This test group not mounted on PCBs.
- (d) Remove and replace specimens on PCB 1 time.
- (e) Numbers indicate sequence in which tests are performed.
- (f) 100 cycles only.
- (g) 98 cycles only.
- (h) Cross section compliant pin joints (initial and reworked connectors).

Figure 2

2. SUMMARY OF TESTING

2.1. Initial Examination of Product - All Test Groups

All specimens submitted for testing were representative of normal production lots. A Certificate of Conformance (C of C) was issued by Product Assurance. Specimens were visually examined and no evidence of physical damage detrimental to product performance was observed.

2.2. Low Level Contact Resistance (LLCR) - Test Groups 1, 2, 3, 4 and 5

All LLCR measurements, taken at 100 milliamperes maximum and 20 millivolts maximum open circuit voltage had a change in resistance (ΔR) of less than 10 milliohms after testing.

NOTE *There are 12 different electrical lengths in each connector which accounts for the variation between the minimum and maximum values in initial LLCR readings.*

Condition	Initial (R)	After Temperature Life (ΔR)	Condition	Initial (R)	After Thermal Shock (ΔR)
Test Group 1			Test Group 2		
Minimum	7.36	-0.78	Minimum	7.46	-2.13
Maximum	22.47	3.90	Maximum	20.87	2.22
Average	13.60	0.31	Average	13.85	0.35
Standard Deviation	3.89	0.46	Standard Deviation	3.93	0.46
Nr/Nv	1200/1200	1200/1200	Nr/Nv	600/600	600/600

Condition	Initial (R)	After Dust (ΔR)	After Humidity/temperature Cycling (ΔR)	After 2 nd Durability (ΔR)
Test Group 3				
Minimum	7.74	-3.65	-3.81	-3.87
Maximum	21.64	-0.02	1.85	2.71
Average	14.03	-0.67	-0.51	0.46
Standard Deviation	3.92	0.41	0.46	0.56
Nr/Nv	600/600	600/600	600/600	600/600

Condition	Initial (R)	After 1 st Durability (ΔR)	After Vibration (ΔR)	After Mechanical Shock (ΔR)	After 2 nd Durability
Test Group 4					
Minimum	7.58	-2.93	-3.86	-3.61	-3.81
Maximum	22.08	1.82	3.02	1.27	0.15
Average	13.99	-0.30	-0.66	-0.56	-0.88
Standard Deviation	3.93	0.40	0.43	0.43	0.42
Nr/Nv	600/600	600/600	600/600	600/600	600/600

NOTE *All values in milliohms.*

Figure 3 (continued)

Condition	Initial (R)	After Temperature Life (ΔR)	After 1 st Durability (ΔR)	After 5 Days MFG (ΔR)	After 10 Days MFG (ΔR)	After 15 Days MFG (ΔR)	After 20 Days MFG (ΔR)	After Minute Disturbance (ΔR)	After 2 nd Durability (ΔR)
Test Group 5									
Minimum	7.42	-0.96	-1.16	-2.43	-2.97	-2.94	-2.78	-2.82	-2.77
Maximum	22.56	6.36	9.09	4.25	6.27	6.46	9.56	8.02	9.79
Average	13.92	0.57	1.04	0.33	0.31	0.07	0.12	0.21	1.42
Standard Deviation	3.92	0.75	1.30	0.56	0.58	0.51	0.58	0.60	1.59
Nr/Nv	1200/1200	1200/1200	1200/1200	1200/1200	1200/1200	1200/1200	1200/1200	1200/1200	1200/1200

NOTE

All values in milliohms.

Figure 3 (end)

2.3. Insulation Resistance - Test Group 4

All insulation resistance measurements were greater than 1000 megohms.

2.4. Withstanding Voltage - Test Group 4

No dielectric breakdown, flashover or leakage exceeding 5 milliohms occurred.

2.5. Compliant Pin Interface Resistance - Test Group 7

All compliant pin interface resistance measurements, taken at 100 milliamperes maximum and 20 millivolts maximum open circuit voltage were less than 1 milliohm.

Condition	Initial	After Rework
Minimum	0.098	0.016
Maximum	0.259	0.158
Average	0.170	0.084
Standard Deviation	0.036	0.041
NR/Nv	50/50	50/50

NOTE

All values in milliohms.

Figure 4

2.6. Sinusoidal Vibration - Test Group 4

No discontinuities were detected during vibration testing. Following vibration testing, no cracks, breaks, or loose parts on the specimens were visible.

2.7. Mechanical Shock - Test Group 4

No discontinuities were detected during mechanical shock testing. Following mechanical shock testing, no cracks, breaks, or loose parts on the specimens were visible.

2.8. Durability - Test Groups 3, 4 and 5

No evidence of physical damage was visible as a result of mating and unmating the specimens for a total of 200 times at a maximum rate of 500 cycles per hour.

2.9. Mating Force - Test Groups 1 and 2

All mating force measurements were less than 35 grams average per pin.

2.10. Unmating Force - Test Group 1

All unmating force measurements were greater than 15 grams average per pin.

2.11. Compliant Pin Insertion Force - Test Groups 1 and 7

All compliant pin insertion force measurements were less than 26.7 N for headers and 17.8 N [4 lbf] for receptacles.

2.12. Compliant Pin Retention Force - Test Group 7

All compliant pin retention force measurements were greater than 3.6 N for both headers and receptacles.

2.13. Minute/thermal Disturbance - Test Group 5

No evidence of physical damage was visible as a result of exposure to a minute disturbance.

2.14. Thermal Shock - Test Group 4

No evidence of physical damage was visible as a result of thermal shock testing.

2.15. Humidity/temperature Cycling - Test Group 4

No evidence of physical damage was visible as a result of humidity/temperature cycling.

2.16. Temperature Life - Test Group 2

No evidence of physical damage was visible as a result of temperature life testing.

2.17. Mixed Flowing Gas - Test Group 3

No evidence of physical damage was visible as a result of exposure to the pollutants of mixed flowing gas.

2.18. Final Examination of Product - All Test Groups

Specimens were visually examined and no evidence of physical damage detrimental to product performance was observed.

3. TEST METHODS

3.1. Initial Examination of Product

A C of C was issued stating that all specimens in this test package were produced, inspected, and accepted as conforming to product drawing requirements, and were manufactured using the same core manufacturing processes and technologies as production parts.

3.2. LLCR

LLCR measurements were made using a 4 terminal measuring technique (Figure 5). The test current was maintained at 100 milliamperes maximum with a 20 millivolt maximum open circuit voltage.

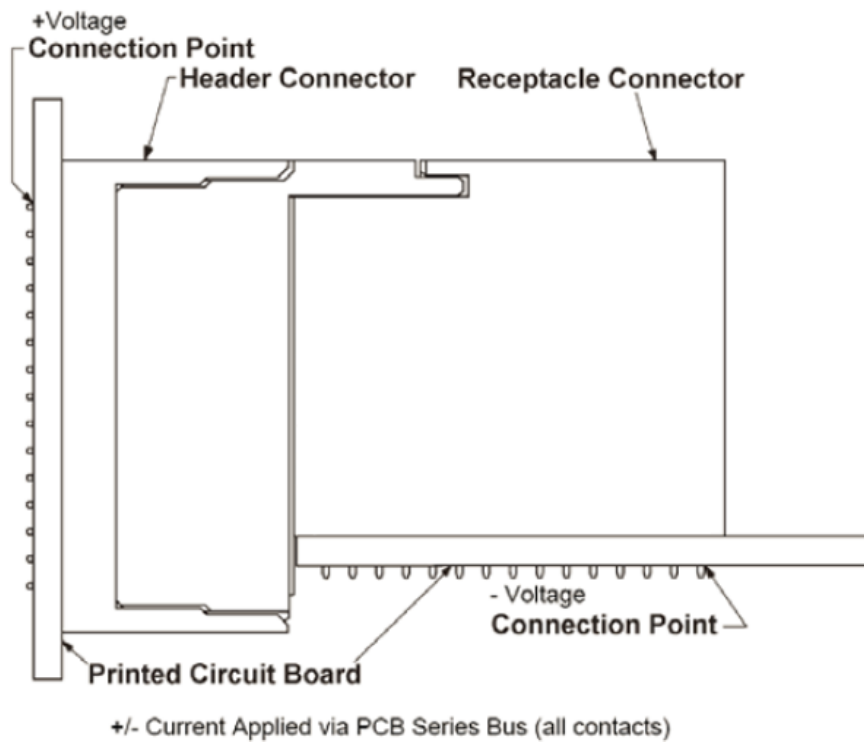

Figure 5
LLCR Measurement Points

3.3. Insulation Resistance

Insulation resistance was measured between adjacent contacts of unmated specimens. A test voltage of 500 volts DC was applied for 2 minutes before the resistance was measured. Each row was bussed together to combine all contacts in that row. Each row was tested to its adjacent row in order to test all contacts in all rows at the same time (Figure 6).

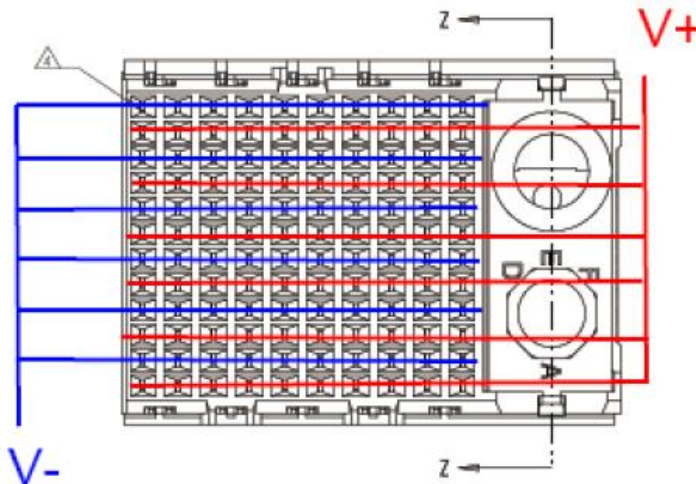

Figure 6
Insulation Resistance and Withstanding Voltage Measurement Points

3.4. Withstanding Voltage

A test potential of 500 volts AC was applied between adjacent contacts of unmated specimens for 1 minute and then returned to zero. Each row was bussed together to combine all contacts in that row. Each row was tested to its adjacent row in order to test all contacts in all rows at the same time (Figure 6).

3.5. Compliant Pin Interface Resistance

Compliant pin interface resistance measurements were made using a 4 terminal measuring technique (Figure 7). The test current was maintained at 100 milliamperes maximum with a 20 millivolt maximum open circuit voltage.

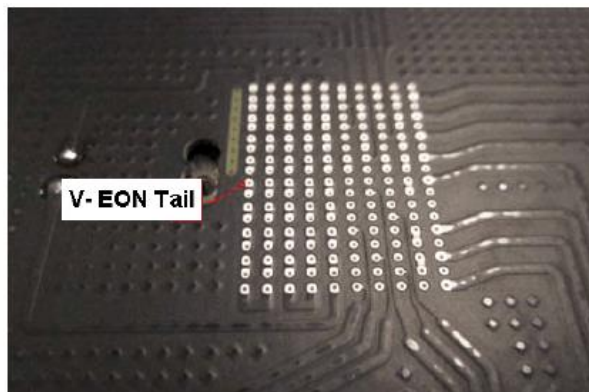
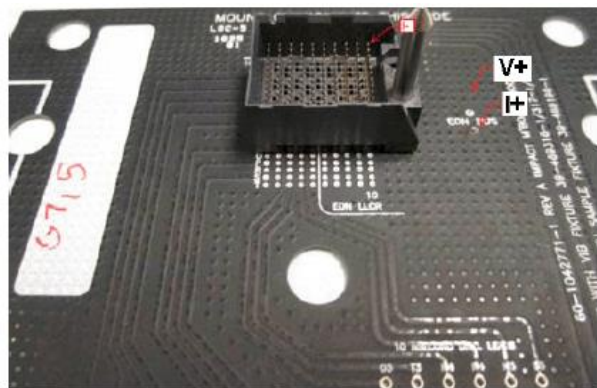

Figure 7
Compliant Pin Interface Resistance Measurement Points

3.6. Sinusoidal Vibration

Mated specimens were subjected to sinusoidal vibration, having a simple harmonic motion with an amplitude of 1.5 mm [0.06 in] peak-to-peak, or 10 G peak. The vibration frequency was varied uniformly between the limits of 10 and 500 Hz and returned to 10 Hz in 1 minute. This cycle was performed for 3 hours in each of 3 mutually perpendicular planes. Specimens were monitored for discontinuities of 10 nanoseconds or greater using a current of 100 milliamperes DC.

3.7. Mechanical Shock, Half-sine

Mated specimens were subjected to a mechanical shock test having a half-sine waveform of 30 gravity units (g peak) and a duration of 11 milliseconds. Three shocks in each direction were applied along the 3 mutually perpendicular planes for a total of 18 shocks. Specimens were monitored for discontinuities of 10 nanoseconds or greater using a current of 100 milliamperes DC.

3.8. Durability

Specimens in test group 3 were cycled 100 times during steps 3 and 8, specimens in test group 4 were cycled 100 times during steps 3 and 10, specimens in test group 5 were cycled 98 times during steps 5 and 17 at a maximum rate of 500 cycles per hour.

3.9. Mating Force

The force required to mate individual specimens was measured using a tensile/compression device with a free floating fixture and a rate of travel of 6.35 mm per minute. The maximum average force per contact was calculated.

3.10. Unmating Force

The force required to unmate individual specimens was measured using a tensile/compression device with a free floating fixture and a rate of travel of 6.35 mm per minute. The minimum average force per contact was calculated.

3.11. Compliant Pin Insertion Force

The force required to insert the specimens into the PCB was measured using a tensile/compression device with a free floating fixture and a rate of travel of 5.08 mm per minute.

3.12. Compliant Pin Retention Force

The force required to remove the specimens from the PCB was measured using a tensile/compression device with a free floating fixture and a rate of travel of 5.08 mm per minute.

3.13. Minute/thermal Disturbance

Mated specimens were subjected to 10 cycles of thermal disturbance between 15 and 85°C. Dwells were until specimens were acclimated to the temperature extremes with an approximate 10°C per minute transition time between temperatures.

3.14. Thermal Shock

Mated specimens were subjected to 5 cycles of thermal shock with each cycle consisting of 30 minute dwells at -55 and 85°C with 1 minute transition between temperatures.

3.15. Humidity/temperature Cycling

Mated specimens were exposed to 500 hours (20.83 cycles) of humidity-temperature cycling. Each cycle lasted 24 hours and consisted of cycling the temperature between 25°C and 65°C twice while maintaining high humidity. See the profile in (Figure 8).

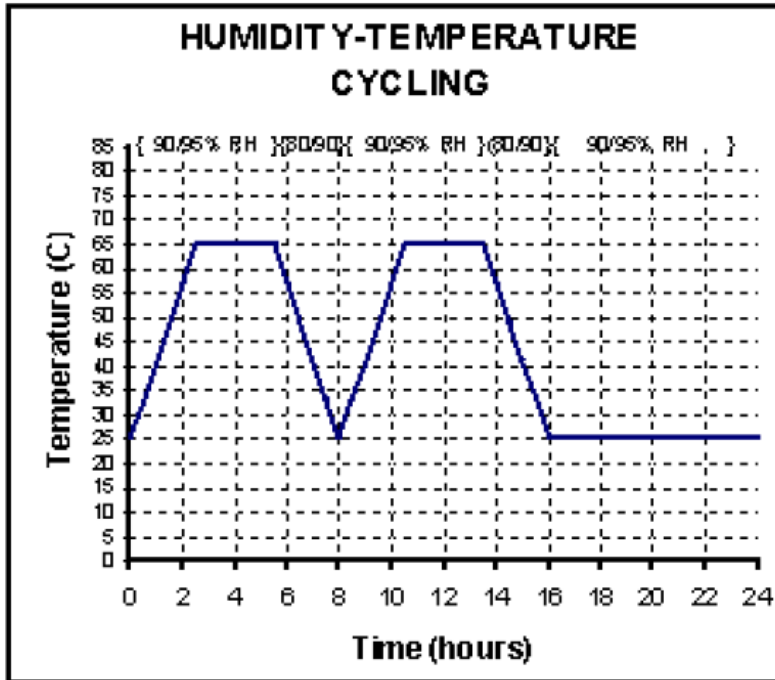

Figure 8
Typical Humidity/temperature Cycling Profile

3.16. Temperature Life

Mated specimens were exposed to a temperature of 85°C for 300 hours.

3.17. Mixed Flowing Gas, Class IIA

Mated specimens were exposed for 20 days to a mixed flowing gas Class IIA exposure. Class IIA exposure is defined as a temperature of 30°C and a relative humidity of 75% with the pollutants of Cl₂ at 10 ppb, NO₂ at 200 ppb, H₂S at 10 ppb and SO₂ at 100 ppb.

3.18. Final Examination of Product

Specimens were visually examined for evidence of physical damage detrimental to product performance.