



# INSTALLATION INSTRUCTIONS

EPP-2016-6/24

## Switchgear/Transformer Termination Dry Version for Polymeric Cables with Wire Shield Plug-In Unit

$U_m = 72.5 \text{ kV}$

TE's Raychem Cable Accessories

## PHVX

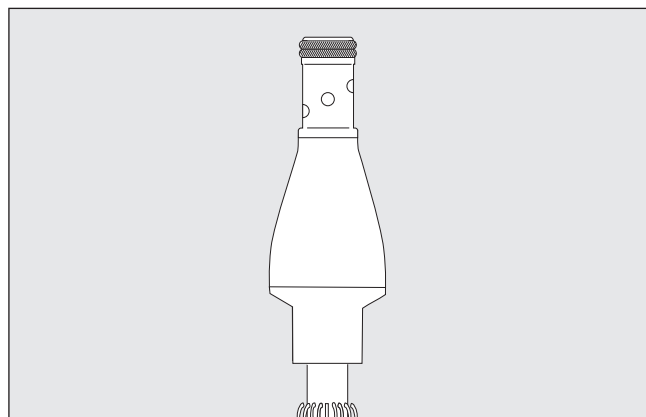

Please dispose of all waste according to environmental regulations.



For more information: [te.com/energy](https://te.com/energy)

**Tyco Electronics Raychem GmbH**

a TE Connectivity Ltd. Company

Finsinger Feld 1

85521 Ottobrunn/Munich, Germany

Tel: +49-89-6089-0

Fax: +49-89-6096-345

The Information contained in these installation instructions is for use only by installers trained to make electrical power installations and is intended to describe the correct method of installation for this product. However, TE Connectivity has no control over the field conditions which influence product installation.

It is the user's responsibility to determine the suitability of the installation method in the user's field conditions.

TE Connectivity's only obligations are those in TE Connectivity's standard Conditions of Sale for this product and in no case will TE Connectivity be liable for any other incidental, indirect or consequential damages arising from the use or misuse of the products.

Raychem, TE, TE Connectivity and TE connectivity (logo) are trademarks. © 2024 TE Connectivity. All Rights Reserved.

# General Instructions

## Before Starting

- Check the kit label and the title of the installation instructions to prove that the cable accessory you are going to use matches the cable.
- Make sure the cable is properly sealed.
- Make sure the cable is in the final installation position.
- Make sure the cable is straight at the jointing position.
- Check the position of the cables to be in alignment to the final position of the accessories.
- Make sure the joint bay/installation area provides adequate space for the cable components to be parked on either cable for later use during the installation.
- The joint bay/Installation area must be kept clean and dry during installation. For outdoor installation use tent or other appropriate shelter.
- Carefully read and follow the steps in the installation instructions. Components or working steps may have been changed/improved since you last installed this product.
- All tools, PPE and apparatus used must be kept clean during the installation.
- Obey relevant and local security and safety rules during the installation.

## Shrinking Heat-Shrink Tubing

- Use a propane (preferred) or butane gas torch.
- Ensure the torch is always used in a well-ventilated environment.
- Adjust the torch to obtain a soft blue flame with a yellow tip. Pencil-like blue flames should be avoided.
- Keep the torch aimed in the shrink direction to preheat the material.
- Keep the flame moving continuously to avoid scorching the material.
- Clean and degrease all parts that will come into contact with adhesives.
- If a solvent is used follow the manufacturer's handling instructions.
- Start shrinking the tubing at the position recommended in the instructions.
- Ensure that the tubing is shrunk smoothly all around before continuing along the cable.
- Tubing should be smooth and wrinkle free with inner components clearly defined.

## Stripping the Cable

Use appropriate stripping tools for smooth and even insulation diameter.

Adjust the stripping tool to the thickness of the semi-conductive layer. Avoid removing too much of the insulation. Polish the stripped surface by hand using the supplied abrasive paper beginning with the lowest grid size, or by an appropriate sanding machine and abrasive paper and grades. The surface of the insulation must be even and free of all traces of conductive material.

## Cables with Segmented Conductors

All cut back dimensions and information given in this instructions document refer to cables with non-segmented conductors only. In case of cables with segmented conductors, all insulation or conductive materials have to be removed from the conductor. If the removal of these materials require a longer cut back of the cable insulation, this length needs to be added to the cable cut back dimensions mentioned in the instructions.

### **NOTE**

**Special instructions for segmented conductors are available on request.**

## Installation of the Epoxy Insulator into the Switchgear/Transformer Housing

The epoxy insulator (5) should be installed under supervision of the switchgear/transformer manufacturer.

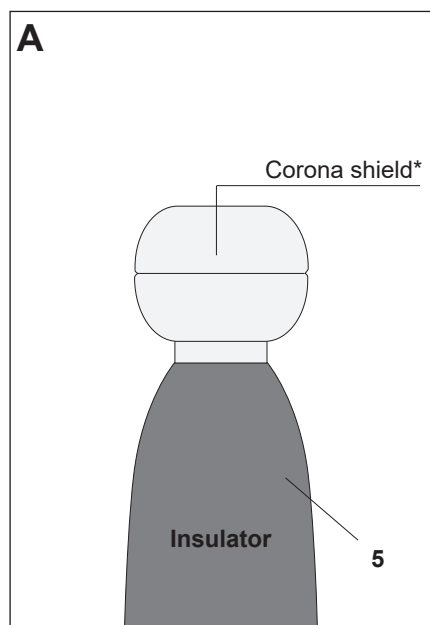

Bolt the lower part of the corona shield to the insulator electrode. Apply the top part of the corona shield.

\*Corona shield for transformer termination only (not for switchgear).

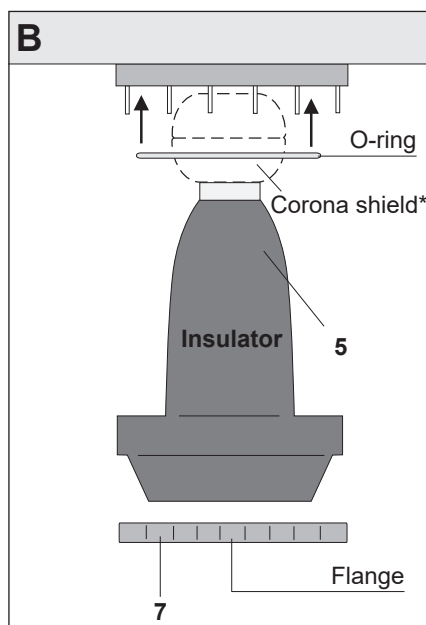

Put the O-ring (supplied by the switchgear/transformer manufacturer) into the sealing groove of the switchgear. Clean and degrease the epoxy insulator (5). Keep it free from dust and dirt.

\*Corona shield for transformer termination only (not for switchgear).

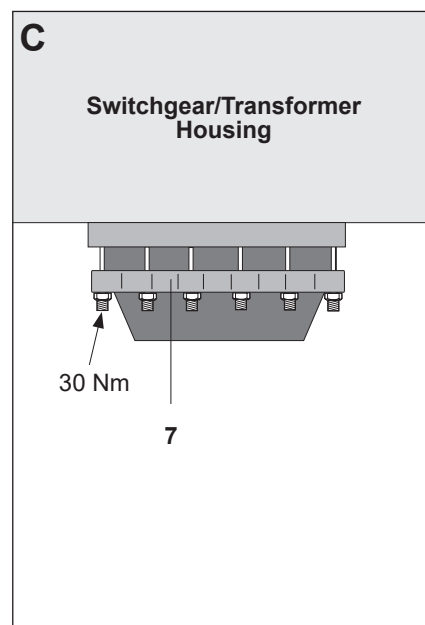

Insert the epoxy insulator (5) into the switchgear/transformer housing. Apply the flange (7). Bolt the flange evenly to the switchgear/transformer housing.

### **NOTE**

**Bolt the flange with a torque of 30 Nm. Enter the fixing torque in the installation protocol.**

## A. Straightening and Heating of the Cable

Before starting the cable preparation, train the cable end in the straight installation position and fix it.

The cable needs to be heated and straightened for the length of complete installation.

In case of graphite coating cover the cable with one layer of crepe paper.

Degrease and clean the oversheath.

Heat the cable by applying a heating device to the oversheath as shown in the TABLE BELOW.

Before stripping to the required dimensions, the cable needs to be cooled down to ambient temperature using slide rails.

Cable Cross Section	Heating Time/ Temperature
up to 400 mm <sup>2</sup>	4 h / 80 °C
up to 1200 mm <sup>2</sup>	5 h / 80 °C
up to 2500 mm <sup>2</sup>	6 h / 80 °C

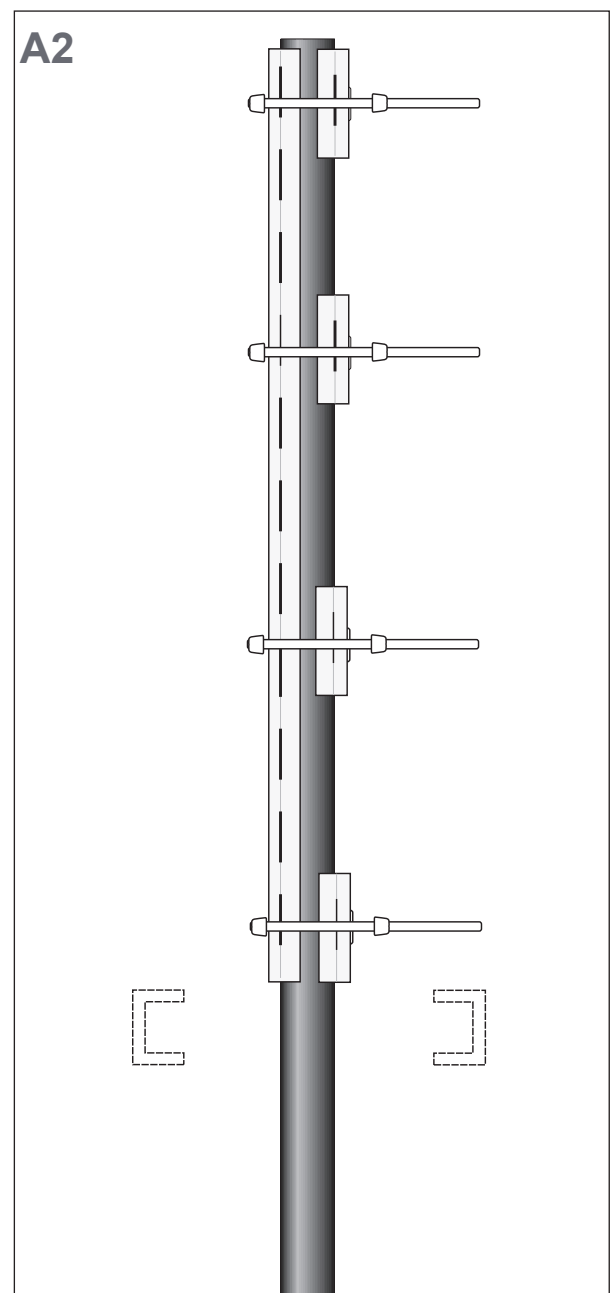
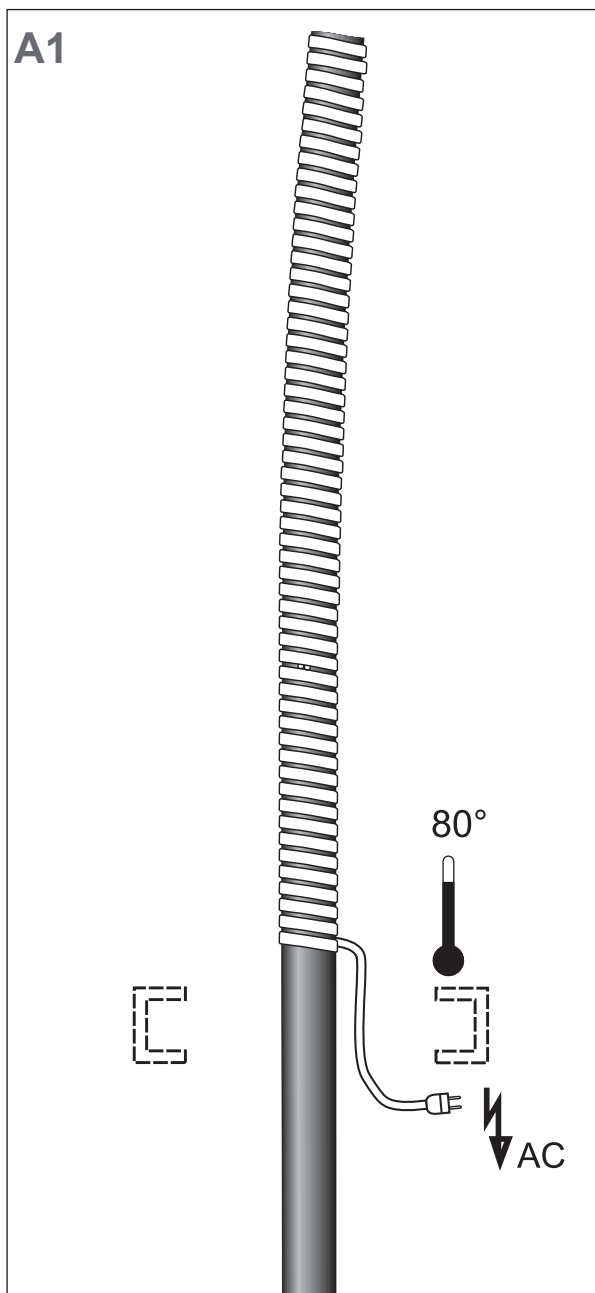

## B. Marking Reference Line

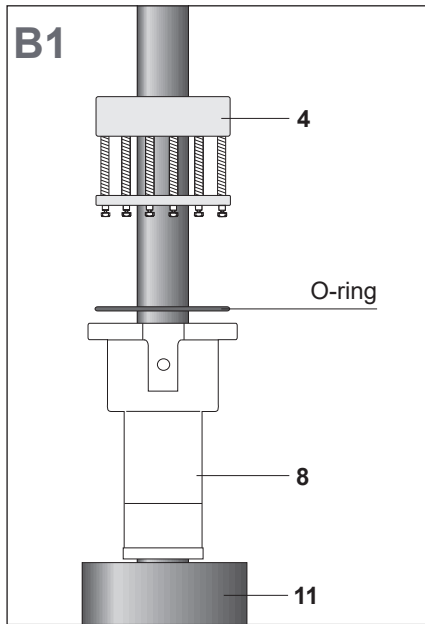

Move the heat shrinkable thick wall tubing (11), cable gland (8) and O-ring down the cable jacket as shown in the drawing.

Make sure enough room is left for the installation of the plug-in unit.

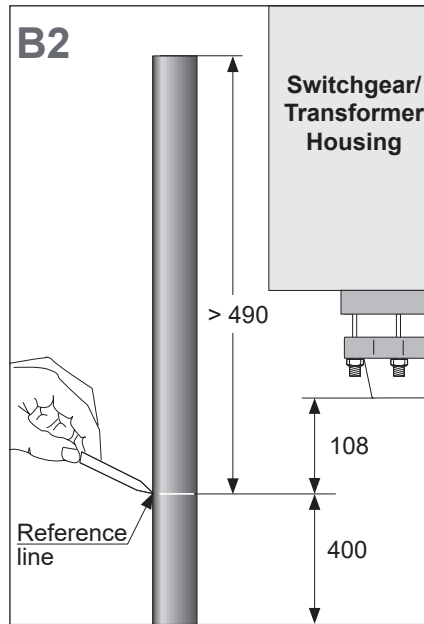

Mark the reference line on the cable 108 mm below the transformer switchgear housing as shown.

**This is the reference line for all further installation procedures. Make sure the remaining cable length above the reference line is at least 490 mm.**

**Remove the graphite coating or semiconductive layer, if any, up to 400 mm below the reference line.**

## C. Removing the Outer Jacket

### a. Cable without Metal Foil

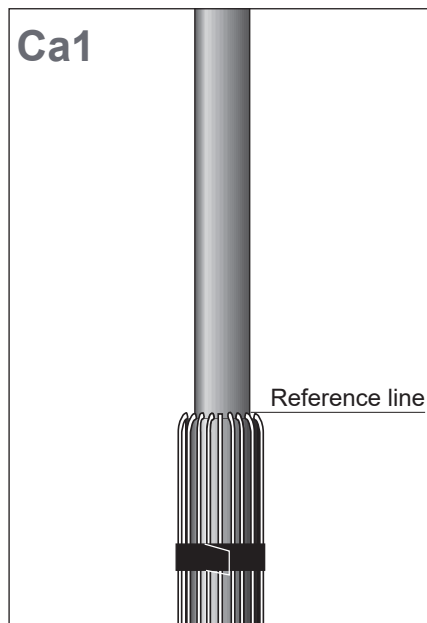

Starting out from the reference line, remove the outer jacket of the cable as shown.

Bend back the shield wires and fix them.

Continue with chapter D.

**b. Cable with Metal Foil**

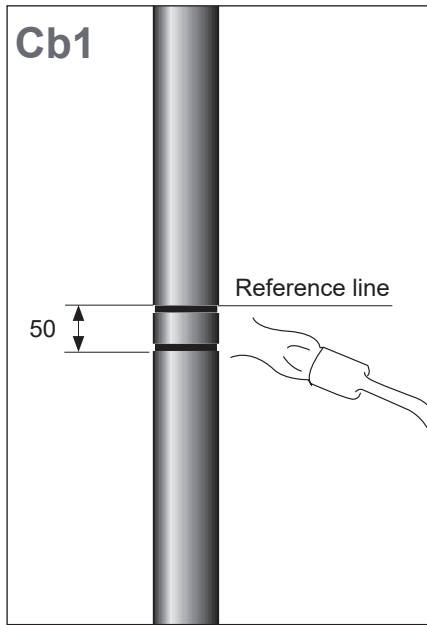

Heat the cable outer jacket (110) below the reference line. Soften approx. 50 mm of the surface.

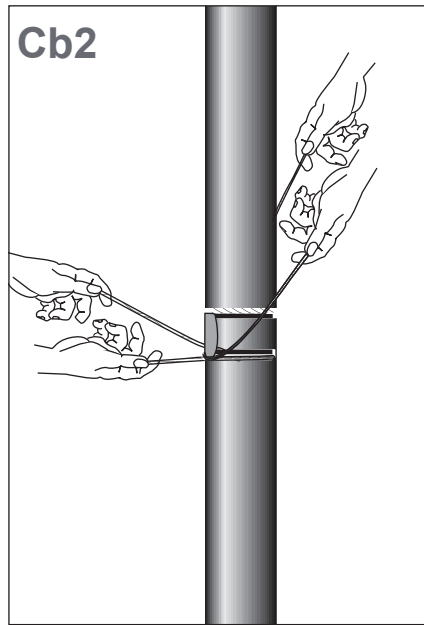

Cut through the outer jacket (110) with the supplied string. Remove the outer jacket from the metal foil (106) by slicing segments away with the string as shown in the picture.

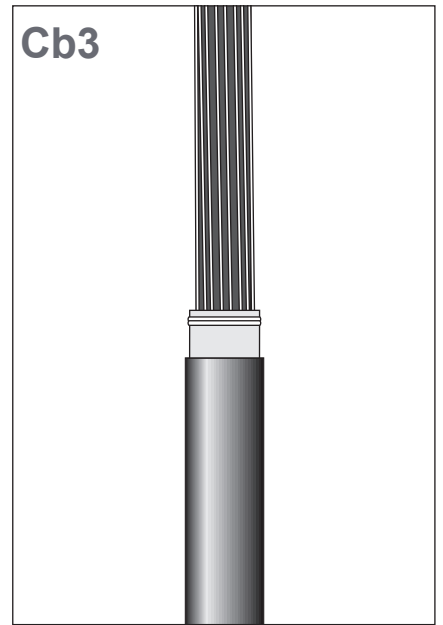

Fix the metal foil (106) with a wire binder. Clean the metal foil from traces of the outer jacket (if any). Remove the outer jacket, foil and bedding from the remaining cable end.

Wrap the copper mesh (15) onto the laminated metal foil (106).

Bend the shield wires (105) back onto the outer jacket and fix them temporarily in place with PVC tape. Fix the shield wires with a wire binder close to the outer jacket cut.

Install the roll spring (19) around the shield wires. Tighten the roll spring with a twisting action. Remove the wire binder which is near the cable oversheath.

Protect the roll spring with PVC tape (23).

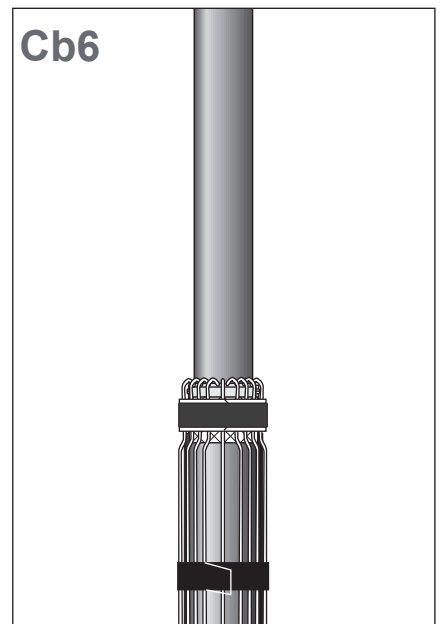
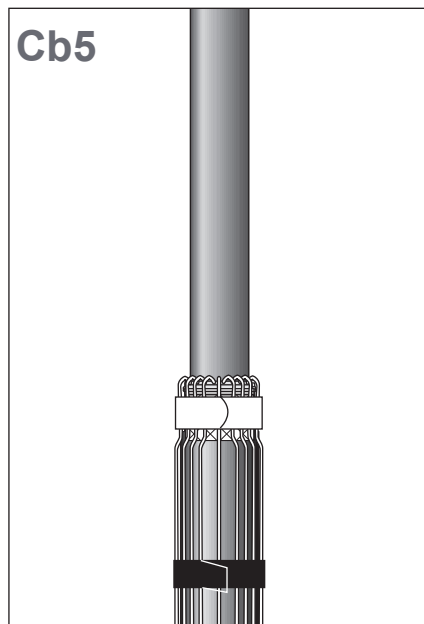
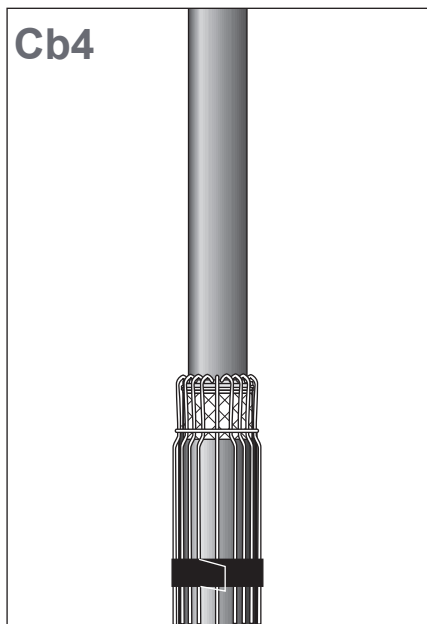

## D. Stripping the Outer Semicon Layer

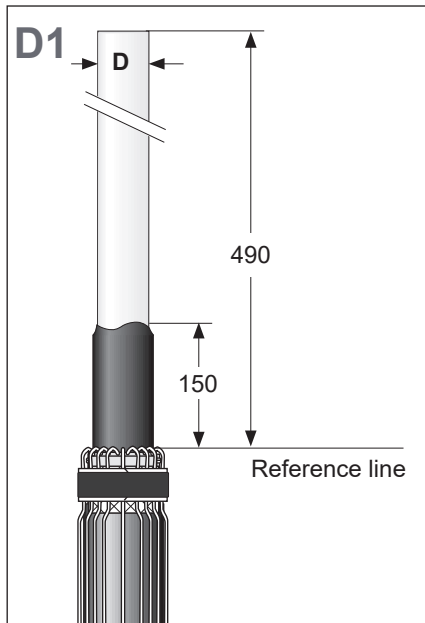

Thoroughly remove the outer semicon layer (104) to within 150 mm above the reference line until the diameter of the insulation (103) is  $D$  (see Table 1).

### NOTE

Smooth the insulation as requested on page 2 (General Instructions).

Cut the cable core exactly 490 mm above the reference line. The cut must be right-angled.

### NOTE

Do not damage the insulation.

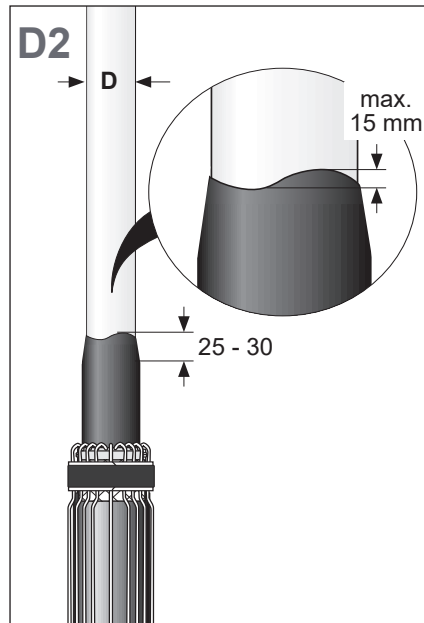

Chamfer the outer semicon layer in between 25 to 30 mm.

Polish the insulation (103) up to 250 mm from the outer semicon layer cut. Check the dimensions  $D$  as given in table 1.

$D$  must keep the values within the given tolerances.

Make sure the transition from the outer semicon layer to the insulation transition corresponds in terms of shape and max. height with the wave shown in the detail.

Table 1

Stress Cone ref. #	Application range $D$ (mm)
HVCA-PHVX145-SCONE-42/47	42 ... 47
HVCA-PHVX145-SCONE-46/51	46 ... 51
HVCA-PHVX145-SCONE-50/57	50 ... 57
HVCA-PHVX145-SCONE-56/61	56 ... 61
HVCA-PHVX145-SCONE-60/66	60 ... 66
HVCA-PHVX145-SCONE-65/71	65 ... 71
HVCA-PHVX145-SCONE-70/74	70 ... 74
HVCA-PHVX145-SCONE-73/78	73 ... 78



## E. Preparing the Conductor

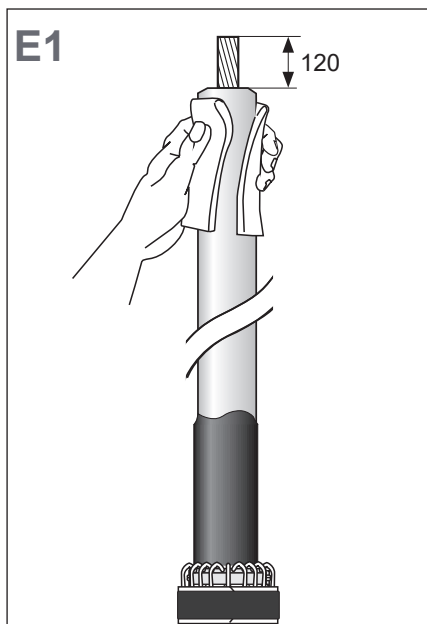

Remove 120 mm of the cable insulation (103) as shown.

Chamfer the insulation and deburr the edges with sandpaper.

Clean the cable insulation thoroughly using the supplied cable cleaner.

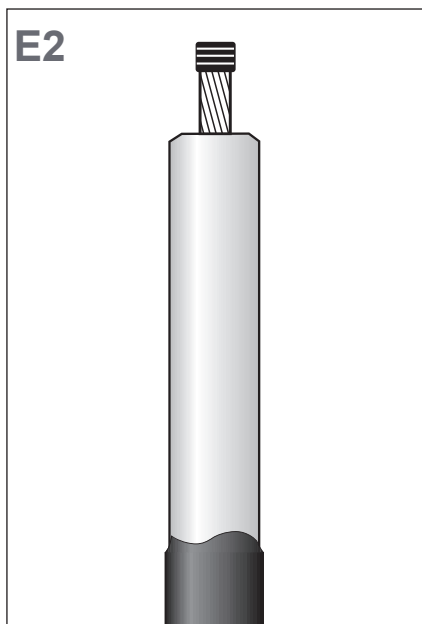

Protect the conductor (101) with PVC tape (23) as shown.

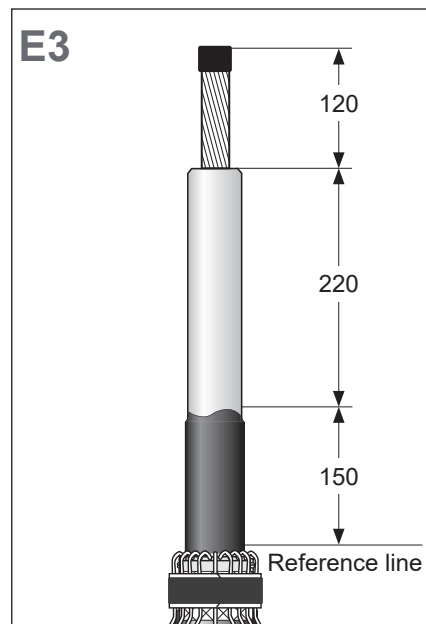

### **NOTE**

Adhere to the dimensions in the drawing.

Check the dimension of 220 mm.

### **NOTE**

Enter the dimensions of the prepared cable in the installation protocol.

## F. Preparation for the Cable Gland

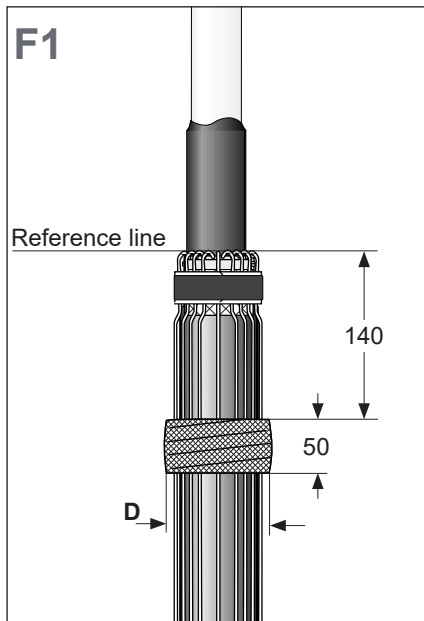

**140 mm below the reference line,**  
apply a 50 mm wide packing of cotton  
cloth tape.

**D** = Inner diameter of the gland.

## G. Installing of Stress Cone and Connector

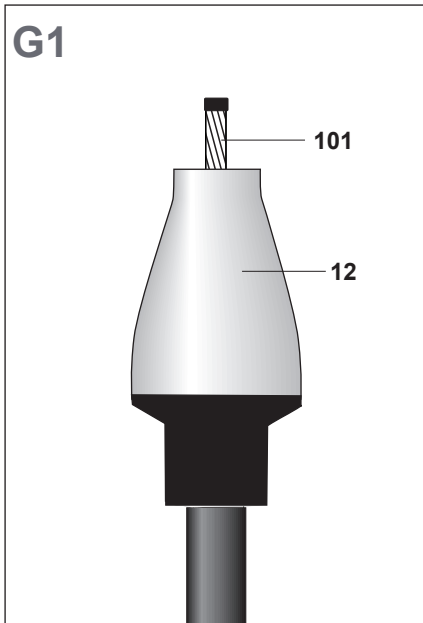

### Installing the silicone stress cone.

Before installing the silicone stress cone (12), check it for damages, failure or defects.

Clean the stress cone and protect it against any contaminations or damages.

If any, remove the PVC protection tape.

Clean the cable insulation (103) and the silicone stress cone bore with alcohol.

Thoroughly lubricate the cable insulation and the inner part of the silicone stress cone with silicon grease.

Push the silicone stress cone onto the cable core until the insulation levels with the stress cone top.

Clean all parts installed.

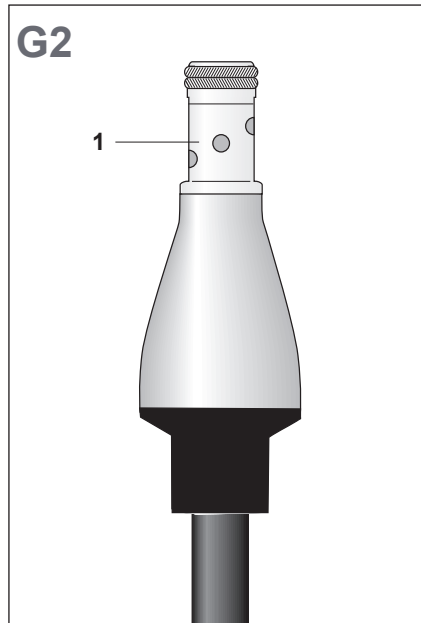

Remove the PVC tape from the conductor (101).

Place the connector barrel (1) onto the conductor and butt it to the insulation cut.

Fit the connector (1) on the conductor (101). Fix the connector by shearing off the bolts (10) using a box spanner or by any equivalent method.

## H. Installation of Plug-in Part

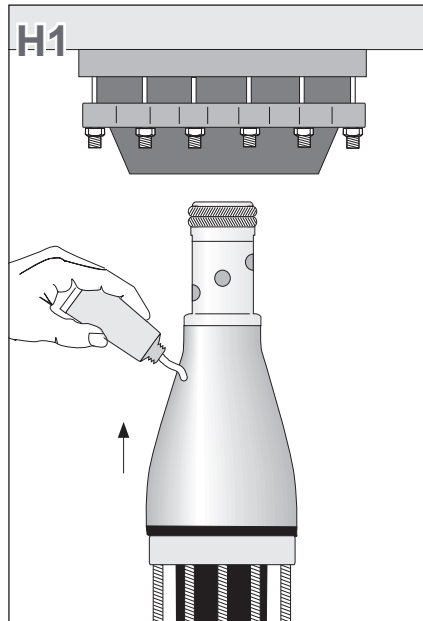

Remove the temporary protection from the connector stud. Clean and degrease the transparent cover part of the silicone stress cone (12) with alcohol.

### NOTE

**Do not touch the conductive part with any solvent.**

Clean the female part of the epoxy insulator (5) with Shell-Sol D60 or equivalent means. Remove Shell-Sol D60 remnants with alcohol. Grease the silicone stress cone with a special white lubricant.

Push it until the distance between the top of the cable gland (8) and the bottom of the epoxy insulator (5) is less than 30 mm.

**Make sure the cable gland and plug-in unit are moved vertically into position.**

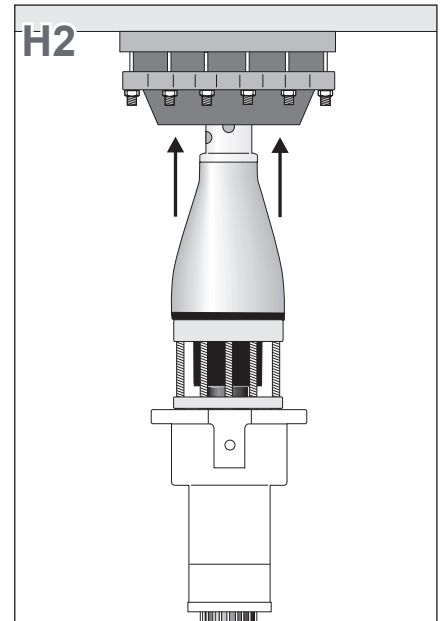
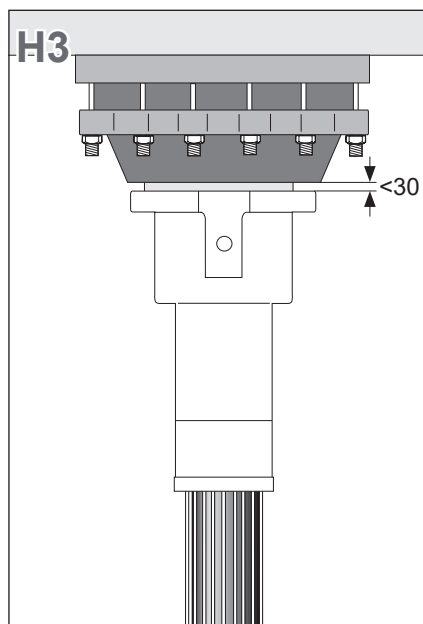

Push the cable with the male plug-in unit in a straight line into the epoxy insulator (5).

**Make sure the O-ring is in position.**

Bolt the cable gland (8) to the epoxy insulator (5) with the defined torque of maximally 34 Nm.

Fasten the bolts evenly around the diameter so that the male plug-in unit will not cant.

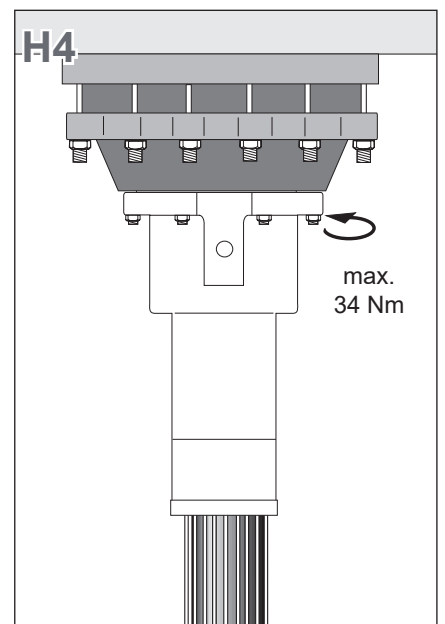

## I. Earthing the Cable Screen

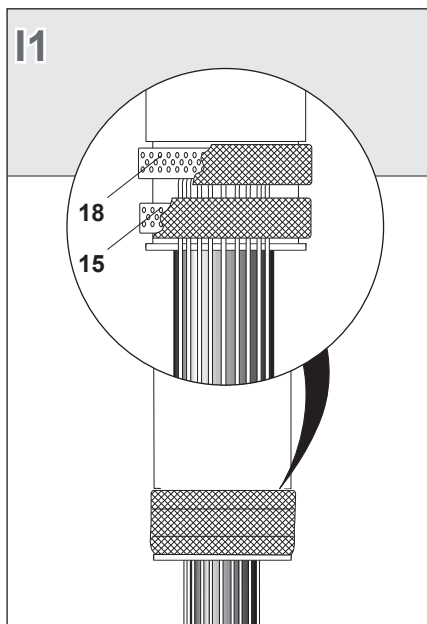

Abrade, degrease and clean the cable outer jacket and the cable gland.

Wrap two contact bands (18) around the cable gland and fix them with two or three layers of copper mesh tape (15).

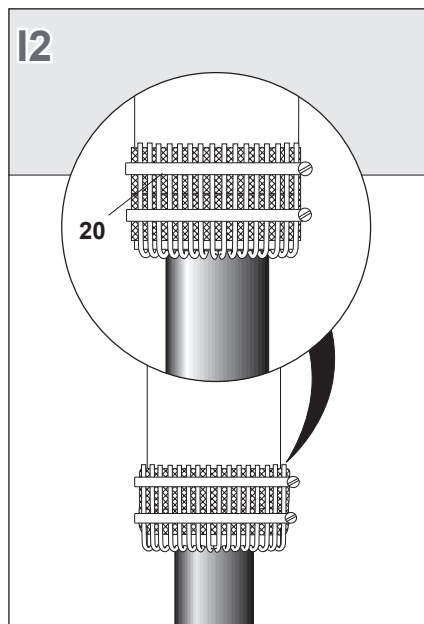

Cut the shield wires and bend them back onto the cable gland. Fix the shield wires as shown using two armoured clamps (20).

## J. Sealing the Cable Gland

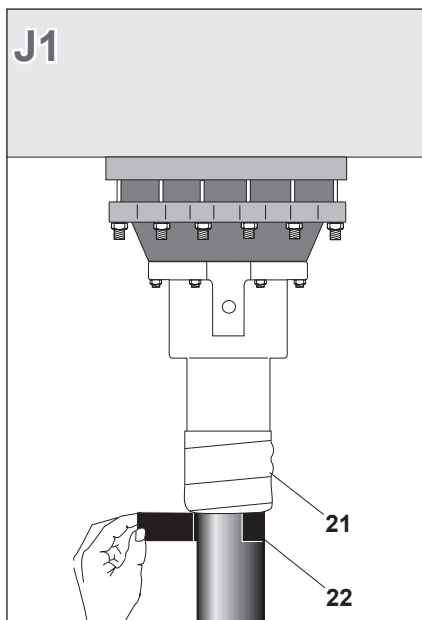

Cover the armour clamps with textile tape (21).

Wrap one layer of black mastic tape (22) around the outer jacket cut.

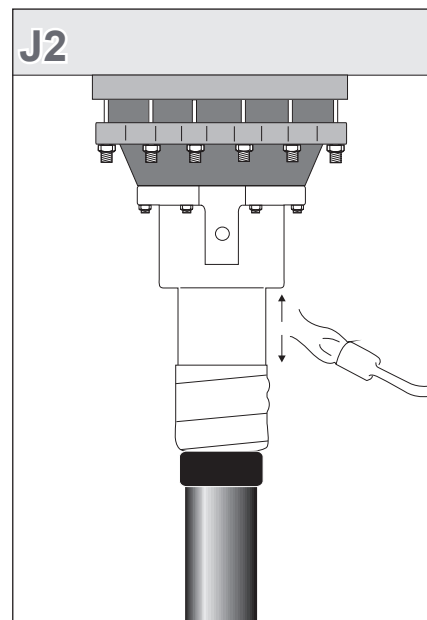

Preheat the cable gland stud.

Wrap 1 layer of black mastic (22) around the gland above the textile tape.

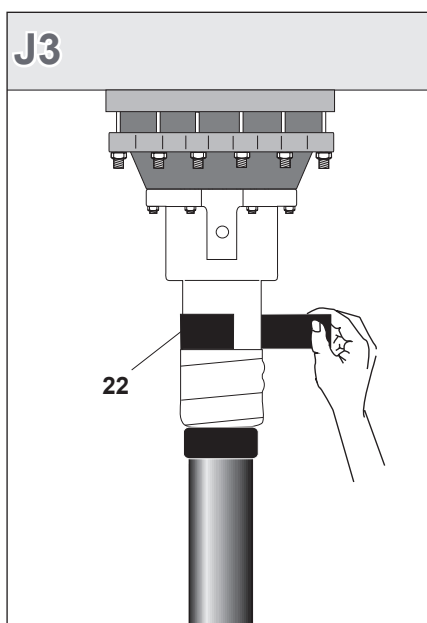

Position the heat shrinkable thick wall tubing (11) approx. 100 mm on the gland stud and shrink it into place. Start shrinking at the top then move downwards.

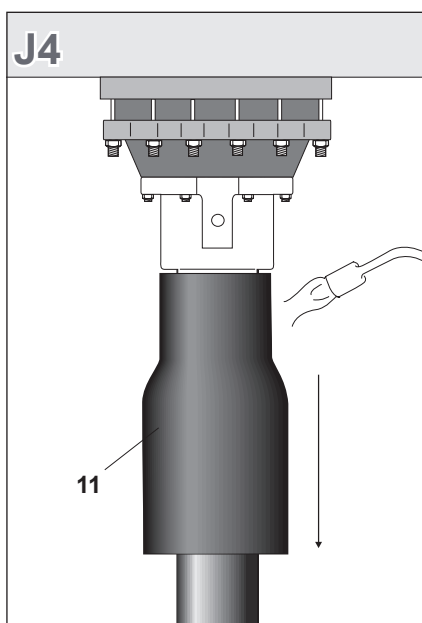

The tubing is fully shrunk when the outer surface is smooth, has a glossy appearance and a flow of sealant is visible at each open end. Intimate surface contact should be made along the whole tubing length, conforming to the profile of the components underneath. The tubing should be smooth and wrinkle free with inner components clearly defined.

Connect the ground lead to the substation ground according to local requirements (6 x M10).

