

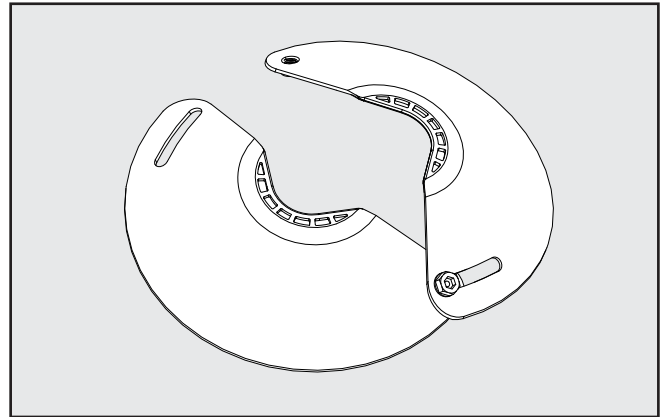

INSTALLATION INSTRUCTIONS

EPP-3148-7/23
PII-70271

BISG-100/400; BISG-100/600



TE Insulation & Protection

Safety Instructions

⚠ DANGER

When installing electrical power system accessories, failure to follow applicable personal safety requirements and written installation instructions could result in fire or explosion and serious or fatal injuries.

⚠ DANGER

As TE Connectivity (TE) has no control over field conditions which influence product installation, it is understood that the user must take this into account and apply his own experience and expertise when installing product.

⚠ DANGER

Working around energized high-voltage systems may cause serious injury or death. Installation should be performed by personnel familiar with good safety practice in handling high-voltage electrical equipment. De-energize and ground all electrical systems before installing product.

⚠ DANGER

Power distribution and transmission products must be properly selected for the intended application. It must be installed and serviced by competent personnel who have been trained and understand proper safety procedures. These instructions are written for such personnel and are not a substitute for adequate training and experience in safety procedures.

⚠ CAUTION

Read and understand the contents of these instructions before installation and follow all locally approved procedures and safety practices before installing or operating this equipment.

⚠ CAUTION

These instructions cannot cover all details or variations in the equipment, procedures, or processes described, nor provide directions for meeting every possible contingency during installation, operation, or maintenance. When additional information is desired to satisfy a problem not covered sufficiently for the user's purpose, please contact your TE sales representative. These instructions are not intended to supersede or replace existing safety and operating procedures.

NOTICE

Upon receipt of a product, inspect it thoroughly for damage and loss of parts incurred during shipment. If damage or loss is discovered, file a claim with the carrier immediately or contact your TE representative.

Please dispose of all waste according to environmental regulations.



For more information: te.com/energy

Tyco Electronics Raychem GmbH
a TE Connectivity Ltd. Company
Finsinger Feld 1
85521 Ottobrunn/Munich, Germany
Tel: +49-89-6089-0
Fax: +49-89-6096-345

Customer Service

For 24 hour customer service, call 800-327-6996.

TE Connectivity

8000 Purfoy Road
Fuquay-Varina NC 27526
Tel: (919) 552-3811
Fax: (919) 557-8404

The Information contained in these installation instructions is for use only by installers trained to make electrical power installations and is intended to describe the correct method of installation for this product. However, TE Connectivity (TE) has no control over the field conditions which influence product installation. It is the user's responsibility to determine the suitability of the installation method in the user's field conditions. TE's only obligations are those in TE's standard Conditions of Sale for this product and in no case will TE be liable for any other incidental, indirect or consequential damages arising from the use or misuse of the products.

Raychem, TE, TE Connectivity and TE connectivity (logo) are trademarks.
© 2023 TE Connectivity. All Rights Reserved.

Installation Instructions

Components for installation

Part Description	Qty.
BISG-100/400 or BISG-100/600 halves	2pcs
Bolts	2pcs

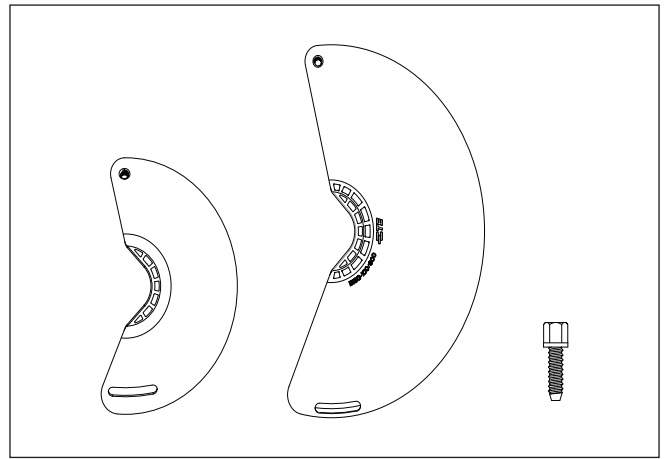

1. Attach BISG

Attach 2 BISG halves together using one bolt. The bolt should be finger tight.

NOTICE

The threaded boss should be below the part.

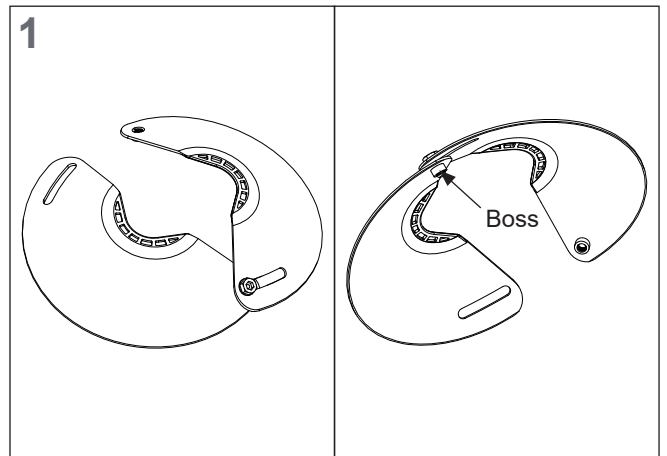

2. Accommodate insulator diameters

The BISG-100/400 can accommodate insulator diameters ranging from 38 mm (1.5") to 102 mm (4") depending on where the pivot bolt is installed in the slot.

The BISG-100/600 can accommodate insulator diameters ranging from 38 mm (1.5") to 114 mm (4.5") depending on where the pivot bolt is installed in the slot.

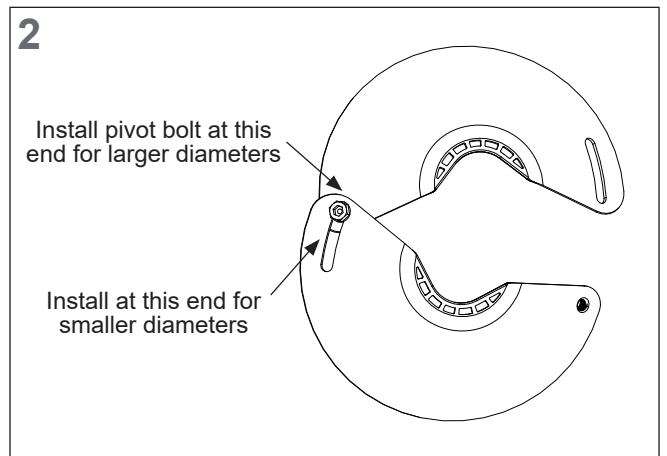

3. If insulator diameter is larger than 102 mm (4") for BISG-100/400 or 114 mm (4.5") for BISG-100/600

If the installation is on an insulator with a diameter larger than 102 mm (4"), the grid area on top of the BISG may be trimmed away with a cutting tool.

The BISG-100/400 can be trimmed to fit up to a diameter insulator 120 mm (4.75").

The BISG-100/600 can be trimmed to fit up to a diameter insulator 159 mm (6.25").

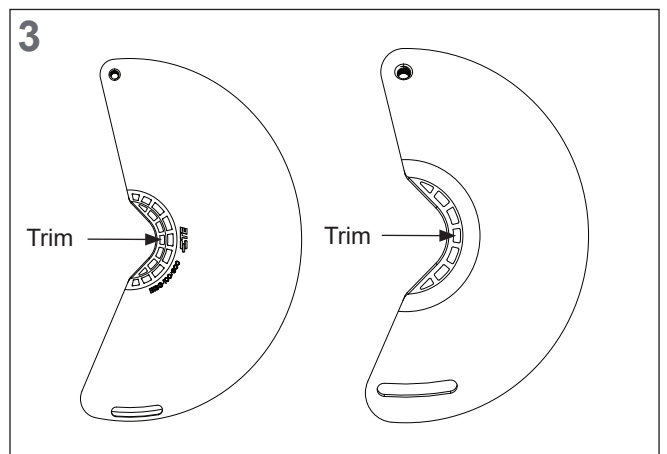

4. Position BISG

Position the product between the insulator skirts.

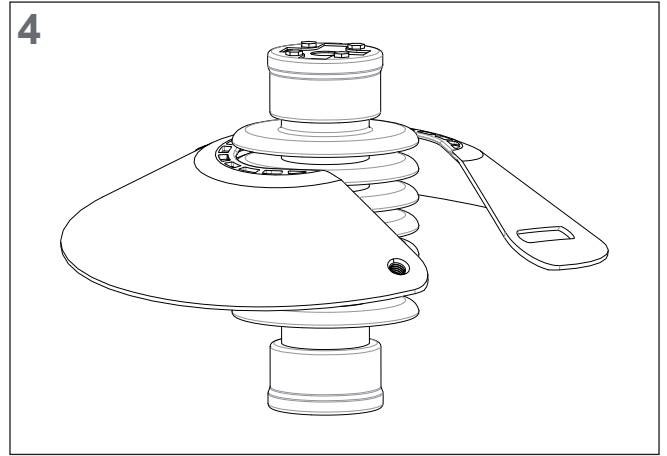

5. Tighten BISG

Step 3: Tighten the BISG by sliding the slotted half over the threaded hole until the guard is securely around the insulator core. Install the second bolt through the threaded hole and turn with a wrench until tight and then apply a full additional turn 2.7 - 4 Nm (approximately 2 – 3 ft-lbs). Repeat the wrench tightening process with the first bolt.

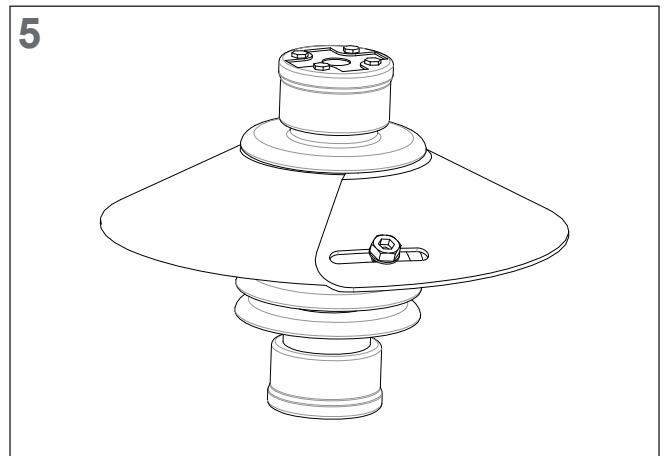

6. Typically Installed on vertical insulators

Typically, the BISG is installed between the upper most two skirts on vertical insulators.

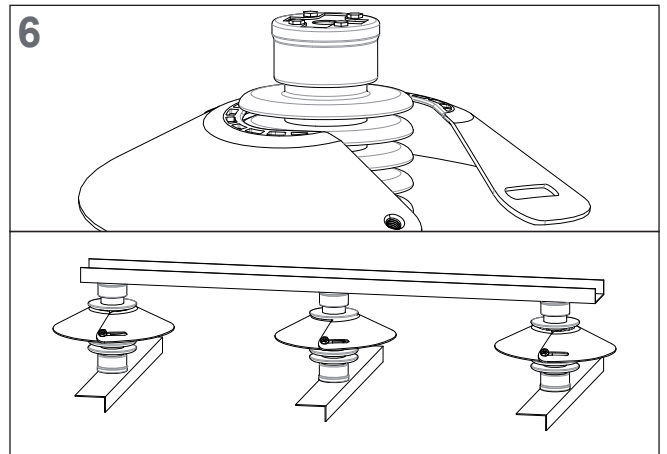

7. Install on closely spaced vertical insulators

When installing the product on closely spaced vertical insulators, like those found on hook switch disconnects, one guard should be installed between the skirts closest to the switch. The second guard should be placed between the next skirts as shown to ensure the guards do not touch. Field trim if necessary.

