

SPECIFICATIONS:
All values are typical at +25°C (+77°F), 80Hz, unless otherwise stated.

Parameters	Value	Unit	Notes
Dynamic Range	±25	g	
Calibration Tolerance	±3	%	Reading
Frequency Response ±3dB	2-10000	Hz	
Resonance Frequency	35	KHz	Analog Signal Test, Typical
Transverse Sensitivity	<8	%	
Temperature Response	See typical temperature response curve		
Non-Linearity	±1(±2)	%	FSO (Reading)
Residual Noise (passband)	<9	mg RMS	72dB Dynamic Range
Shock Limit	2000	g	
Temperature Sensor Tolerance	±2	°C	-40~+60
Power Supply	+3.6	Vdc	Replaceable Battery Saft LS17330
Power Consumption (Average)	Idle Mode	5	uA
	Tx Mode (max)	25	mA
	Rx Mode	390	uA
			Typical
Operating Temperature	-40 to +60	°C	With Battery
Storage Temperature	-40 to +80	°C	Without Battery
Humidity Limits	<95	%	Non-Condensing
Environmental Rating	IP66 & IP67		
Wireless Protocol	LoRa WAN™ Class-A, BLE5		BLE connection is available for configuration mode
BLE5 Work Frequency	2.4	GHz	
LoRa Work Region	Eu 868.3M or USA 915M	Hz	Other regions available upon request
Maximum Transmit Power	+8	dBm	
Receive Sensitivity	-137	dBm	SF12BW125
Resolution	12	bits	
Activation	OTAA		ABP available upon request
Activation Keys	Factory Defined		Customization available upon request
Battery Life	Refer to datasheet		
Material	Stainless Steel 316L (case) and Plastic PET (housing)		
Weight	155	g	Without Battery
Mounting Torque	17	lb-In	

REVISIONS				
REV	DESCRIPTION	DRAWN/DATE	CHECKED/DATE	APPR./DATE
A	INITIAL RELEASE.	JZ/4-17-23	PP/4-17-23	PL/4-17-23
B	Tx POWER, RECEIVE SENSITIVITY SEPC UPDATED.	JZ/5-11-23	PP/5-11-23	PL/5-11-23

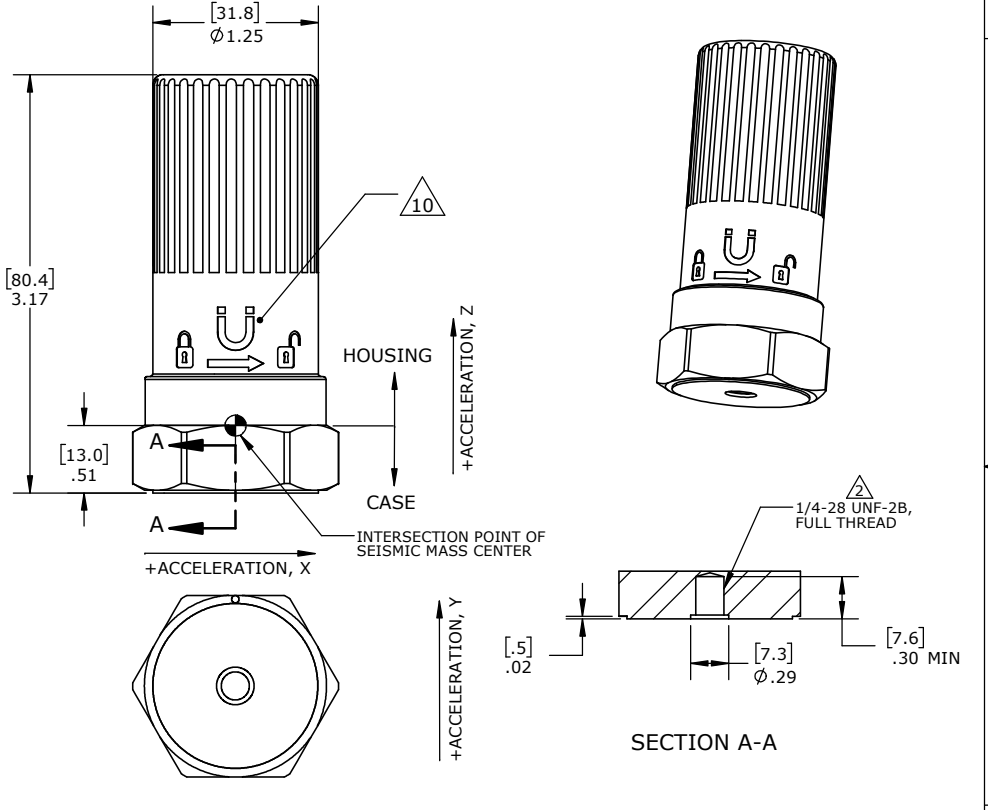

ACCELEROMETER

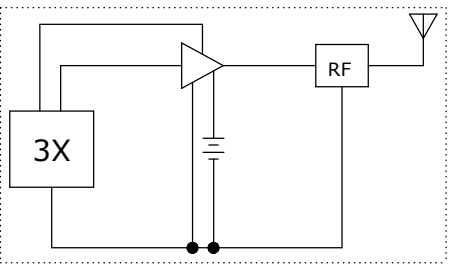

TYPICAL TEMPERATURE RESPONSE

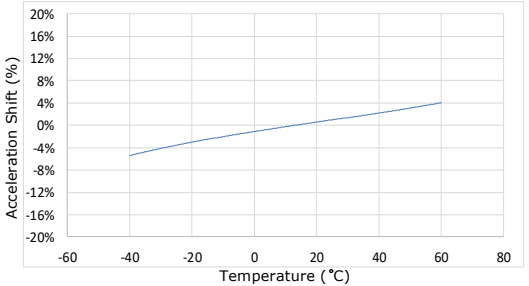

Manufacturer: Measurement Specialties (China) LTD
No.26 LangShan Road,
518057 Shenzhen-Nanshan District China.

UNLESS OTHERWISE SPECIFIED:		NAME	DATE
DIMENSIONS ARE IN INCHES [MM]	DRAWN	J. Zhao	4-26-22
TOLERANCES:	CHECKED	P. Li	4-26-22
ANGULAR ±5°	ENG APPR.	A. Rao	4-26-22
TWO PLACE DECIMAL ±.03 [.8]			
THREE PLACE DECIMAL ±.010 [.25]			
MATERIAL			
FINISH			
PROPRIETARY AND CONFIDENTIAL	COMMENTS:		
THE INFORMATION CONTAINED IN THIS DRAWING IS THE SOLE PROPERTY OF MEASUREMENT SPECIALTIES, INC. ANY REPRODUCTION IN PART OR AS A WHOLE WITHOUT THE WRITTEN PERMISSION OF MEASUREMENT SPECIALTIES, INC. IS PROHIBITED.	DO NOT SCALE DRAWING INTERPRET GEOMETRIC TOLERANCING PER ANSI Y14.5M-1994		



TITLE: MODEL 8931N-NX, ACCELEROMETER		
SIZE DWG. NO. B OD-8931N-NX	REV B	
SCALE:	WEIGHT:	SHEET 1 OF 2

NOTES:

- 1 MODEL NUMBER: 8931N-NX-E (FOR 868.3MHz); 8931N-NX-A (FOR 915MHz).
- 2 FOR USE WITH TE Connectivity. MOUNTING STUD:
 MODEL AC-D03636, 1/4-28 TO 1/4-28 (SUPPLIED BY TE CONNECTIVITY AS STANDARD)
 MODEL AC-D03664, 1/4-28 TO M5
 MODEL AC-D03665, 1/4-28 TO M6
- 3 TEMPERATURE SENSOR: Ni1000 (CLASS B).
- 4 REFER TO THE DATASHEET FOR BATTERY LIFE, WHICH IS SUBJECT TO AMBIENT TEMPERATURE AND THE USER'S SELECTION OF TRANSMISSION INTERVALS, SAMPLING RATE,...
- 5 COMPLY WITH FCC, IC, RED.
- 6 COMPLY WITH RoHS EU DIRECTIVE 2002/95/EC.
- 7 IF THE DEVICE IS USED IN A MANNER NOT SPECIFIED BY THE MANUFACTURER, THE PROTECTION PROVIDED BY THE DEVICE MAY BE COMPROMISED.
- 8 CAUTION THERE IS A RISK OF EXPLOSION IF THE BATTERY IS REPLACED BY AN INCORRECT BATTERY.
- 9 BATTERY SHOULD ONLY BE REPLACED BY QUALIFIED PERSON.
- 10 REED SWITCH FUNCTION TO BE DEFINED BY TE.
- 11 MEASUREMENTS AT PCB LEVEL THROUGH CABLE, NON-SIGNALING MODE.
- 12 MANUFACTURER'S DETAILED INFORMATION FOUND IN USER MANUAL AS ALLOWED DUE TO PRODUCT SIZE CONSTRAINS.
- 13 LABEL MATERIAL: BRADY B-473 THERMAL TRANSFER PRINTABLE GLOSSY WHITE STATIC DISSIPATIVE POLYESTER.

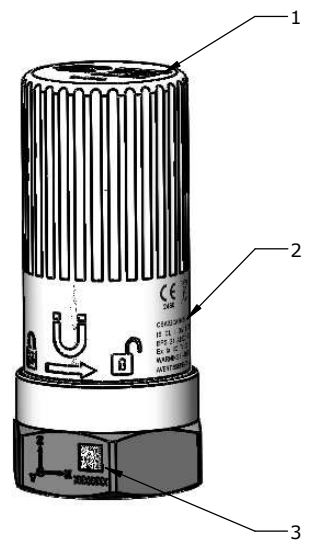

Marking 1 (Labeling)

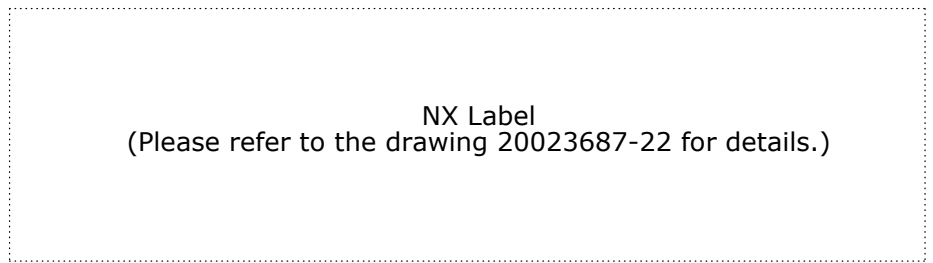

Marking 2 (Labeling sample)

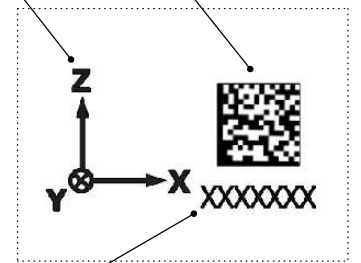

Serial Number (XXXXXXXX) Marking 3 (Lasering sample)

SIZE	DWG. NO.	REV
B	OD-8931N-NX	B
		SHEET 2 OF 2