

PT9420 installation instructions

WARNING!! • Remove spool locking screw prior to installation!

WARNING!! • Do not free release measuring cable!

WARNING!! • Do not over extend measuring cable!

WARNING!! • Limit misalignment to 5° maximum!

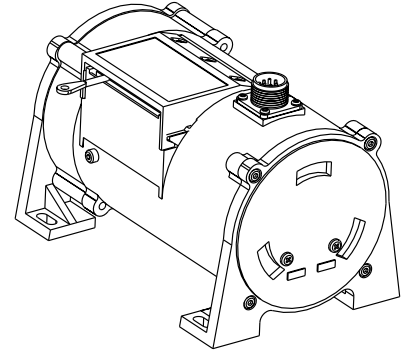

MECHANICAL

1. Remove spool locking screw.
2. Mount transducer via the 4 mounting feet to a flat solid surface.
3. Connect measuring cable to moving object.

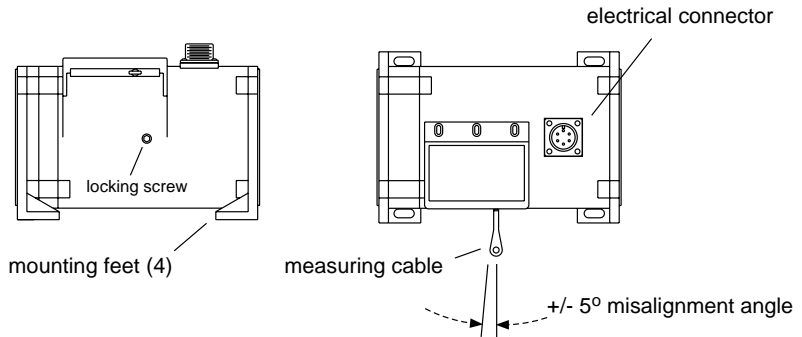

ELECTRICAL

4. Connect system wiring.
5. Using zero and span controls, calibrate to exact measurement range.

RECOMMENDED INSTALLATION

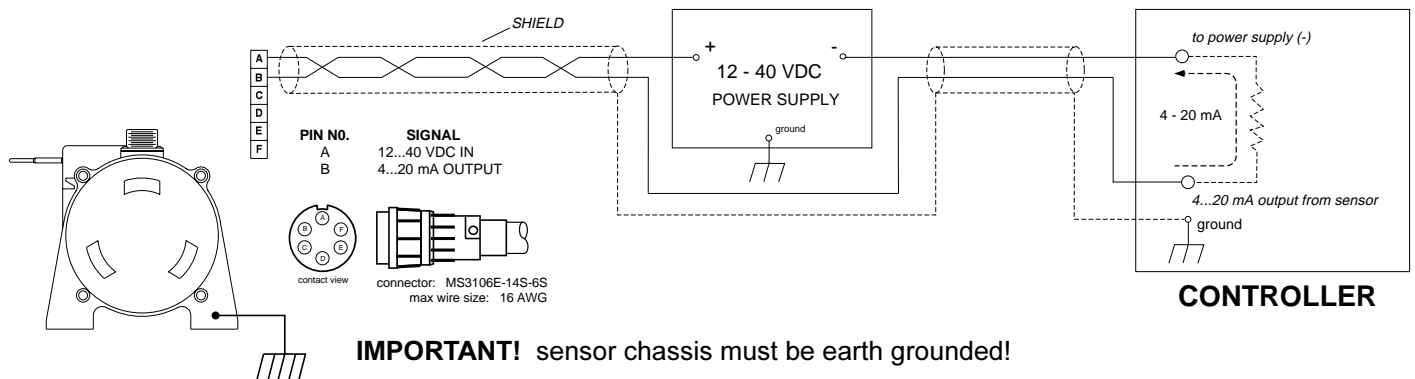

CHANGING CALIBRATED RANGE

1. Remove Phillips-head plugs to expose flat head zero and span trimming potentiometers.
2. Extend measurement cable to 4mA position and adjust "zero" pot.
3. Extend cable to 20 mA position and adjust "span" pot.
4. Repeat steps 2 and 3.
5. Replace plugs.

