

Assembly instructions for SRC

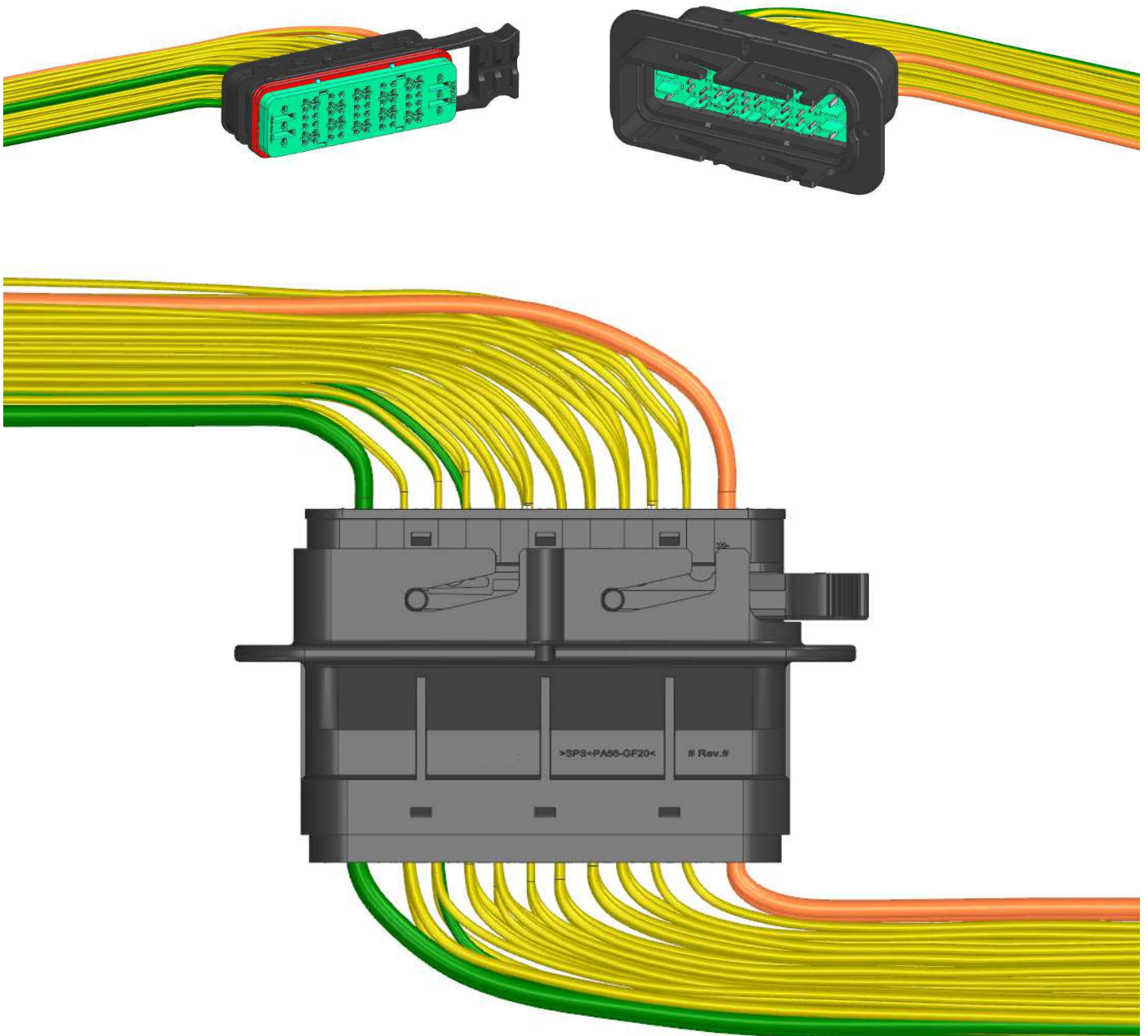

TABLE OF CONTENTS



Tools required
- Page 4

**PLEASE READ DISCLAIMER AND RECOMMENDATION NOTES
ON PAGE 51 BEFORE USING THIS DOCUMENT**







| | | | |
|---|---|--|---|
|  | <p>Female assembly overview - Page 5</p> |  | <p>Male assembly overview - Page 21</p> |
|  | <p>Open TPA - Page 6</p> |  | <p>Open TPA - Page 22</p> |
|  | <p>Signal blind cavity plug - Page 7</p> |  | <p>Signal blind cavity plug - Page 23</p> |
|  | <p>Power blind cavity plug - Page 11</p> |  | <p>Power blind cavity plug - Page 25</p> |
|  | <p>Signal terminals - Page 12</p> |  | <p>Signal terminals - Page 26</p> |
|  | <p>2.5mm² terminals - Page 13</p> |  | <p>2.5mm² terminals - Page 27</p> |
|  | <p>Power terminals - Page 14</p> |  | <p>Power terminals - Page 28</p> |
|  | <p>Close TPA - Page 15</p> |  | <p>Close TPA - Page 29</p> |
|  | <p>Attach conduit interface - Page 16</p> |  | <p>Attach conduit interface - Page 31</p> |

Table of contents continued on next page

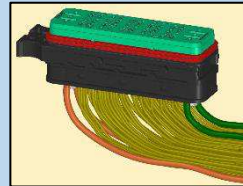

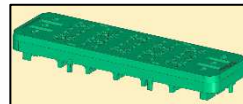
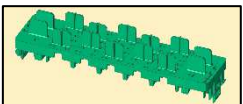
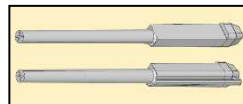
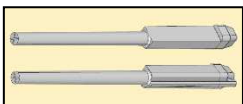
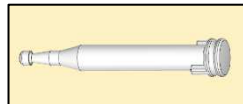
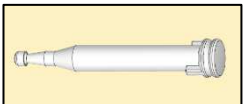
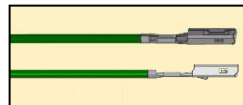
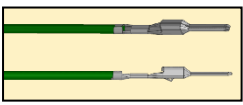
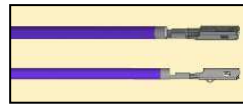
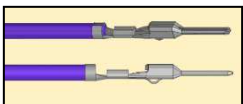
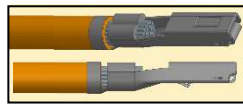
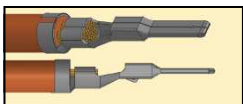
TABLE OF CONTENTS

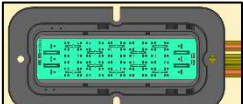

Visual inspection
- Page 36

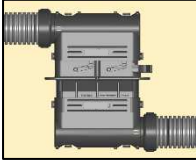

Final connector mating
- Page 37

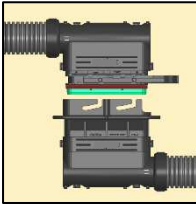

Connector un-mating
- Page 40

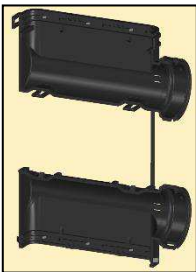

Conduit interface removal
- Page 41

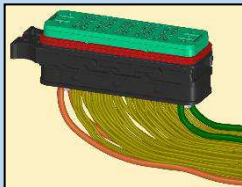

Female connector maintenance

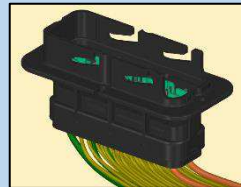

Male connector maintenance

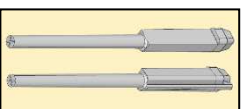

Signal blind cavity plug removal
- Page 43

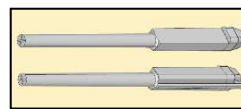

Signal blind cavity plug removal
- Page 47

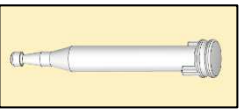

Power blind cavity plug removal
- Page 44

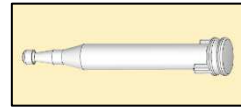

Power blind cavity plug removal
- Page 48

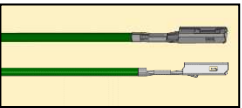

Signal and 2.5mm² terminals removal
- Page 45

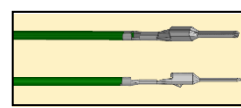

Signal and 2.5mm² terminals removal
- Page 49

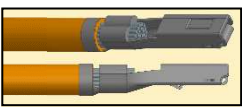

Power terminals removal
- Page 46

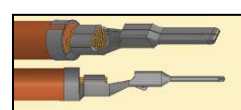

Power terminals removal
- Page 50

Disclaimer and reference documents - Page 51

TOOLS REQUIRED

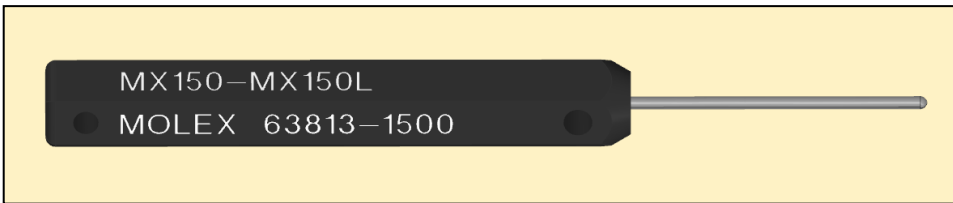
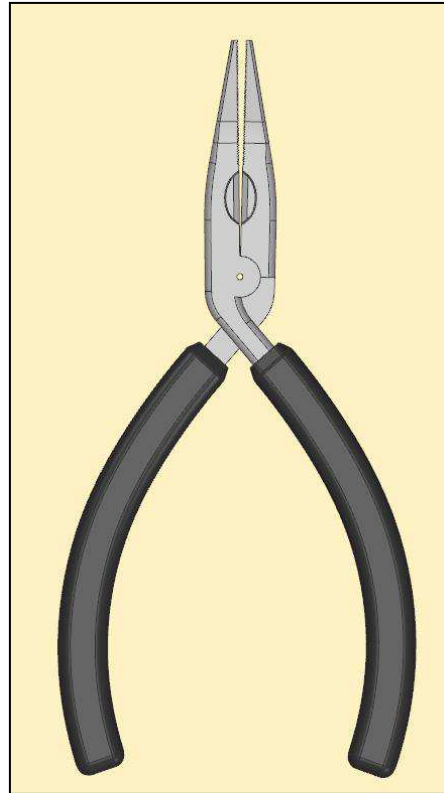
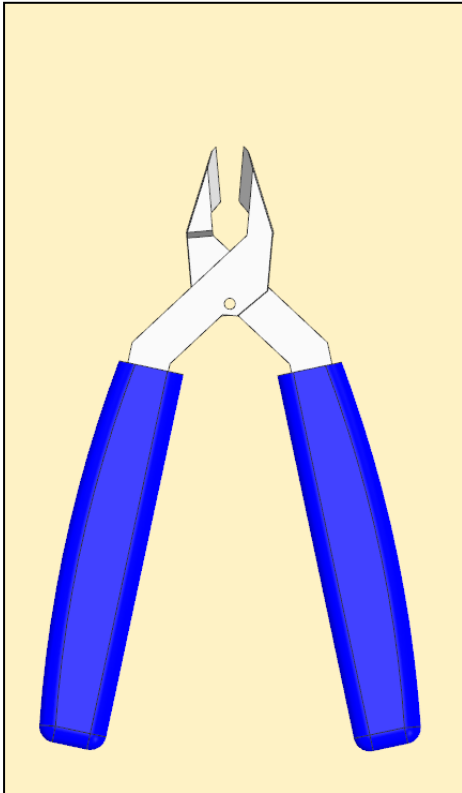

FEMALE ASSEMBLY OVERVIEW

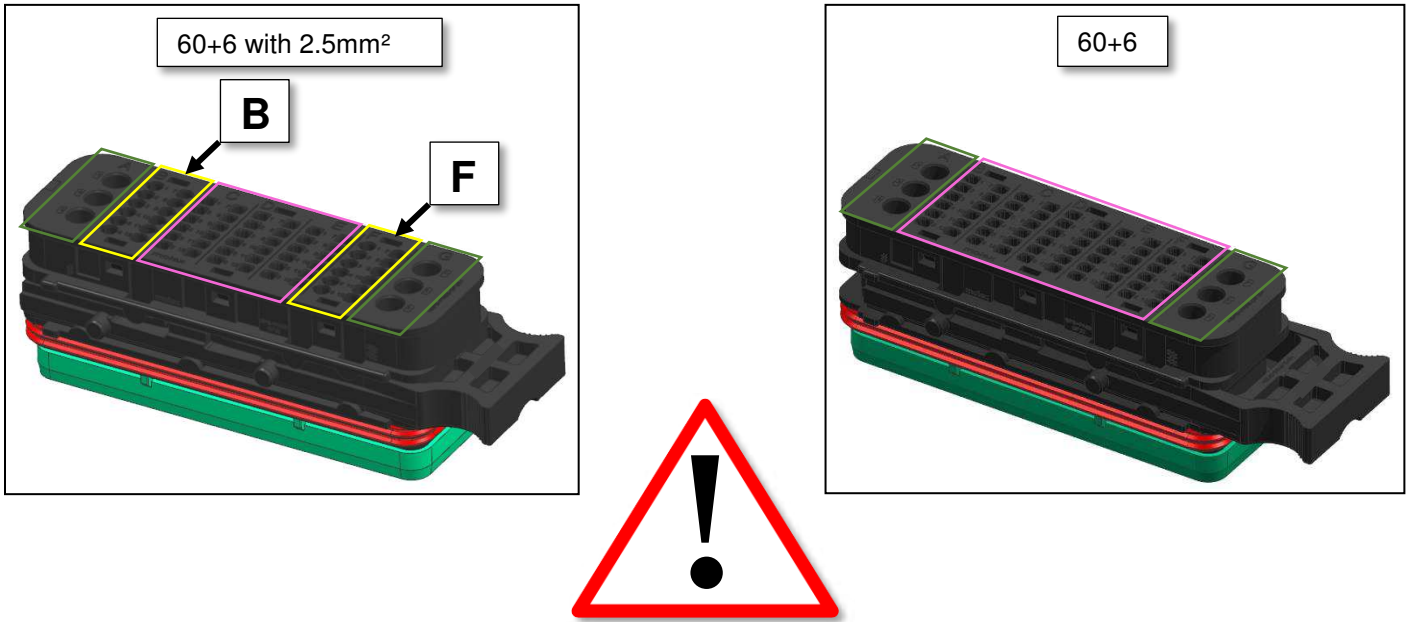

- 2.5mm² only available on some configurations and only in **B and F** locations as highlighted in yellow above
- For all configurations please see 2500000 thru 2500015

| Power | 2.5mm ² | Signal |
|---|---|--|
| | | |
| <p>Power Cable Insulation Diameter Range 3.0 – 5.0mm</p> | <p>2.5mm² Cable Insulation Diameter Range 1.5 – 3.0mm</p> | <p>Signal Cable Insulation Diameter Range 1.5 - 2.7mm</p> |

STEP 1 – OPEN TPA

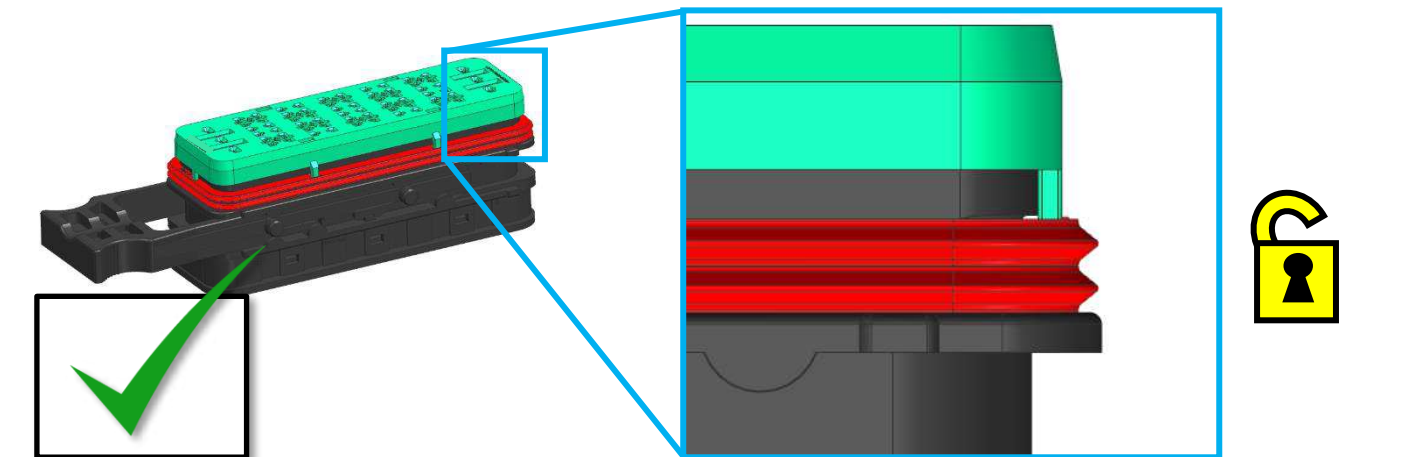
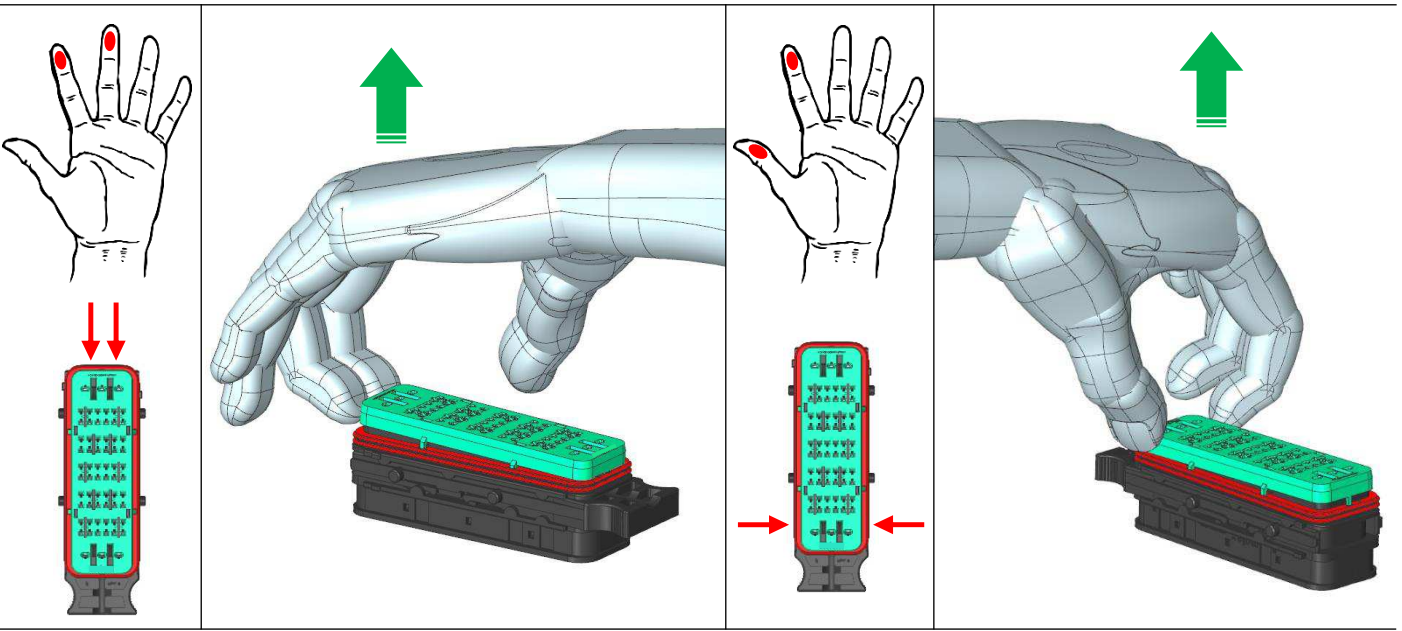
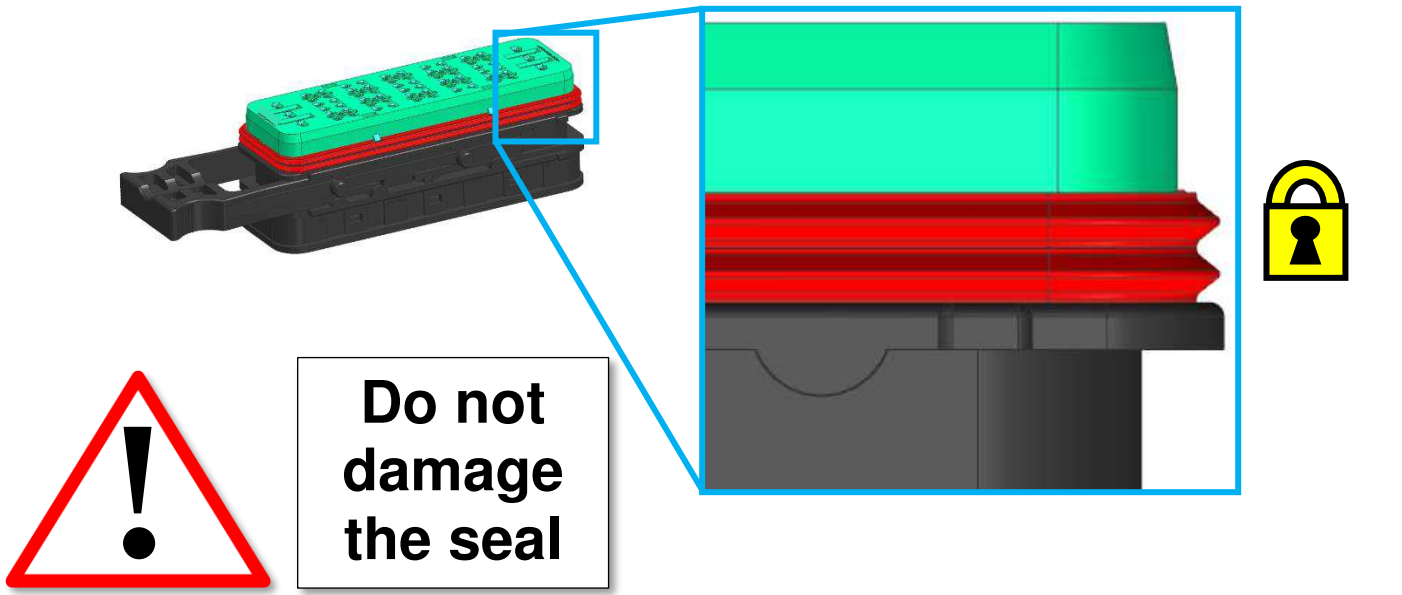

STEP 2 – INSERT SIGNAL BLIND CAVITY PLUGS

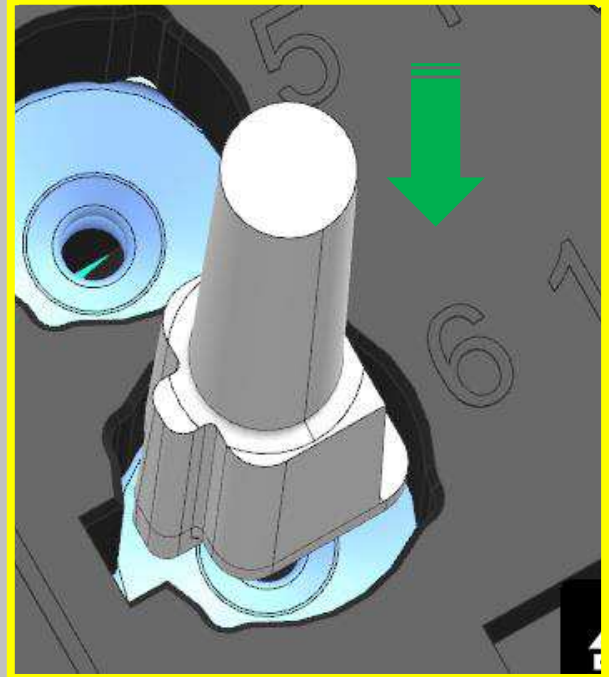
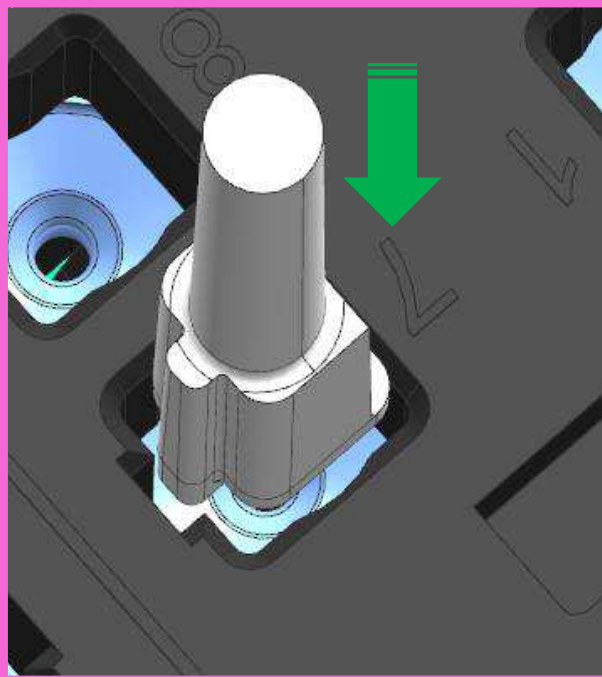
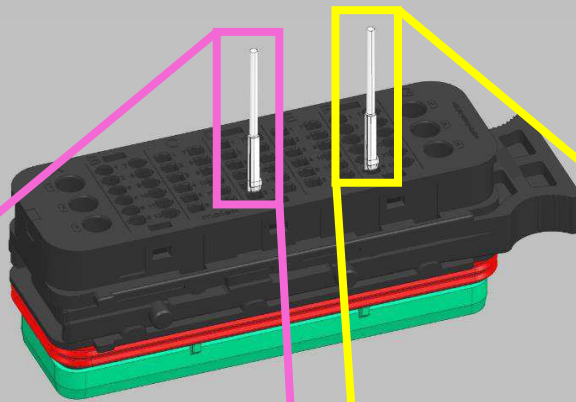
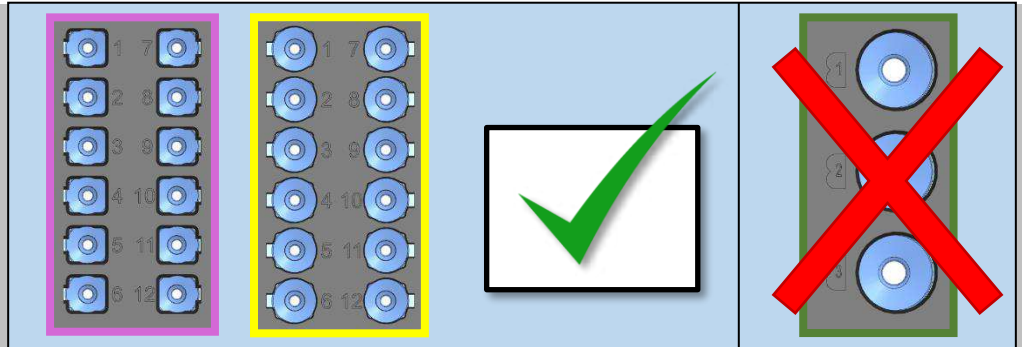
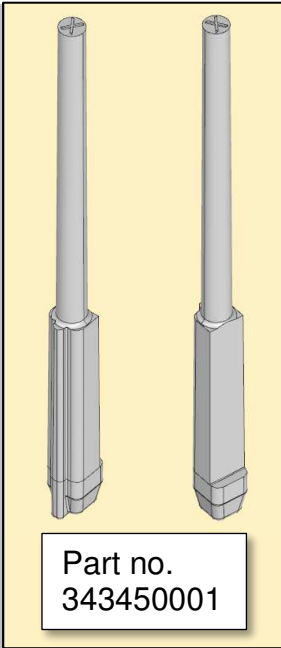

Demonstration example



See next page

STEP 2 – INSERT SIGNAL BLIND CAVITY PLUGS

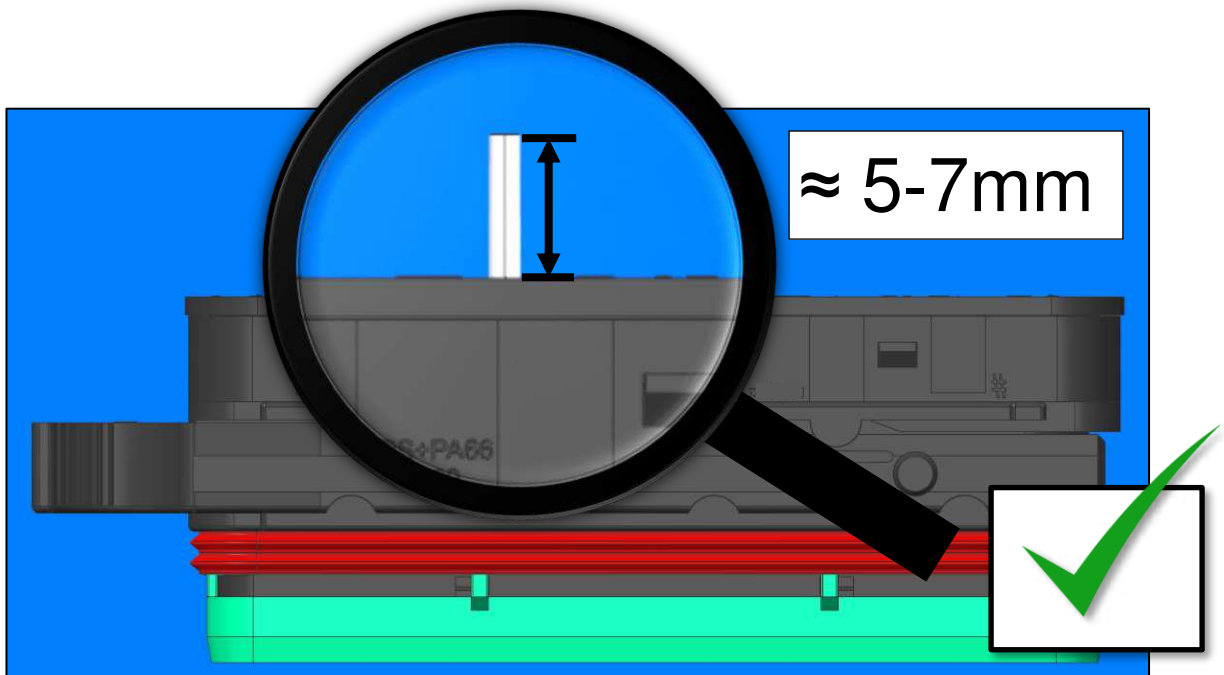
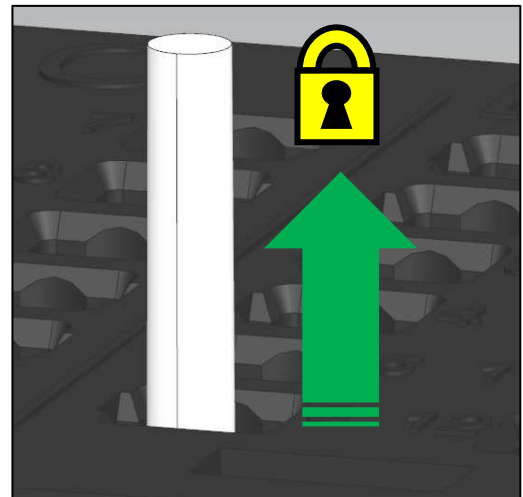
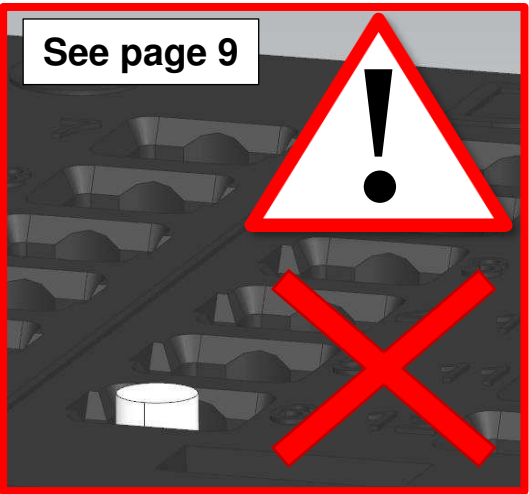
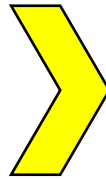
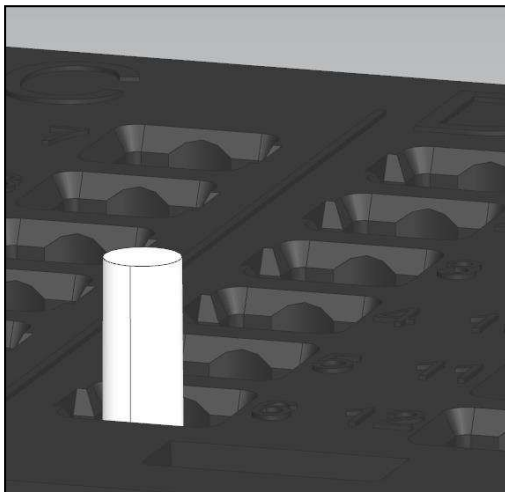
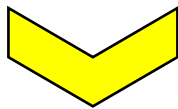
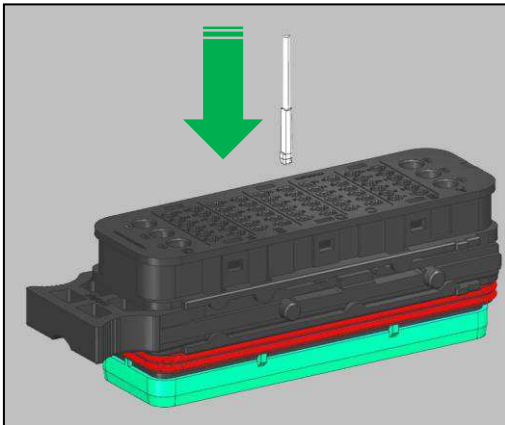

TOP TIP – ONLY FOR SIGNAL BLIND CAVITY PLUGS

If this happens



Tool required

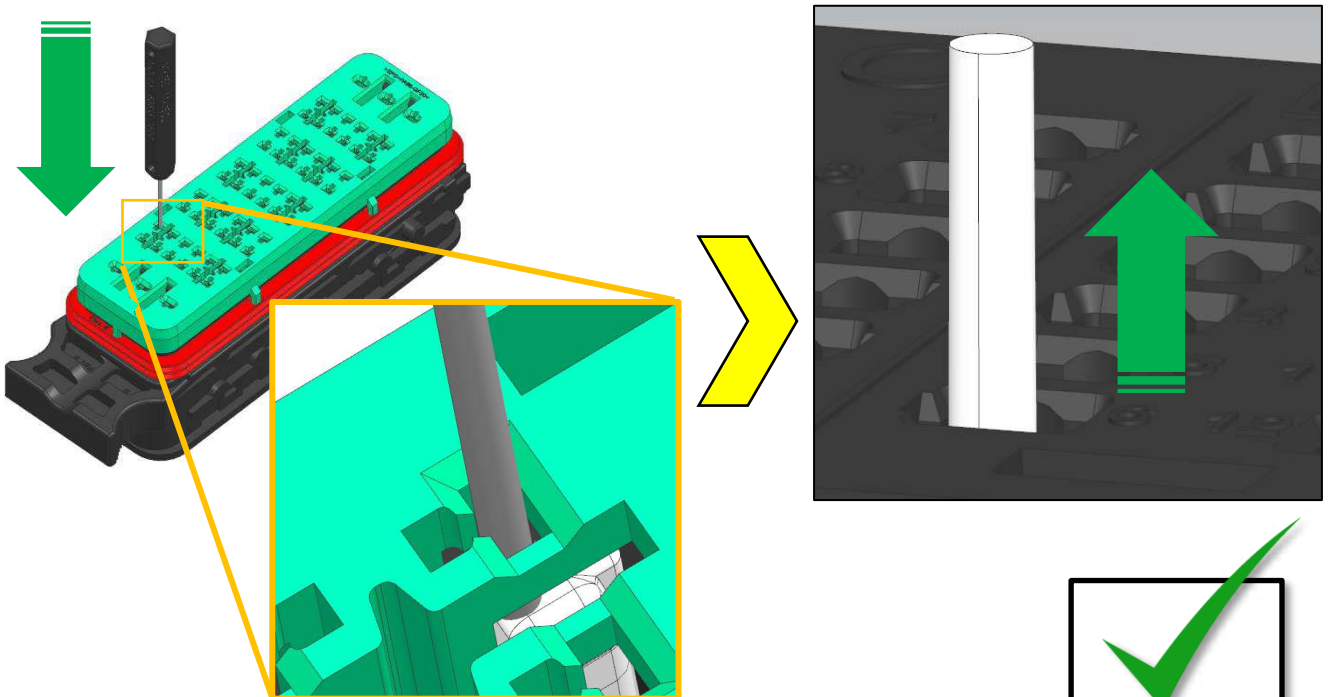
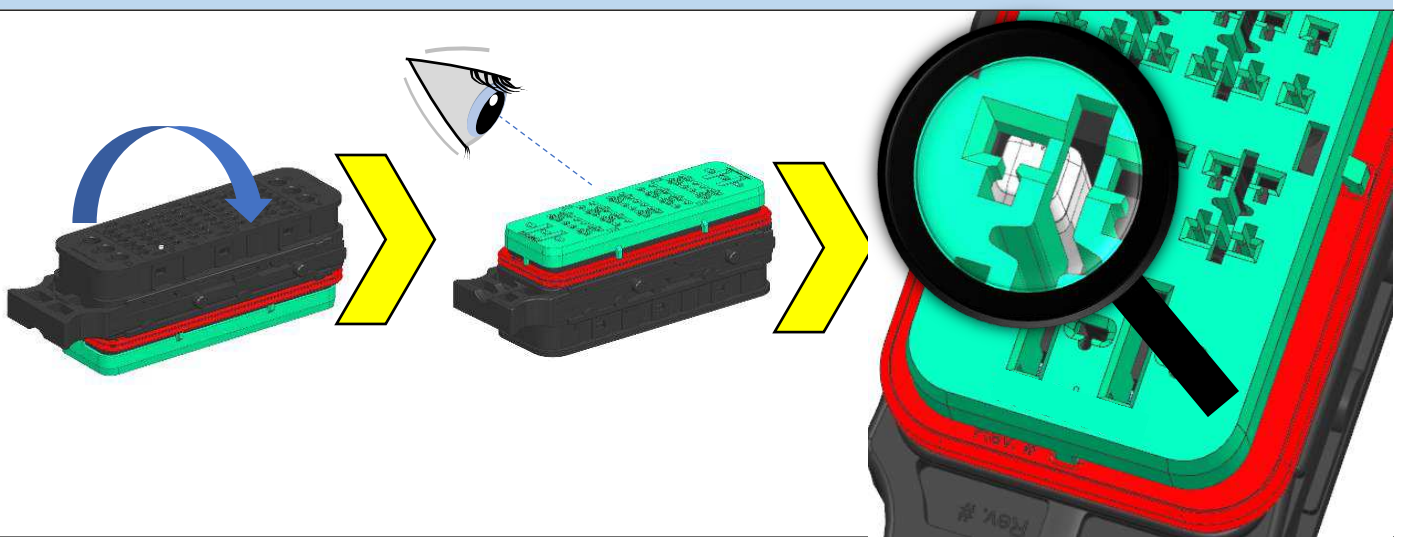

STEP 2.1 – TRIM SIGNAL BLIND CAVITY PLUGS (RECOMMENDED)

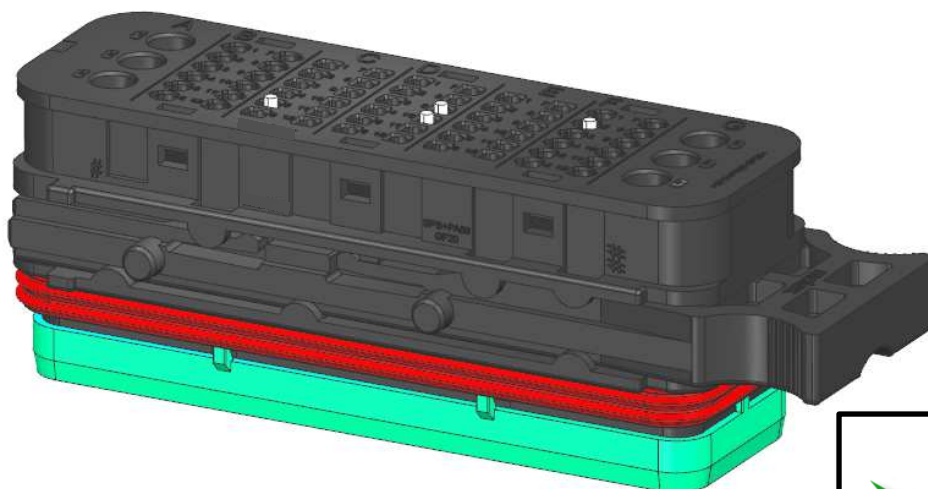
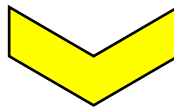
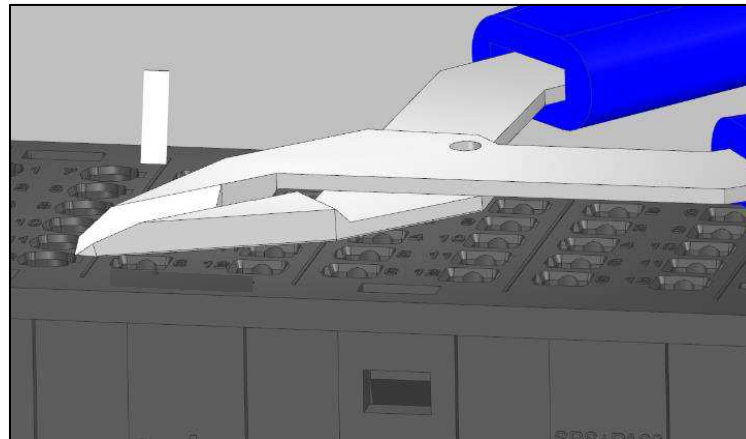
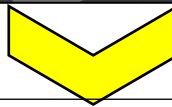
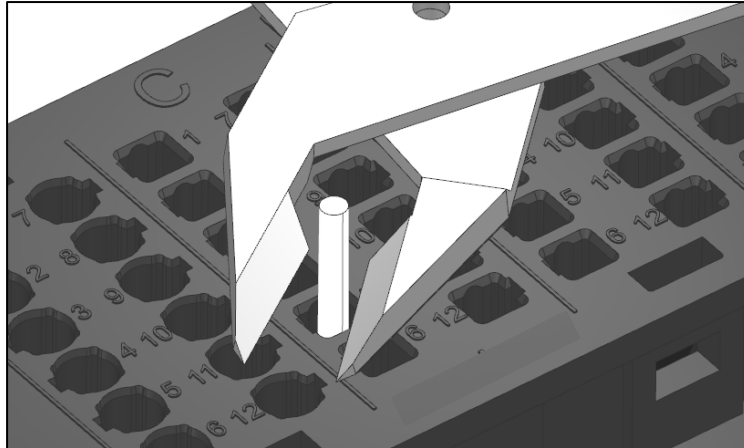
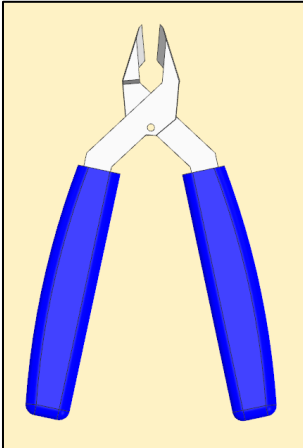

Demonstration example



This specification is a controlled document.

Page 10 of 52

STEP 3 – INSERT POWER BLIND CAVITY PLUGS

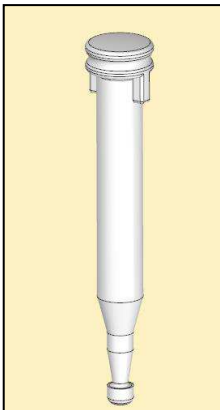

P/N:2500033-1
(Old P/N:
937320001)

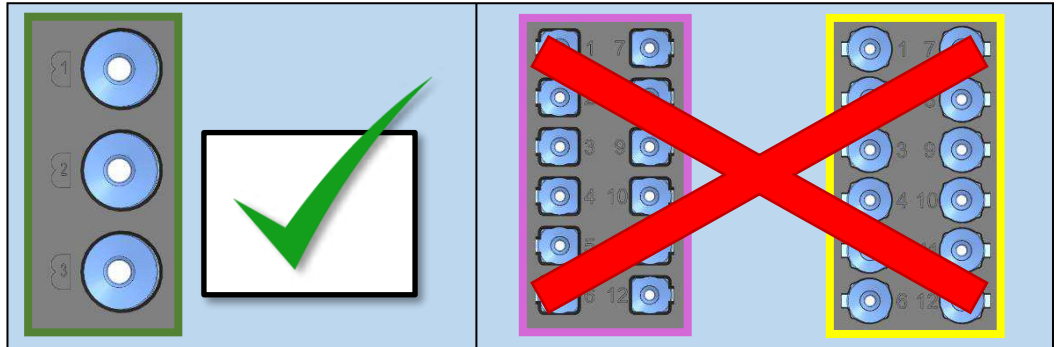

Demonstration example

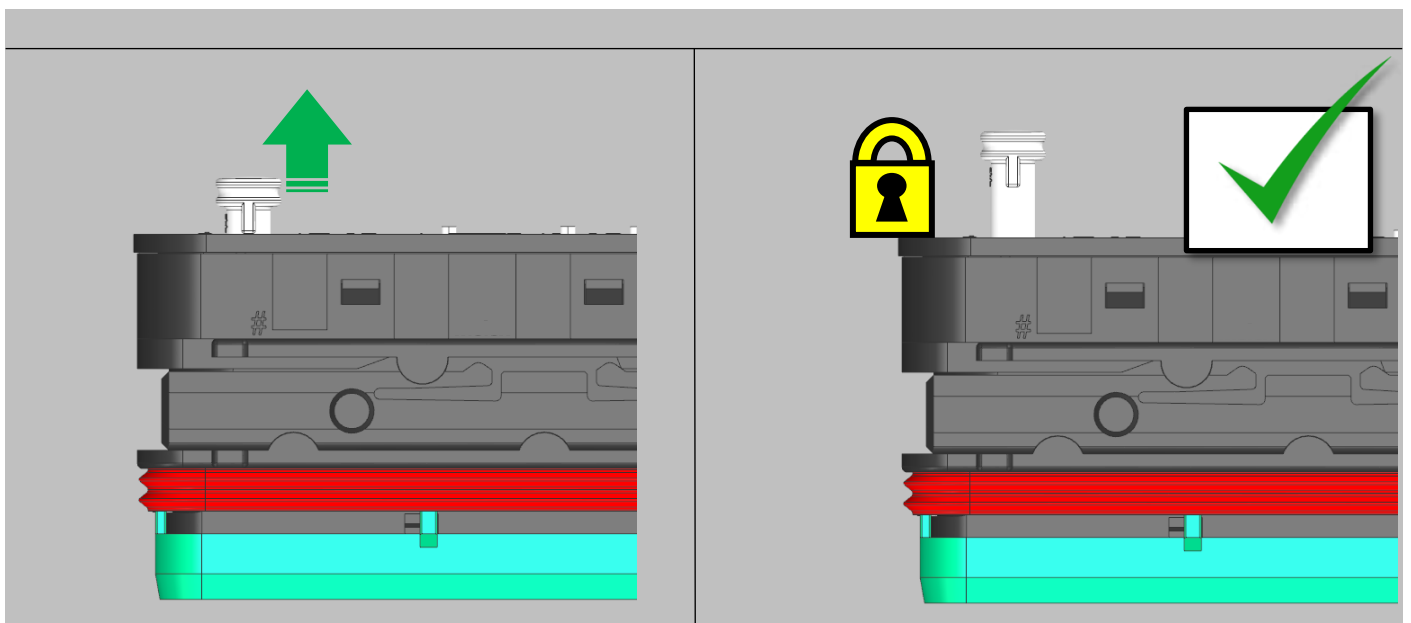
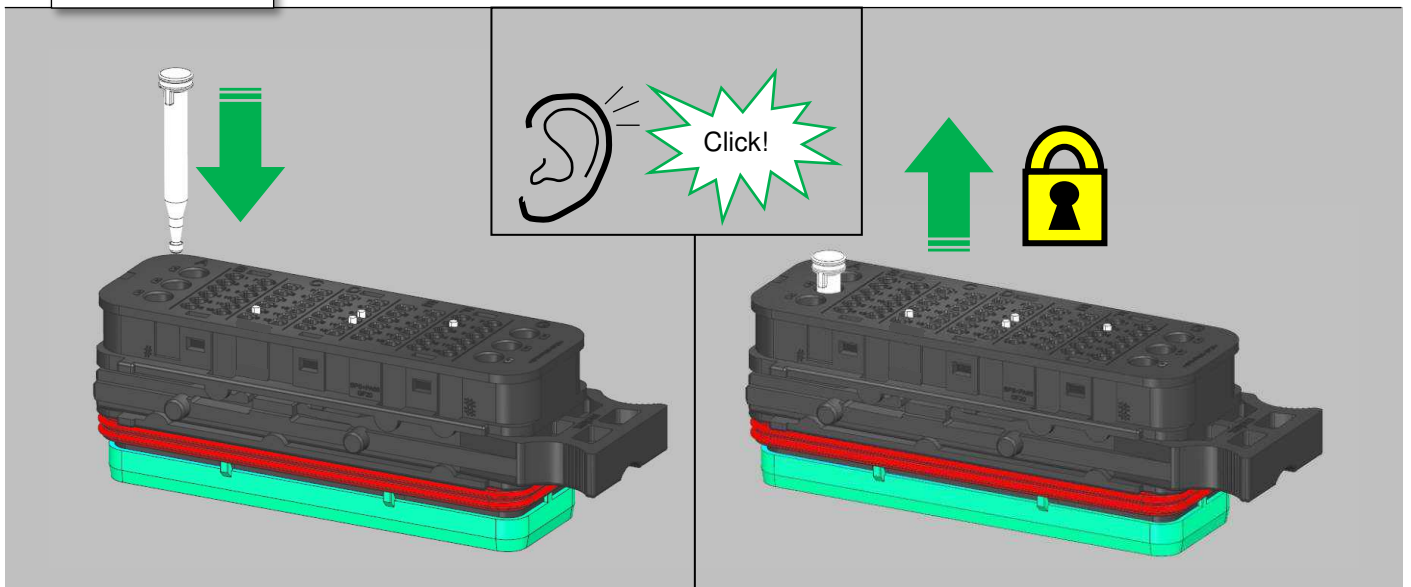

STEP 4 – INSERT SIGNAL TERMINALS

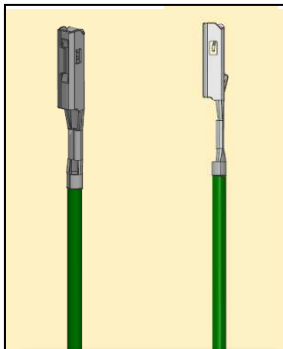

Part no. see sales drawing SD-33012-002

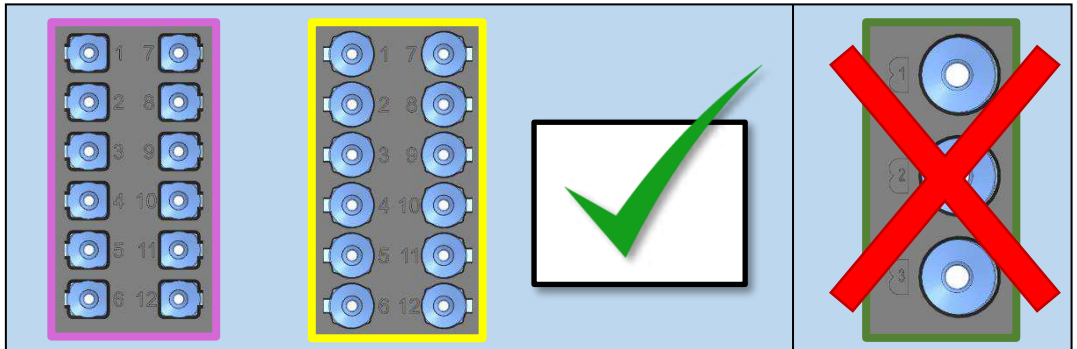

Signal
Cable Insulation Diameter Range 1.5 - 2.7mm

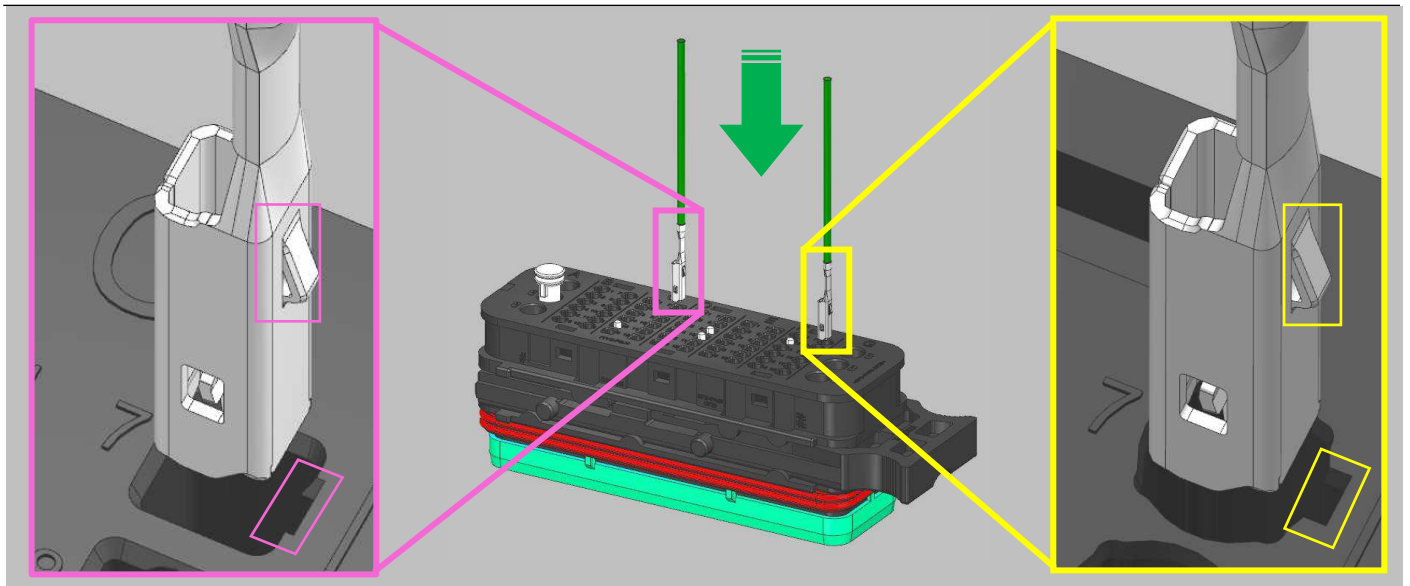

Demonstration example

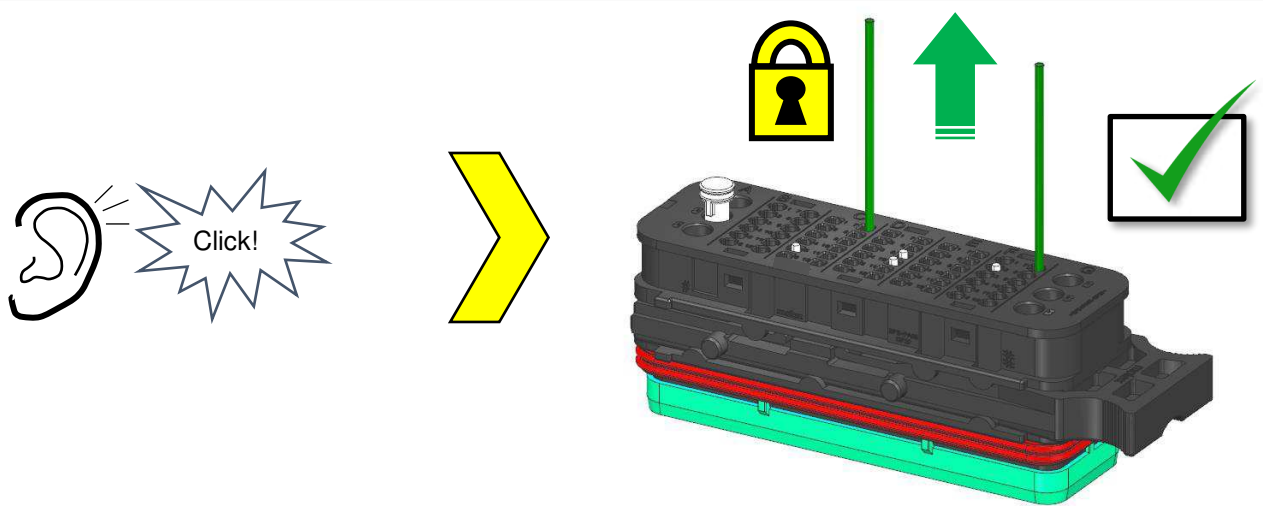

STEP 5 – INSERT 2.5MM² (13AWG) TERMINAL

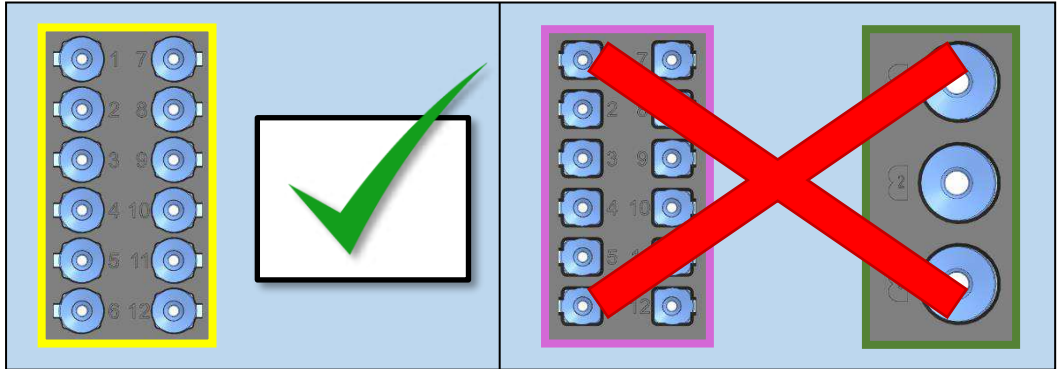
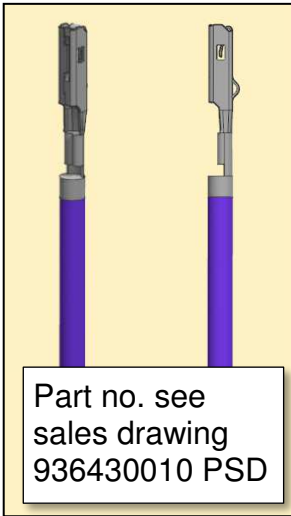

2.5mm²
Cable Insulation Diameter
Range 1.5 – 3.0mm

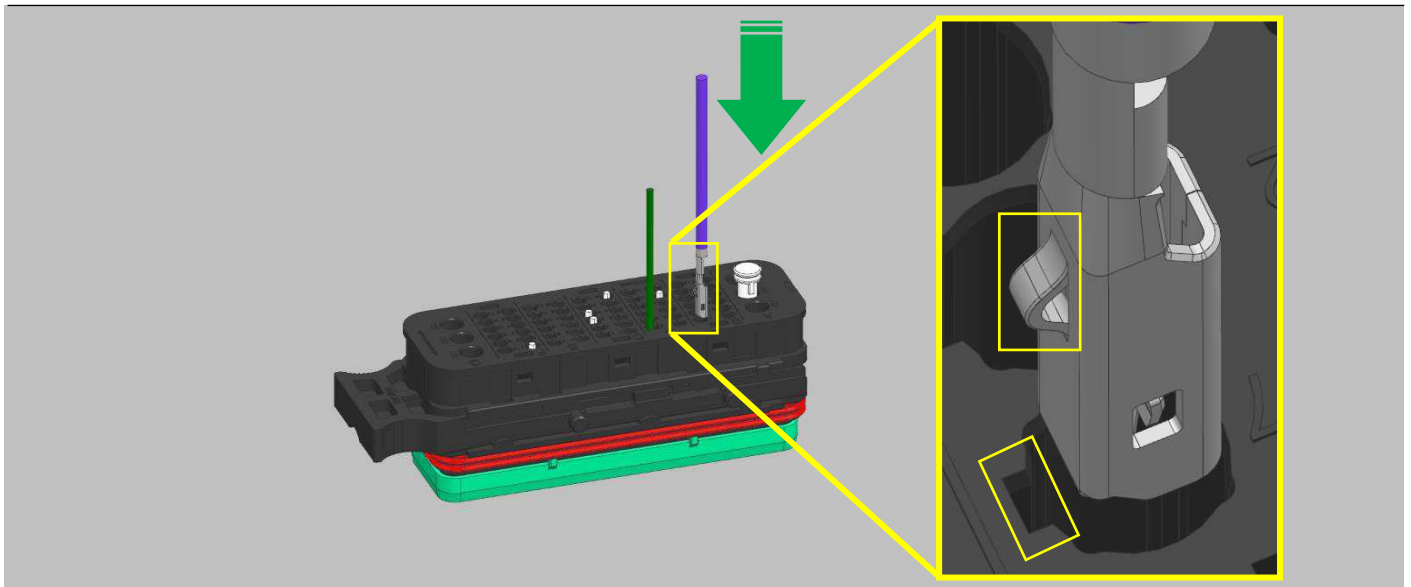

Demonstration example

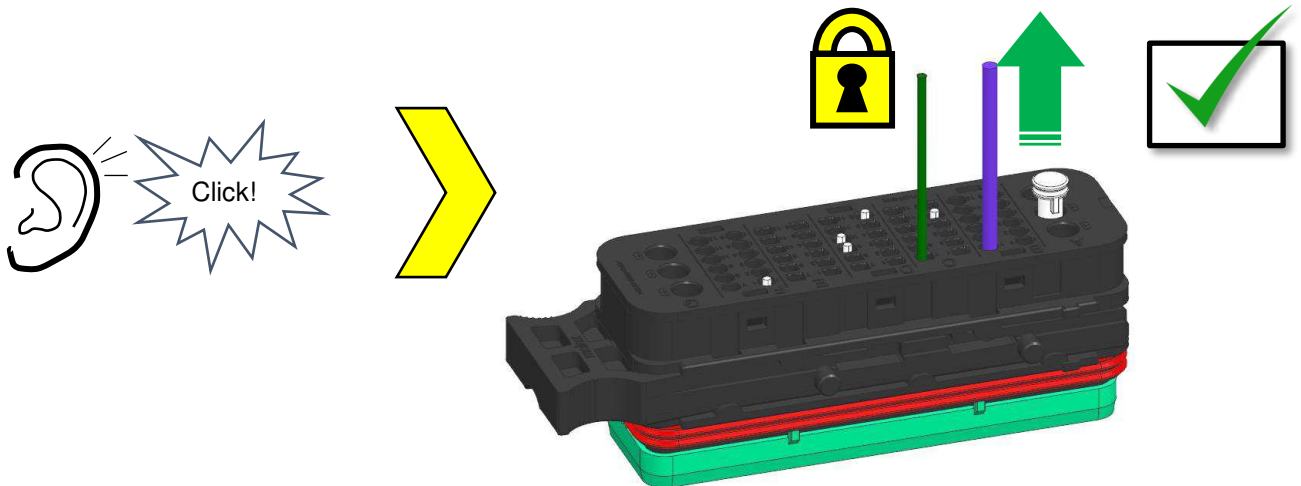

STEP 6 – INSERT POWER TERMINALS

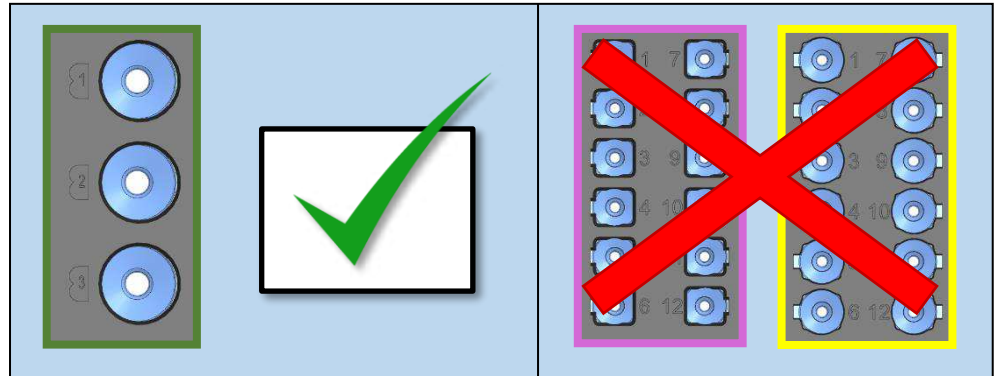
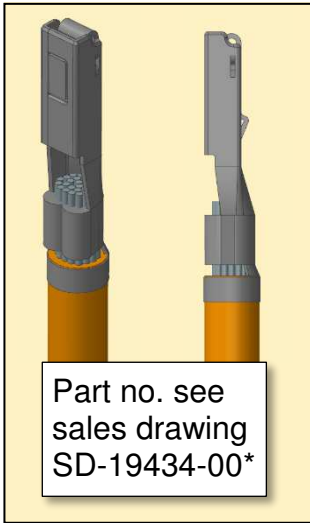

Power
Cable Insulation Diameter
Range 3.0 – 5.0mm



Insert terminal nose carefully through seal opening

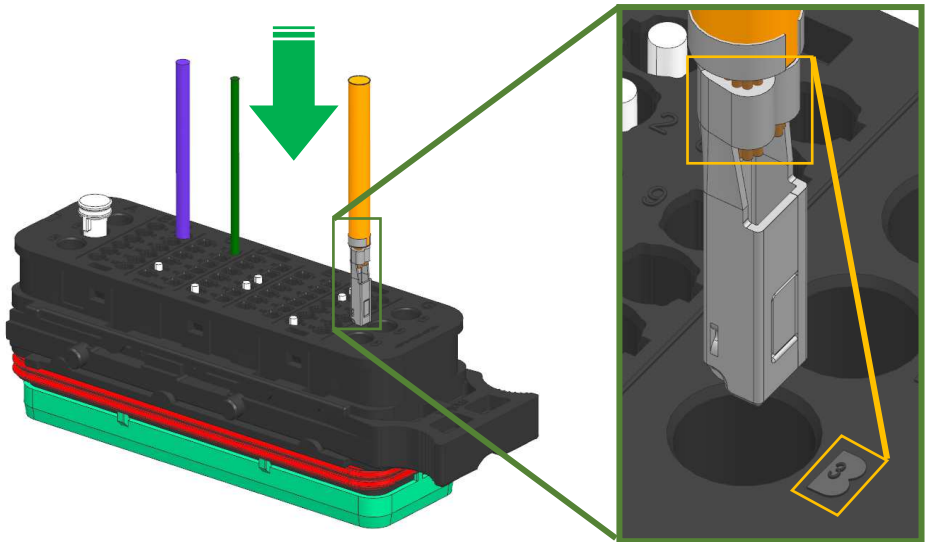

Demonstration example

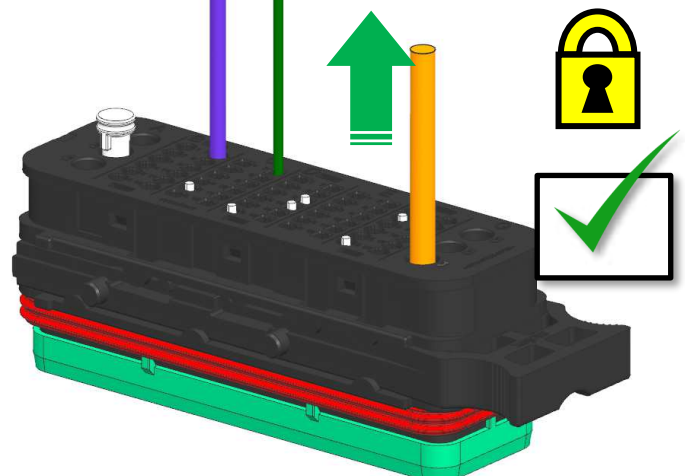
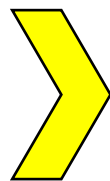

STEP 7 – CLOSE TPA



**Populate connector fully
no holes left empty**

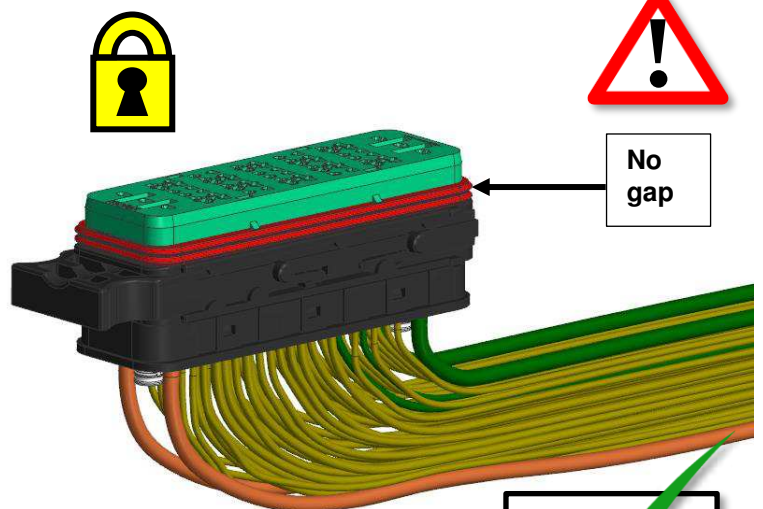
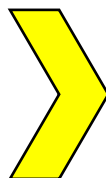
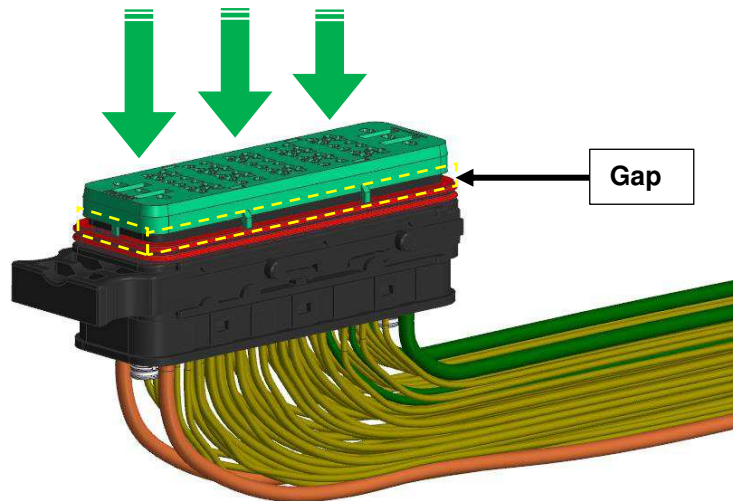
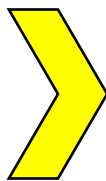
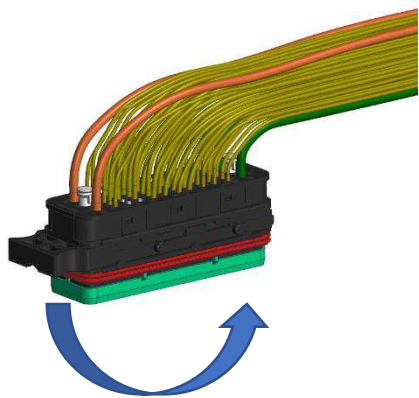
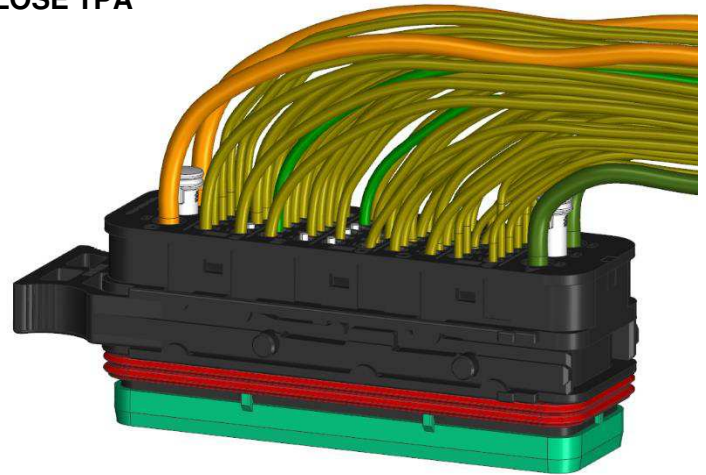

STEP 8 – APPLY WIRE DRESS/CONDUIT INTERFACE



- Various configurations of wire dress available.
 - 1 – 3 open exits
 - 4 different exit sizes
- See sales drawing: 2500034
- Appropriate conduit must be used with wire dress
- Example shown for demonstration only
- Direction of exit(s) per wiring diagram

Tool & parts needed

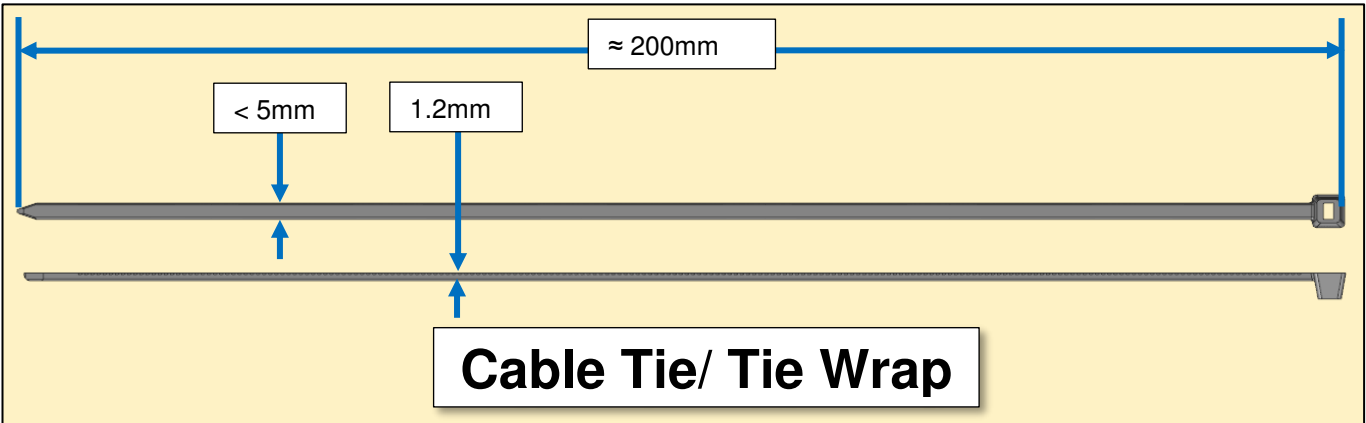
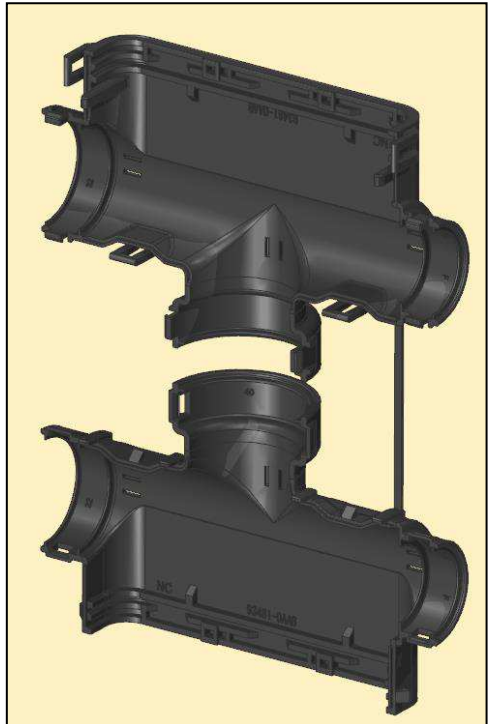
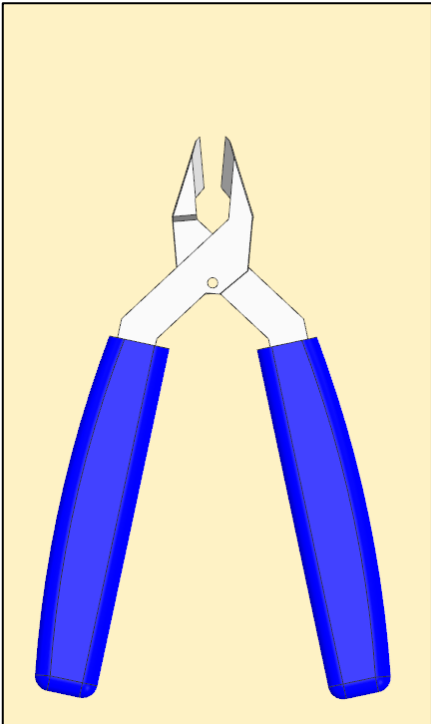

RECOMMENDED ASSEMBLY SEQUENCE

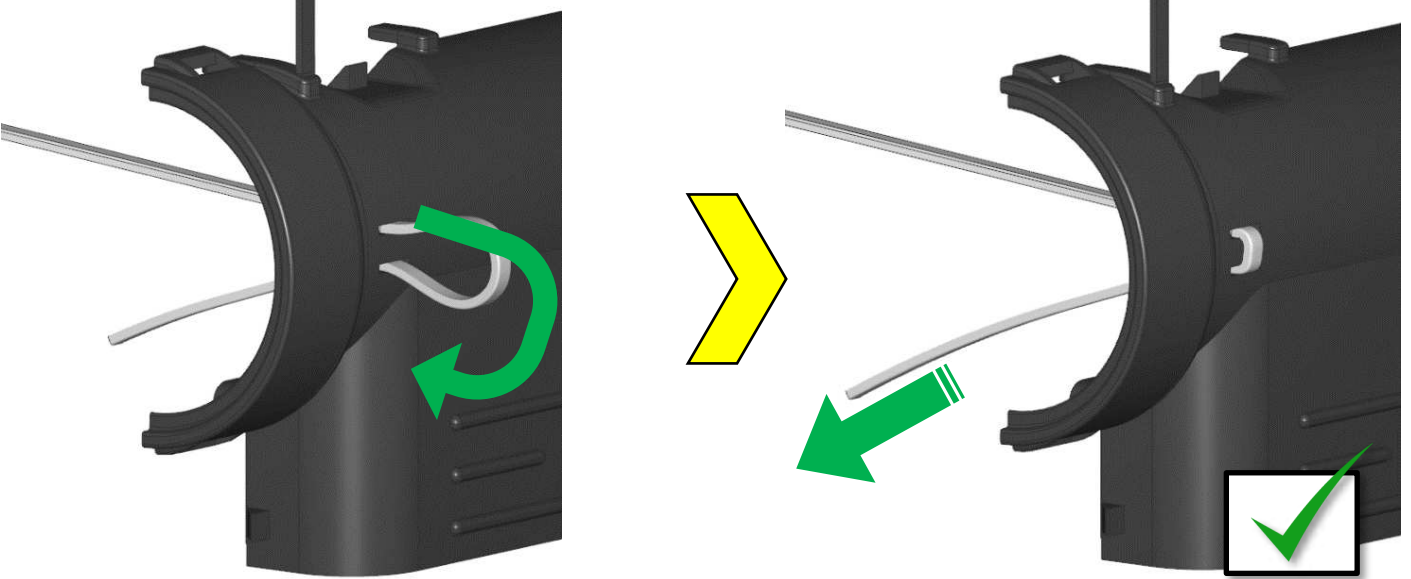
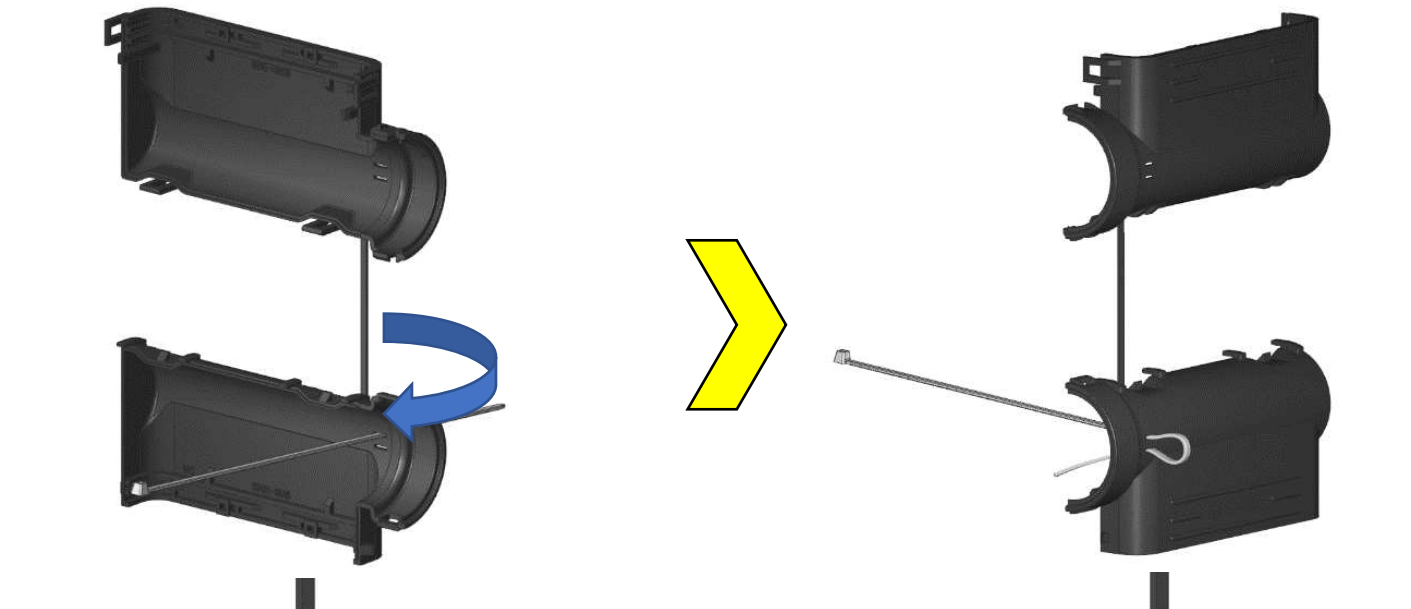
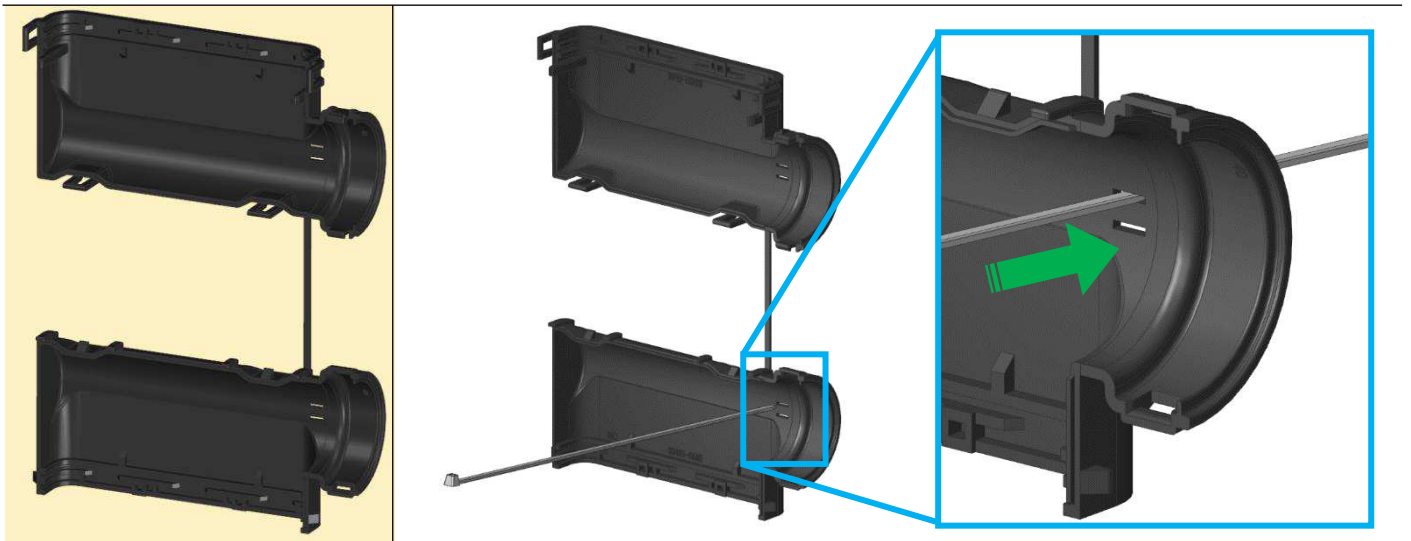

RECOMMENDED ASSEMBLY SEQUENCE

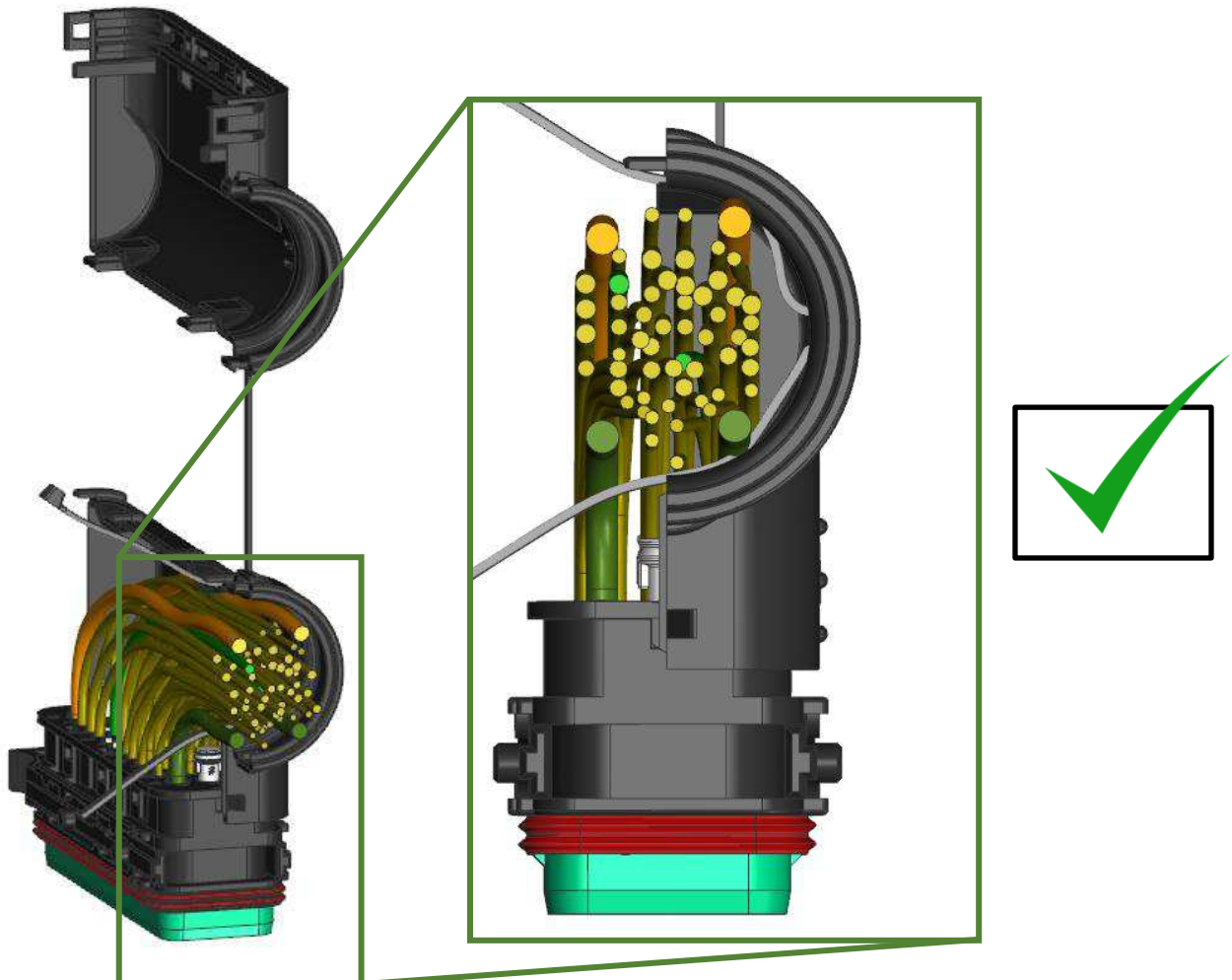
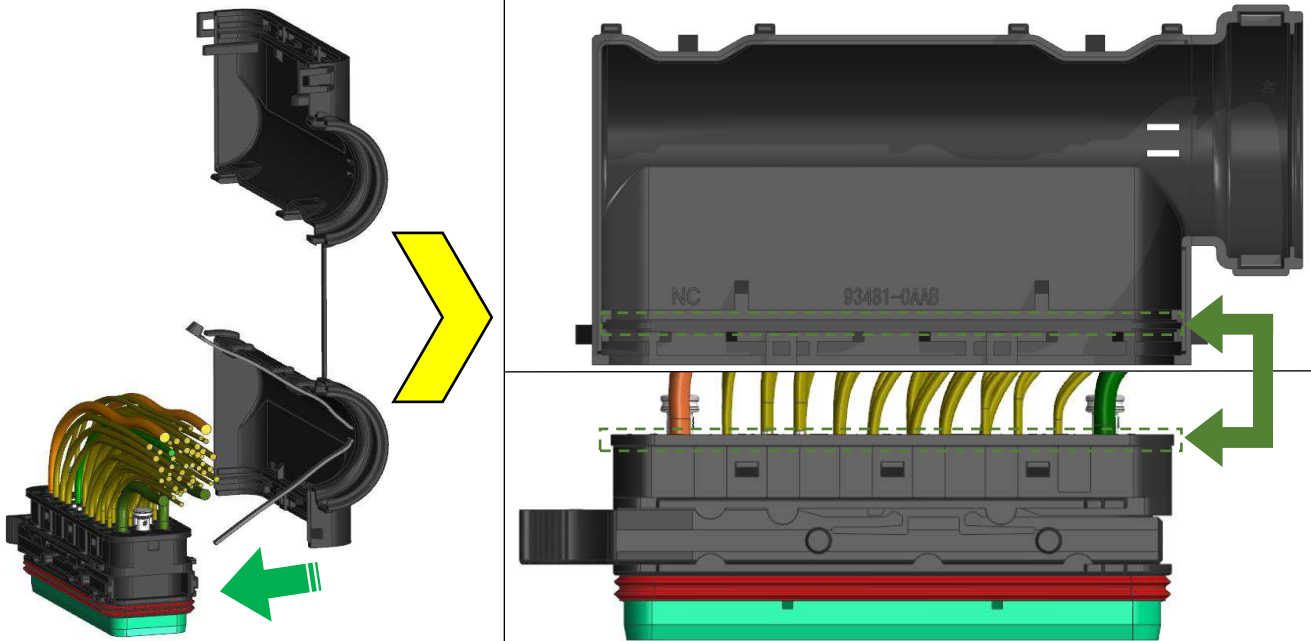

RECOMMENDED ASSEMBLY SEQUENCE

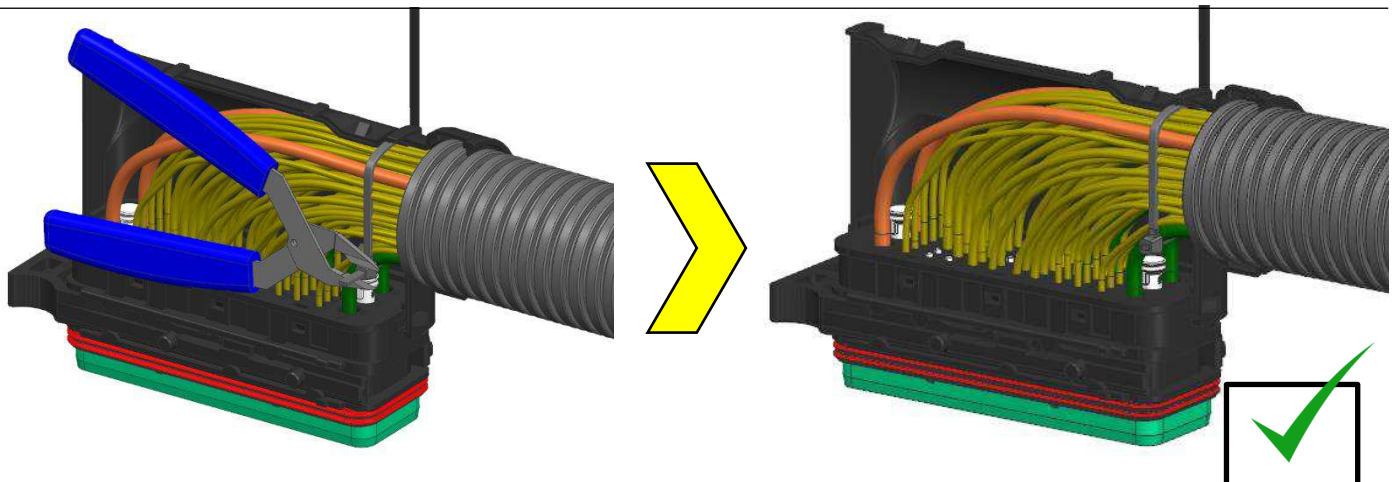
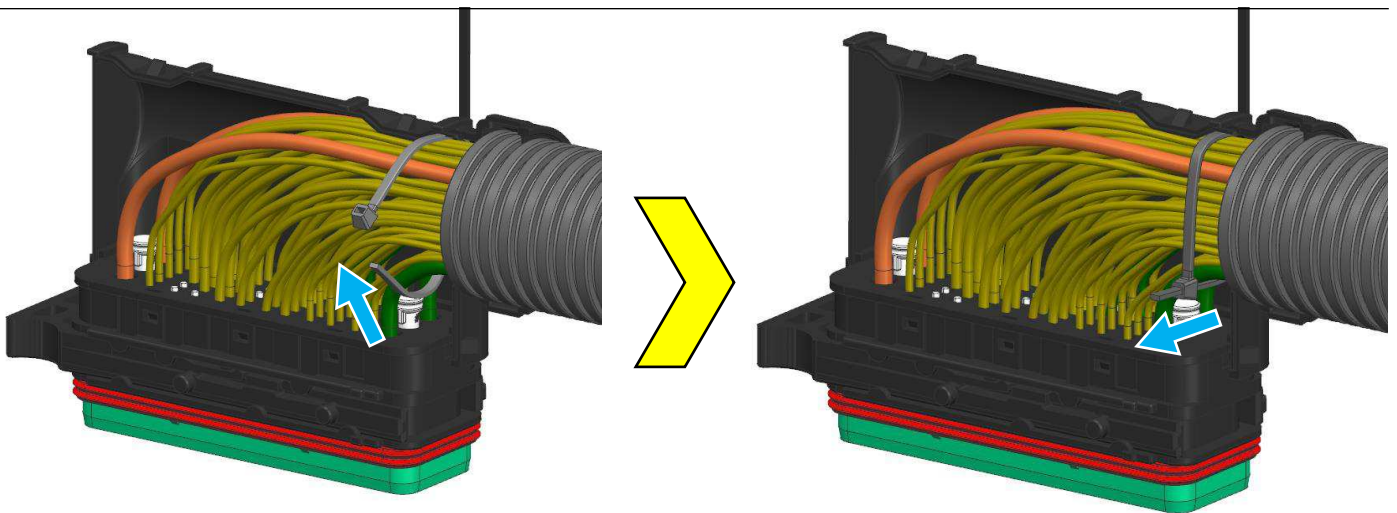
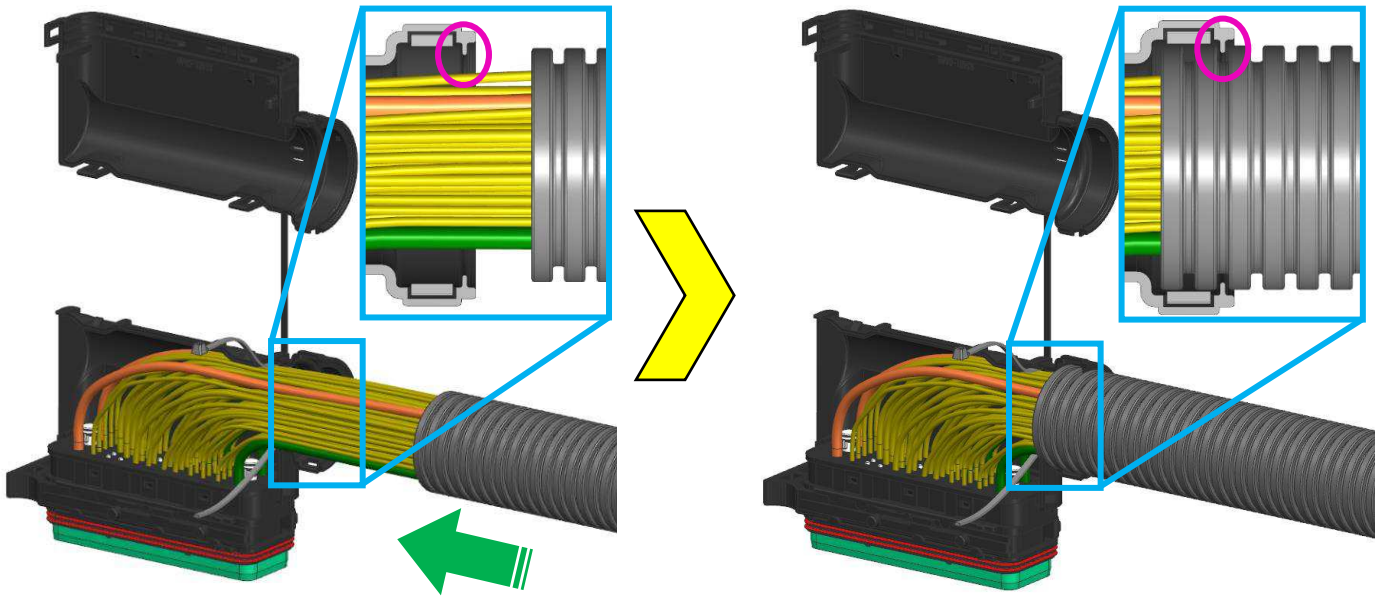

RECOMMENDED ASSEMBLY SEQUENCE

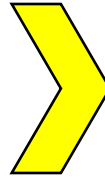
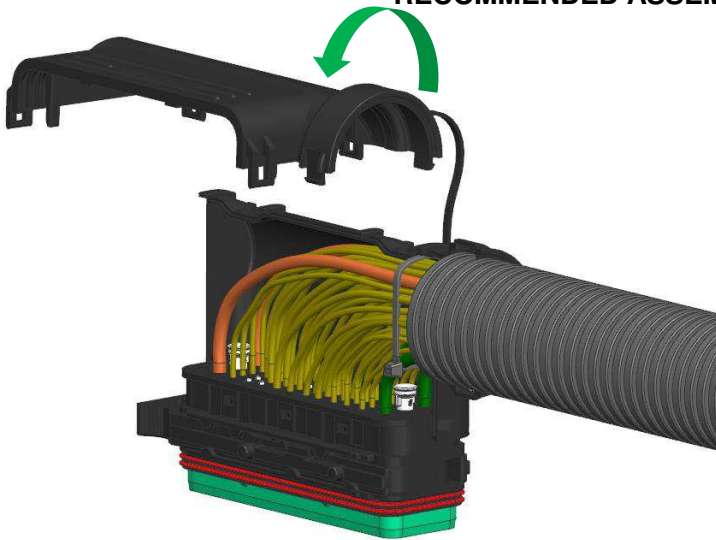

OR

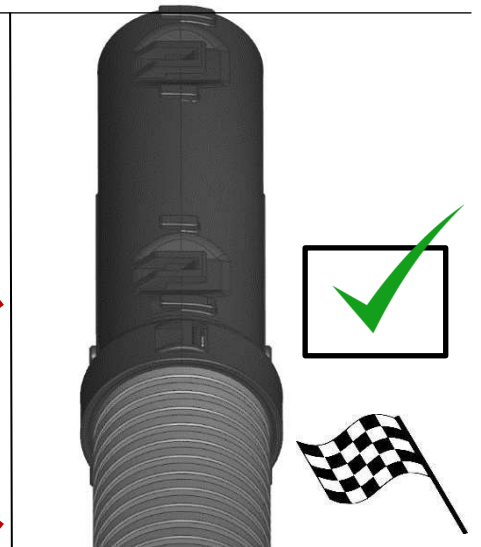
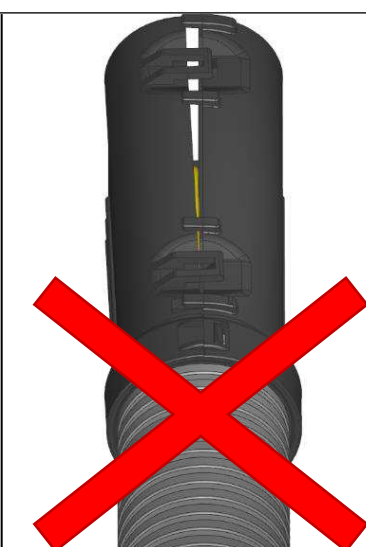
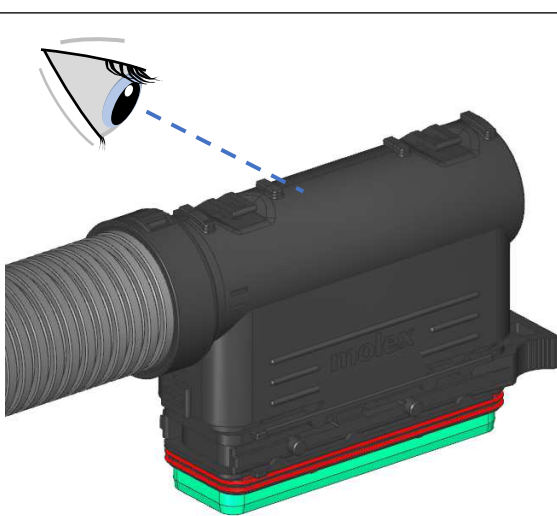
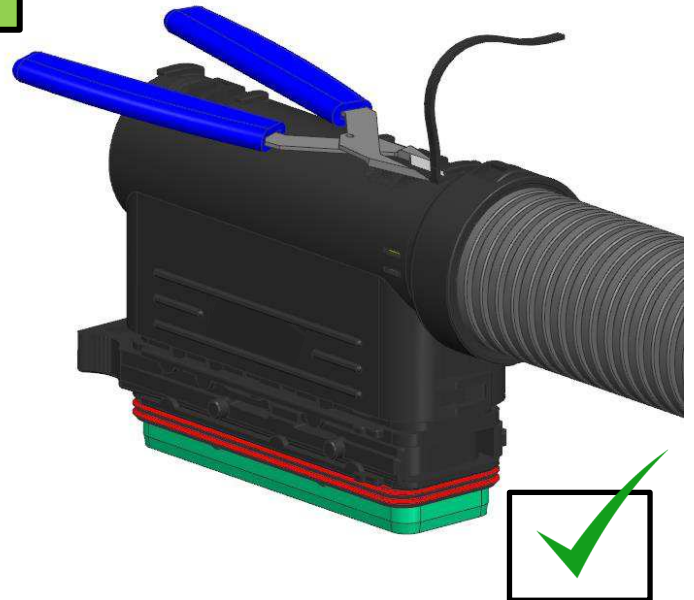
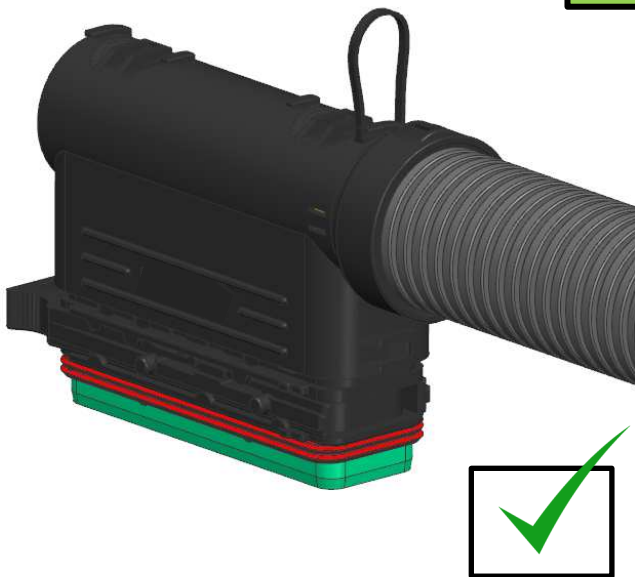

MALE ASSEMBLY OVERVIEW

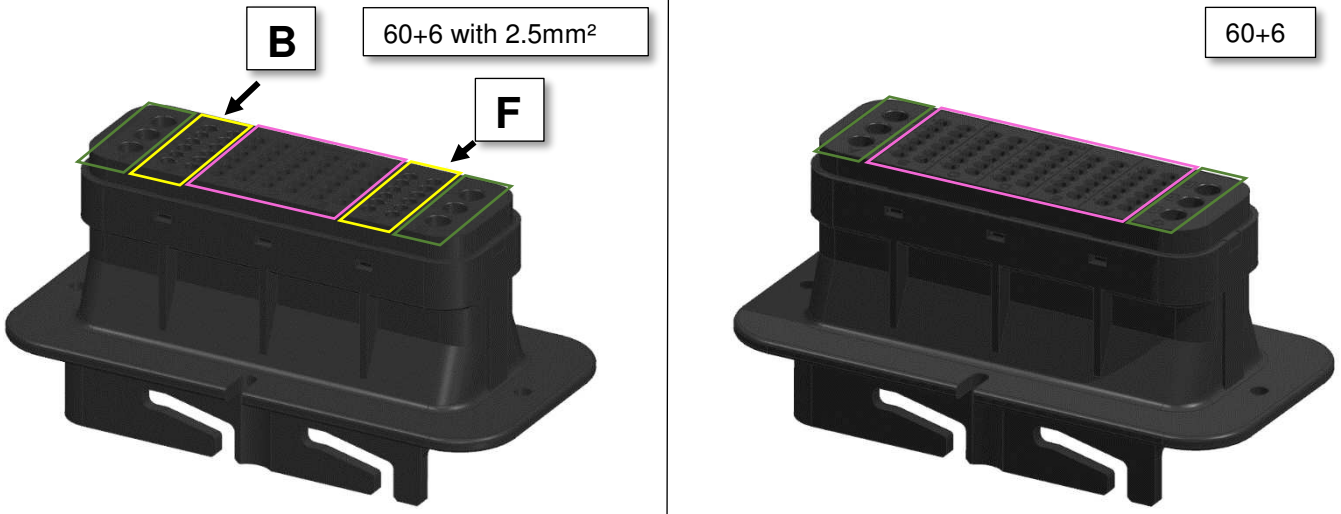

- 2.5mm² only available on some configurations and only in **B and F** locations as highlighted in yellow above
- For all configurations please see 2500016 thru 2500031

| Signal | 2.5mm ² | Power |
|--|---|---|
| | | |
| <p>Signal Cable Insulation Diameter Range 1.5 - 2.7mm</p> | <p>2.5mm² Cable Insulation Diameter Range 1.5 – 3.0mm</p> | <p>Power Cable Insulation Diameter Range 3.0 – 5.0mm</p> |

STEP 1 – OPEN TPA

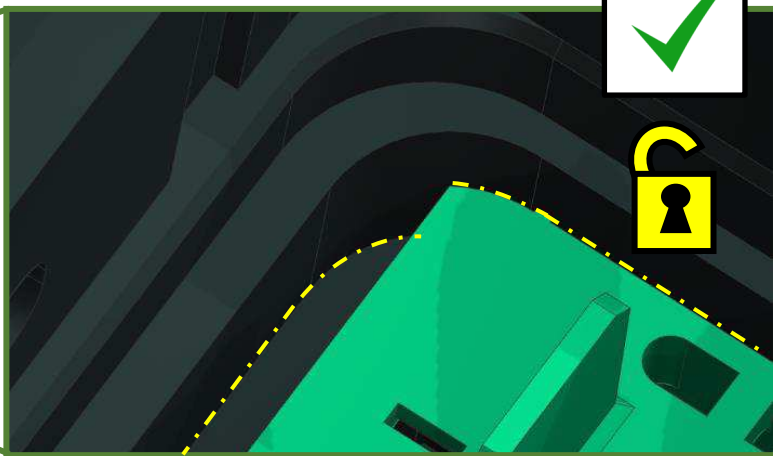
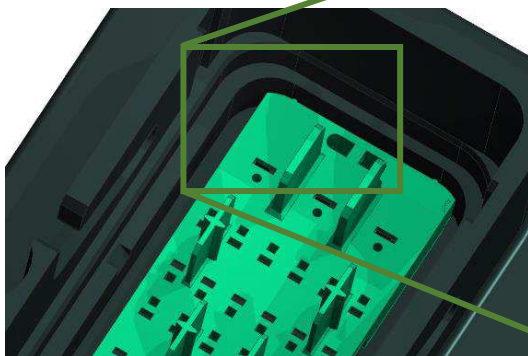
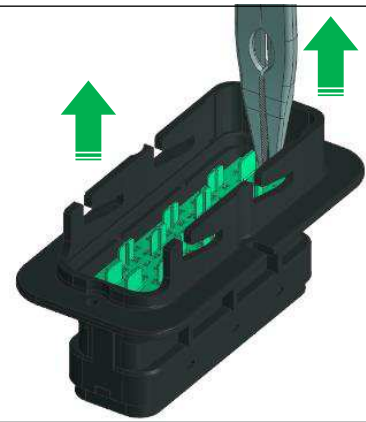
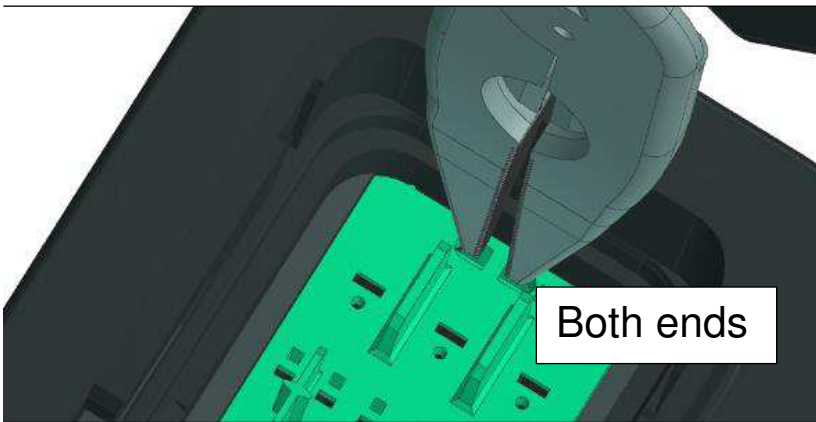
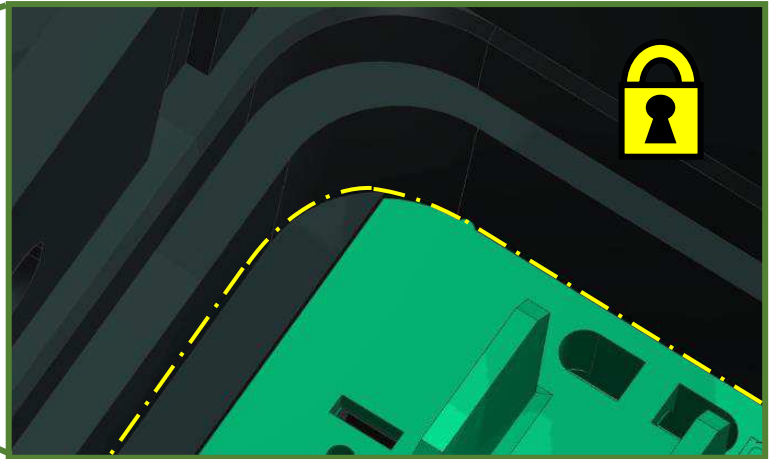
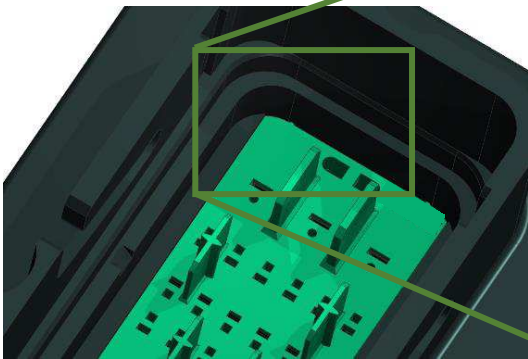
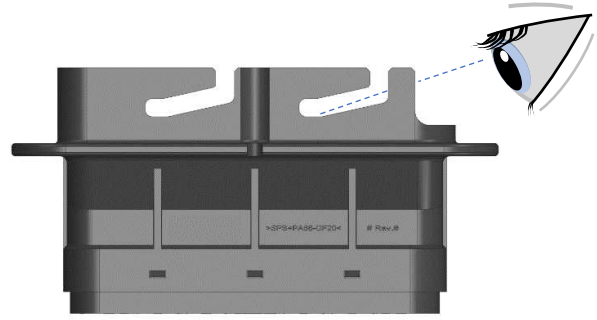
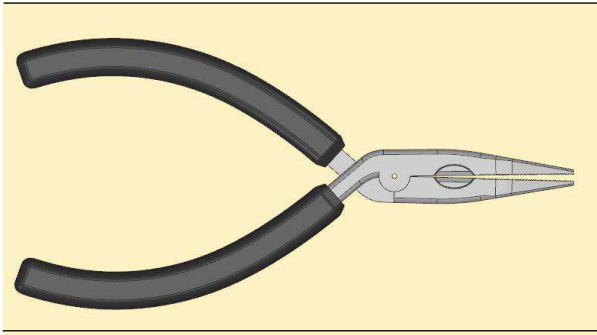

STEP 2 – INSERT SIGNAL BLIND CAVITY PLUGS

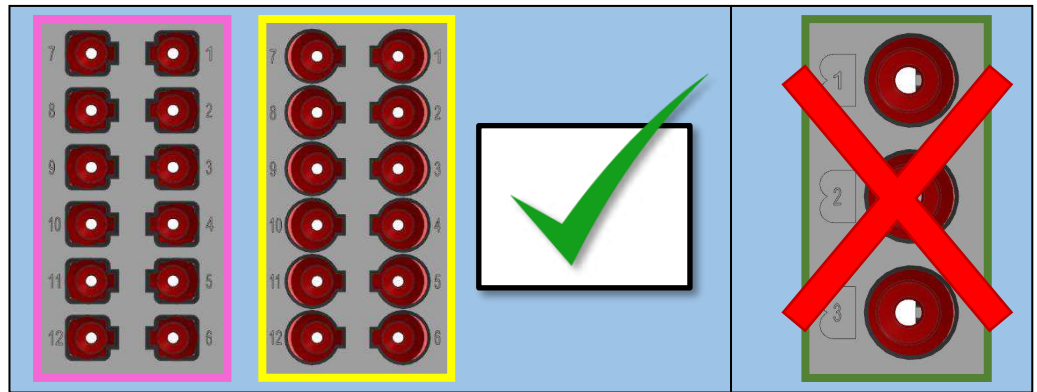
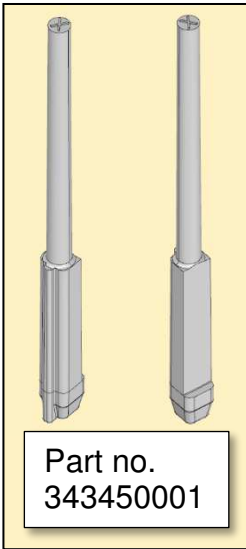

Demonstration example

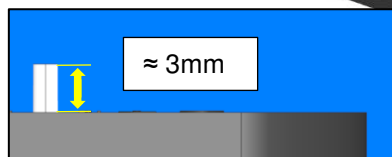
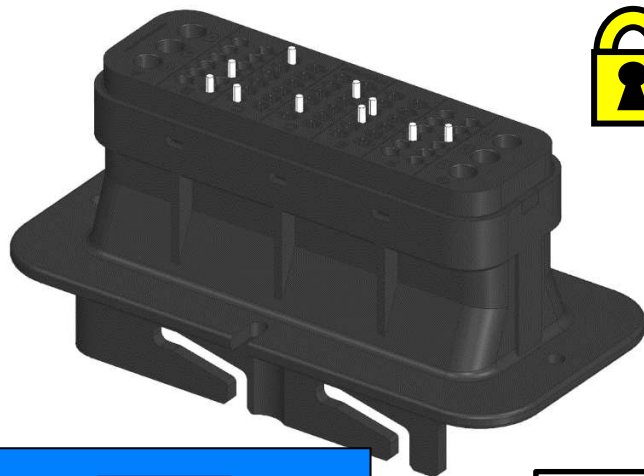
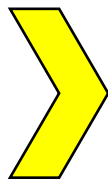
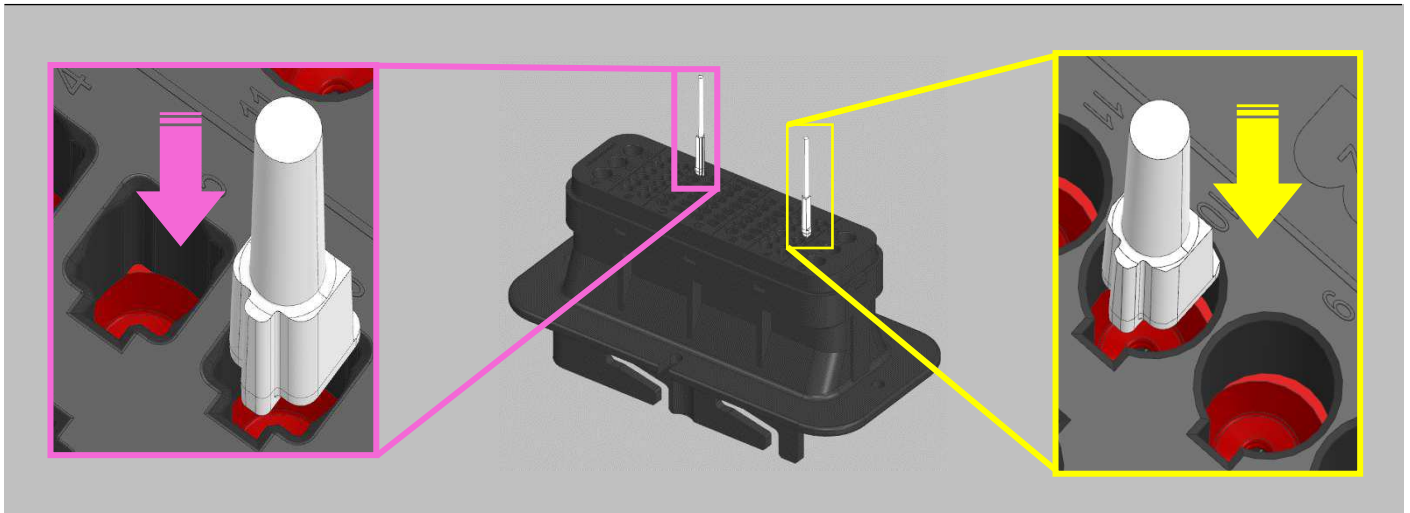

STEP 2.1 – TRIM SIGNAL BLIND CAVITY PLUGS (RECOMMENDED)

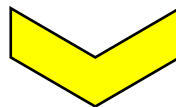
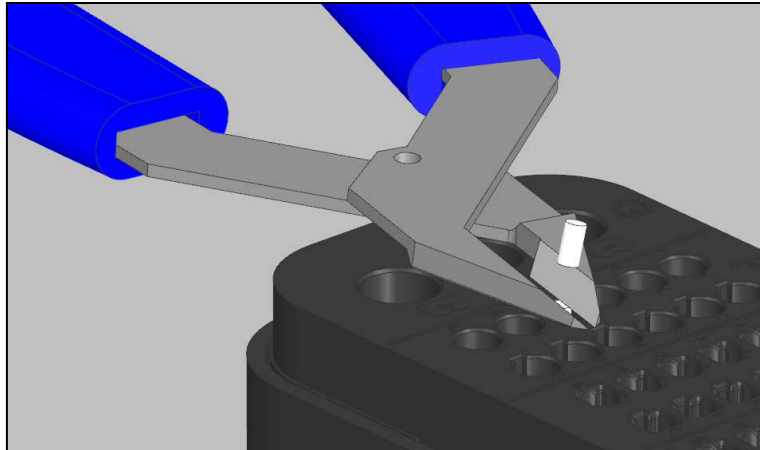
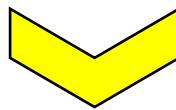
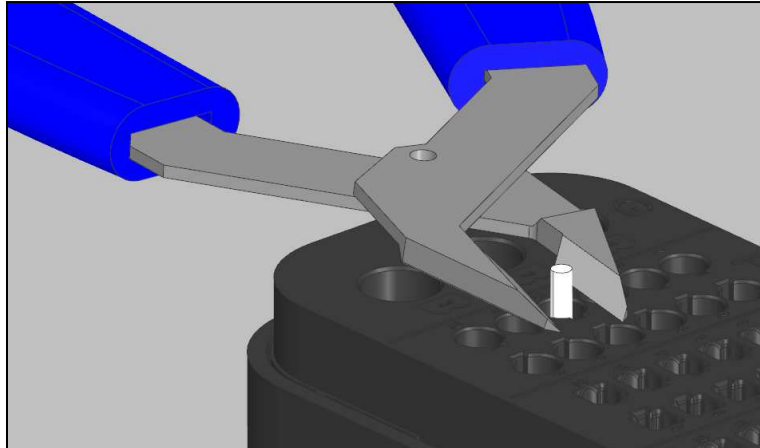
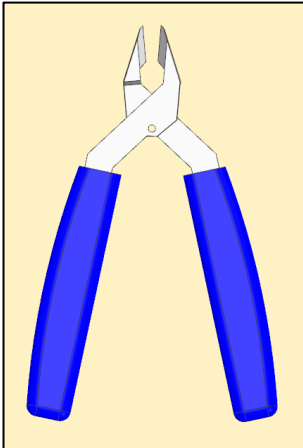

Demonstration example

STEP 3 – INSERT POWER BLIND CAVITY PLUGS

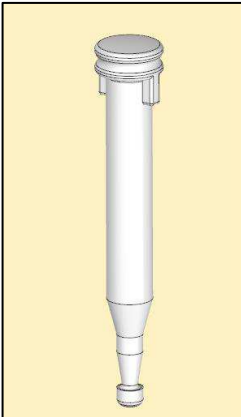

P/N:2500033-1
(Old P/N:
937320001)

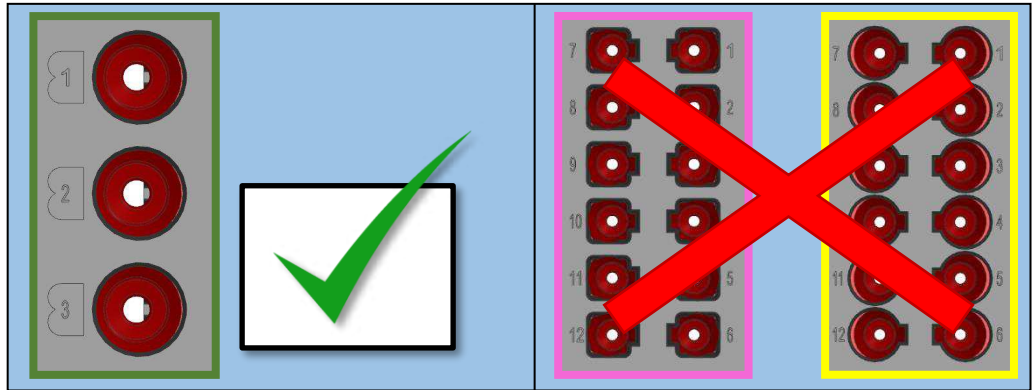

Demonstration example

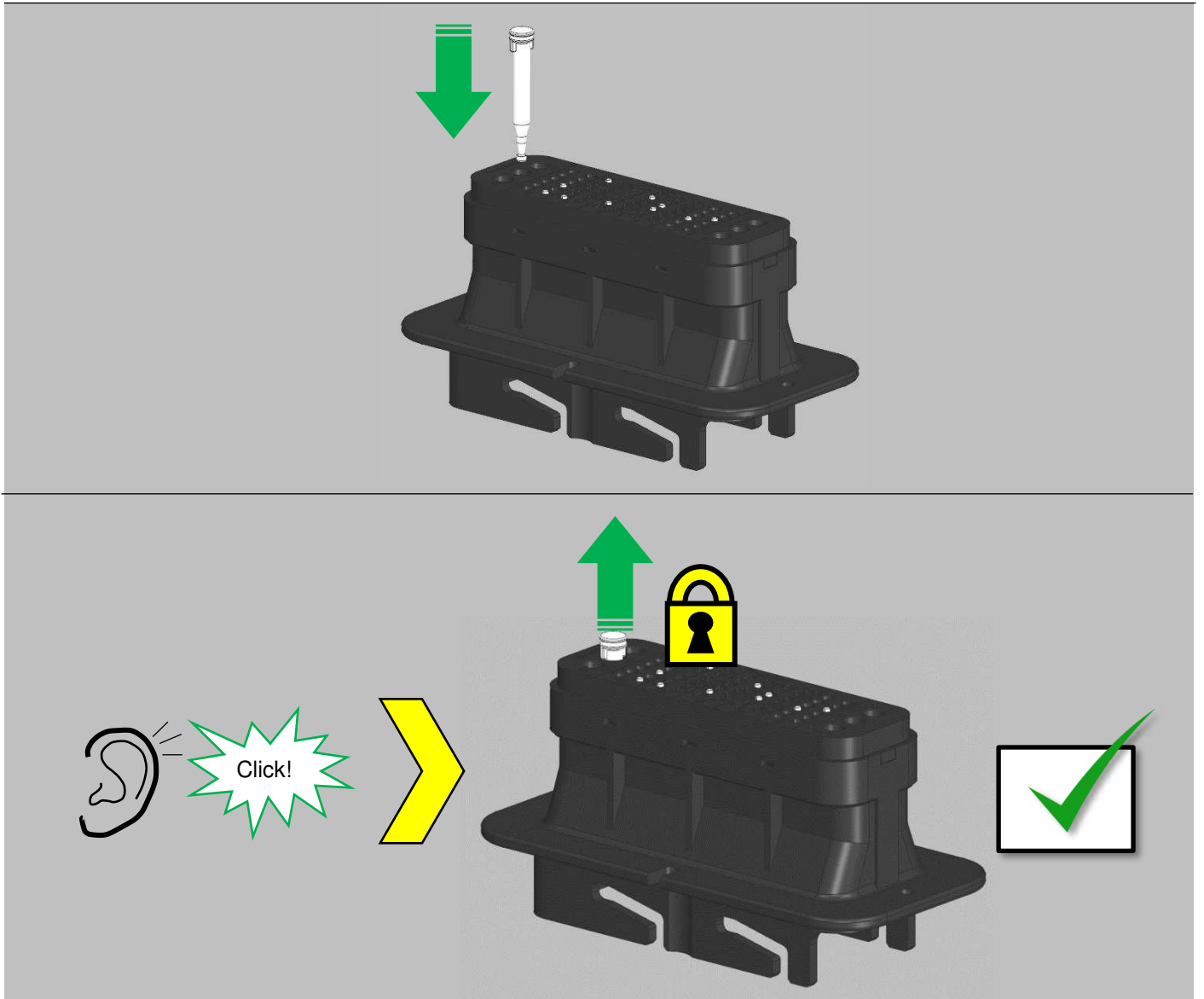

STEP 4 – INSERT SIGNAL TERMINALS

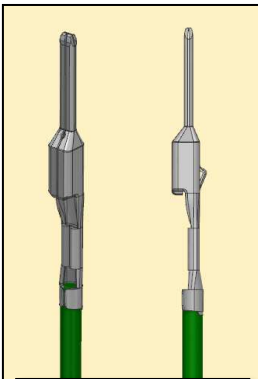

Part no. see sales drawing SD-33000-001

Signal

Cable Insulation Diameter Range 1.5 - 2.7mm

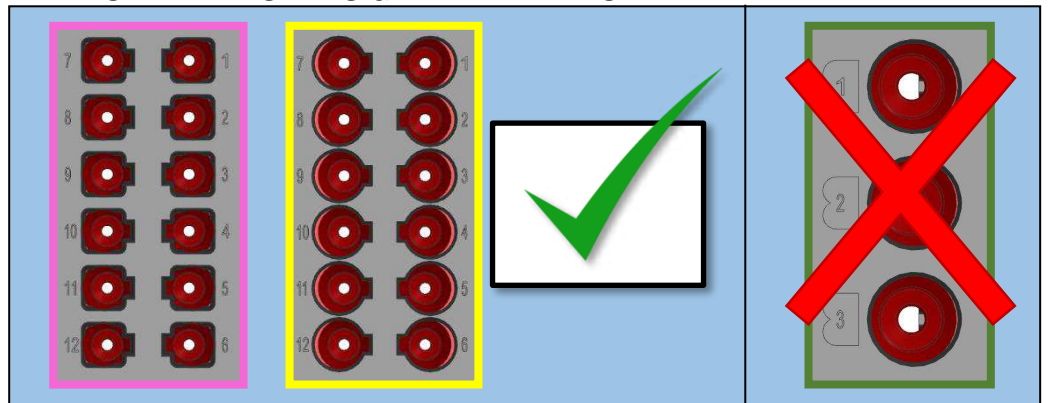

Important:

- Hold cable while putting in male terminals
- Insert terminals 90° to the rear cover
- Insert terminal nose carefully through seal opening

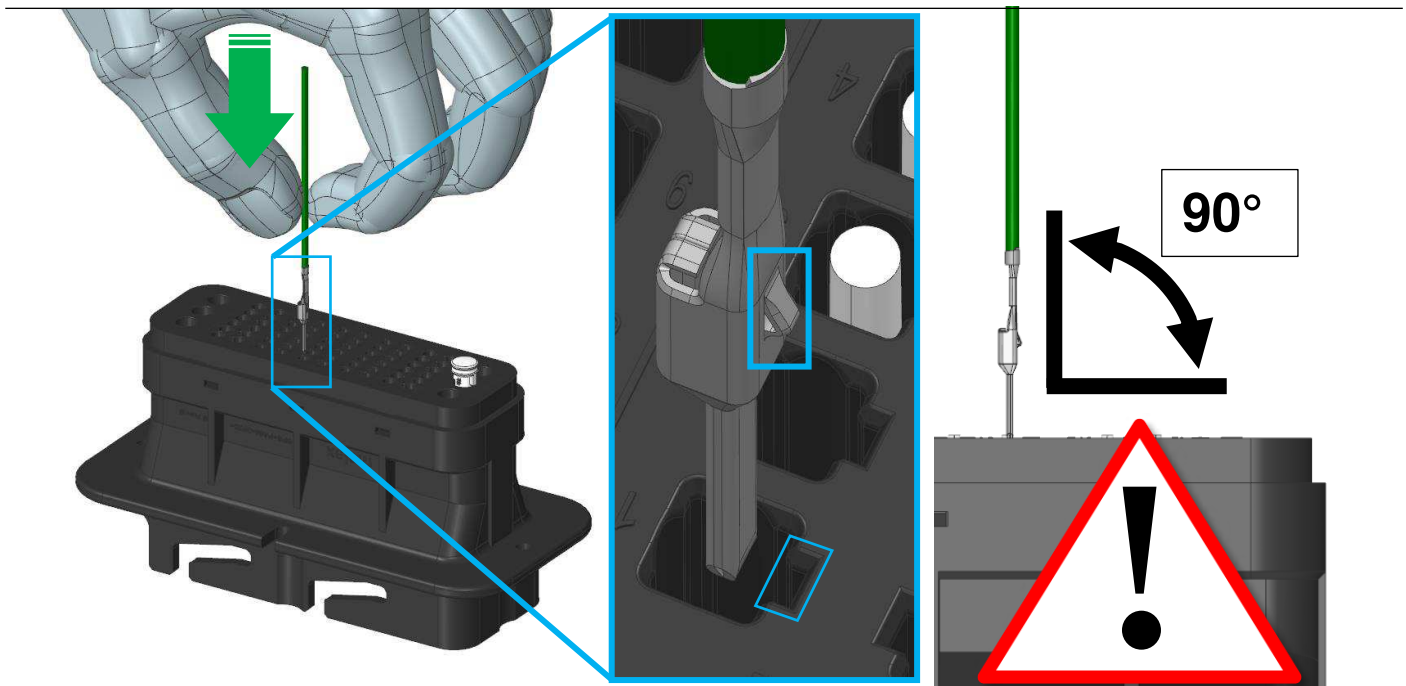

Demonstration example

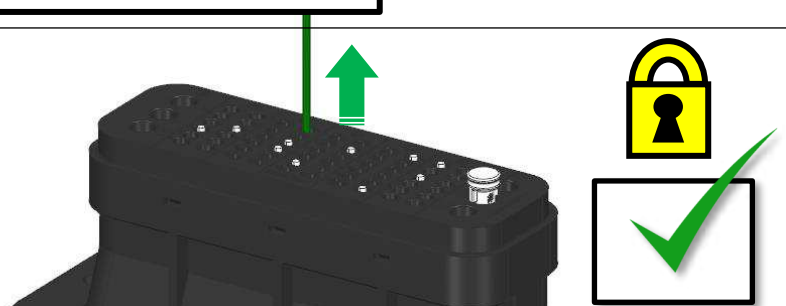
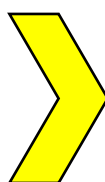

STEP 5 – INSERT 2.5MM² TERMINALS

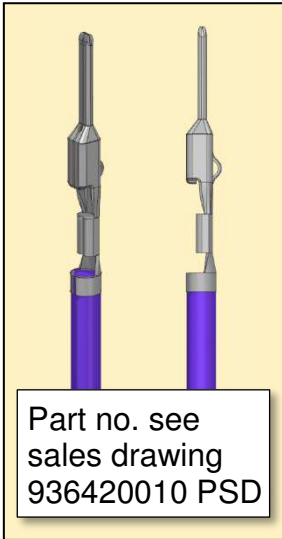

Part no. see sales drawing 936420010 PSD

2.5mm²
Cable Insulation Diameter
Range 1.5 – 3.0mm

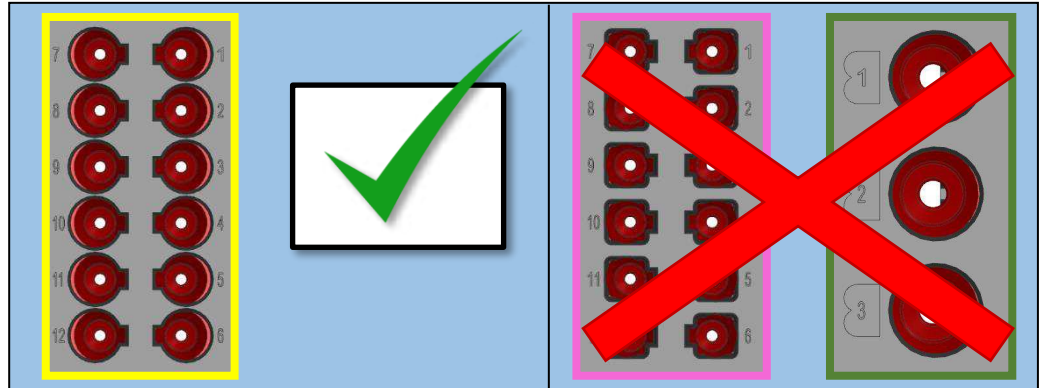

Important:

- Hold cable while putting in male terminals
- Insert terminals 90° to the rear cover
- Insert terminal nose carefully through seal opening

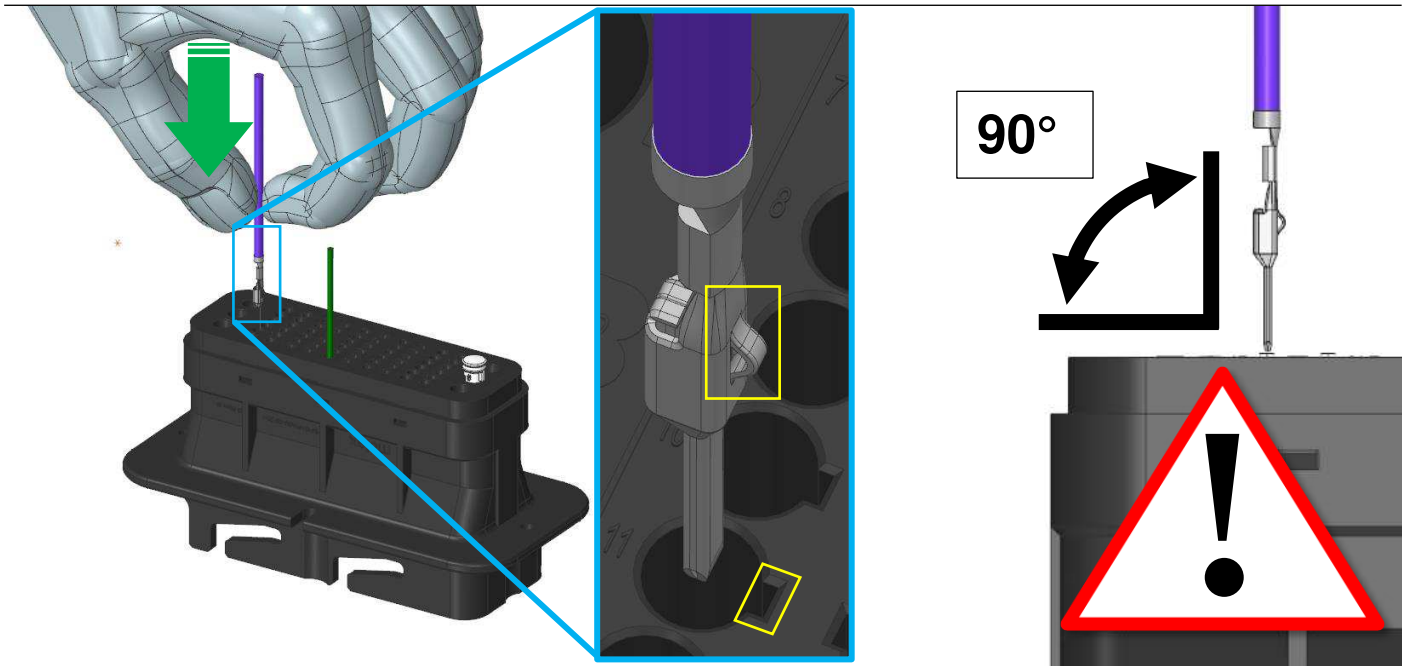

Demonstration example

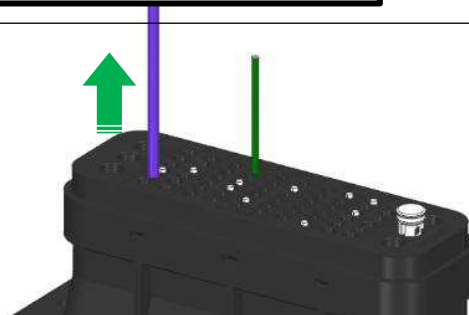
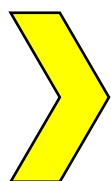

STEP 6 – INSERT POWER TERMINALS

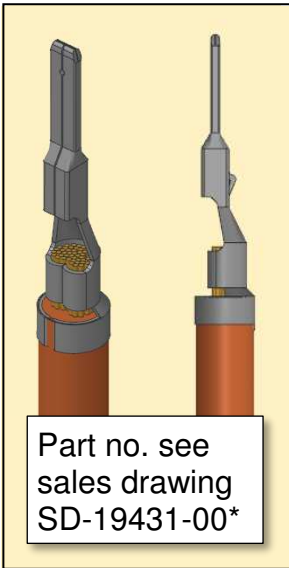

Part no. see sales drawing SD-19431-00*

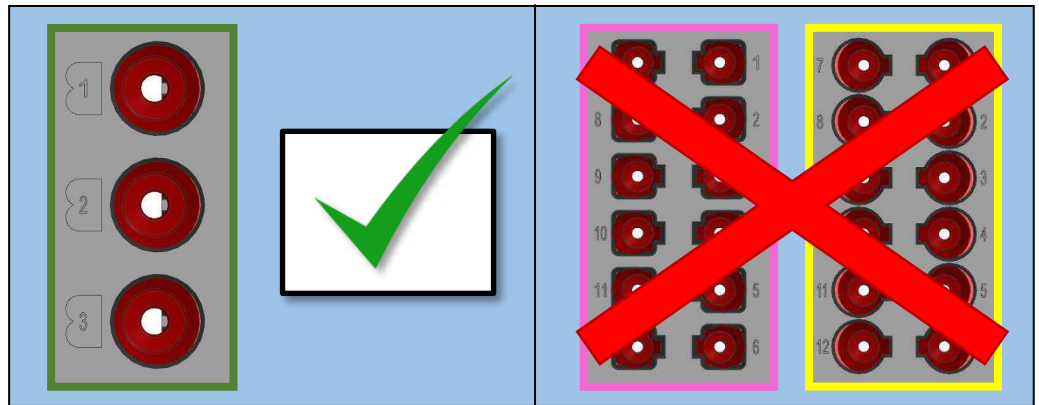

Power
Cable Insulation Diameter
Range 3.0 – 5.0mm

Important:

- Hold cable while putting in male terminals
- Insert terminals 90° to the rear cover
- Insert terminal nose carefully through seal opening

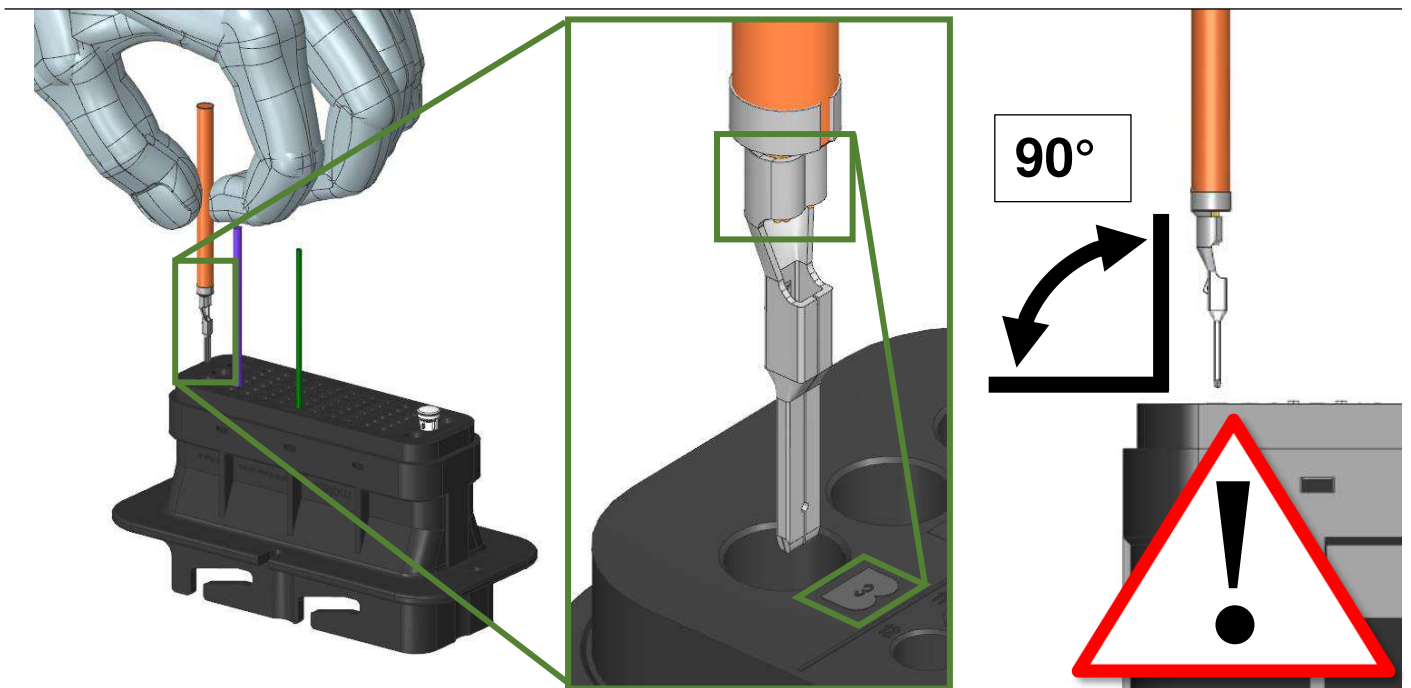

Demonstration example

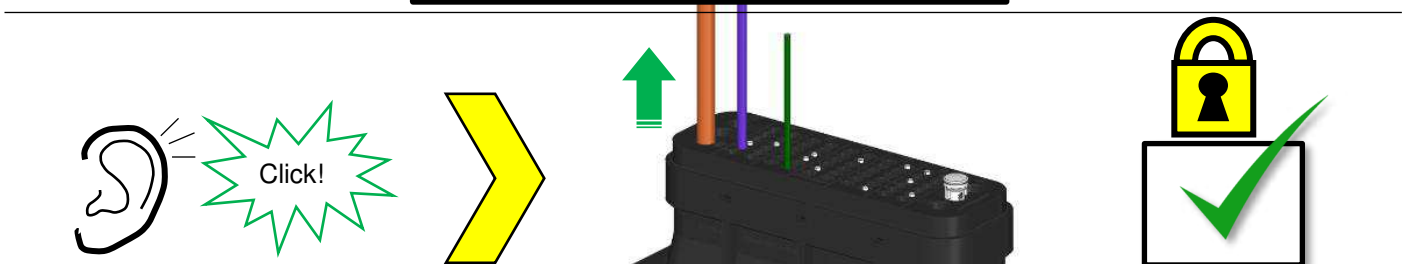

This specification is a controlled document.

Page 28 of 52

STEP 7 – CLOSE TPA



**Populate connector fully
No holes left empty**

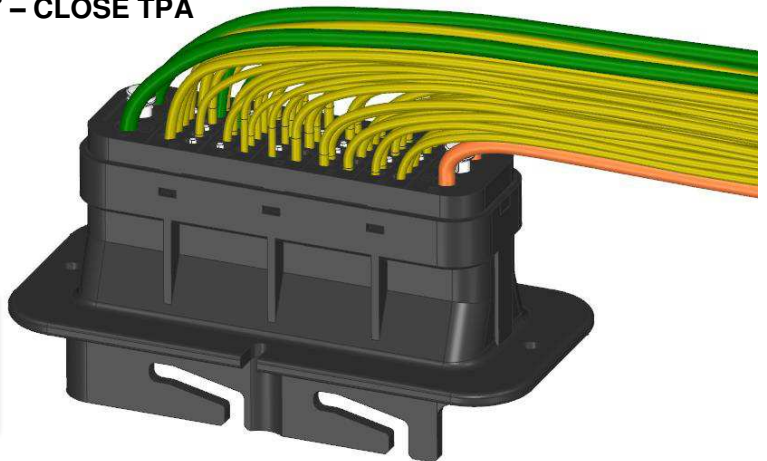

Final Check

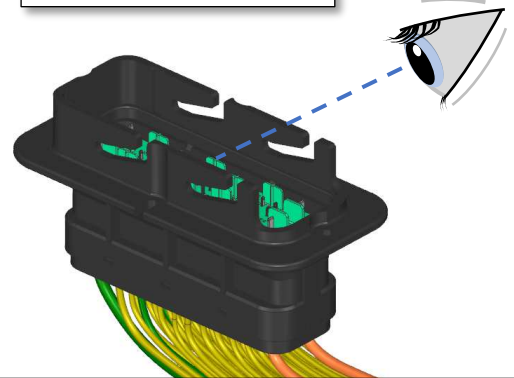
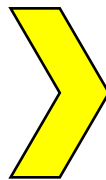
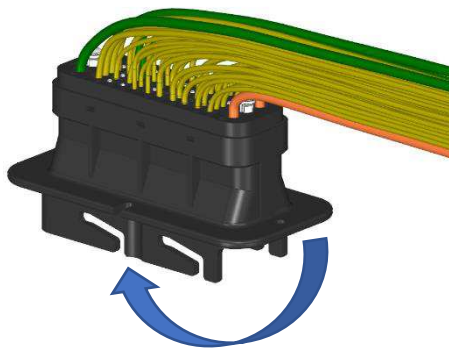

Note: Where terminals are not shown, blind cavity plugs have been used

Demonstration example



Ensure all cables are pushed forward fully

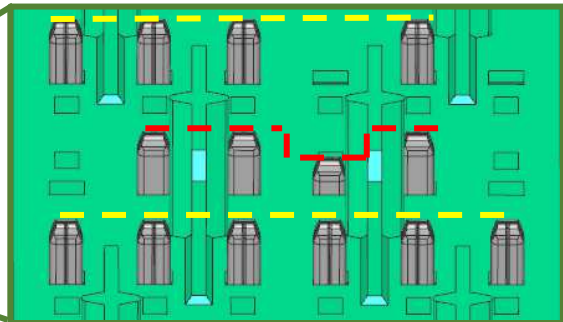
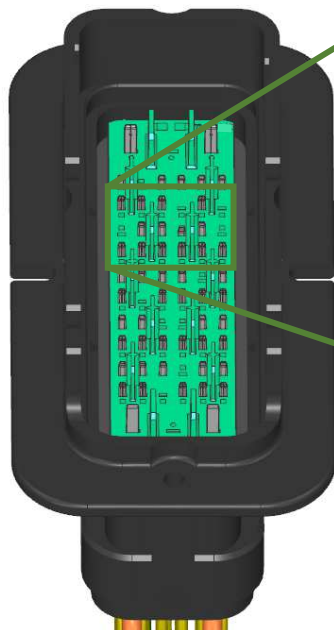

STEP 7 – CLOSE TPA

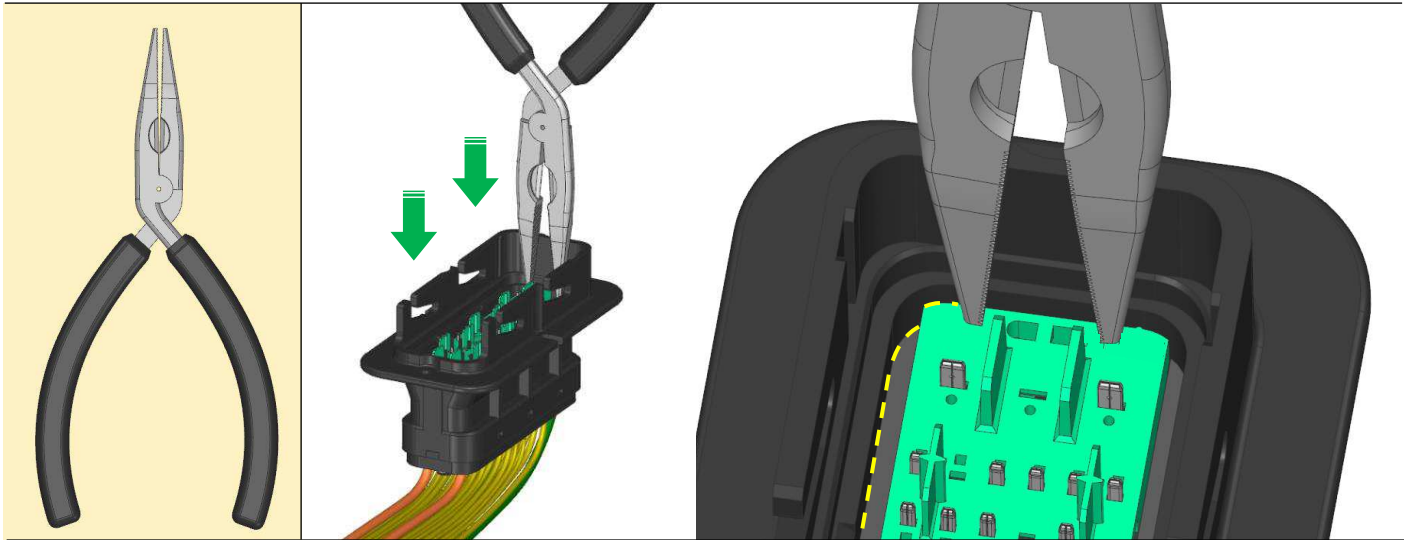

Note: Where terminals are not shown, blind cavity plugs have been used

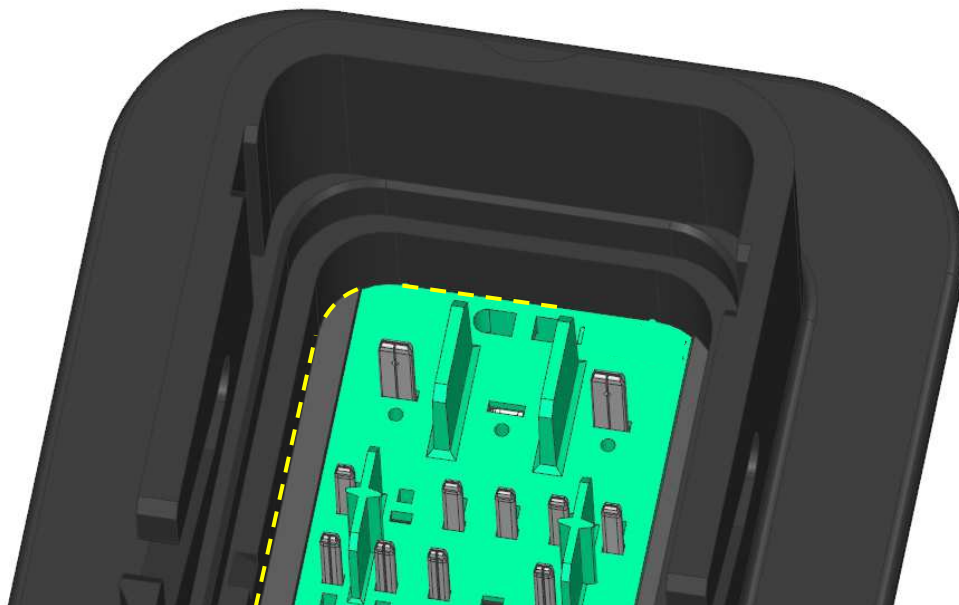

STEP 8 – APPLY WIRE DRESS/CONDUIT INTERFACE



- Various configurations of wire dress available.
 - 1 – 3 open exits
 - 4 different exit sizes
- See sales drawing: 2500035
- Appropriate conduit must be used with wire dress
- Example shown for demonstration only
- Direction of exit(s) per wiring diagram

Tool & parts needed

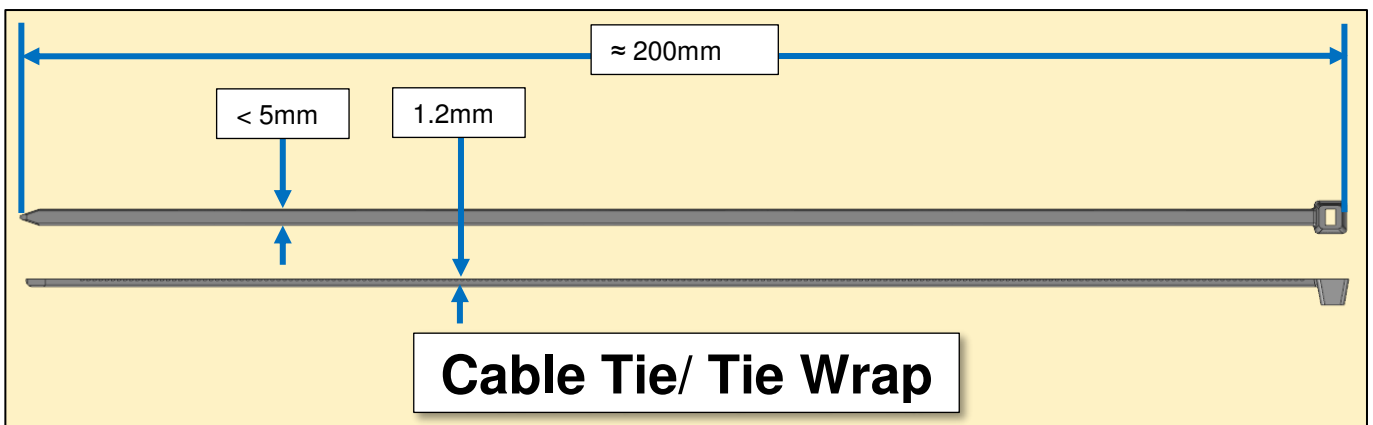
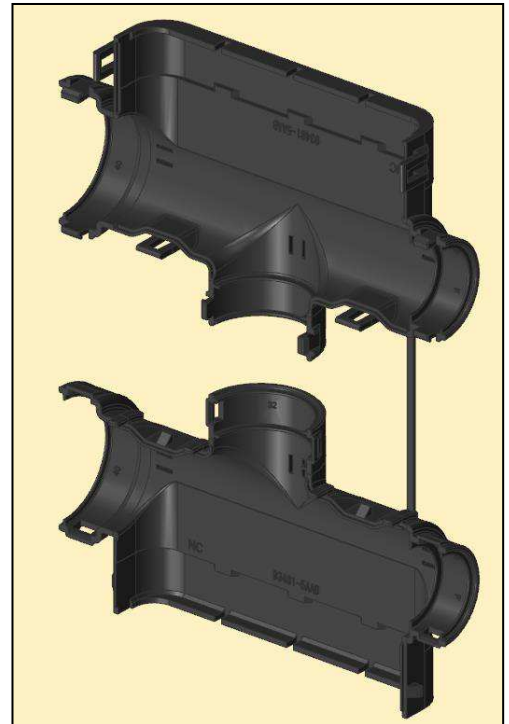
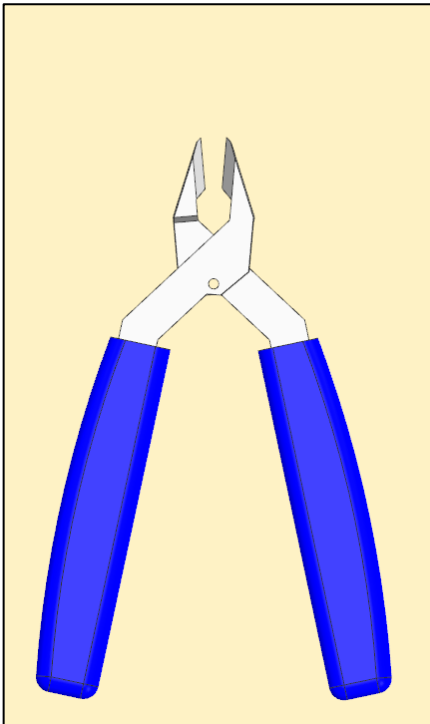

RECOMMENDED ASSEMBLY SEQUENCE

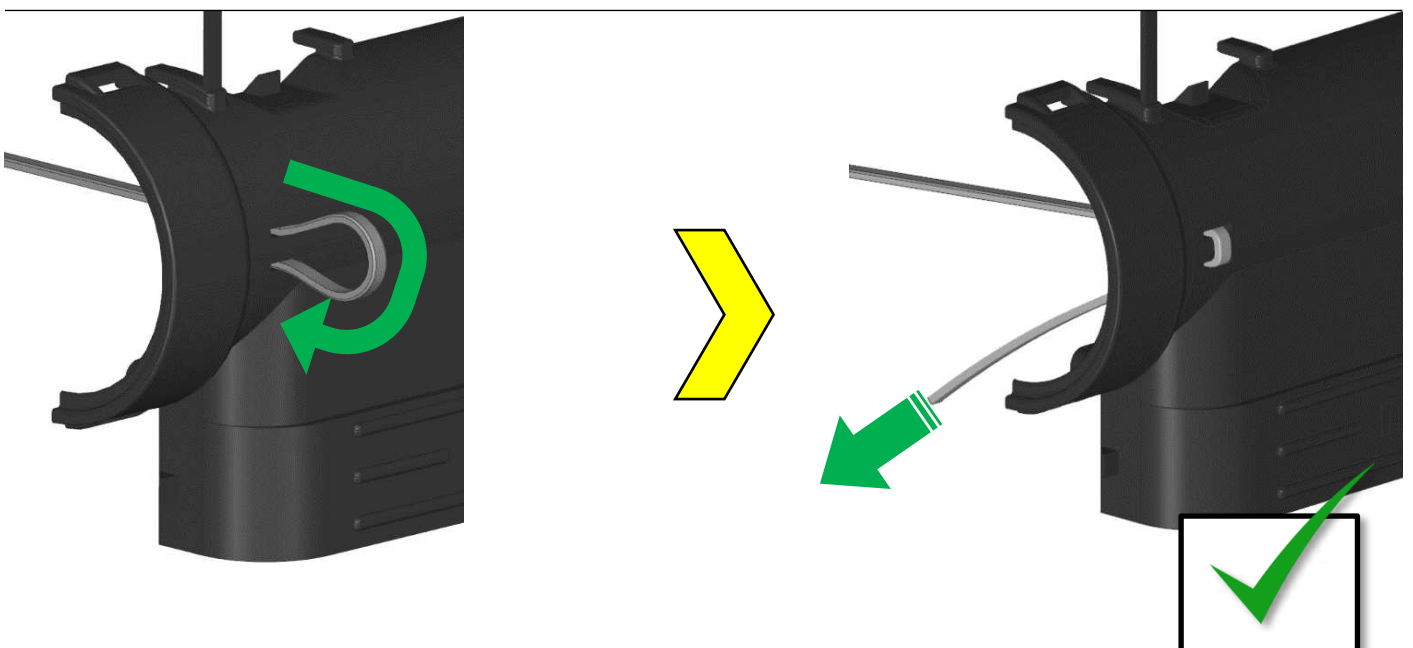
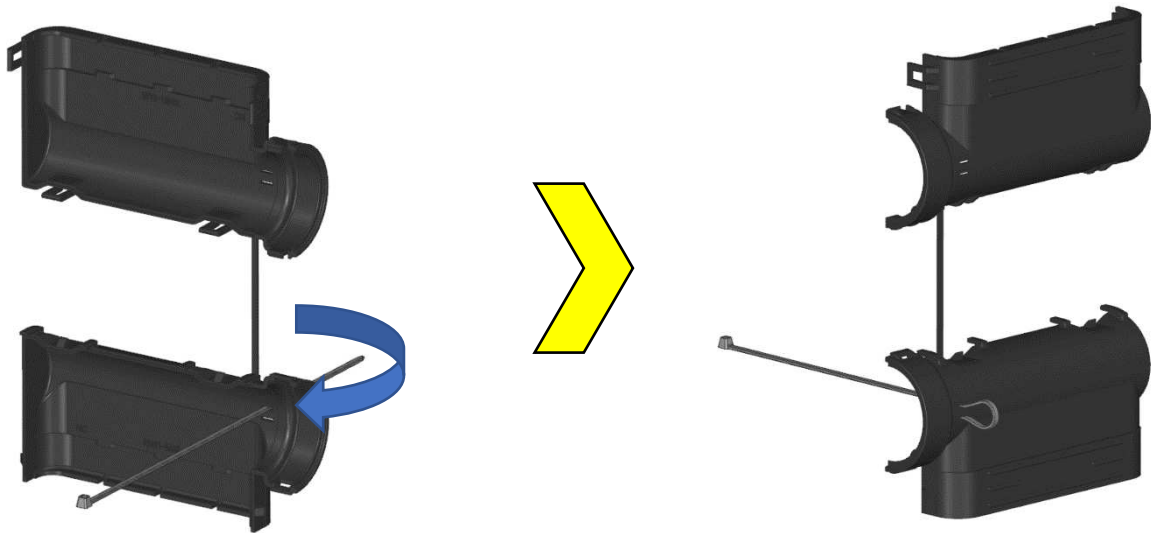
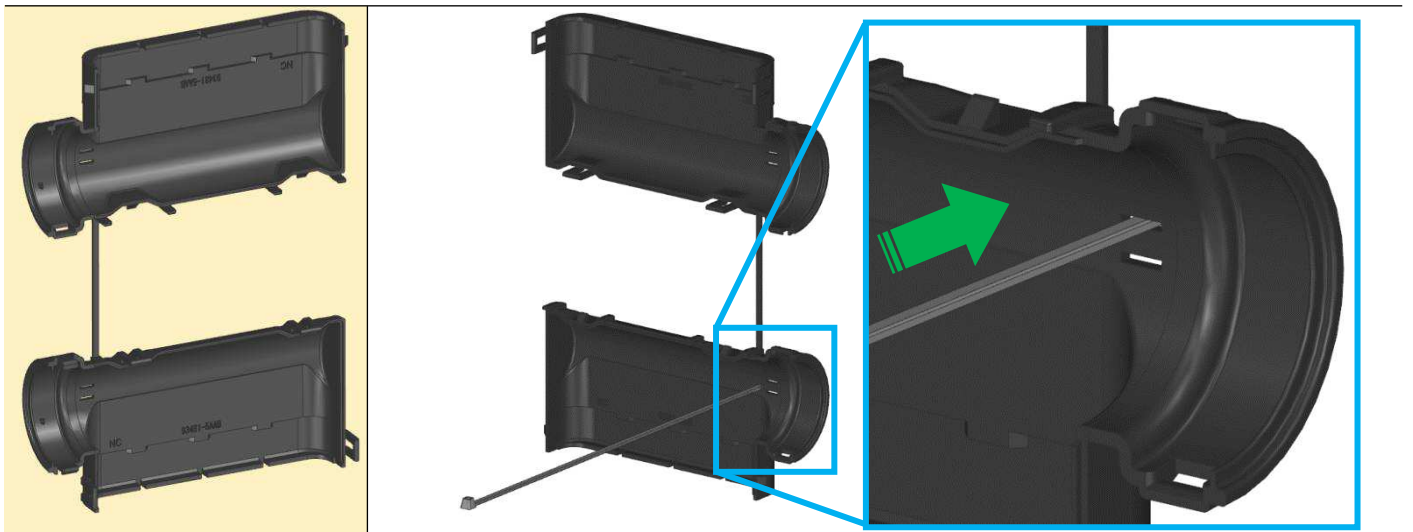

RECOMMENDED ASSEMBLY SEQUENCE

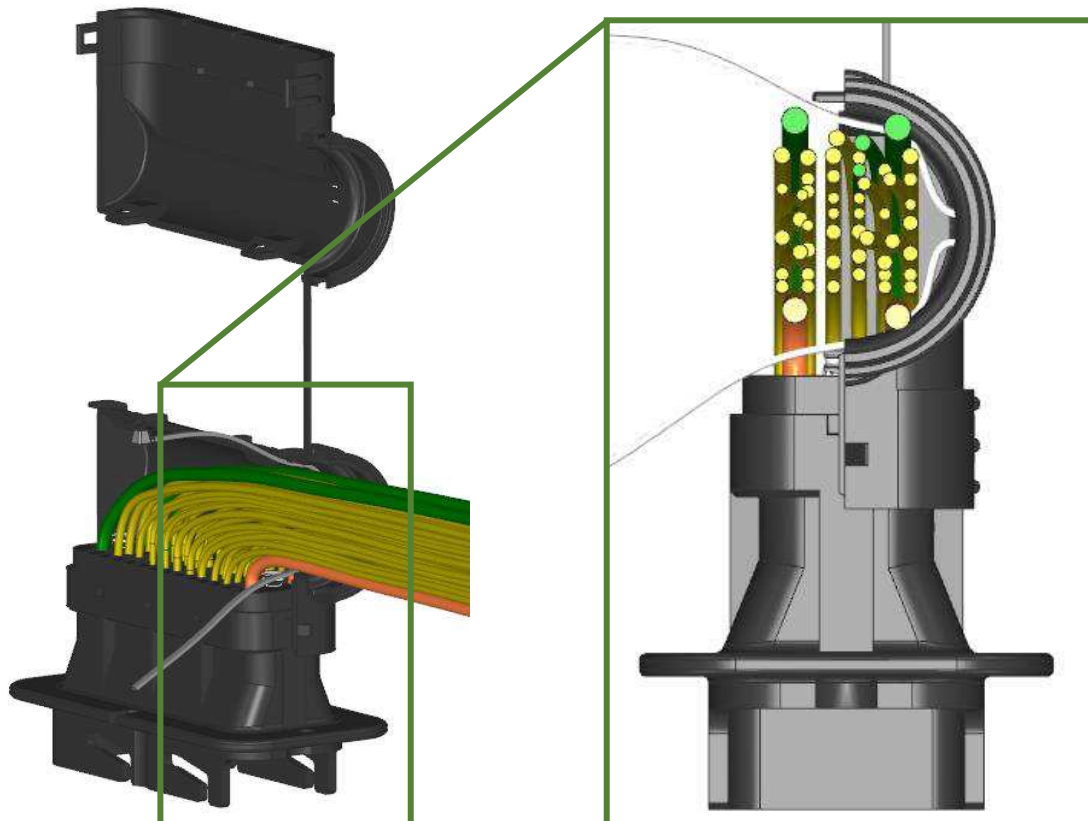
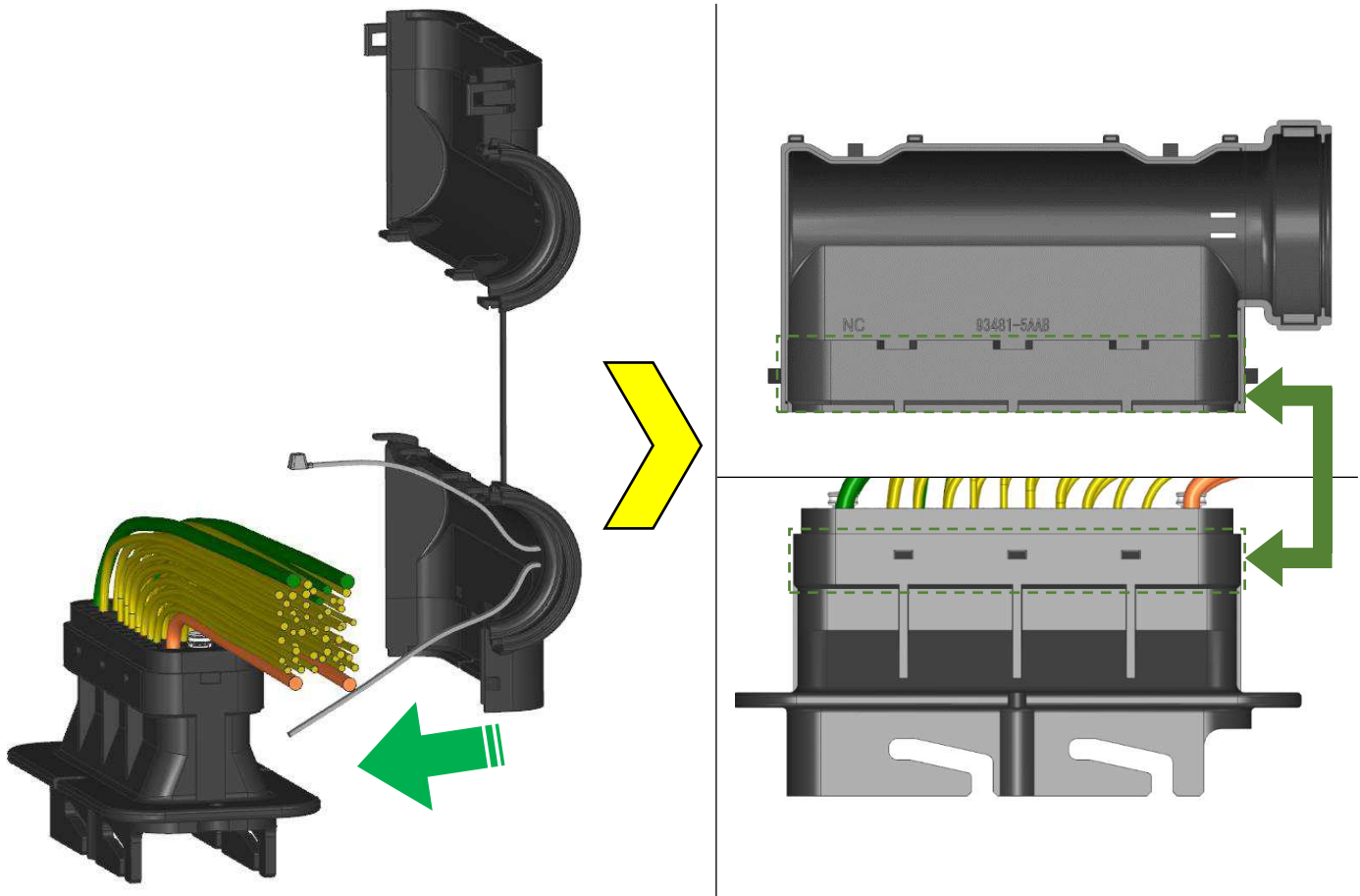

RECOMMENDED ASSEMBLY SEQUENCE

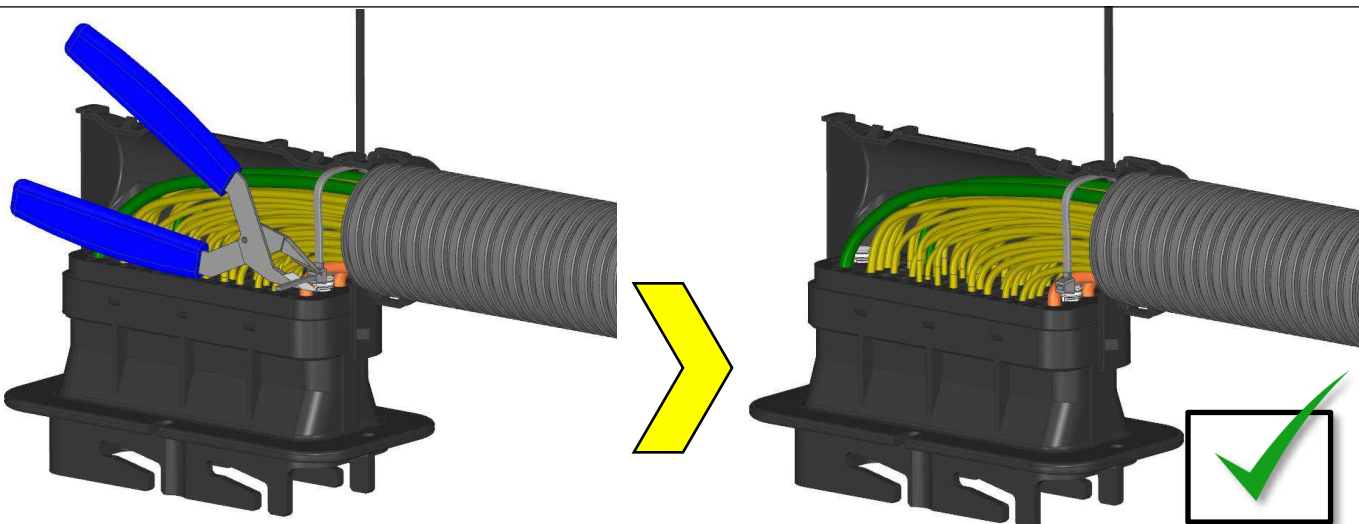
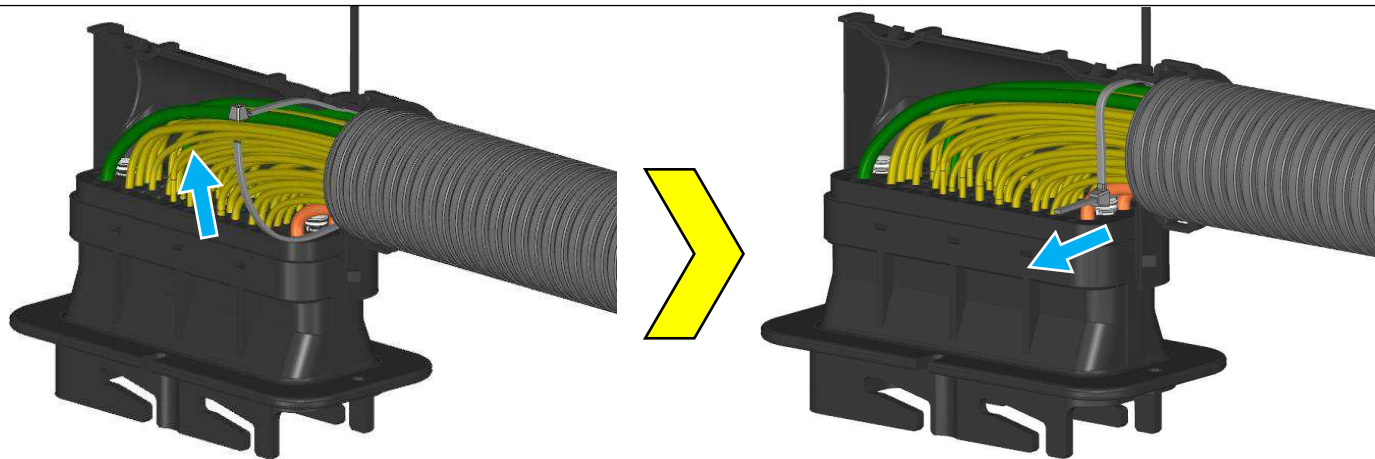
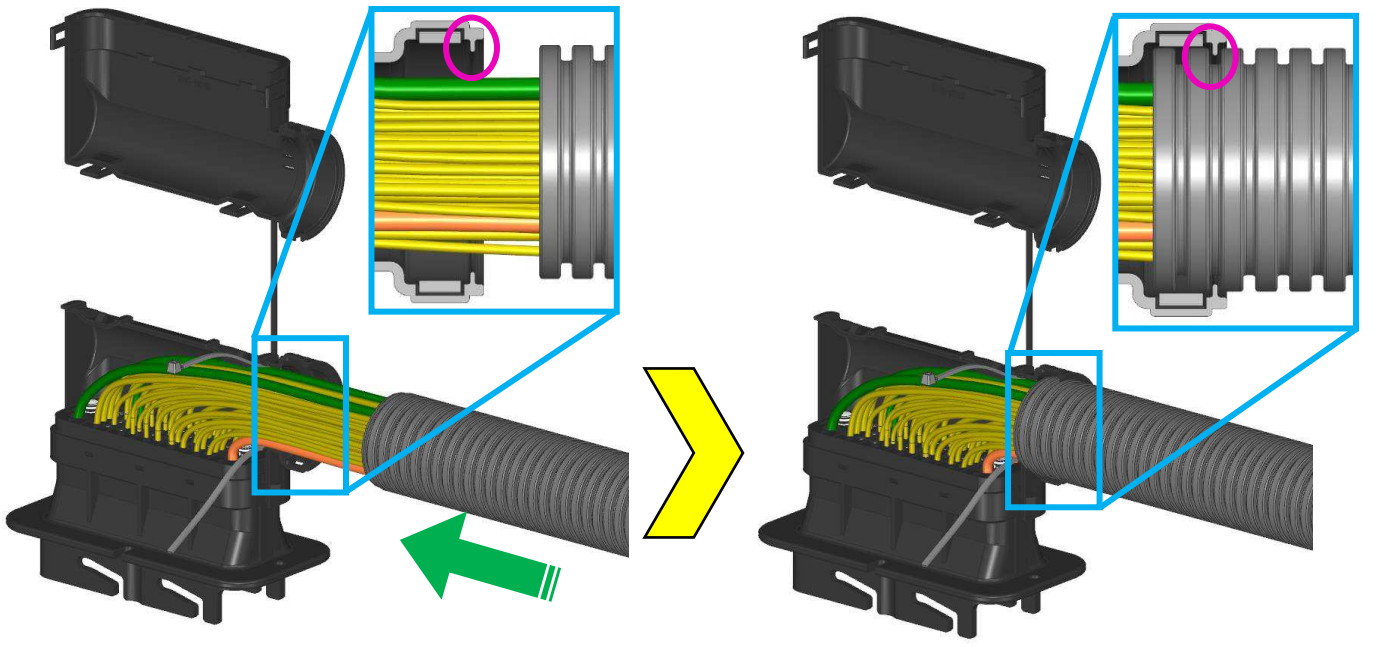

RECOMMENDED ASSEMBLY SEQUENCE

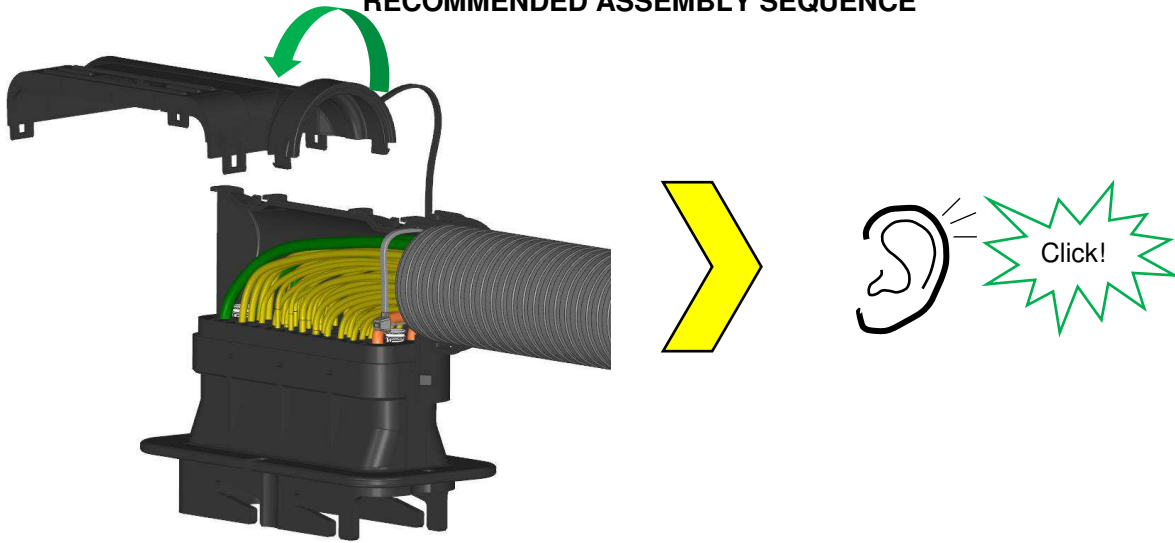

OR

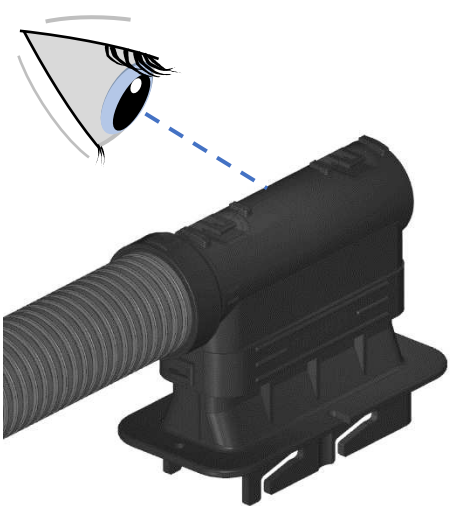
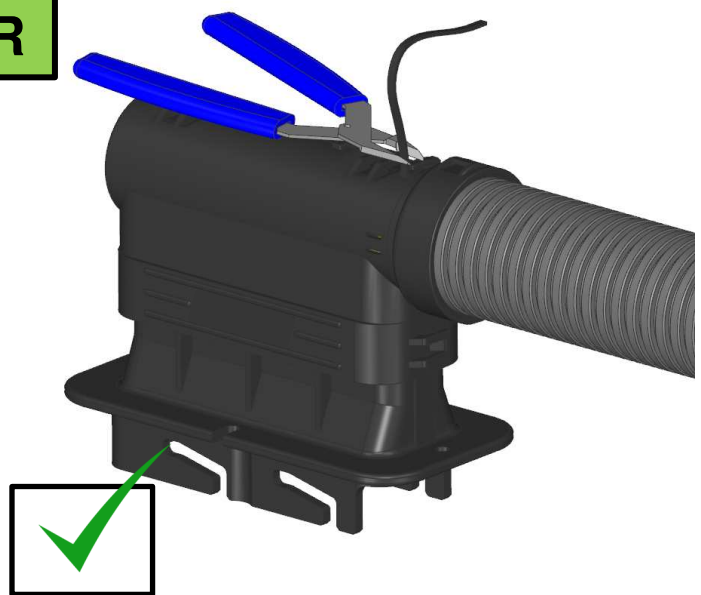
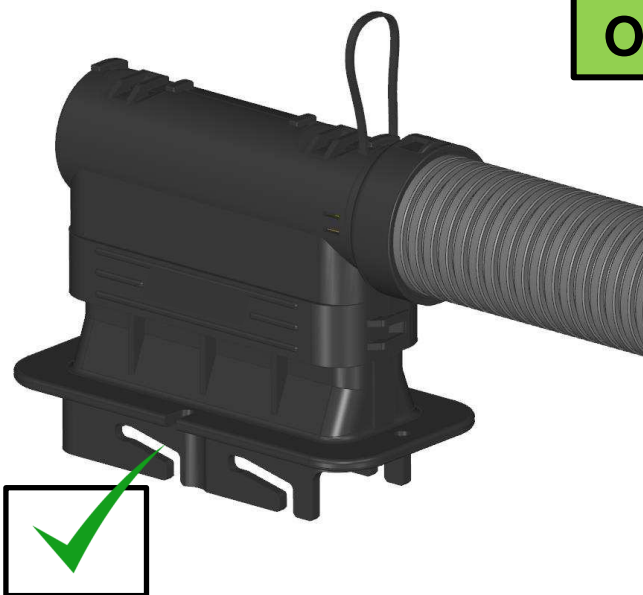

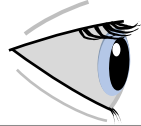

RECOMMENDED CHECKS

Female TPA is closed

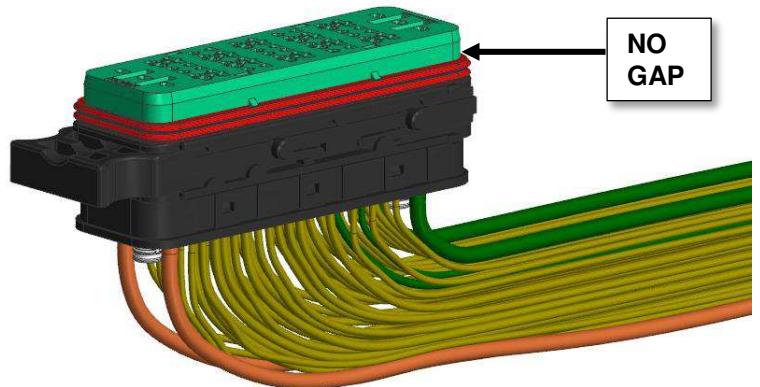

Male TPA is closed

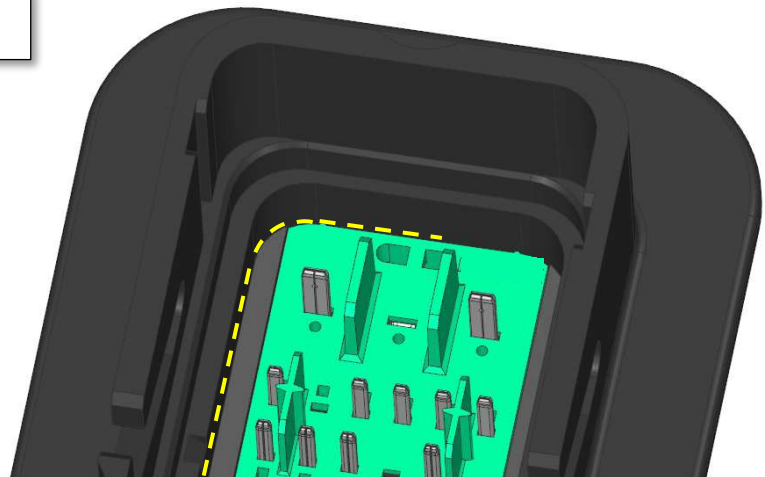

Check for front seal roll

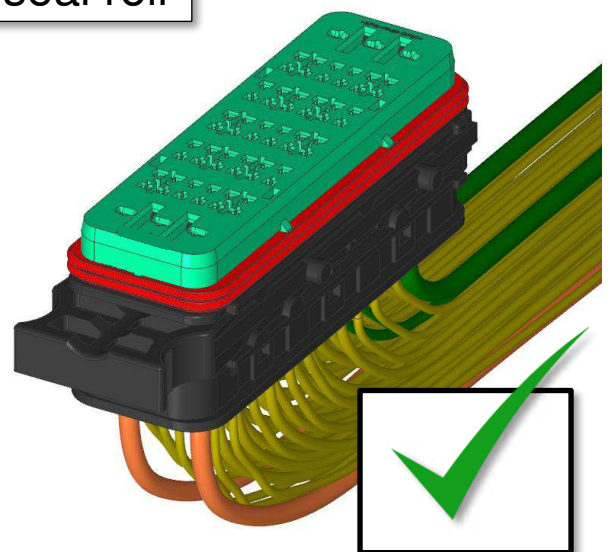
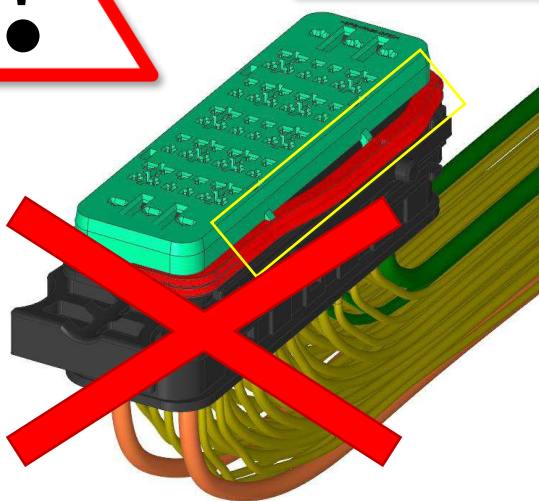

MATING THE CONNECTORS

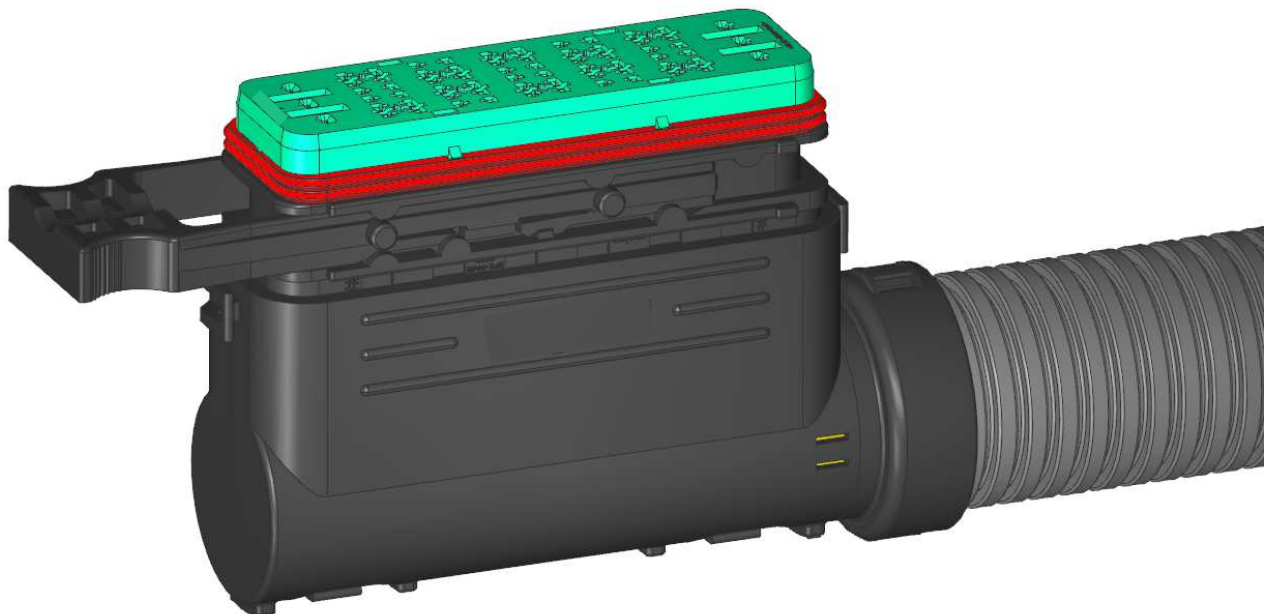

MATING THE CONNECTORS

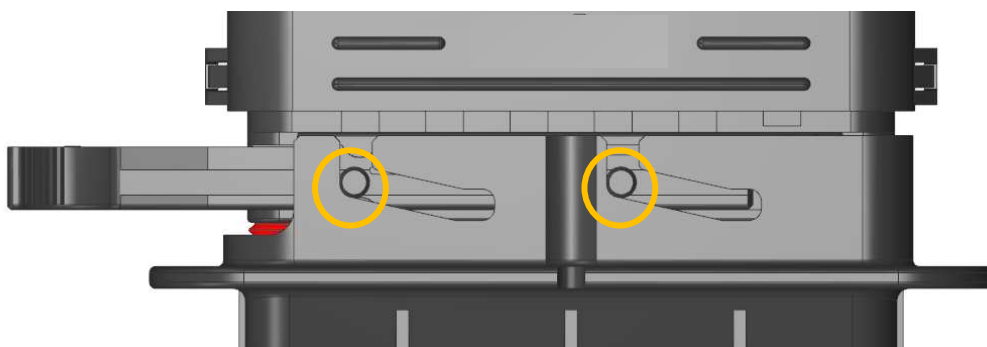
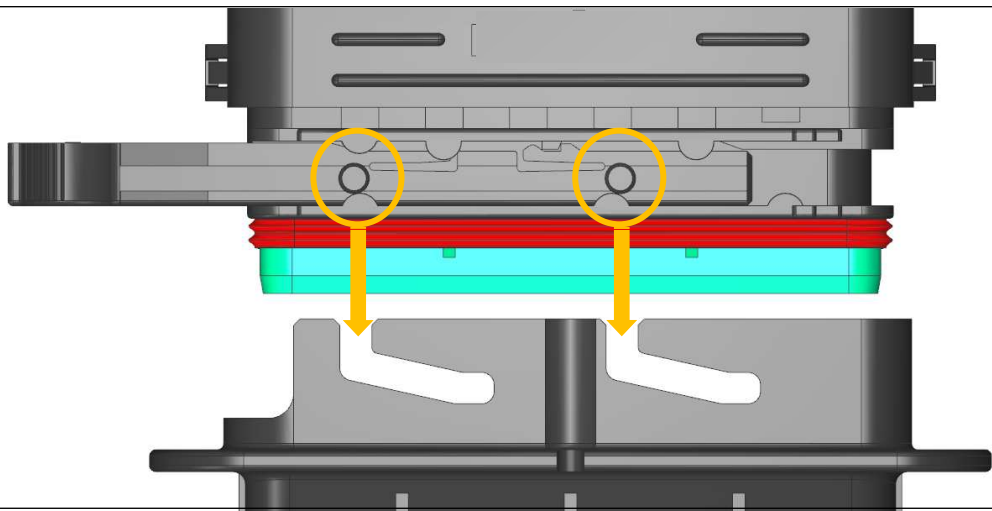
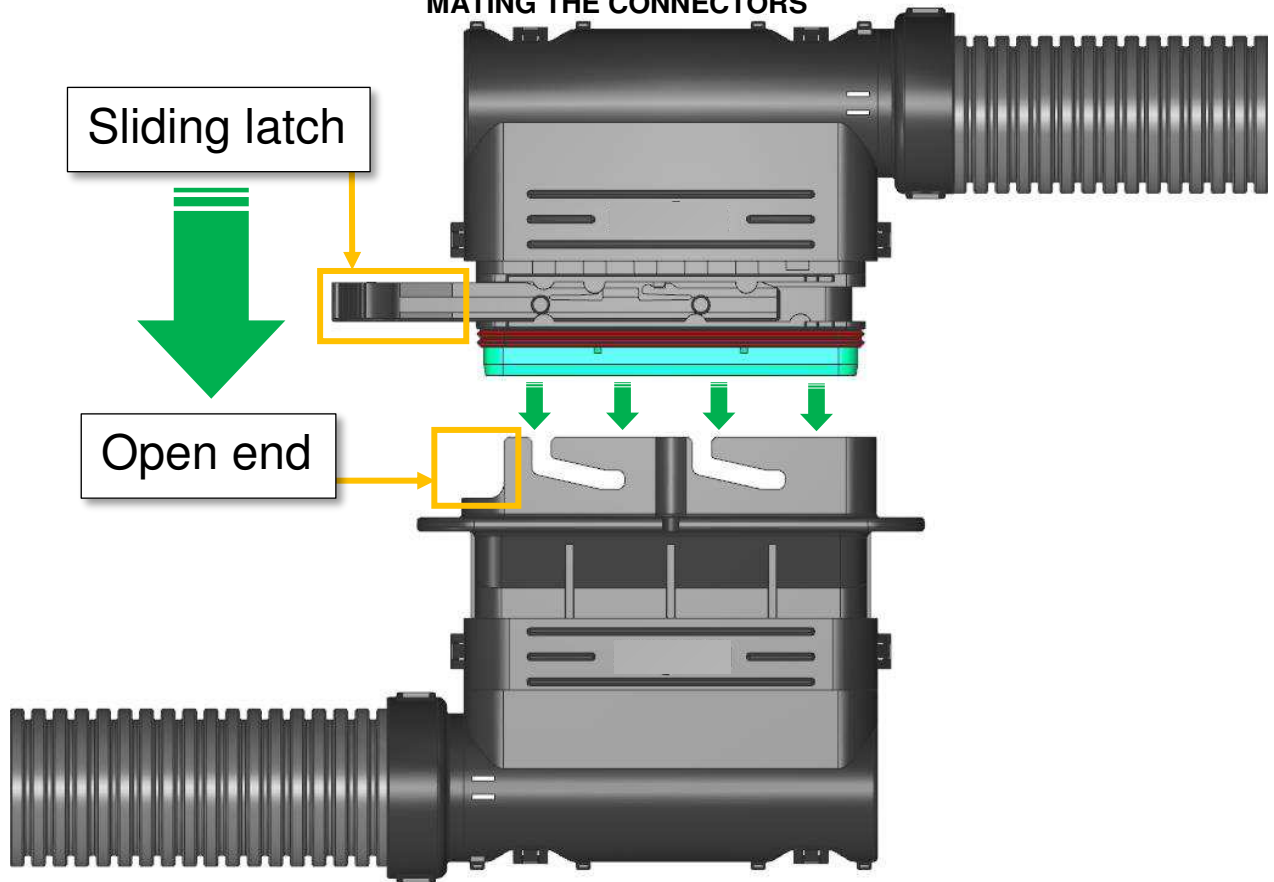

MATING THE CONNECTORS

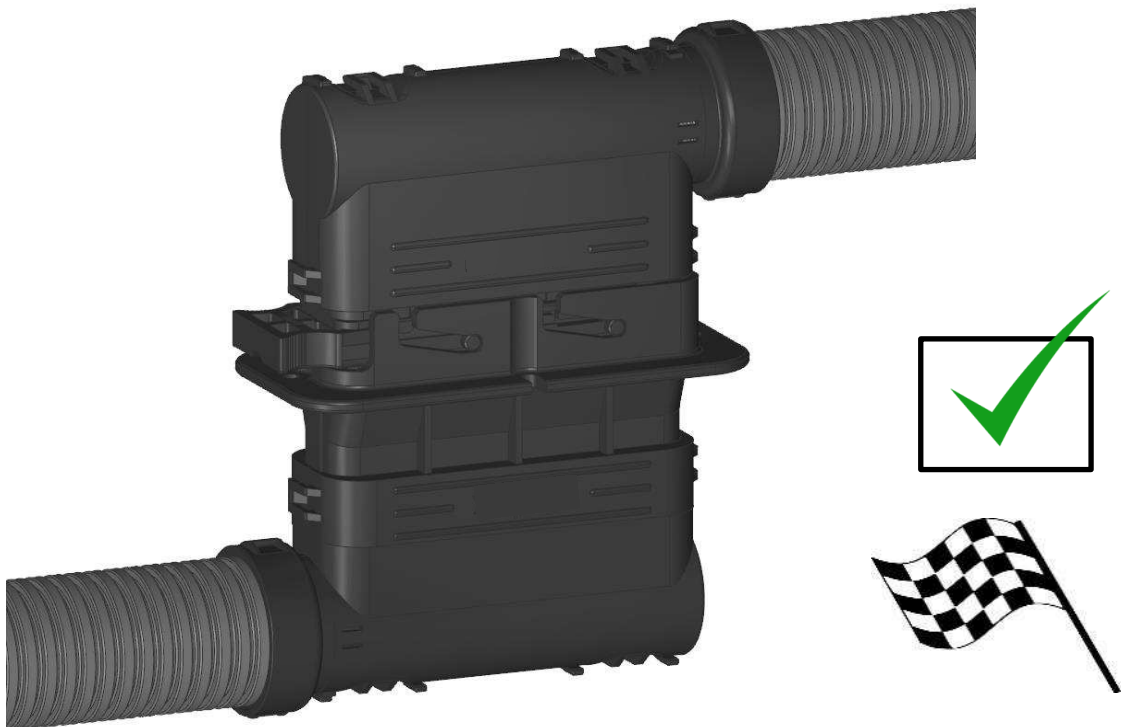
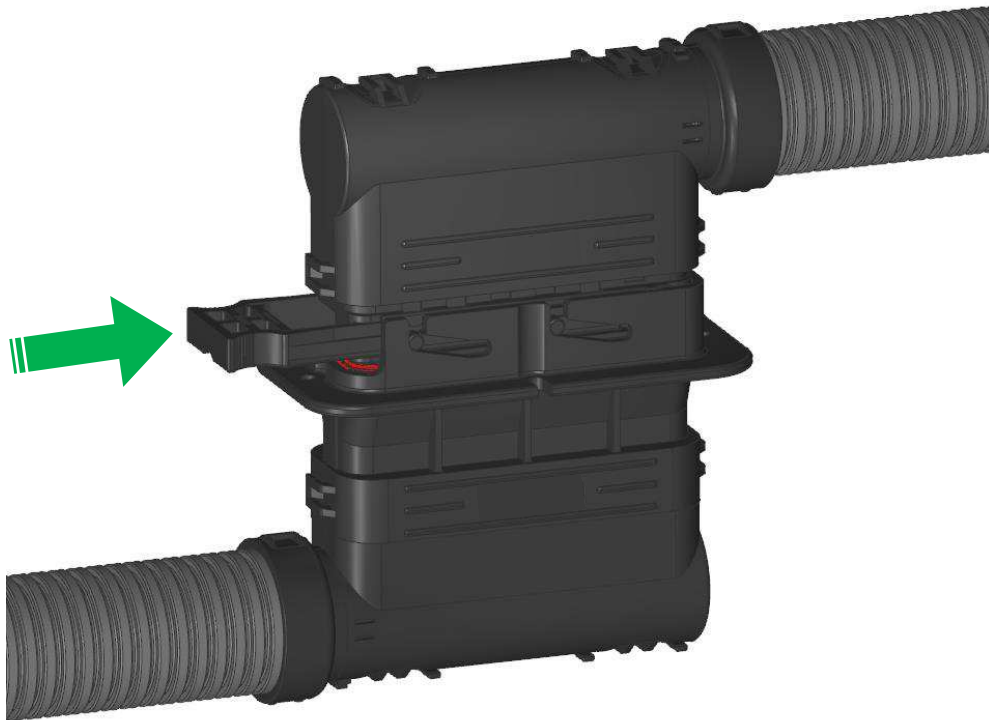

UNMATING THE CONNECTORS

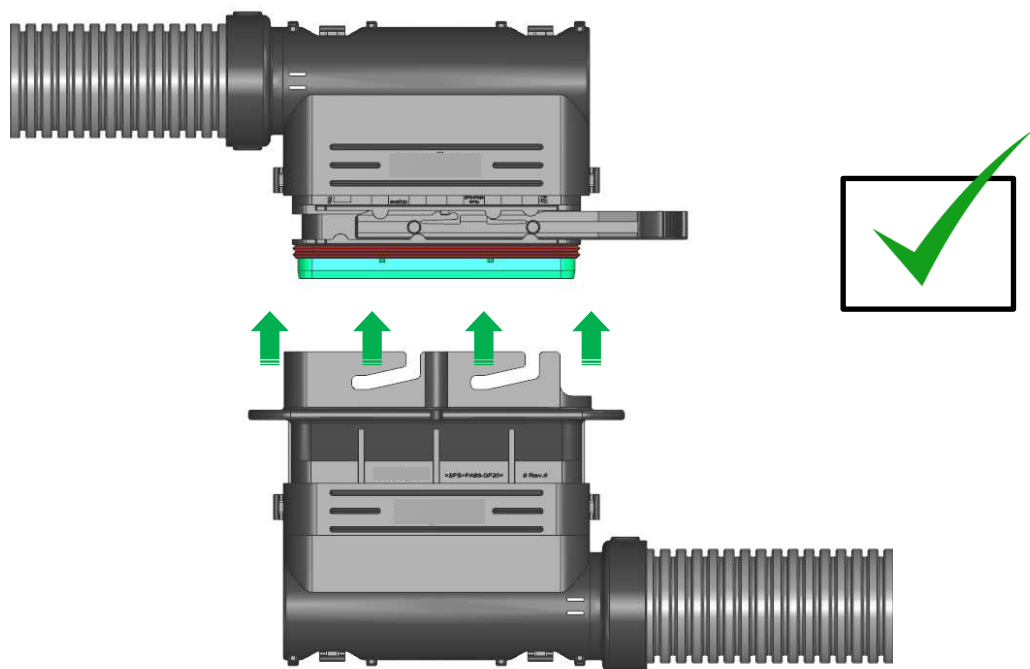
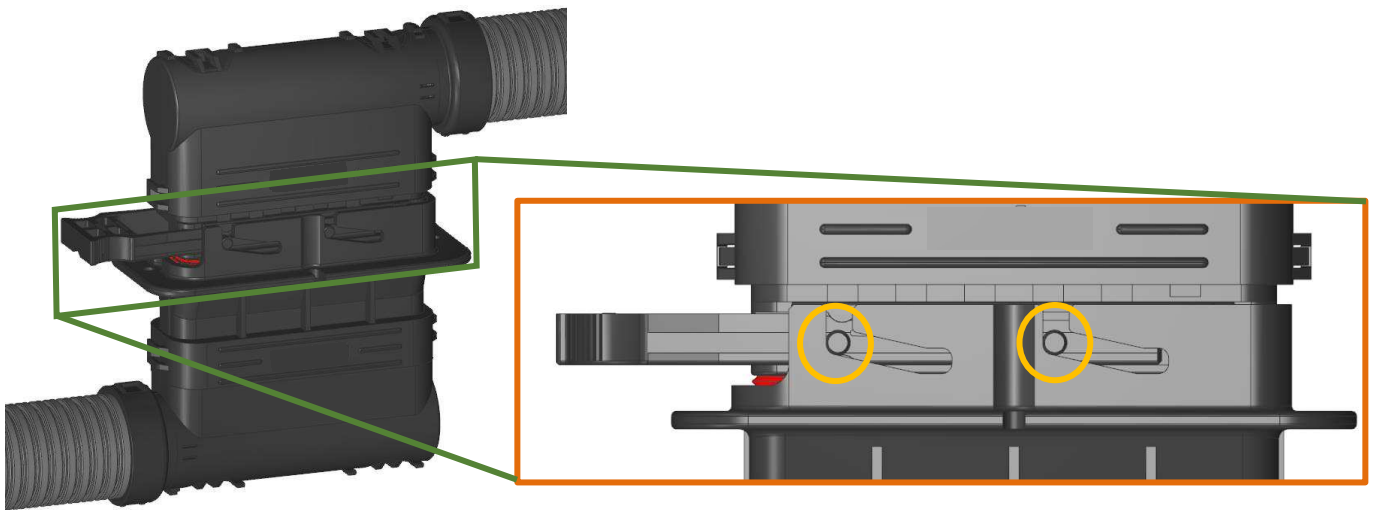
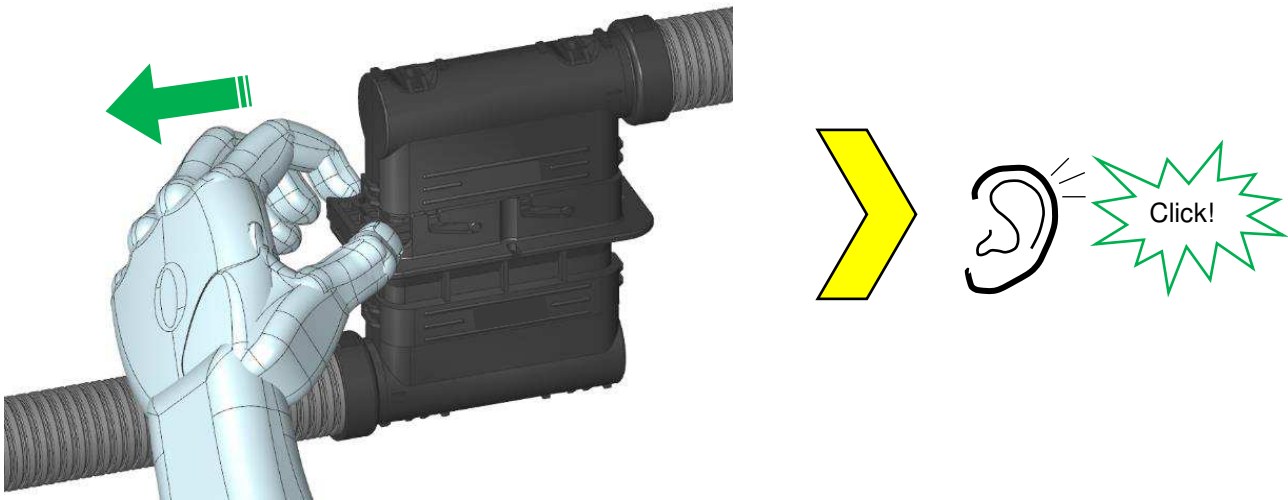

SUGGESTED REMOVAL SEQUENCE

Removal sequence same for both male and female connectors

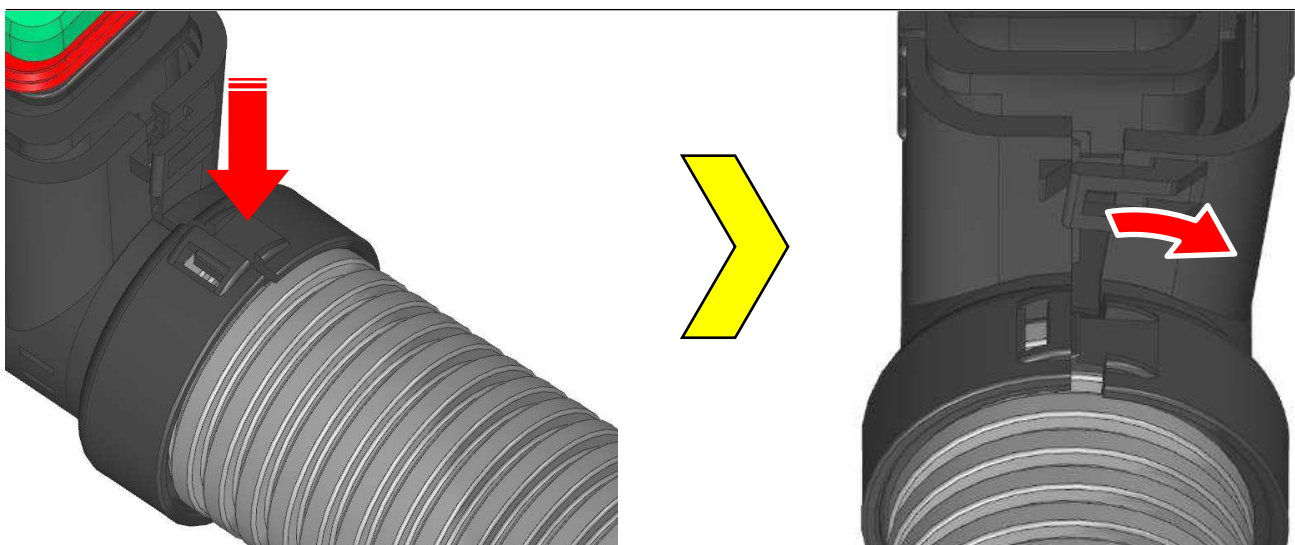
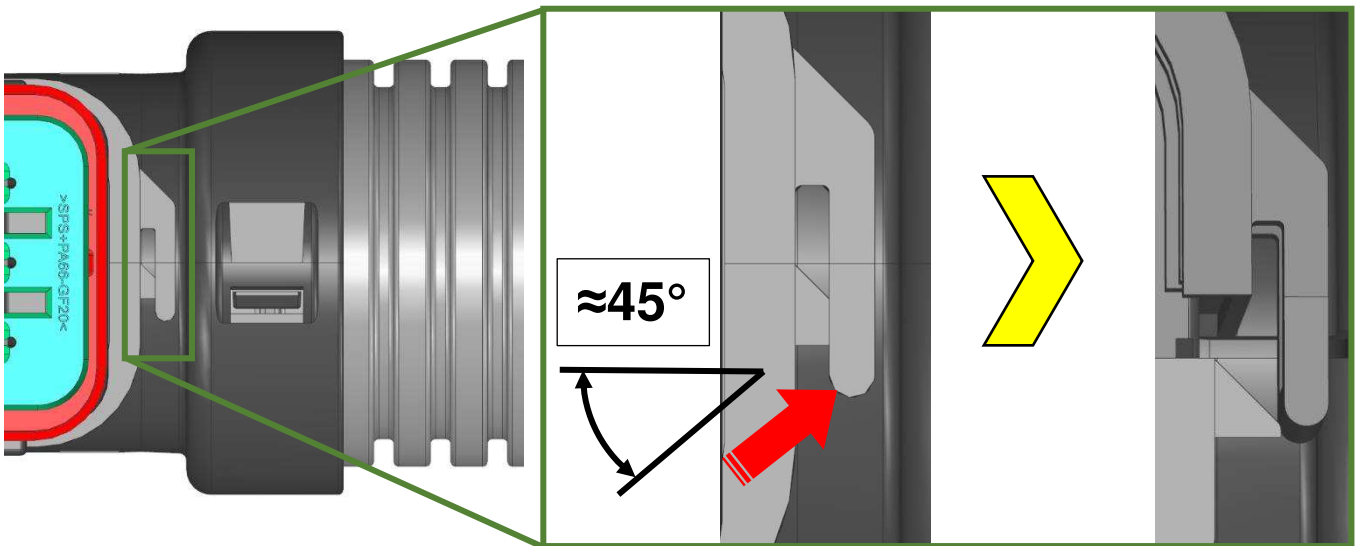
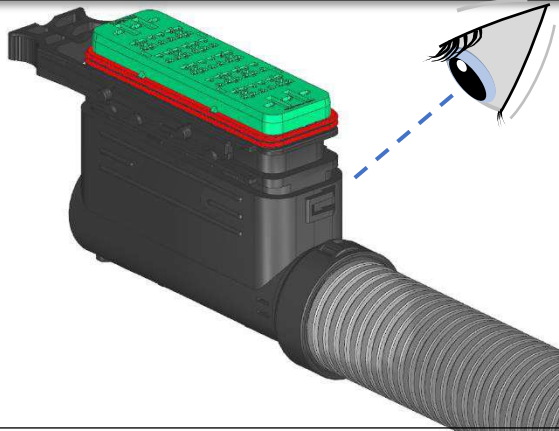

SUGGESTED REMOVAL SEQUENCE

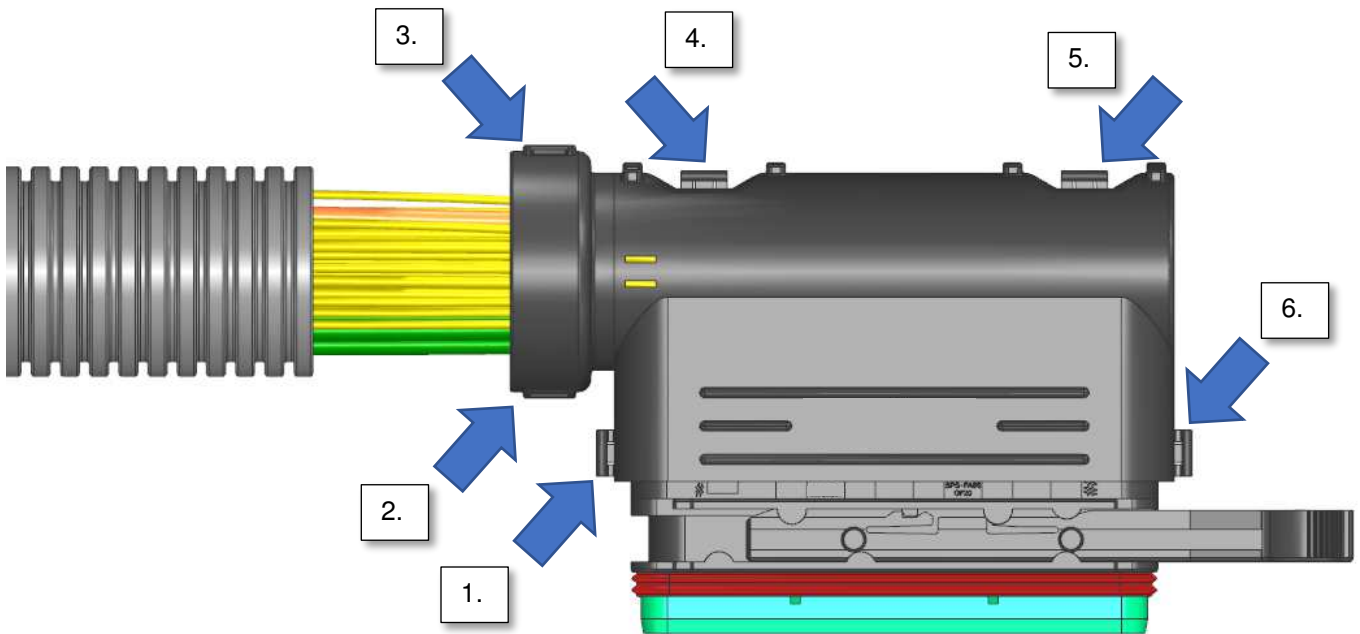
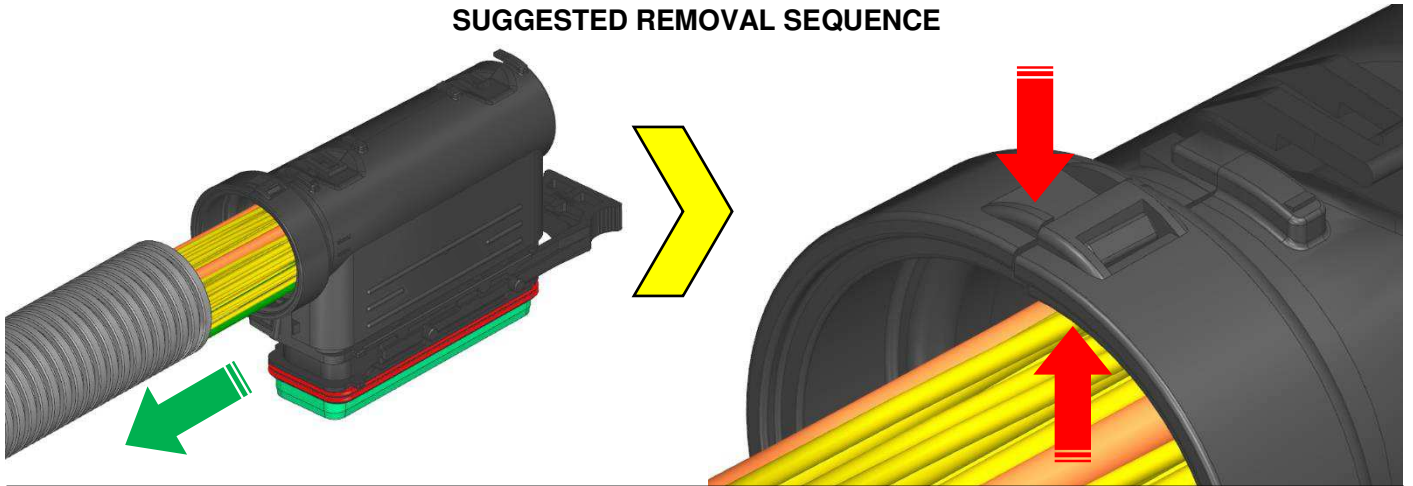

- Recommend sequence above
- Always start at latch nearest the connector
- Easier to start at an open exit side
- Continue de-latching in Clockwise / Anti-clockwise direction
- Same method for each latch & exit

REMOVING SIGNAL BLIND CAVITY PLUGS FROM FEMALE ASSEMBLY

Open TPA – see sheet 6



Do not damage cables when removing blind cavity plug

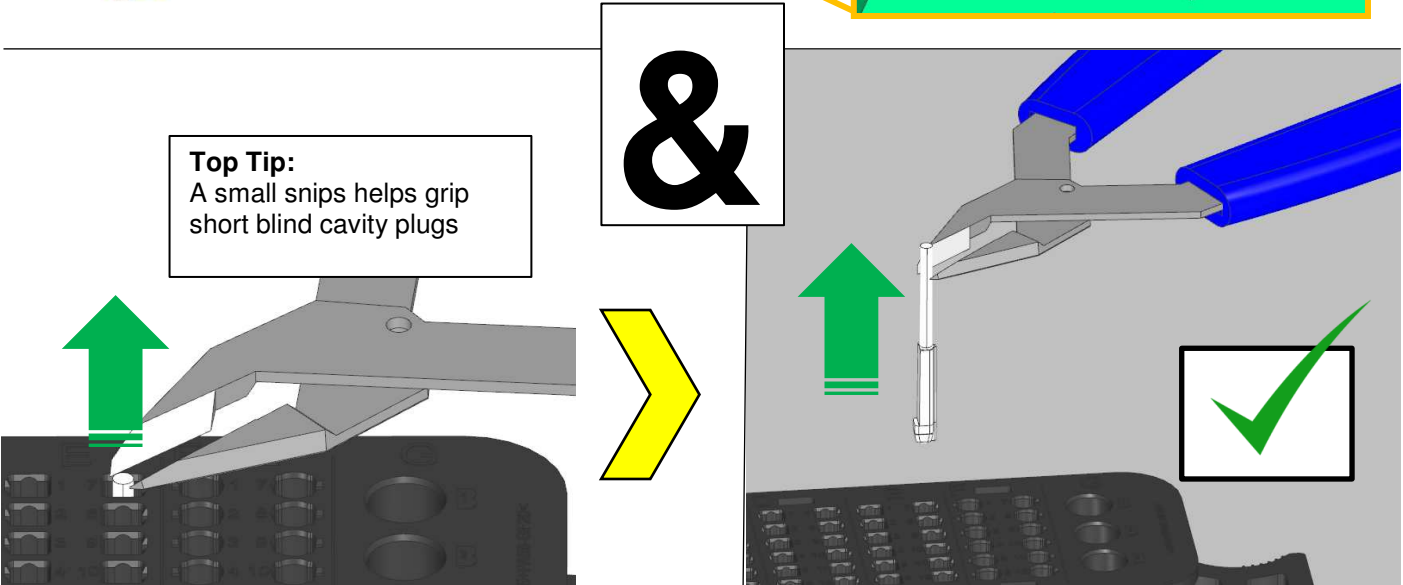
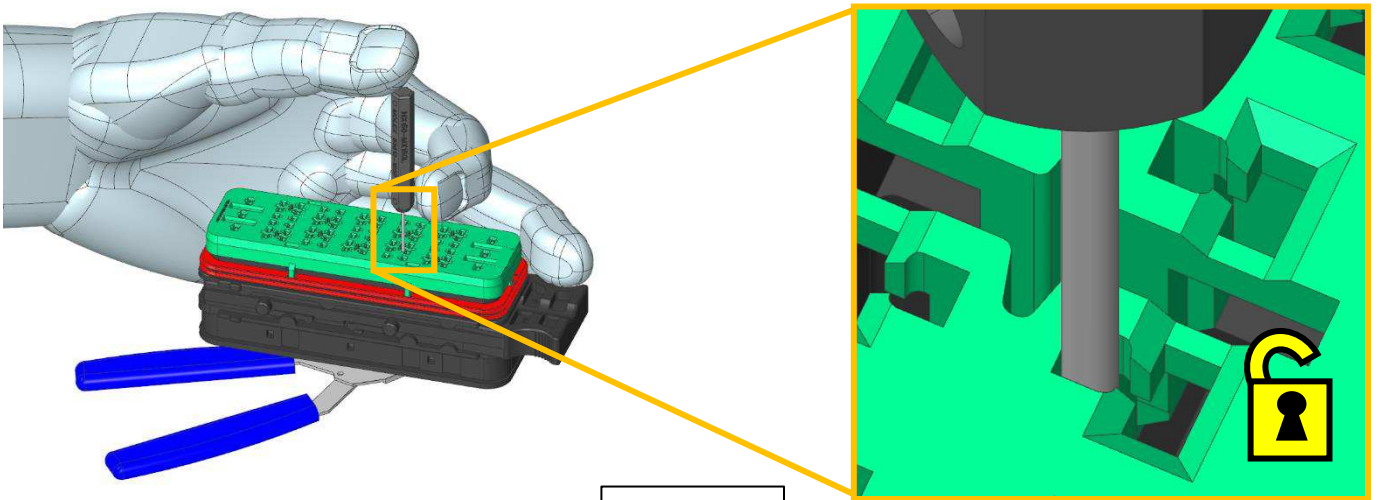
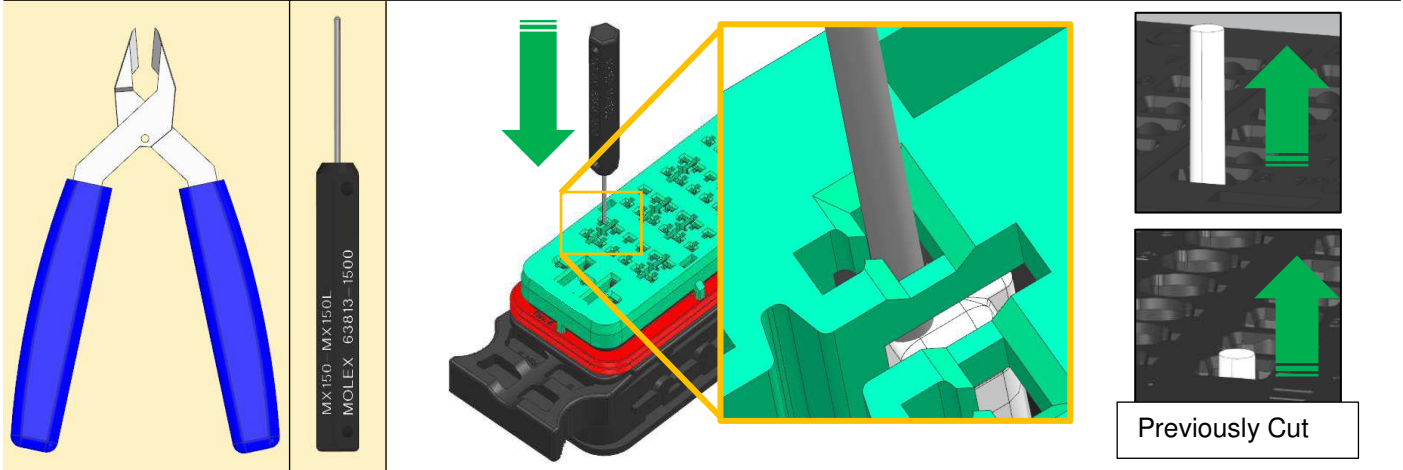

REMOVING POWER BLIND CAVITY PLUGS FROM FEMALE ASSEMBLY

OPEN TPA – SEE SHEET 6

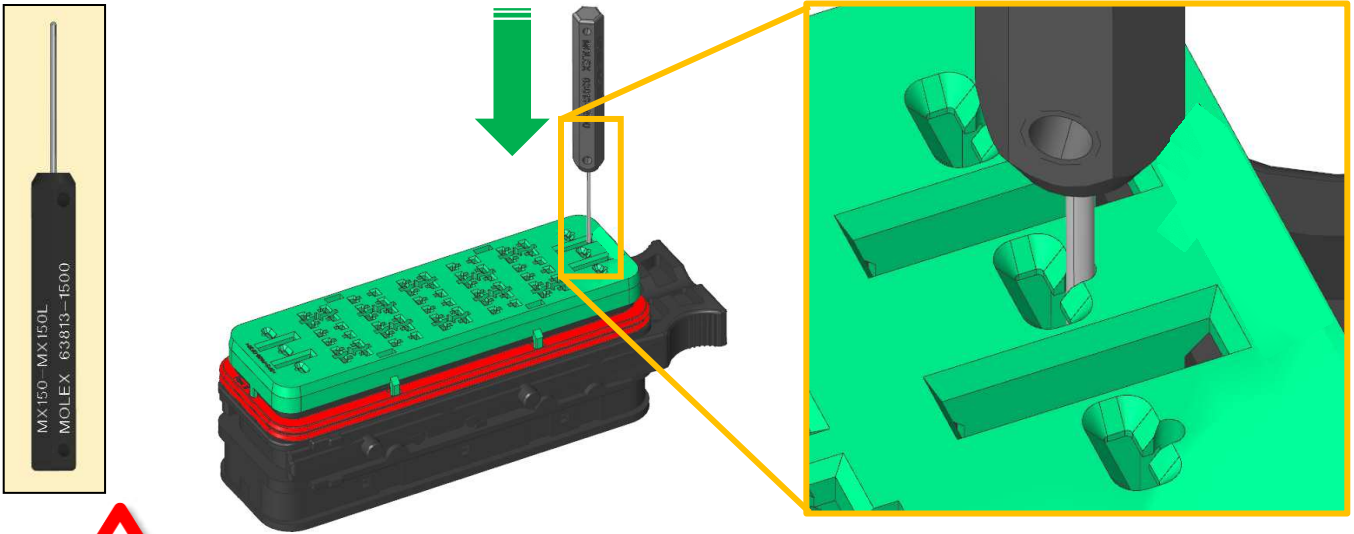

Special case for female power cavities

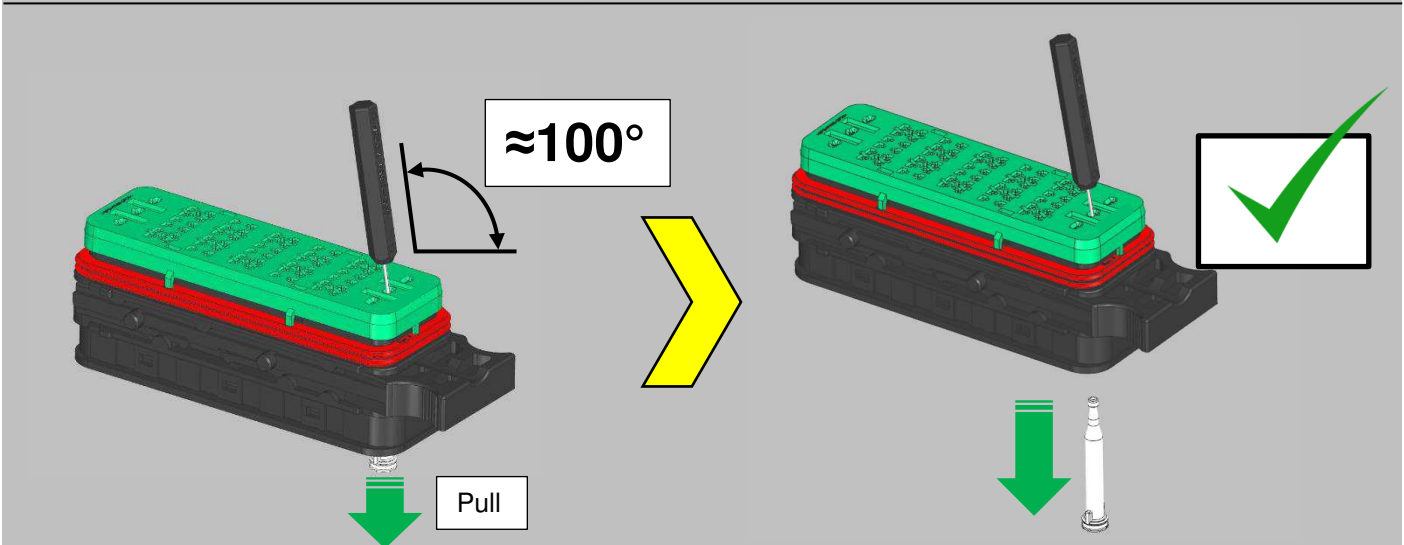
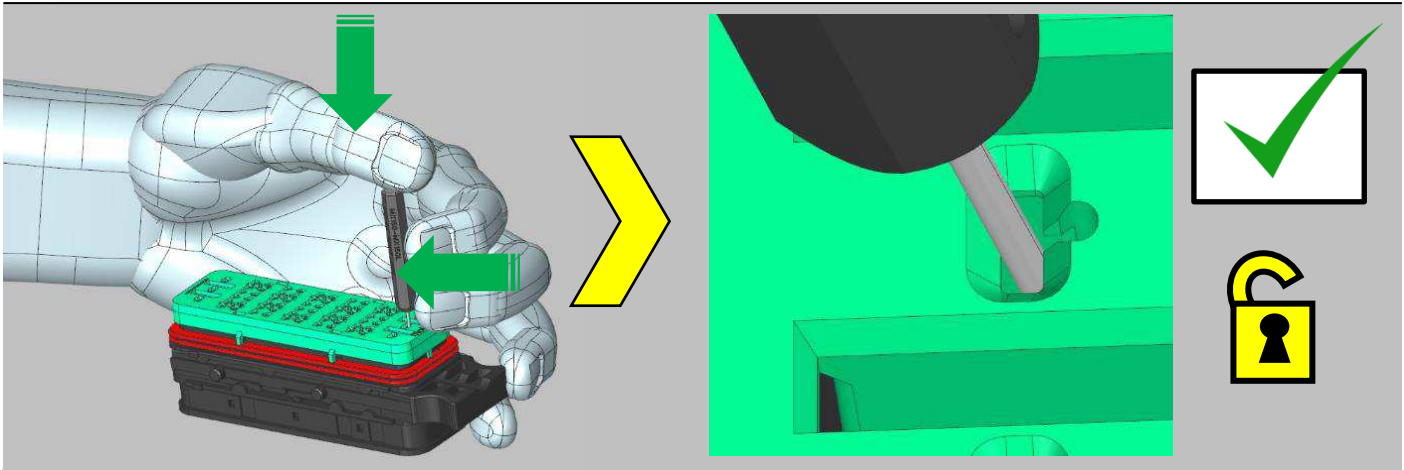

REMOVING SIGNAL & 2.5MM² TERMINALS FROM FEMALE ASSEMBLY

OPEN TPA – SEE SHEET 6

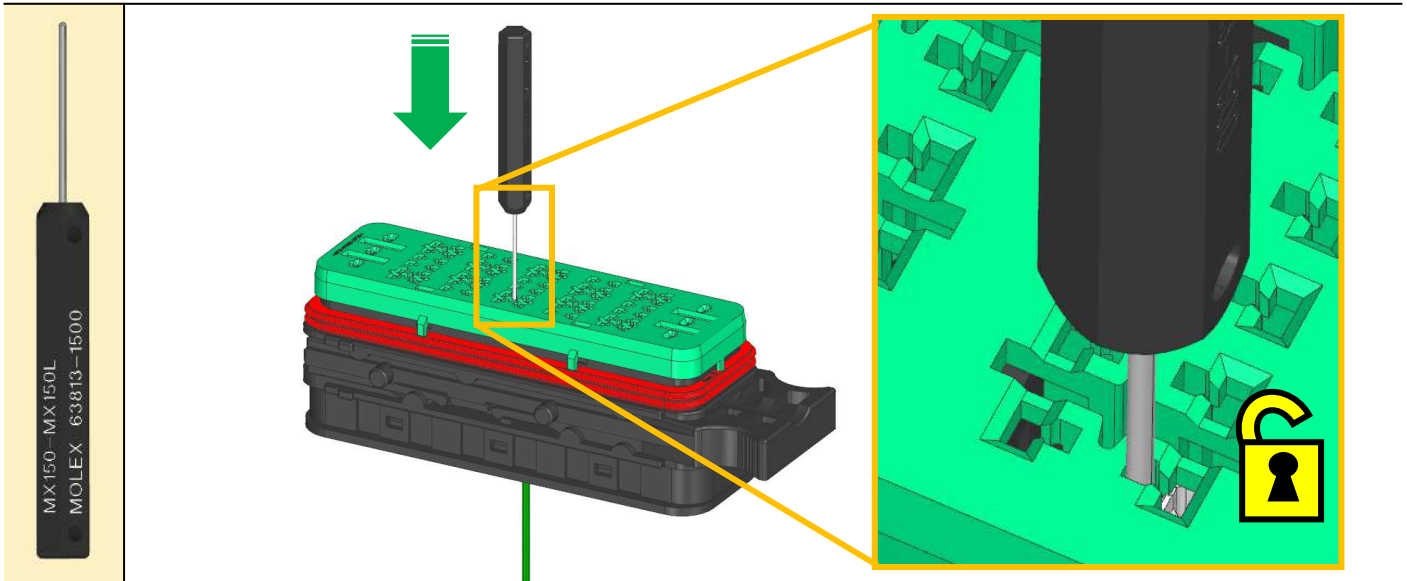

Pull cables carefully through the seal

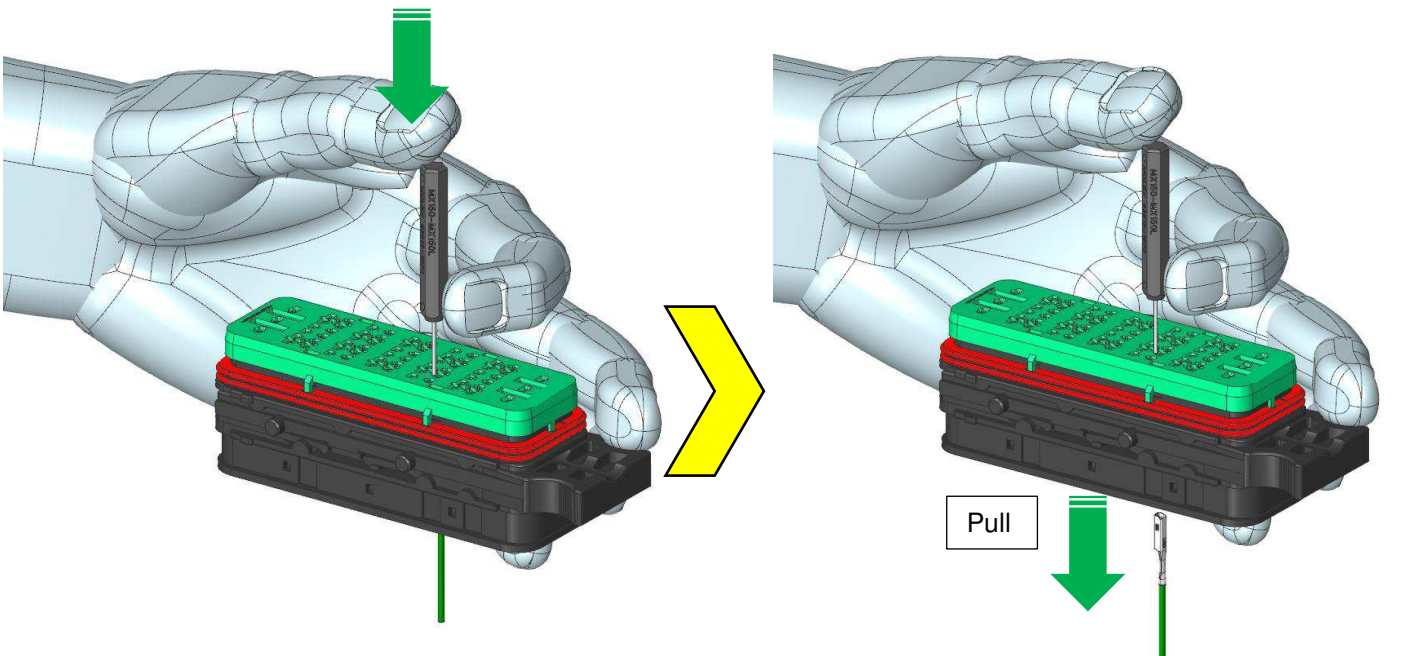

OPEN TPA – SEE SHEET 6

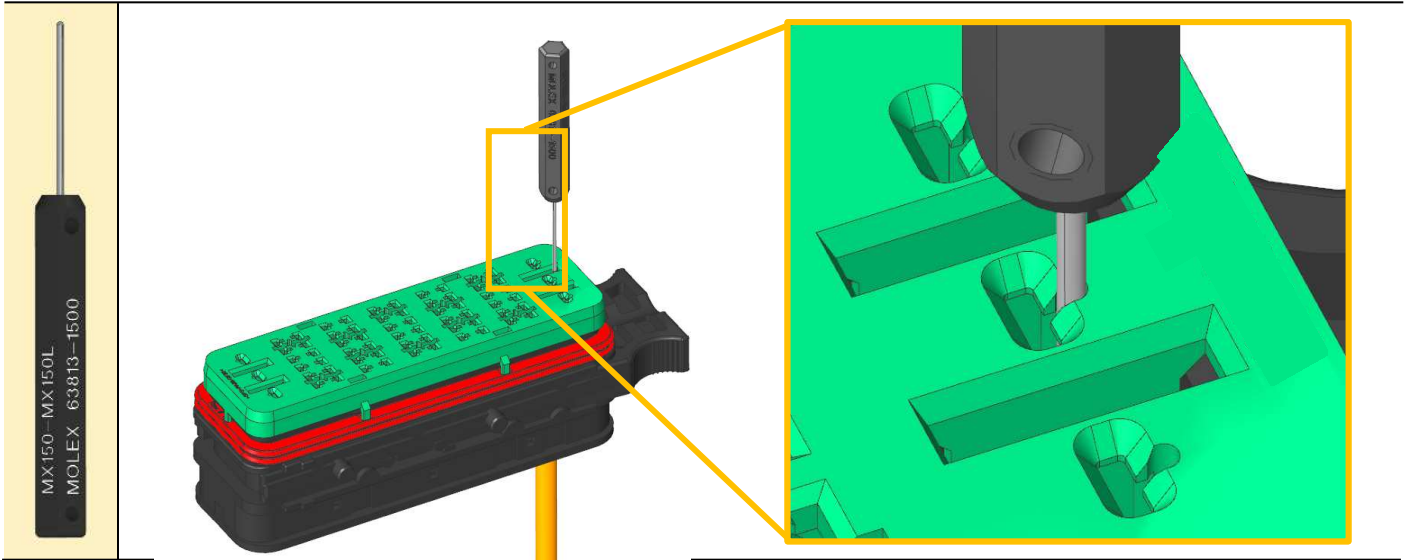

- Special case for female power cavities
- Pull cables carefully through the seal

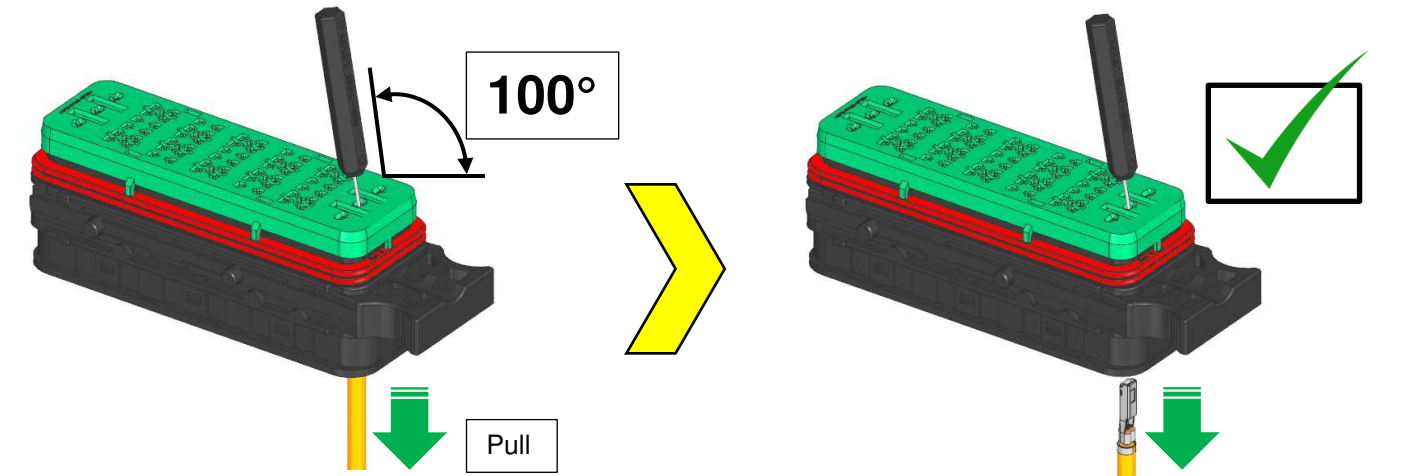
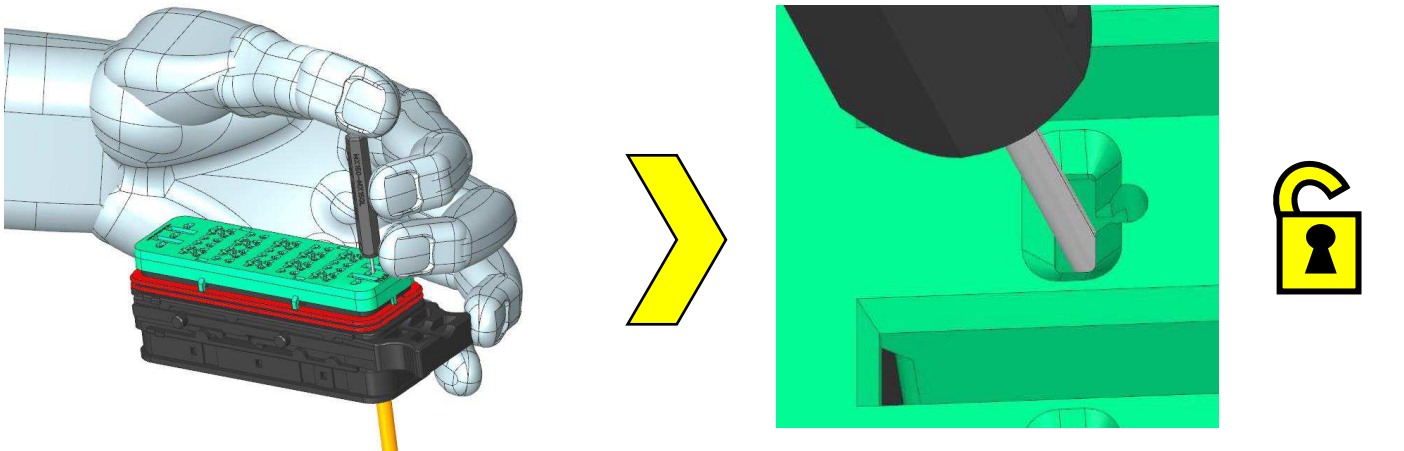

OPEN TPA – SEE SHEET 22

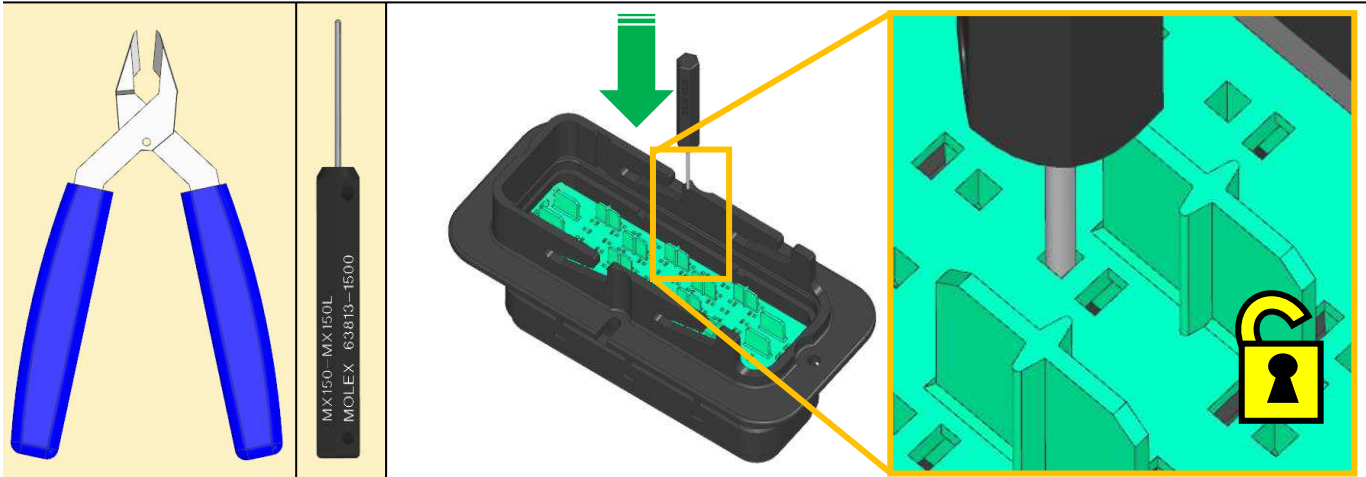

Top Tip:
A small snips helps grip short blind cavity plugs

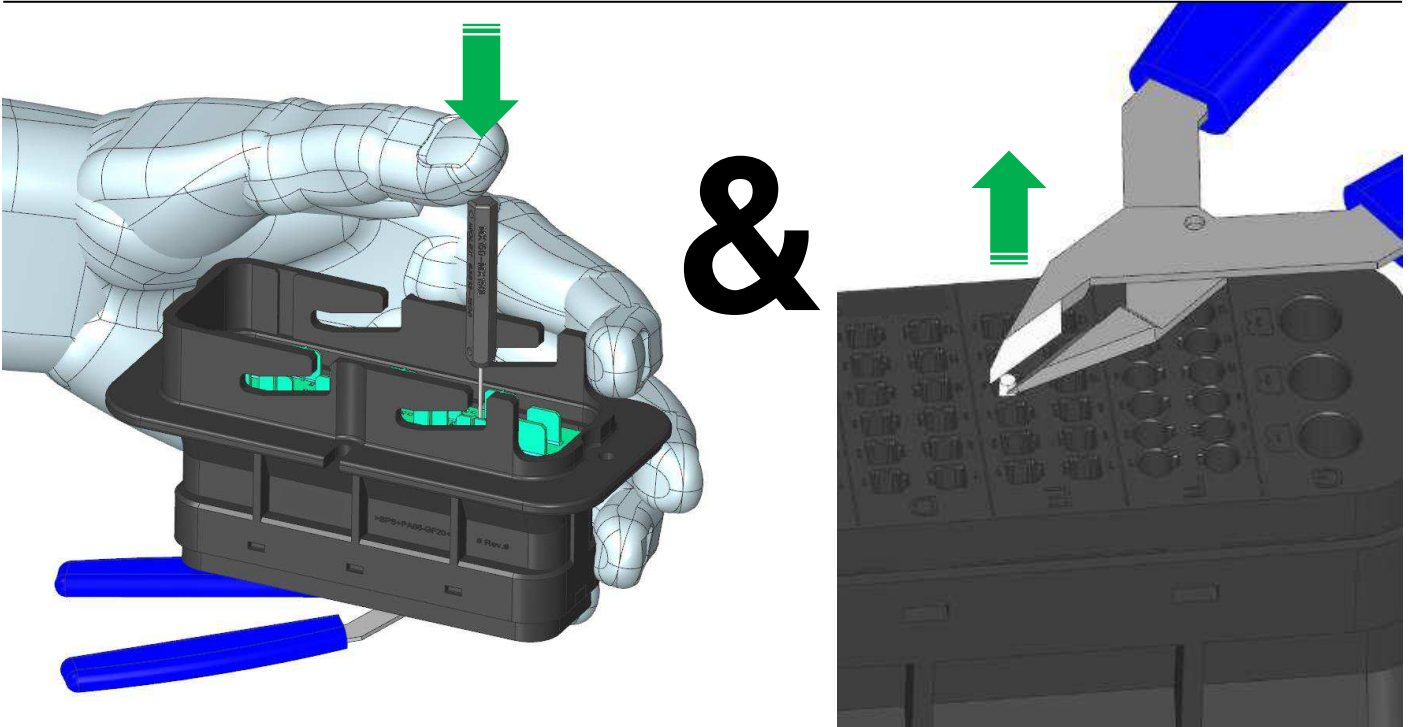

REMOVING POWER BLIND CAVITY PLUGS FROM MALE ASSEMBLY

OPEN TPA – SEE SHEET 22

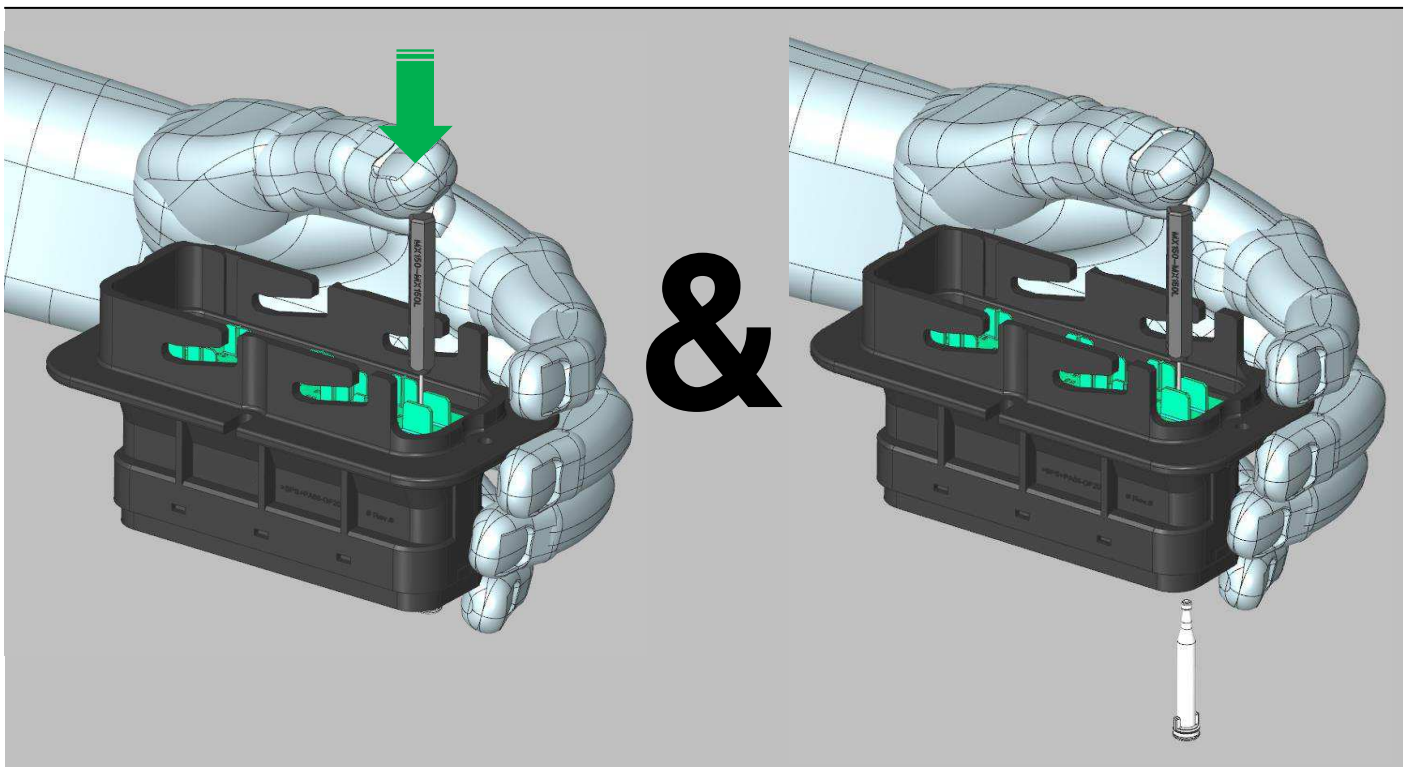
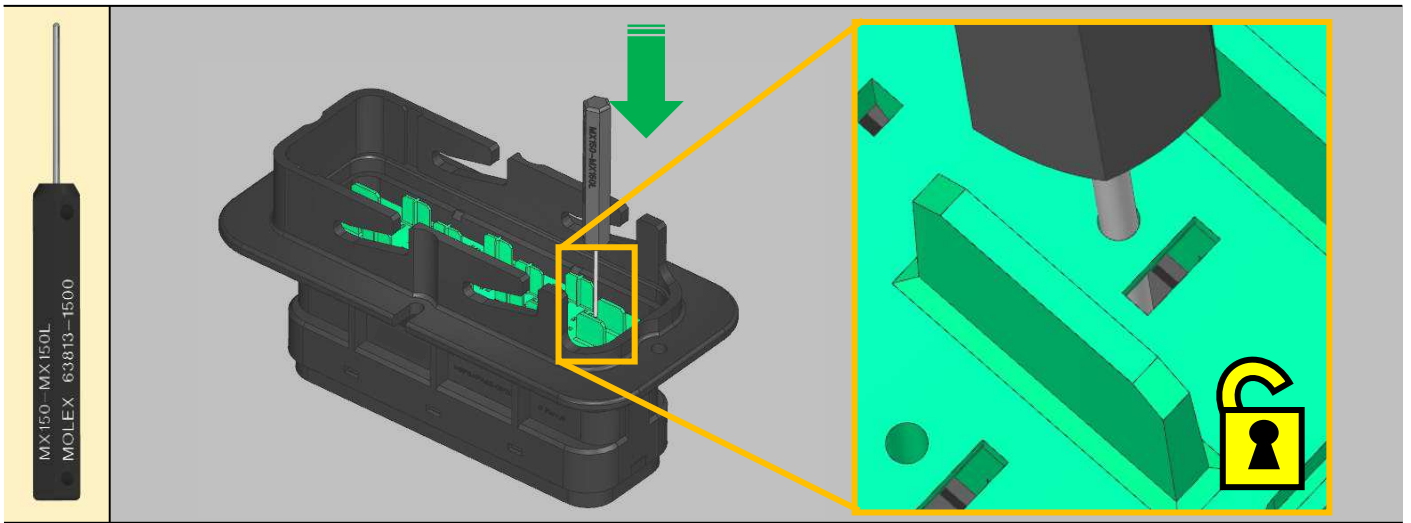

REMOVING SIGNAL & 2.5MM² TERMINALS FROM MALE ASSEMBLY

OPEN TPA – SEE SHEET 22

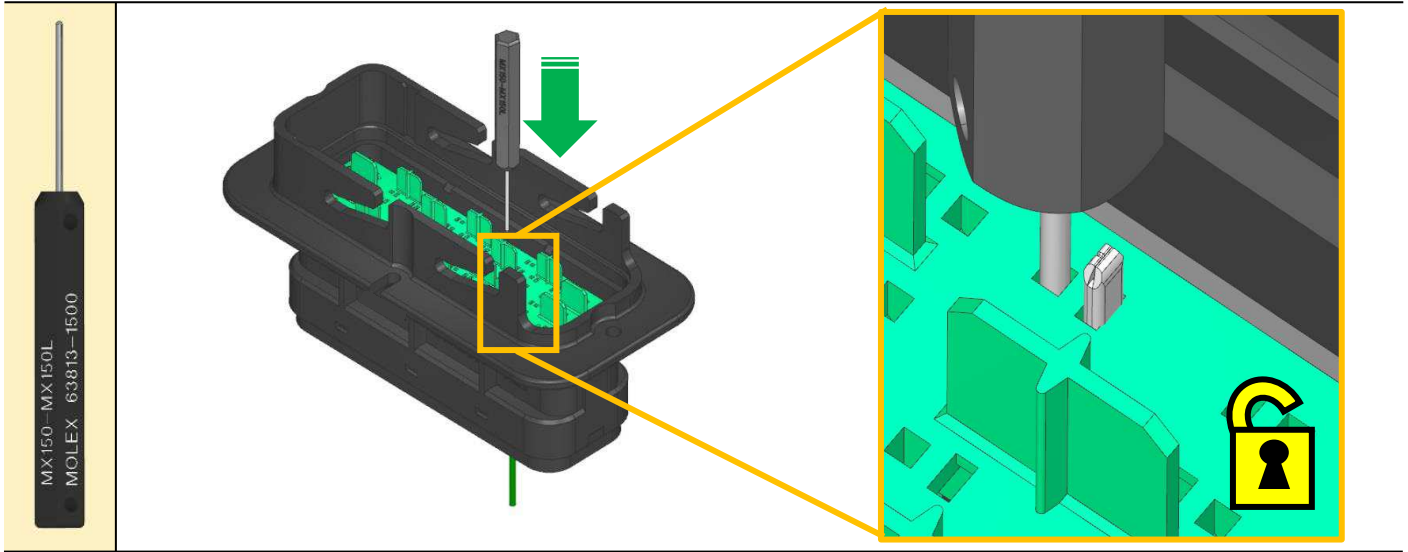

Pull cables carefully through the seal

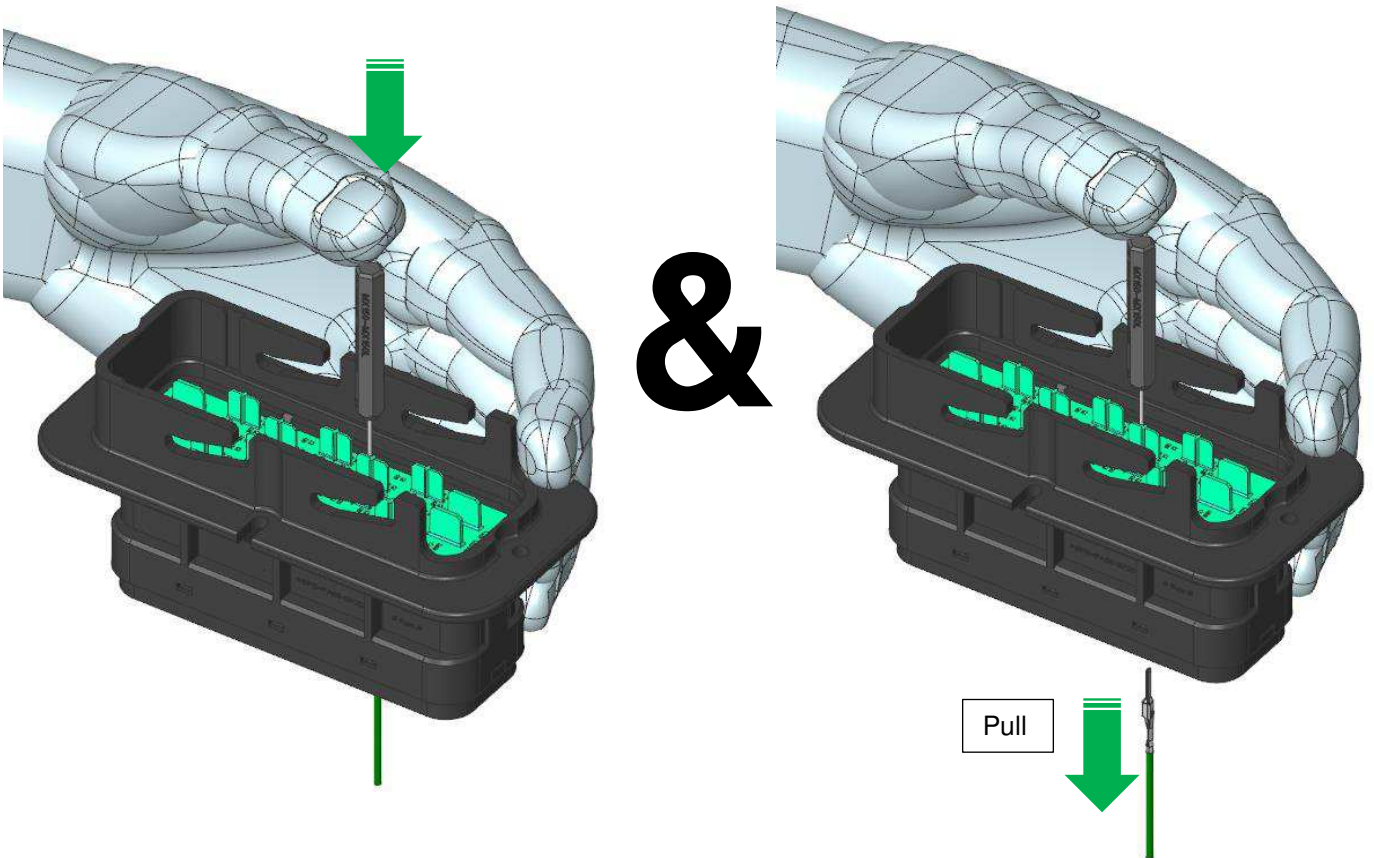

REMOVING POWER TERMINALS FROM MALE ASSEMBLY

OPEN TPA – SEE SHEET 22

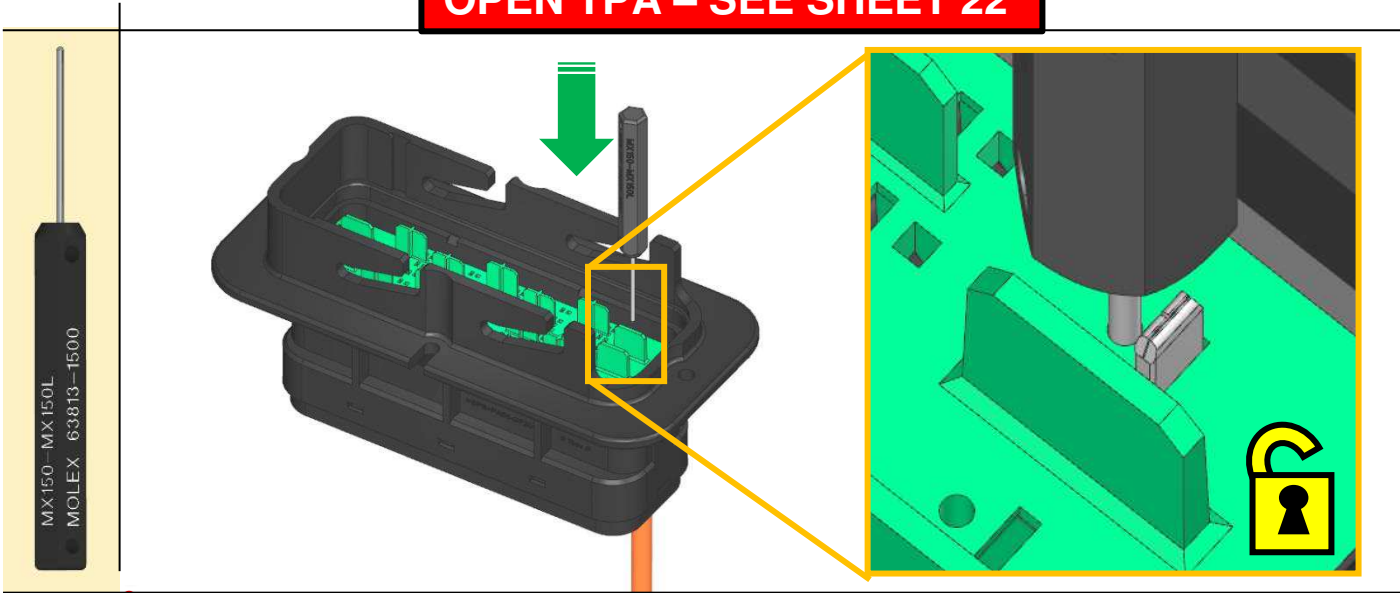

Pull cables carefully through the seal

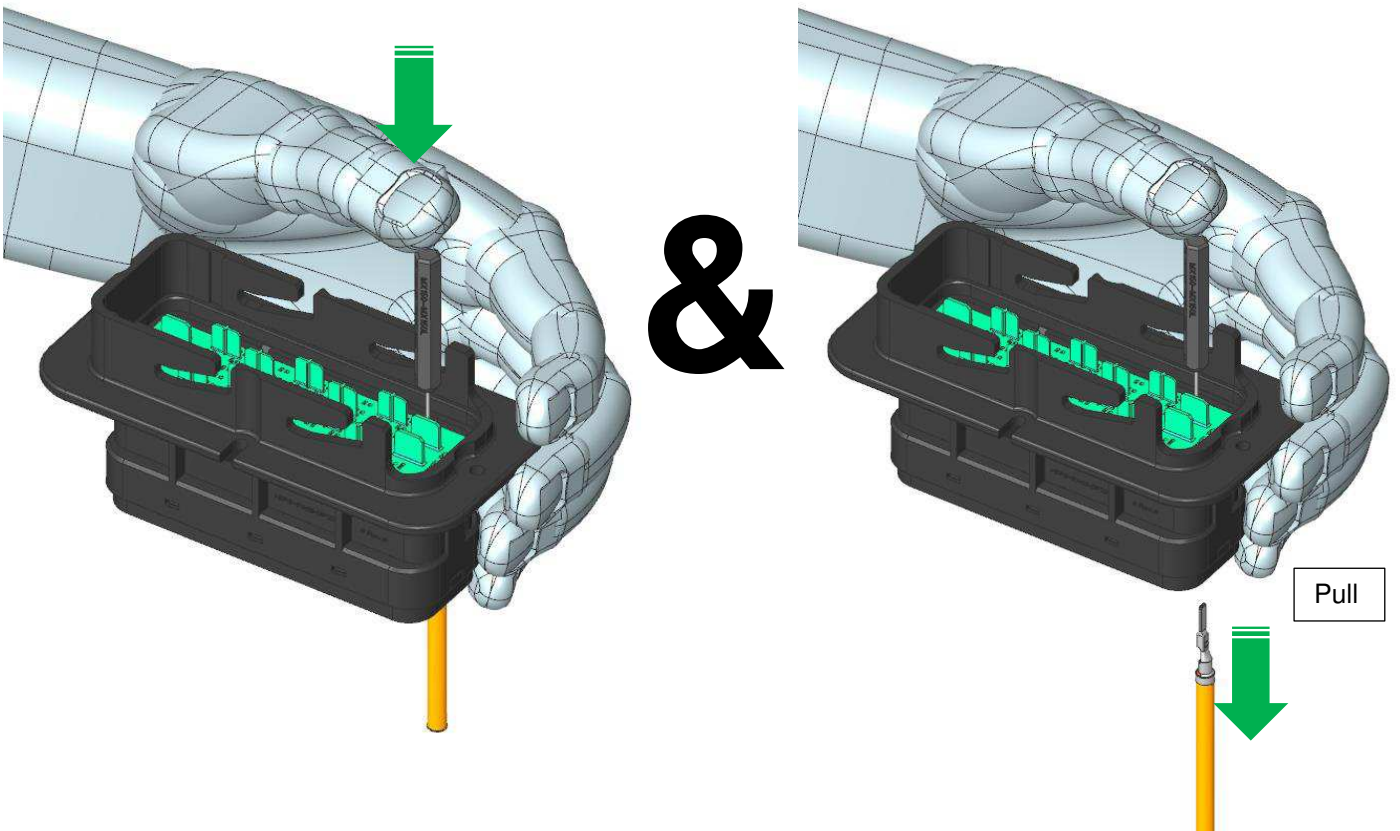

Disclaimer and Recommendations

1. Tools shown are recommendations only. TE connectivity will not be held responsible if an inappropriate tool is used for terminal removal.
2. Care must be taken when completing the 'Top Tip' sections. Terminal extraction tool must never be inserted into female terminals. Top Tip (page 9) is only ever to be used on signal blind cavity plugs to push them out in the event of over-insertion.
3. Take care when removing blind cavity plugs using a snips as they are easy to cut, the snips is only used to help grip the plugs.
4. TE connectivity recommends trimming the signal blind cavity plugs after insertion. This should always be completed before any wires are assembled into the connector housings.
5. Take care when removing blind cavity plugs from a fully assembled connector, do not damage the neighbouring cables with the snips.
6. Always insert the male terminal at 90° to the rear cover. Insert with care through the seal.
7. When inserting terminals hold the cable approx. 1cm back from the insulation crimp.
8. Conduit must be used in conjunction with the conduit interface/wire dress. Molex will not be held responsible if cables get damaged when conduit is not used with the conduit interface/wire dress. Each cable bundle should occupy a maximum of 70% of each conduit exit.
9. **This instruction manual shows a 60+6 configuration for demonstration purposes only. Always ensure the appropriate harness wiring diagram is followed.**
10. Power blind cavity plugs must be pulled fully back in the female housing before the TPA is closed.
11. Terminal and blind cavity plug removal – parts must be pulled out of assembly in the direction shown by the green arrow in the pictures.
12. Before mating connectors please ensure both connectors are fully populated and that the final checks have been completed.

Reference documents

| | |
|----------------------|---|
| 2500000 thru 2500015 | SRC Female Receptacle Housing Assembly Sales Drawing |
| 2500016 thru 2500031 | SRC Male Housing Assembly Sales Drawing (Extended Rear Cover) |
| 2500034 | SRC Female Conduit Interface Sales Drawing |
| 2500035 | SRC Male Conduit Interface Sales Drawing |
| TEC-108-160018 | SRC Male and Female Mixed Power Assembly Product Specification |
| 107-160003-02 | SRC Male Assembly Packaging Specification (Extended Rear Cover) |
| 107-160003-01 | SRC Female Receptacle Housing Packaging Specification |
| 107-160003-04 | SRC Conduit interface Packaging Specification |
| TEC-108-160019 | SRC Conduit interface Product Specification |
| 2500033 | SRC Power Blind Cavity Plug Sales Drawing |
| 107-160003-05 | SRC Power Blind Cavity Plug Packaging Specification |
| TEC-108-160020 | SRC Power Blind Cavity Plug Product Specification |

The following documents are Molex documents related to terminals used in the SRC Connectors

| | |
|---------------|--|
| SD-19431-*** | MX150L Various Male Blade Terminal Sales Drawings |
| SD-19434-*** | MX150L Various Female Receptacle Terminal Sales Drawings |
| SD-33000-001 | MX150 Male Blade Terminal Sales Drawing |
| SD-33012-002 | MX150 Female Receptacle Terminal Sales Drawing |
| 936420010 PSD | SRC 2.5mm ² Blade Terminal Sales Drawing |
| 936420010 PSK | SRC 2.5mm ² Blade Terminal Packaging Specification |
| 936430010 PSD | SRC 2.5mm ² Receptacle Terminal Sales Drawing |
| 936430010 PSK | SRC 2.5mm ² Receptacle Terminal Packaging Specification |
| 936420010 PSP | SRC 2.5mm ² Terminal Product Specification |

Thanks for choosing TE Connectivity

