

LOC	DIST	REVISIONS				
P	LTR REV	DESCRIPTION MODIFICATIONS	DATE	DWN DESS.	APVD APP.	
FH	2					
	I	CREATION	22MAR2007	FB	AG	
	A	TORQUE UPDATE	08SEP2008	XG	AG	

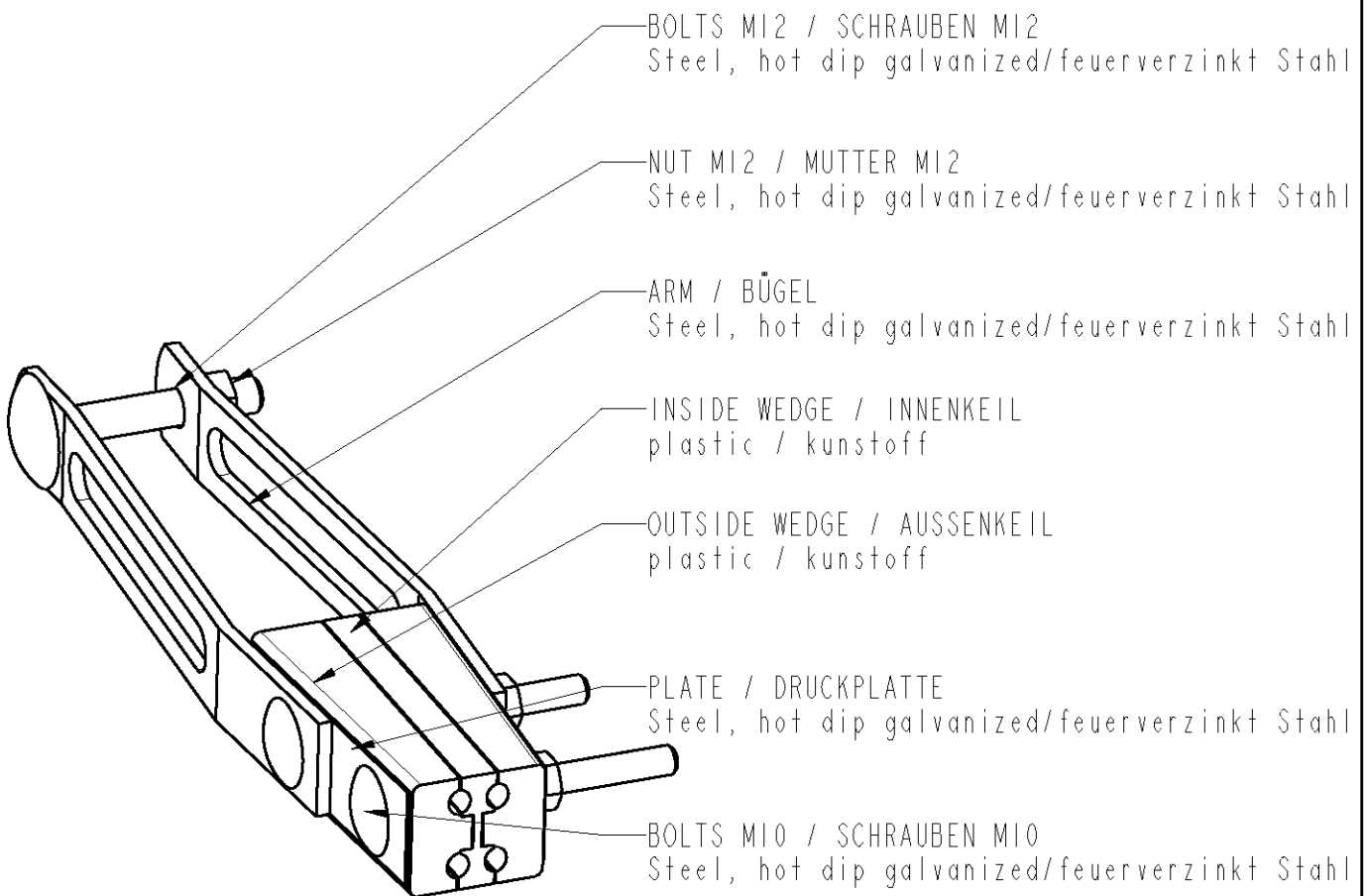
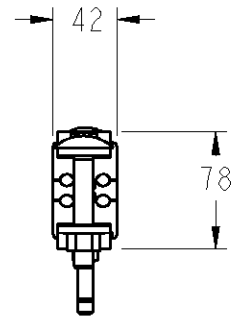
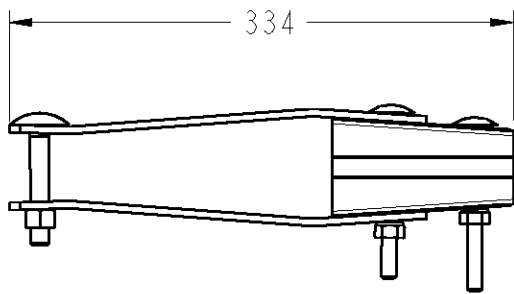

Capacity / Klemmbereich : 4x25-50 mm²
 Tightening torque / Anzugsmoment : 45 N.m

TOLERANCES UNLESS OTHERWISE SPECIFIED	-
TOLERANCES NON SPECIFIÉES	-
FINISH	-
FINITION	-

DIMENSIONS:	mm
TOLERANCES UNLESS OTHERWISE SPECIFIED, TOLERANCES NON SPECIFIÉES (SUIV. NB DE DECIMALES):	
0	PLC / DEC: ±0
1	PLC / DEC: ±0
2	PLC / DEC: ±0
3	PLC / DEC: ±0
4	PLC / DEC: ±0
ANGLES ±	

DWN / DESSINE F. BOARD	22MAR2007
CHK / VERIFIE G. NEDELLEC	-
APVD / APPROUVE A. GUICHARD	-
PRODUCT SPEC SPEC. PRODUIT	-
APPLICATION SPEC SPEC. APPLICATION	-
WEIGHT MASSE APPROX.	1415 g

MATERIAL MATIERE	-	FINISH FINITION	-
		SIMEL PRODUCTS	
NAME TITRE		HEL-5503	
SIZE FORMAT	CAGE CODE	DRAWING NO No PLAN	RESTRICTED TO RESERVE A
A4	-	C=1-1199008-4	-

CUSTOMER DRAWING / PLAN CLIENT	UNIQUEMENT POUR REFERENCE	SCALE ECHELLE : 5	SHEET FEUILLE OF DE	REV A
--------------------------------	---------------------------	---------------------	-----------------------	-------

RELEASED FOR PUBLICATION / LIBRE A LA DIFFUSION
 THIS DRAWING IS UNPUBLISHED. / DIFFUSION RESTREINTE
 BY TYCO ELECTRONICS CORPORATION. ALL RIGHTS RESERVED. / TOUS DROITS RESERVES.