Heavy Range Siameze Insulation Displacement Terminals

DESIGN OBJECTIVES

The product described in this document has not been fully tested to ensure conformance to the requirements outlined below. Therefore Tyco Electronics makes no representation or warranty, express or implied, that the product will comply with these requirements. Further, Tyco Electronics may change these requirements based on the results of additional testing and evaluation. Contact Tyco Electronics Engineering for further details.

1. SCOPE

1.1. Content

This specification covers performance, tests and quality requirements for the Tyco Electronics Heavy Range Siameze Insulation Displacement Terminals designed for general use as a magnet wire to external interface when inserted into a plastic pocket (cavity) designed to Tyco Electronics guidelines. The terminal is compatible with Single and Double build copper magnet wire 12 through 20 AWG (2.05 through 0.81 mm) unless otherwise specified on the Tyco Electronics Customer drawing.

1.2. Qualification

When tests are performed on the subject product line, procedures specified in Figure 1 shall be used. All inspections shall be performed using the applicable inspection plan and product drawing.

2. APPLICABLE DOCUMENTS

The following documents form a part of this specification to the extent specified herein. Unless otherwise specified, the latest edition of the document applies. In the event of conflict between the requirements of this specification and the product drawing, the product drawing shall take precedence. In the event of conflict between the requirements of this specification and the referenced documents, this specification shall take precedence.

2.1. Tyco Electronics Documents

- 109-197: Test Specification (AMP Test Specifications vs EIA and IEC Test Methods)
- 114-(TBD): Application Specification (TBD)
- 501-(TBD): Qualification Test Report (Heavy Range Siameze Insulation Displacement Terminals)

2.2. Industry Standard

EIA-364: Electrical Connector/Socket Test Procedures Including Environmental Classifications

3. REQUIREMENTS

3.1. Design and Construction

Product shall be of the design, construction and physical dimensions specified on the applicable product drawing.

3.2. Materials

Materials used in the construction of this product shall be as specified on the applicable product drawing.

3.3. Performance and Test Description

Product is designed to meet the electrical, mechanical and environmental performance requirements specified in Figure 1. Unless otherwise specified, all tests shall be performed at ambient environmental conditions per EIA-364. All electrical and environmental tests shall be performed with the terminals inserted into a Tyco Electronics bobbin with a connection configuration per Figure 4.

3.4. Test Requirements and Procedures Summary

Test Description	Requirement	Procedure
Initial examination of product.	Meets requirements of product drawing.	EIA-364-18. Visual and dimensional (C of C) inspection per product drawing.
Final examination of product.	Meets visual requirements.	EIA-364-18. Visual inspection.
ELECTRICAL		
Low level contact resistance.	See Figure 3.	EIA-364-23. Subject specimens to 100 milliamperes maximum and 20 millivolts maximum open circuit voltage.
Current cycling.	20% maximum increase from initial LLCR reading. See Figure 4.	EIA-364-55, Test Condition A, Test Method 2. Subject specimens to 100% of rated current for wire size being tested for 500 cycles of 15 minutes ON and 15 minutes OFF.
MECHANICAL		
Retention force.	90 N [20 lbf] minimum. See Note 1.	EIA-364-8. Determine retention force at a maximum rate of 25.4 mm [1 in] per minute.
ENVIRONMENTAL		
Thermal shock.	See Note 2.	EIA-364-32. Subject specimens to 25 cycles between -65 and 125°C.
Humidity-temperature cycling.	See Note 2.	EIA-364-31, Method III. Subject specimens to 10 cycles (10 days) between 25 and 65°C at 80 to 100% RH.
Temperature life.	20% maximum increase from initial LLCR reading. See Note 2.	EIA-364-17. Subject specimens to 118°C for 33 days.

NOTE

- (1) Force required to extract the terminal from a pocket (cavity) molded to Tyco Electronics guidelines in Nylon 6/6 30% GF.
- (2) Shall meet visual requirements, show no physical damage, and meet the requirements of additional tests as specified in the Product Qualification and Requalification Test Sequence shown in Figure 2.

Figure 1

3.5. Product Qualification and Requalification Test Sequence

Test or Examination	Test Group (a)			
	1	2	3	4
	Test Sequence (b)			
Initial examination of product	1	1	1	1
Low level contact resistance	2,5		2,4	2,4
Current cycling		2		
Retention force			3	
Thermal shock	4			
Humidity-temperature cycling	3			
Temperature life				3
Final examination of product	6	3	5	5

NOTE

- (a) See paragraph 4.1.A.
- (b) Numbers indicate sequence in which tests are performed.

Figure 2

4. QUALITY ASSURANCE PROVISIONS

4.1. Qualification Testing

A. Specimen Selection

Specimens shall be prepared in accordance with applicable Instruction Sheets and shall be selected at random from current production. Each test group shall consist of 30 terminals (15 interconnected bobbin assemblies) with the smallest and largest wire size.

B. Test Sequence

Qualification inspection shall be verified by testing specimens as specified in Figure 2.

4.2. Requalification Testing

If changes significantly affecting form, fit or function are made to the product or manufacturing process, product assurance shall coordinate requalification testing, consisting of all or part of the original testing sequence as determined by development/product, quality and reliability engineering.

4.3. Acceptance

Acceptance is based on verification that the product meets the requirements of Figure 1. Failures attributed to equipment, test setup or operator deficiencies shall not disqualify the product. If product failure occurs, corrective action shall be taken and specimens resubmitted for qualification. Testing to confirm corrective action is required before resubmittal.

4.4. Quality Conformance Inspection

The applicable quality inspection plan shall specify the sampling acceptable quality level to be used. Dimensional and functional requirements shall be in accordance with the applicable product drawing and this specification.

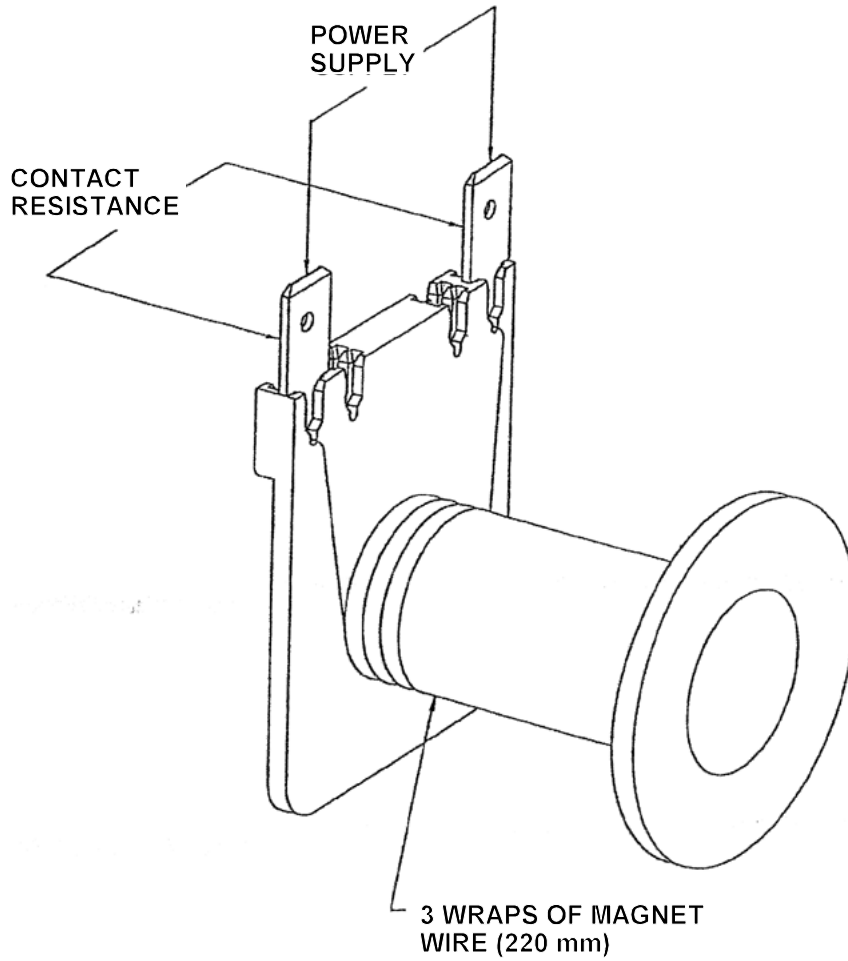

Figure 3
Test Configuration

Wire Size (AWG [mm ø])	Current Carrying Capacity (amperes)
12 (2.05)	26
13 (1.83)	26
14 (1.63)	24
15 (1.45)	21
16 (1.29)	18

Wire Size (AWG [mm ø])	Current Carrying Capacity (amperes)
17 (1.15)	16
18 (1.02)	13
19 (0.91)	11
20 (0.81)	10

Figure 4